

THIS DRAWING IS UNPUBLISHED. RELEASED FOR PUBLICATION
 © COPYRIGHT 2005 By - ALL RIGHTS RESERVED.

LOC	DIST	REVISIONS					
GP	00	P	LTR	DESCRIPTION	DATE	DWN	APVD
		B		REVISED PER ECO-14-011808	11AUG2014	AP	SB

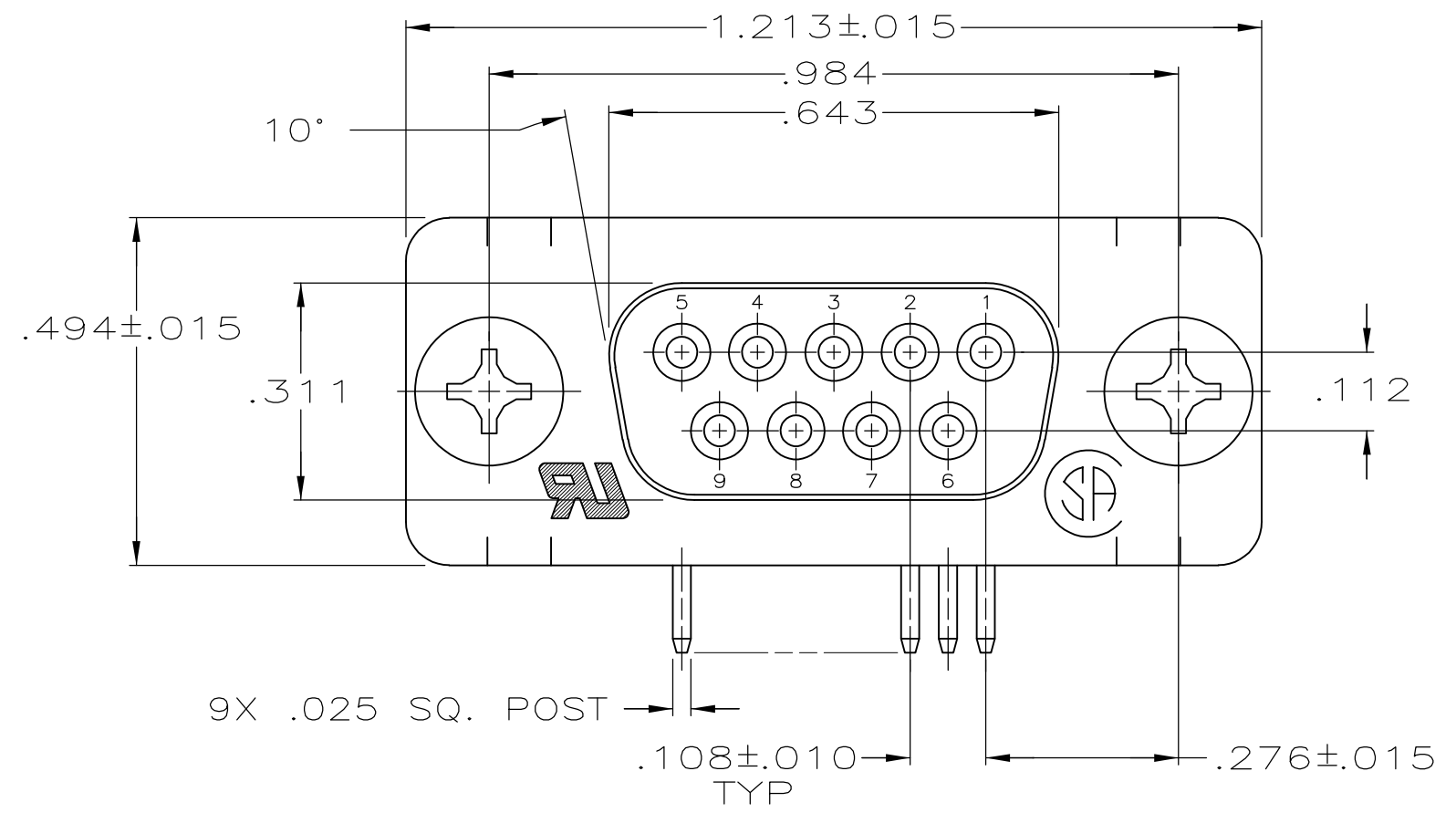

- 1 MOLDED PARTS: GLASS-FILLED PBT OR GLASS-FILLED NYLON, UL94V-0 RATED. COLOR BLACK.
SHELLS & BRACKETS: CARBON STEEL
CONTACTS: PHOS BRONZE
- 2 SHELLS: .000200 MIN TIN OVER .000100 MIN COPPER.
BRACKETS: .000200 MIN TIN OVER .000050 MIN COPPER.
CONTACTS: .000030 MINIMUM GOLD FOR A LENGTH OF .100 MINIMUM FROM MATING END, .000100 MINIMUM TIN ON OPPOSITE END, BOTH OVER .000050 MINIMUM NICKEL
-OR-
GOLD FLASH OVER .000030 MINIMUM PALLADIUM NICKEL PLATED FOR LENGTH OF .100 MINIMUM FROM MATING END, .000100 MINIMUM TIN ON OPPOSITE END, BOTH OVER .000050 MINIMUM NICKEL.

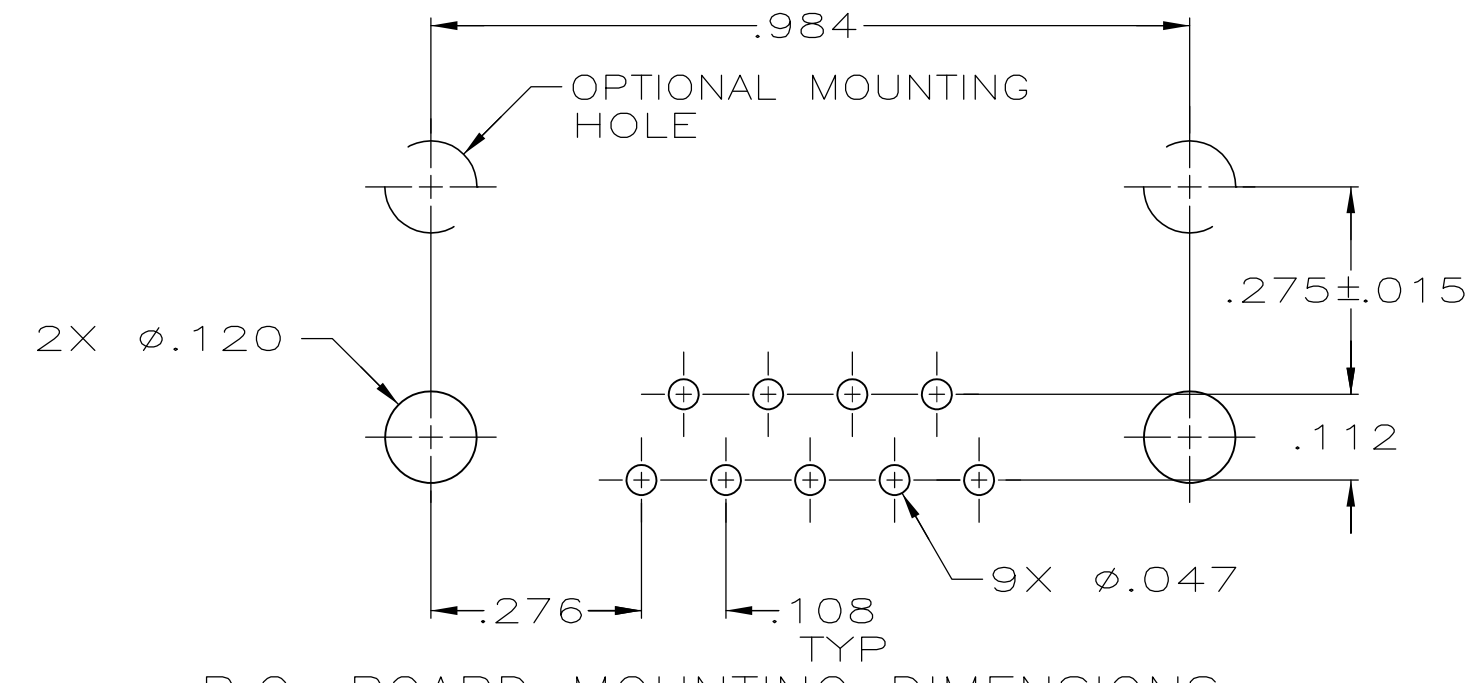
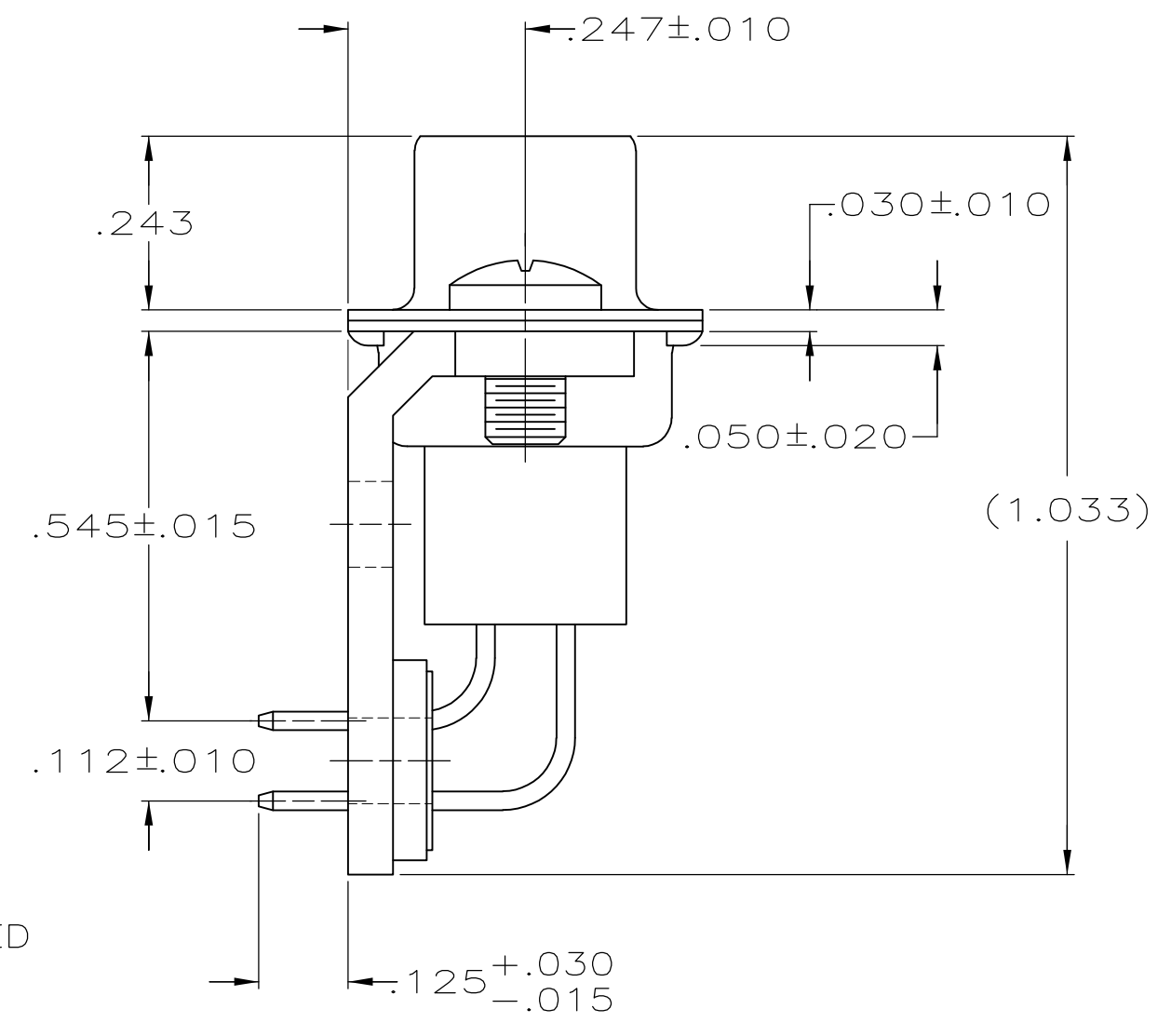
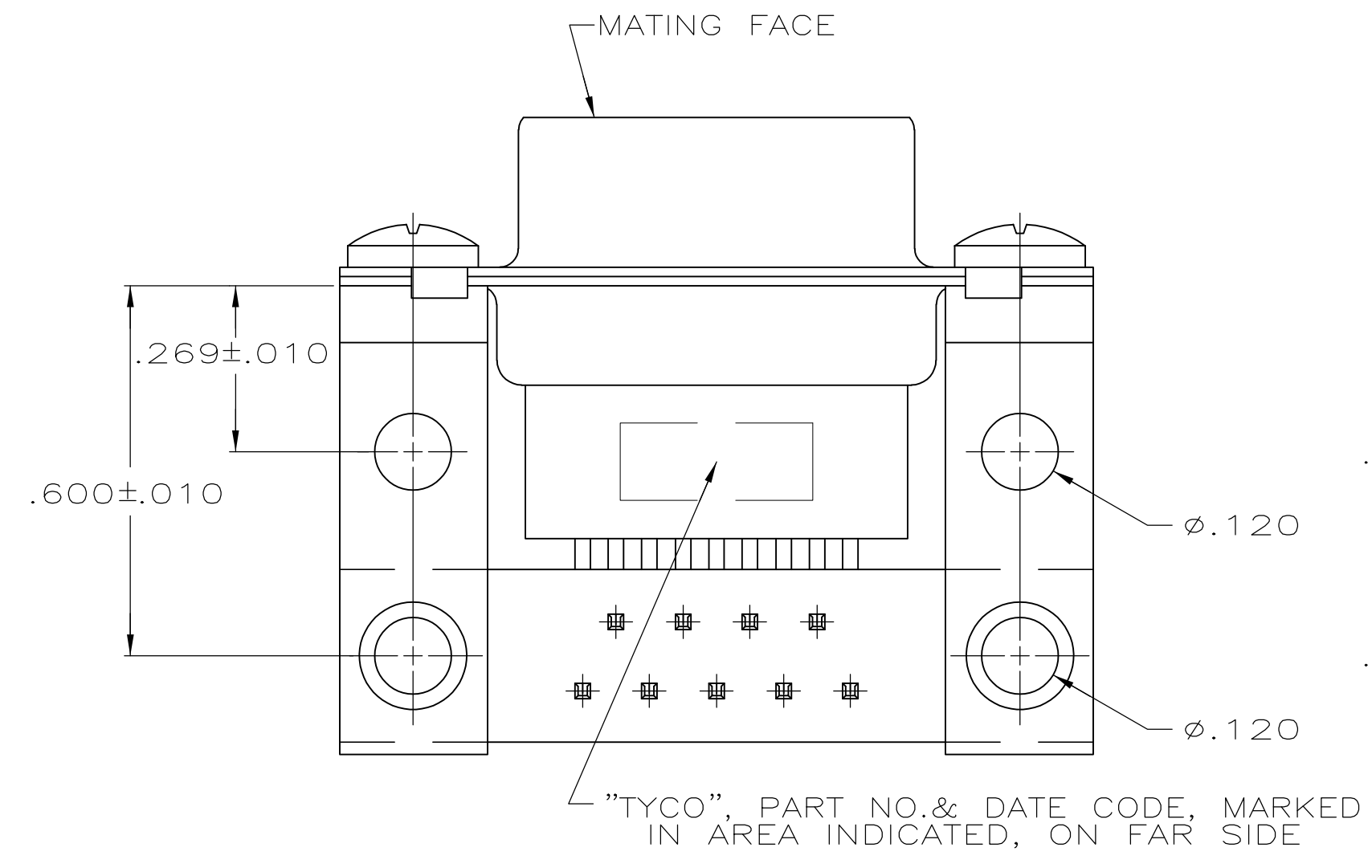

5745112

5745112-2
PART NUMBER

THIS DRAWING IS A CONTROLLED DOCUMENT.		DWN D. HENNY 8-21-05		RECEPTACLE ASSEMBLY, SIZE 1, 9 POSITION., RIGHT ANGLE, .545 SERIES, .025 SQ. POSTS, AMPLIMITE HDP		
DIMENSIONS: INCHES		CHK S. BOLASH 8-21-05		NAME	SIZE	RESTRICTED TO
TOLERANCES UNLESS OTHERWISE SPECIFIED:		APVD M. WALMSLEY 8-21-05		PRODUCT SPEC	CAGE CODE	DRAWING NO
0 PLC ± - 1 PLC ± - 2 PLC ± - 3 PLC ± .005 4 PLC ± - ANGLES ± 2° FINISH		APPLICATION SPEC		108-40025	00779	5745112
MATERIAL		WEIGHT	CUSTOMER DRAWING		SCALE 4:1	
1		2		SHEET 1 of 1		

P.C. BOARD MOUNTING DIMENSIONS