

REVISIONS			
REV.	DESCRIPTION	DATE	APPROVED
A	INITIAL RELEASE	10/08/08	M.J.

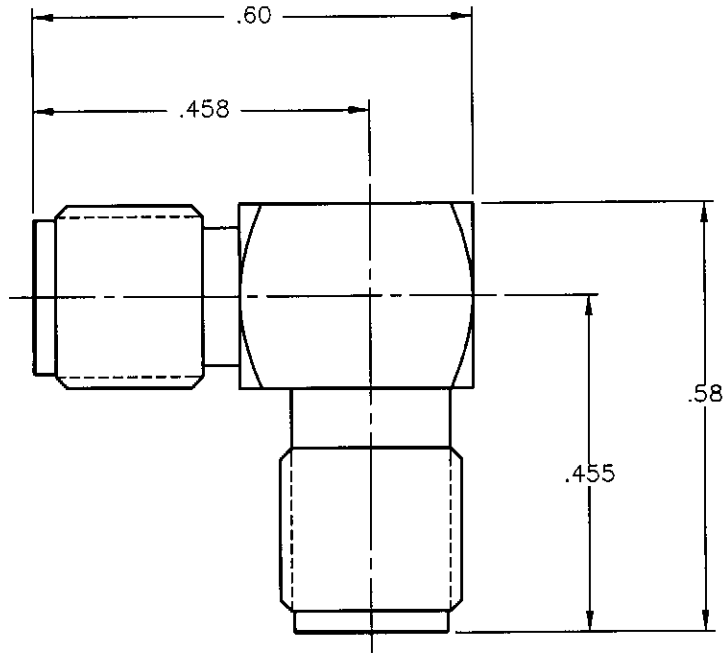

NOTES:

MATERIALS:

1. BODIES = STAINLESS STEEL PER ASTM A582, ALLOY 303, CONDITION "A".
2. CONTACTS = BERYLLIUM COPPER PER ASTM B196, ALLOY C17300, TEMPER TD04.
3. INSULATORS = VIRGIN WHITE TEFLON PER ASTM D1710, GRADE 1, TYPE I, CLASS "B".
4. CAP = BRASS PER ASTM B16, ALLOY C36000, TEMPER H02.

FINISHES:

1. BODIES = GOLD PLATE PER MIL-G-45204, TYPE II, CLASS 0, GRADE C, OVER .000050 TO .00010 STRESS FREE NICKEL PER QQ-N-290.
2. CONTACTS = GOLD PLATE PER MIL-G-45204, TYPE II, CLASS 1, GRADE C, OVER .00010 TO .00020 STRESS FREE SULFAMATE NICKEL PER QQ-N-290.
3. CAP = GOLD PLATE PER MIL-G-45204, TYPE II, CLASS 0, GRADE C, OVER .00010 TO .00020 COPPER STRIKE PER MIL-C-14550.

Property of Radiall Incorporated
 This document cannot be reproduced or
 communicated to a third party without prior
 written permission of RADIALL Incorporated.

UNLESS OTHERWISE SPECIFIED
 DIMENSIONS ARE IN INCHES
 TOLERANCES ON

DWN:	M.J.	DATE	10/08/08
CHKD:	D.N.	DATE	10/08/08
APVD:	J.M.	DATE	10/08/08

AEP APPLIED ENGINEERING PRODUCTS
 a RADIALL company
 104 John W. Murphy Dr.
 New Haven, CT 06513

DECIMAL	ANGLE

SMA RIGHT ANGLE JACK TO JACK
 ADAPTER

REFERENCE:
 ORIGINATED: M.J.
 DATE: 10/08/08

MATERIALS & FINISHES:
 SEE NOTES

SIZE	FSCM NO.	DWG NO.	REV
A	19505	5919-1503-003	A
SCALE 4:1		THIRD ANGLE PROJECTION	SHEET 1 OF 1

5919-1503-003