

REVISIONS			
NO.	DESCRIPTION	DATE	BY
11	REVISED PER ECR-20-00040	02/03/2020	DA/SW

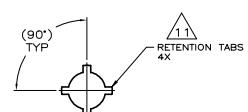
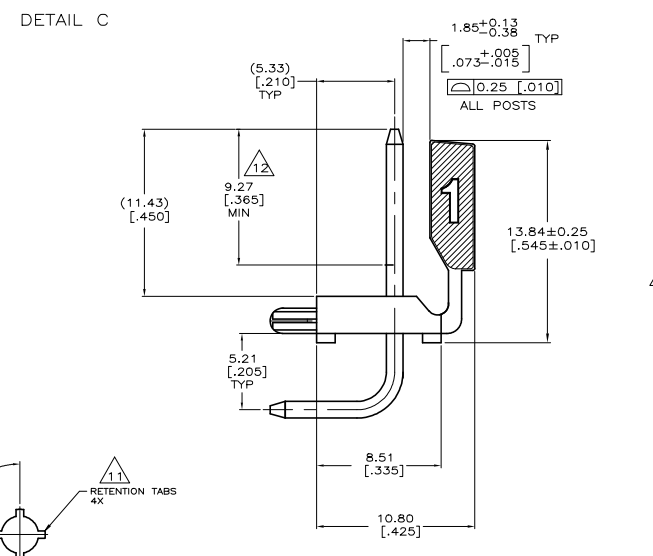
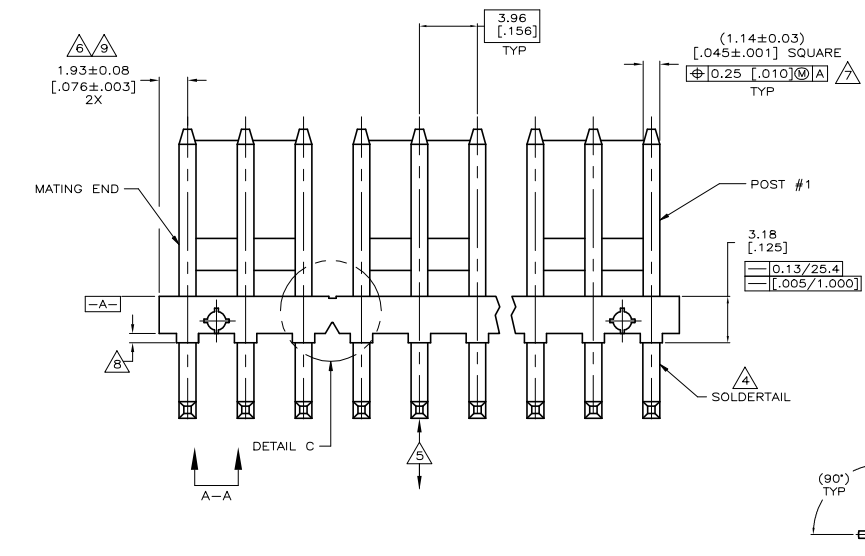
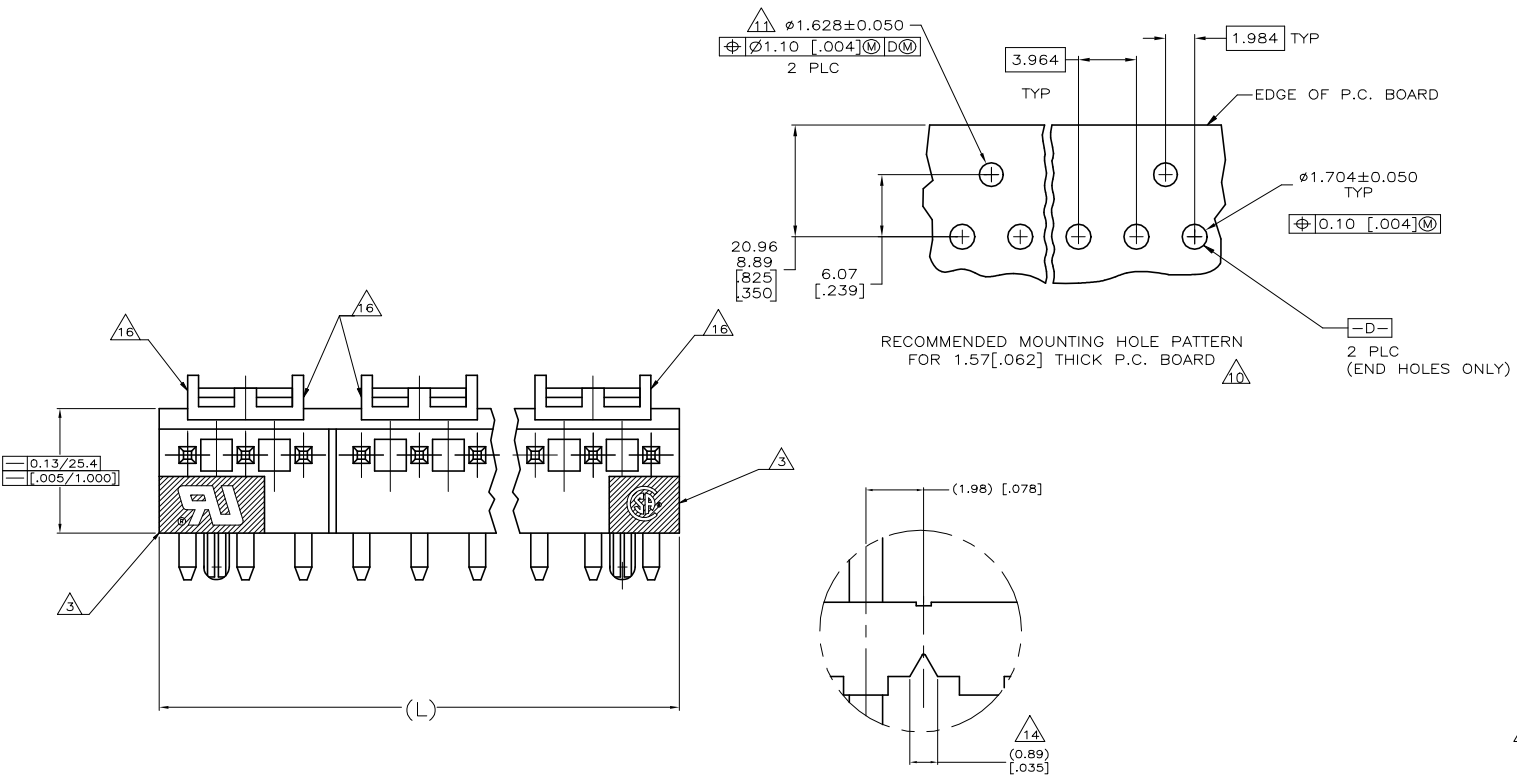

VIEW A-A  
SCALE 16:1

- 1 MATERIAL HOUSING: THERMOPLASTIC POLYESTER, GLASS FILLED, UL94V-0 POST: COPPER ALLOY
- 2 FINISH HOUSING: NATURAL POST: SEE NOTES 12, 13, & 17 FOR PLATING.
- 3 UL MARKING MAY NOT APPEAR ON THE 2 OR 3 POSITION SIZES. CSA MARKING MAY NOT APPEAR ON THE 2 POSITION SIZE.
- 4 POST SOLDERDETAILS COMPLY WITH TYCO SOLDERABILITY SPECIFICATION 109-11-2.
- 5 POST WITHSTANDS 13.34 NEWTONS (3 LBS) MINIMUM AXIAL FORCE IN EITHER DIRECTION WITHOUT DISLODGING.
- 6 APPLIES AT -A-
- 7 APPLIES WHEN THE HEADER IS STRAIGHT.
- 8 PLASTIC PROJECTIONS PERMITTED IN THIS ZONE.
- 9 COORDINATE DIMENSIONS APPLIES FROM CENTER OF THE ACTUAL FEATURE.
- 10 SOLDER SIDE OF BOARD IS SHOWN.
- 11 THE RETENTION TABS PROVIDE A ONE-TIME INTERFERENCE FIT IN THE 1.63 [0.064] DIAMETER BOARD HOLES FOR HEADER ASSEMBLY RETENTION DURING SOLDERING. FOUR TABS PER PEG, TWO PEGS PER HEADER ASSEMBLY (ONE PEG ONLY FOR 2 POSITION SIZE).
- 12 PLATING: GOLD PLATE AREA, 0.00076 [0.000030] GOLD OR 0.00008 [0.000003] MIN GOLD FLASH OVER 0.00068 [0.000027] PALLADIUM NICKEL, PER TE CONNECTIVITY'S DISCRETION, ALL SIDES, OVER NICKEL UNDERPLATE, 0.00127 [0.000050] MIN, ALL SIDES AND ENTIRE LENGTH OF POST.
- 13 PLATING: MATTE TIN PLATE AREA, 0.00381-0.00889 [0.000150-0.000350] THICK, ALL FOUR SIDES, OVER, 3.18 [0.125] MINIMUM.
- 14 DIMENSIONS IN BRACKETS ARE IN INCHES.
- 15 ALL POSITION SIZES HAVE THE BACK WALL NOTCHED ON BOTH ENDS AS SHOWN. THE 2 THRU 5 POSITION SIZES HAVE SOLID BACK WALLS. POSITION SIZES 6 AND ABOVE HAVE AN INTERRUPTED BACK WALLS AT VARIOUS LOCATIONS (SEE TABLE FOR INTERRUPTION(S) LOCATIONS).
- 16 EDGE OF POLARIZING LOCK WALL TO BE IN LINE WITH CENTERLINE OF ADJACENT POST WITHIN ±0.13 [0.005].
- 17 PLATING: MATTE TIN PLATE AREA, 0.00381-0.00889 [0.000150-0.000350] THICK, ALL FOUR SIDES, OVER, 3.18 [0.125] MINIMUM.

4&5	7&8	11&12	14&15	71.20	[2.803]	18	4-644633-8
4&5	7&8	10&11	13&14	67.23	[2.647]	17	4-644633-7
4&5	8&9	12&13		63.27	[2.491]	16	4-644633-6
4&5	8&9	11&12		59.31	[2.335]	15	4-644633-5
4&5	7&8	10&11		55.35	[2.179]	14	4-644633-4
4&5	7&8	10&11		51.38	[2.023]	13	4-644633-3
4&5	8&9			47.42	[1.867]	12	4-644633-2
4&5	7&8			43.46	[1.711]	11	4-644633-1
3&4	7&8			39.50	[1.555]	10	4-644633-0
3&4	6&7			35.53	[1.399]	9	4-644633-9
4&5				31.57	[1.243]	8	4-644633-8
4&5				27.61	[1.087]	7	4-644633-7
3&4				23.65	[0.931]	6	4-644633-6
	NONE			19.69	[0.775]	5	3-644633-5
	NONE			15.72	[0.619]	4	3-644633-4
	NONE			11.76	[0.463]	3	3-644633-3
	NONE			7.80	[0.307]	2	3-644633-2

4&5	7&8	11&12	14&15	71.20	[2.803]	18	1-644633-8
4&5	7&8	10&11	13&14	67.23	[2.647]	17	1-644633-7
4&5	8&9	12&13		63.27	[2.491]	16	1-644633-6
4&5	8&9	11&12		59.31	[2.335]	15	1-644633-5
4&5	7&8	10&11		55.35	[2.179]	14	1-644633-4
4&5	7&8	10&11		51.38	[2.023]	13	1-644633-3
4&5	8&9			47.42	[1.867]	12	1-644633-2
4&5	7&8			43.46	[1.711]	11	1-644633-1
3&4	7&8			39.50	[1.555]	10	1-644633-0
3&4	6&7			35.53	[1.399]	9	1-644633-9
4&5				31.57	[1.243]	8	1-644633-8
4&5				27.61	[1.087]	7	1-644633-7
3&4				23.65	[0.931]	6	1-644633-6
	NONE			19.69	[0.775]	5	1-644633-5
	NONE			15.72	[0.619]	4	1-644633-4
	NONE			11.76	[0.463]	3	1-644633-3
	NONE			7.80	[0.307]	2	1-644633-2

THIS DRAWING IS A CONTROLLED DOCUMENT. THE HOLDER IS RESPONSIBLE FOR THE PROTECTION OF THIS DOCUMENT.

TE Connectivity

108-1051

14-1020

007792-644633

DATE OF THE ISSUE: 14-1020

REVISED PER ECR-20-00040

02/03/2020

DA/SW

TE Connectivity

MTA-108 HDR ASM, PLD LOCK, FT AN FRNT ING, 345 SQ FT, 200030 AU PTDW/ RTN POS

REVISED PER ECR-20-00040

02/03/2020

DA/SW

18 OBSOLETE PARTS: OBSOLETE CIS STREAMLINING PER D.RENAUD/D.SINISI

19 OBSOLETE PART NUMBER