

RoHS Compliant

## Features

- SMD small & thin package
- Wide capacitance range
- Washable and non-washable types available
- Plus slot (+) suitable for auto-adjustment

## Applications

- AV Equipment
- Cellular Phone
- Cordless Phone
- TCXO
- Keyless Entry

## How to Order

CTZ3 S - 05 A - W 1 - P F  
① ② ③ ④ ⑤ ⑥ ⑦ ⑧

### ① Series

CTZ3	CTZ3 Series
CTZ2	CTZ2 Series

### ② Type

S	Reflow non washable type
E	Reflow washable type

### ③ Maximum Capacitance

03	3pF	30	30pF
05	5pF	40	40pF
10	10pF	50	50pF
20	20pF		

### ④ Temperature Coefficient (ppm/ °C)

A	NPO±500	C	N750±500
B	N400±500		

### ⑤ Packaging

W	W Direction Taping
X	X Direction Taping
B	Bulk

### ⑥ Taping Quantity (Unit: pcs.)

1	1,000	CTZ3 Series
2	2,000	CTZ2 Series

### ⑦ Pin Head Type

P	Plus Slot
---	-----------

### ⑧ Lead Specification

F	Lead Forming Type (CTZ3 type)
---	-------------------------------

\* ⑧ is denoted by space for CTZ2 series.

## Specifications

Part No.	Capacitance (pF)		Q 1±0.1 (MHz)	Temperature Coefficient (ppm/ °C)	
	C max.	C min.			
CTZ2 S/ E	03A	3 <sup>+100%</sup> <sub>-0%</sub>	2.0 max.	≥150	NPO±500
	05A	5 <sup>+100%</sup> <sub>-0%</sub>	3.0 max.	≥150	NPO±500
	10A	10 <sup>+100%</sup> <sub>-0%</sub>	3.0 max.	≥150	NPO±500
	20C	20 <sup>+100%</sup> <sub>-0%</sub>	5.5 max.	≥150	N750±500
CTZ3 S/ E	03A	3 <sup>+100%</sup> <sub>-0%</sub>	1.0 max.	≥300	NPO±500
	05A	5 <sup>+100%</sup> <sub>-0%</sub>	1.5 max.	≥300	NPO±500
	10A	10 <sup>+100%</sup> <sub>-0%</sub>	2.5 max.	≥300	NPO±500
	10B	10 <sup>+100%</sup> <sub>-0%</sub>	1.5 max.	≥300	N400±500
	20C	20 <sup>+100%</sup> <sub>-0%</sub>	4.5 max.	≥300	N750±500
	30C	30 <sup>+100%</sup> <sub>-0%</sub>	4.5 max.	≥300	N750±500
40C	40 <sup>+100%</sup> <sub>-0%</sub>	4.5 max.	≥300	N750±500	
50C	50 <sup>+100%</sup> <sub>-0%</sub>	4.5 max.	≥200	N750±500	

Series	Rated Voltage (V-DC)	Temperature Range (°C)	Insulation Resistance (MΩ)	Torque (g·cm)
CTZ2S/ E	25	-40 to +85	≥10 <sup>4</sup>	10 to 150
CTZ3S/ E	25	-40 to +85	≥10 <sup>4</sup>	10 to 150

Series	Dimensions (Unit: mm)	Recommended Land Pattern (Unit: mm)
CTZ2 Series		
CTZ3 Series		

## Frequency Characteristics

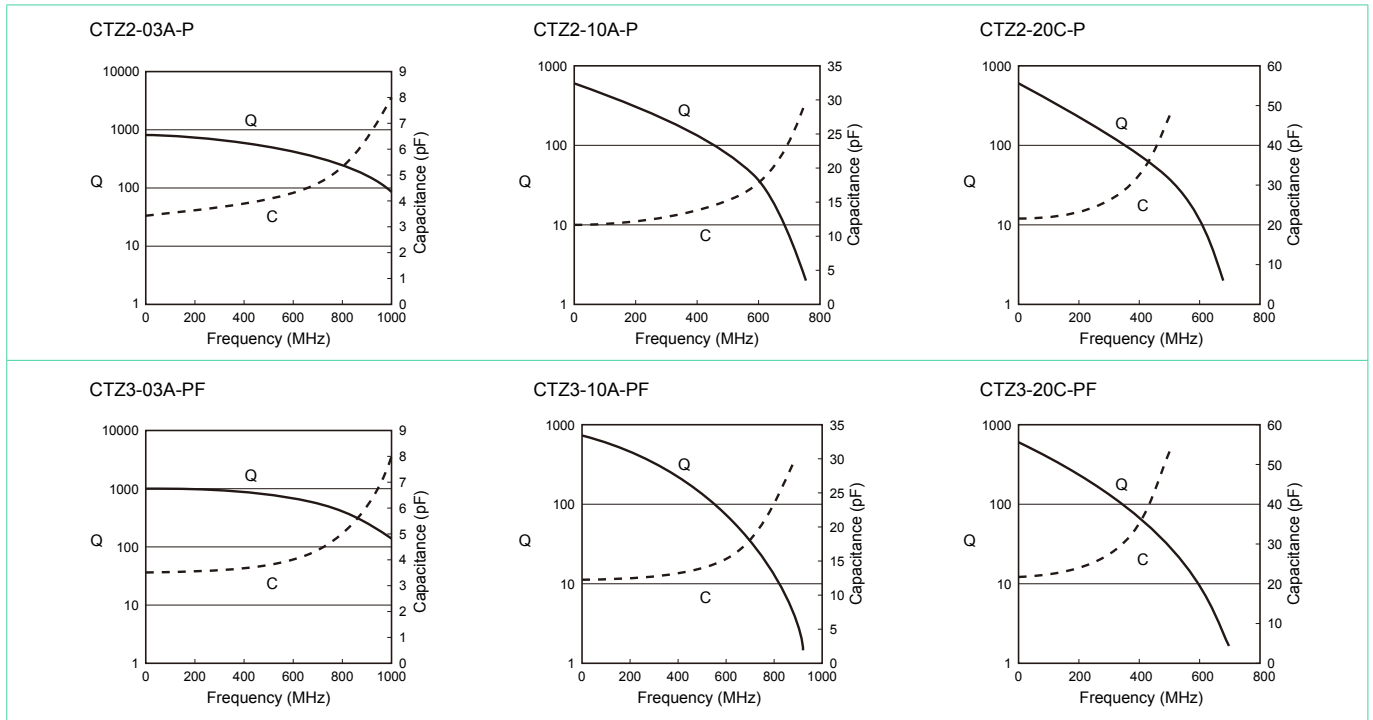

## Tape & Reel

### • Reel

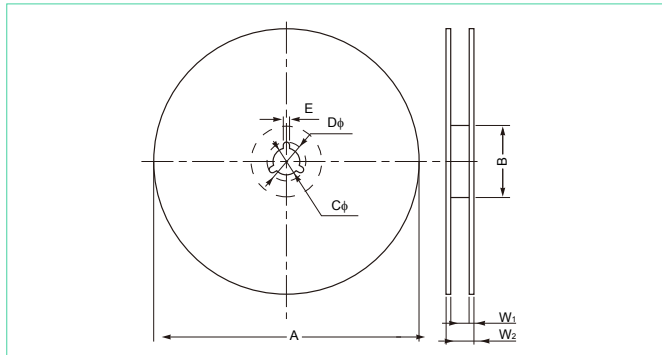

### • Carrier Tape

(Unit: mm)

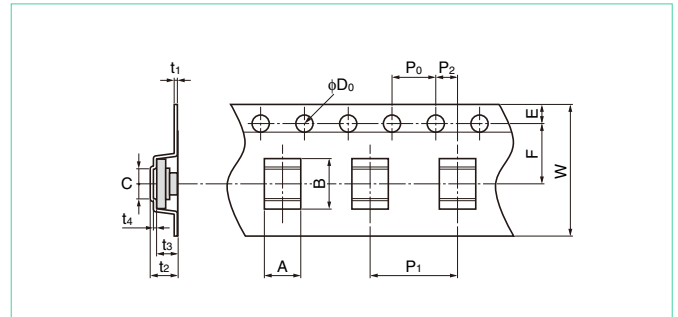

### • Tape Loading

W Direction — Standard

X Direction — Option

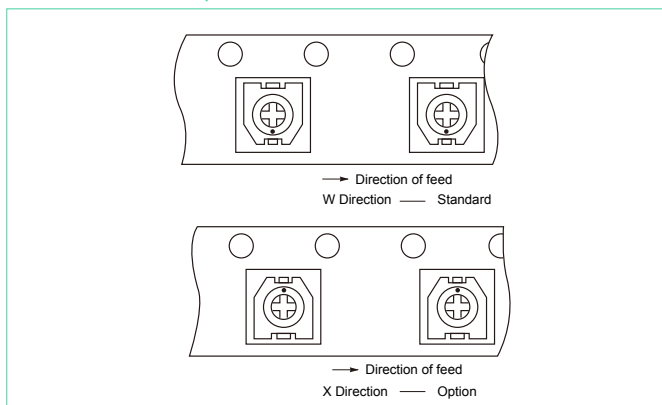

	CTZ2 Series	CTZ3 Series
A	2.7±0.1	3.35±0.1
B	3.2±0.1	4.6 <sup>+0.2</sup> <sub>-0.0</sub>
W	12.0±0.3	12.0±0.3
F	5.5±0.05	5.5±0.05
E	1.75±0.1	1.75±0.1
P <sub>0</sub>	4.0±0.1	4.0±0.1
P <sub>1</sub>	4.0±0.1	8.0±0.1
P <sub>2</sub>	2.0±0.05	2.0±0.05
φD <sub>0</sub>	1.5 <sup>+0.1</sup> <sub>-0.0</sub>	1.5 <sup>+0.1</sup> <sub>-0.0</sub>
t <sub>1</sub>	0.3±0.1	0.3±0.1
t <sub>2</sub>	1.9±0.1	2.5±0.1
t <sub>3</sub>	1.3 <sup>+0.15</sup> <sub>-0.0</sub>	2.0±0.1
t <sub>4</sub>	0.3±0.1	0.3±0.05
C	2.06±0.1	2.7±0.1

(Unit: mm)

	A	B	C	D	E	W <sub>1</sub>	W <sub>2</sub>
CTZ2 Series (2,000 pcs.)	180 <sup>+0.0</sup> <sub>-3.0</sub>	60.0 <sup>+1.0</sup> <sub>-0.0</sub>	13.0±0.2	21.0±0.8	2.0±0.5	13.0±0.3	15.4±1.0
CTZ3 Series (1,000 pcs.)							

## PCB Mounting

- When our recommended landpattern is not used, please check mounting alignment.
- When mounting on PCB, please do not apply pressure to trimmer capacitors over 500g.f.

## Soldering

- When using soldering iron, adjust iron tip to 280°C max.
- Please find below recommended solder profile.

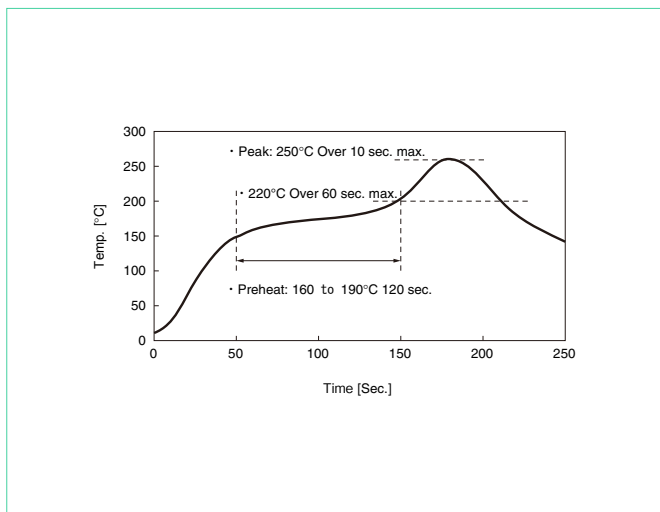

## Storage Conditions

- 1) Do not store components in corrosive condition such as chloric or sulfuric environment.
- 2) Components before use should be stored under the condition with temperature of 5 to 40 degrees Celsius and humidity of 20 to 70% RH.
- 3) It is recommended to use components within 6 months of incoming.
- 4) Do not open the minimal package until right before the use.
- 5) Do not store components under direct sunlight or dewy environment.

## Screwdrivers

Please use proper screwdriver for adjustment of the capacitor. Kyocera can supply suitable ceramic type screwdrivers specially designed for the use of CTZ series. Please contact your local AVX office for the details.

### CTZ3

Pin Head

⊕: CTZ3 Phillips-head (Plus) Ceramic Screwdriver

### CTZ2

Pin Head

⊕: CTZ2 Phillips-head (Plus) Ceramic Screwdriver

