



# MAX3946 Evaluation Kit

## General Description

The MAX3946 evaluation kit (EV kit) is an assembled demonstration board that provides optical evaluation of the MAX3946 1.0625Gbps to 11.3Gbps laser driver. The controlling software communicates with the EV kit through the USB port and provides simplified control of all the device functions. The EV kit can be fully powered by the USB port, or the user can choose to power the device by a single external 3.3V supply while the USB port supplies the on-board microcontroller. The flex-cable connection on the EV board allows attachment of lasers incorporating flex cables.

## EV Kit Contents

### ◆ MAX3946 EV Kit Board

## Features

- ◆ Drives Differential-Connected Lasers
- ◆ Software Control of the MAX3946
- ◆ Power Supplied Through USB or External Connection

## Ordering Information

PART	TYPE
MAX3946EVKIT	EV Kit

## Component List

DESIGNATION	QTY	DESCRIPTION
C1–C6, C8, C9, C16, C41	10	0.01 $\mu$ F $\pm$ 10% ceramic capacitors (0402)
C7, C10, C12, C14	4	0.1 $\mu$ F $\pm$ 20% ceramic capacitors (0204)
C11, C13, C15	3	10 $\mu$ F $\pm$ 10% ceramic capacitors (0805)
C17–C20	0	Not installed
C21, C22	2	33pF $\pm$ 10% ceramic capacitors (0402)
C25, C26, C27, C49, C52	5	0.1 $\mu$ F $\pm$ 10% ceramic capacitors (0402)
C34, C55	2	1 $\mu$ F $\pm$ 10% ceramic capacitors (0603)
C35, C37, C38	3	4.7 $\mu$ F $\pm$ 10% ceramic capacitors (0805)
D6	1	Green LED
J1, J2	2	SMA edge-mount connectors
J3, J4, TP3, TP7, TP10–TP13	8	Test points
J8	1	USB connector
JU2	1	2 x 6 header, 0.1in centers
L1	1	22 $\mu$ H $\pm$ 20% inductor Taiyo Yuden CBC3225T220M
L2, L3	2	18nH $\pm$ 2% inductors (0402)
L4, L11, L12	3	Ferrite beads (0402) Murata BLM15GG471

DESIGNATION	QTY	DESCRIPTION
L10, L14, L15, L16	4	10 $\mu$ H $\pm$ 10% inductors (0603)
R1, R2	2	1.00k $\Omega$ $\pm$ 1% resistors (0402)
R3	1	680 $\Omega$ $\pm$ 5% resistor (0402)
R5, R6	2	20 $\Omega$ $\pm$ 5% resistors (0603)
R7, R8	2	100 $\Omega$ $\pm$ 5% resistors (0603)
R15, R50	2	4.7k $\Omega$ $\pm$ 5% resistors (0402)
R16, R17	2	1k $\Omega$ $\pm$ 5% resistors (0402)
R18, R52, R55, R66, R73	5	51 $\Omega$ $\pm$ 5% resistors (0402)
R24	1	1.5k $\Omega$ $\pm$ 5% resistor (0402)
R31, R51, R53	3	10k $\Omega$ $\pm$ 5% resistors (0402)
SW1	1	SPDT switch
U1	1	1.0625Gbps to 11.3Gbps, SFP+ laser driver (24 TQFN-EP*) Maxim MAX3946ETG+
U2	1	Low-noise LDO regulator (8 TDFN-EP*) Maxim MAX8902AATA+
U6	0	User-supplied TOSA
U10	1	Microcontroller (28 SO) Microchip PIC16C745-I/SO
Y2	1	6MHz crystal ECS Inc. ECS-60-32-5PXDN
—	1	PCB: MAX3946 EVALUATION BOARD, REV A

\*EP = Exposed pad.

Evaluates: MAX3946



# MAX3946 Evaluation Kit

## Quick Start

**Note:** In the following sections, software-related items are identified by bolding. Text in **bold** refers to items directly from the EV kit software. Text in **bold and underlined** refers to items from the Windows® operating system.

- 1) Solder a laser to connection U6. See Figure 1 for more information about the laser connection.
- 2) Set SW1 to the desired power-supply option (USB or external supply).
- 3) If an external power supply is used, set the voltage to 3.3V, the current limit to 300mA, and connect the supply to the board.
- 4) To download the latest version of the EV kit software (MAX3946Rev1.ZIP), visit the Maxim website at [www.maxim-ic.com/evkitsoftware](http://www.maxim-ic.com/evkitsoftware). Unzip the file to a local folder and run the installation file (setup.EXE). Installation requires administrative rights and can also require Internet access to download necessary drivers.
- 5) After installation is complete, follow this path to start the program: **Start**→**All Programs**→**MAX3946EVGUI**→**MAX3946EVGUI**.
- 6) Connect the computer to the EV kit with a USB cable (A-male to Mini-B-male). LED D6 should illuminate, indicating that USB power is detected. Click the **USB Connect** button in the software to initiate communication to the EV kit. The **Status** indicator turns green when communication is established.
- 7) Connect a 50Ω source to TIN- and TIN+ (J1 and J2). Set the source differential amplitude to 500mVP-P.
- 8) Connect the output from the TOSA to an optical receiver (optical-to-electrical converter or optical input head on an oscilloscope).
- 9) All device controls are available in the software. Fault and warning indicators are displayed on the right side of the graphical user interface (GUI) window. When a hard fault has occurred the device goes into latched shutdown. The source of the fault should be removed and the **DISABLE** checkbox should be toggled to reset the part.
- 10) The registers contain a default setting and can be read using the **Tx Read All** button. For detailed register functions, refer to the MAX3946 IC data sheet.
- 11) To enable the part, the **DISABLE** checkbox should be toggled (checked and then unchecked) and the **Tx Enable** checkbox should be checked. After doing this, click the **Tx Read All** button twice and verify whether any faults are indicated. All fault indicators should be green if everything is set up properly.
- 12) The **Tx De-emphasis Control** edit box can be used to adjust the eye diagram. After choosing a new setting, click the **Tx De-emphasis Control** edit box **Load** button followed by the **IMod** edit box **Load** button. Doing so loads the new preemphasis setting to the modulation current driver. Further improvements to the eye diagram can be accomplished by adjusting the component values of L2, L3, L11, L12, and R5-R8.

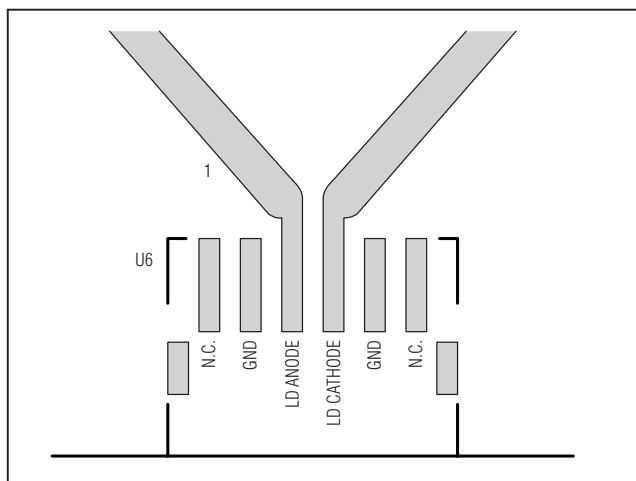

Figure 1. TOSA Connection

Windows is a registered trademark of Microsoft Corp.

# MAX3946 Evaluation Kit

Evaluates: MAX3946

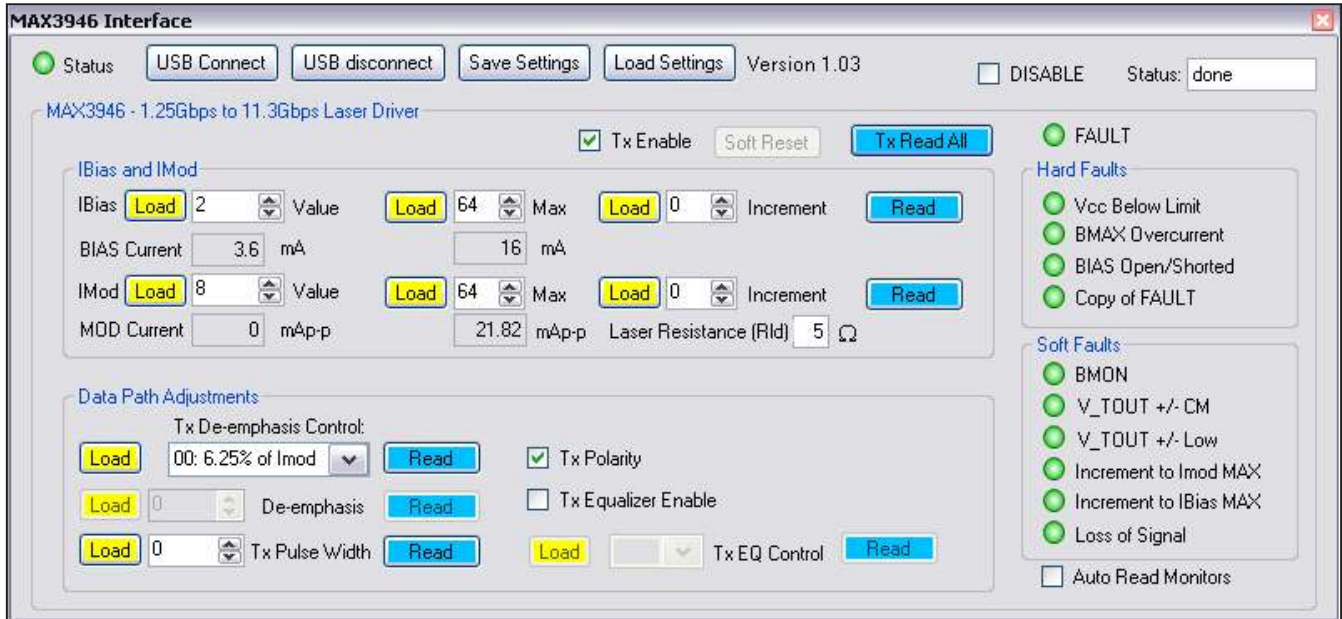

Figure 2. MAX3946 EV Kit Software

## Detailed Description of Software

### Graphical User Interface (GUI)

The GUI consists of three main blocks: bias and modulation control, data path adjustments, and fault indicators.

#### Bias and Modulation Control

For bias and modulation current there are three controls: set current, set maximum, and increment. The left-side data-entry boxes allow the user to write to the SET\_IBIAS or SET\_IMOD register directly, as long as that value is below the value loaded in the IBIASMAX and IMODMAX registers. The middle data-entry boxes allow the user to write to the IBIASMAX and IMODMAX registers. The right-side data-entry boxes allow the user to increment or decrement the bias and modulation current registers over a  $\pm 15$  LSB range by writing to the BIASINC and MODINC registers. The appropriate **Load** button must be clicked to initiate a register write. The **Read** buttons read and display the values held in the SET\_IBIAS/SET\_IMOD, IBIASMAX/IMODMAX, and BIASINC/MODINC registers. Calculated bias and modulation current values are displayed below the data-entry boxes. The modulation current is calculated based on the laser's effective series resistance provided by the user in the **Laser Resistance (Rld)** edit box.

#### Data Path Adjustments

This block allows control of preemphasis, the input equalization, data polarity, and pulse-width adjustment. The **Tx De-emphasis Control** edit box has a pull-down box with four options for setting the TXDE\_MD bits in the TXCTRL register. When manual control is selected, the **De-emphasis** edit box becomes available to write values to the SET\_TXDE register. When the **Tx Polarity** checkbox is checked the TOUT+ pin sinks current when TIN+ is high (typical setup). The output polarity is inverted if the box is unchecked. Check the **Tx Equalizer Enable** checkbox to enable the input equalizer. Once checked, the **Tx EQ Control** edit box becomes available to write to the SET\_TXEQ register.

#### Fault Indicators

Along the right-hand side of the GUI are fault indicators that show the status of the TXSTAT1 and TXSTAT2 registers. Hard faults disable the device and require a toggling of the **DISABLE** checkbox to restart the device (once the source of the fault has been removed). Soft faults operate as warnings, but do not disable the part. Automatic updating of the fault monitors can be enabled by checking the **Auto Read Monitors** checkbox.

# Evaluates: MAX3946

## MAX3946 Evaluation Kit

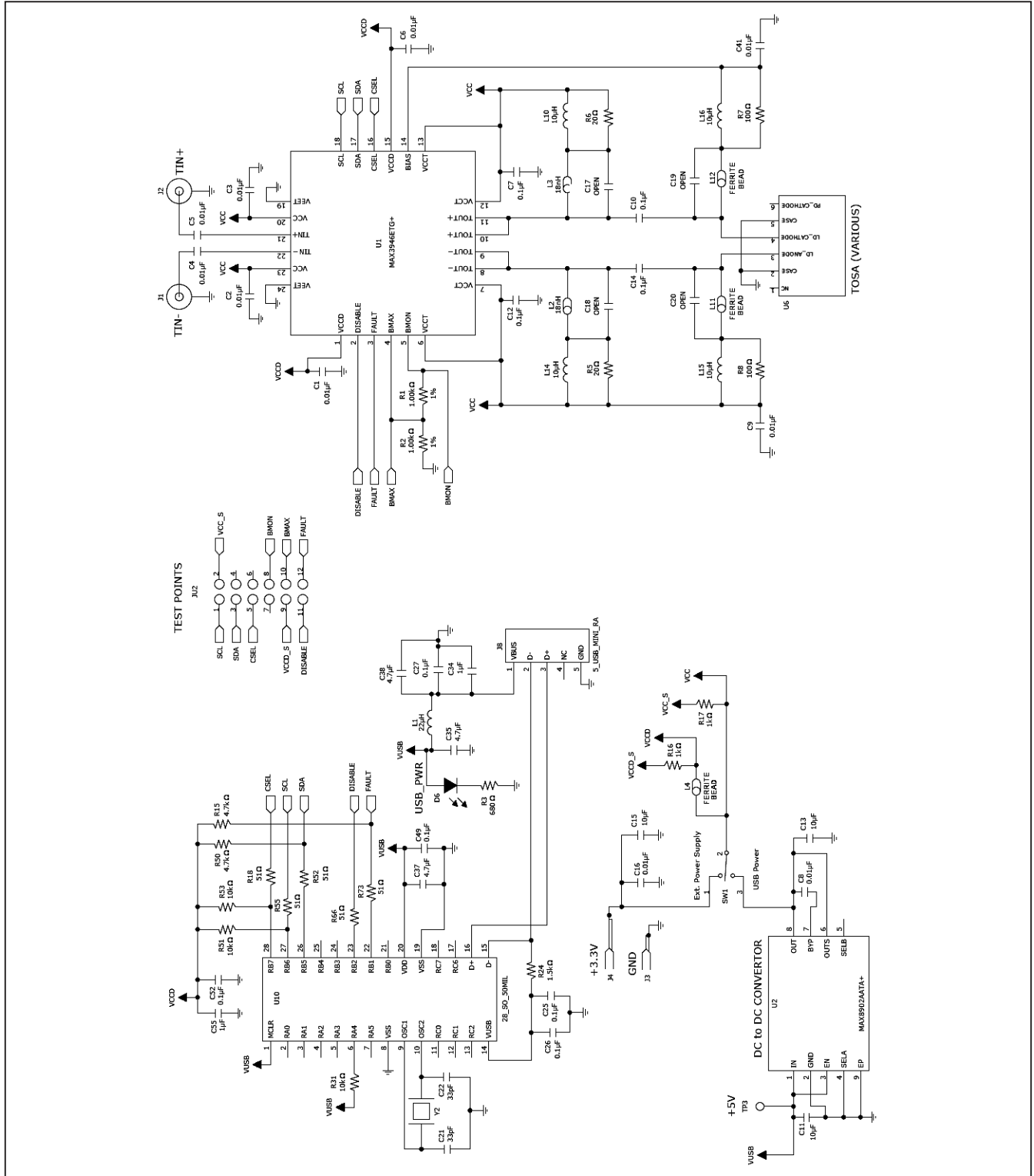

Figure 3. MAX3946 EV Kit Schematic

# MAX3946 Evaluation Kit

Evaluates: MAX3946

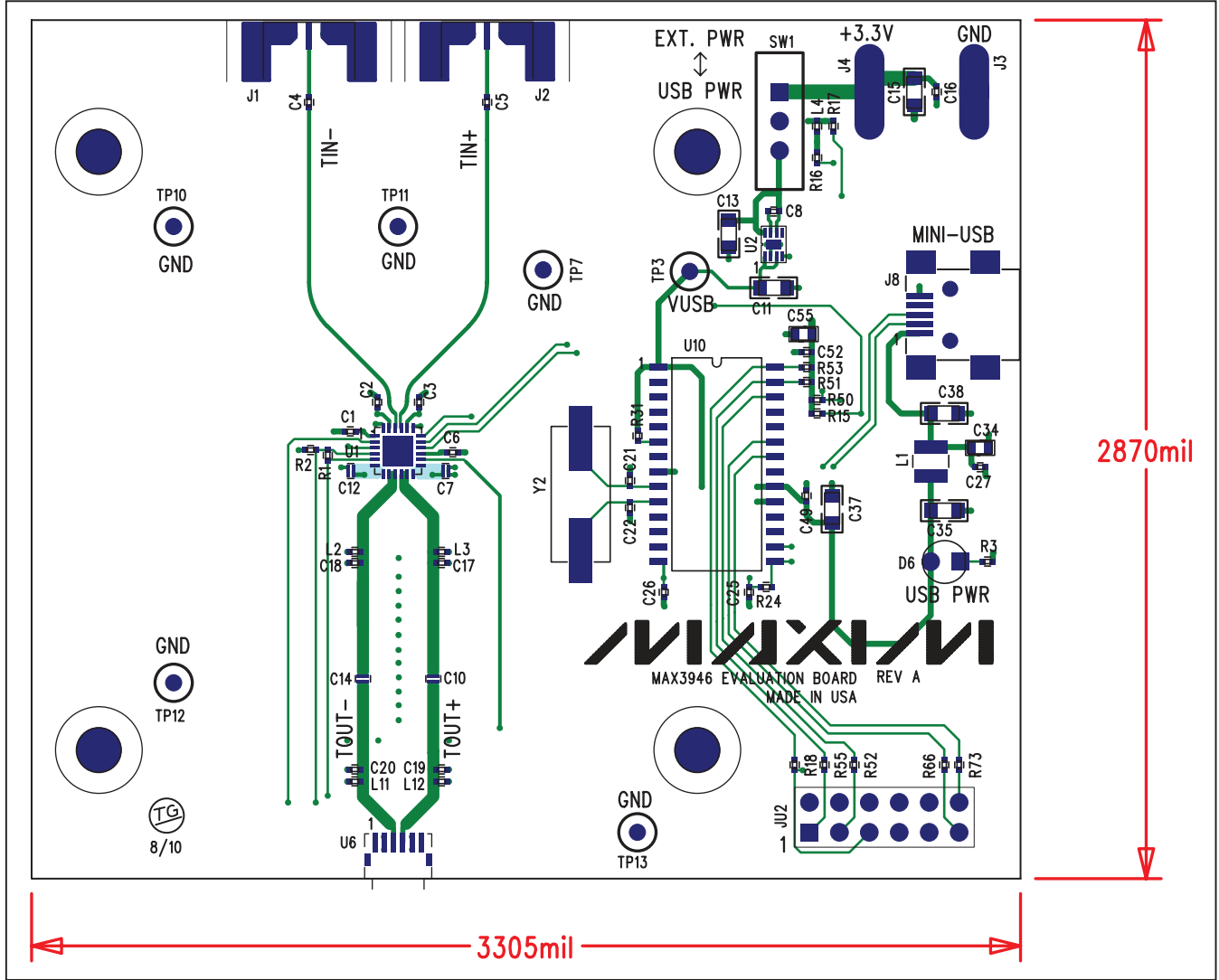

Figure 4. MAX3946 EV Kit Component Placement Guide—Component Side

# MAX3946 Evaluation Kit

Evaluates: MAX3946

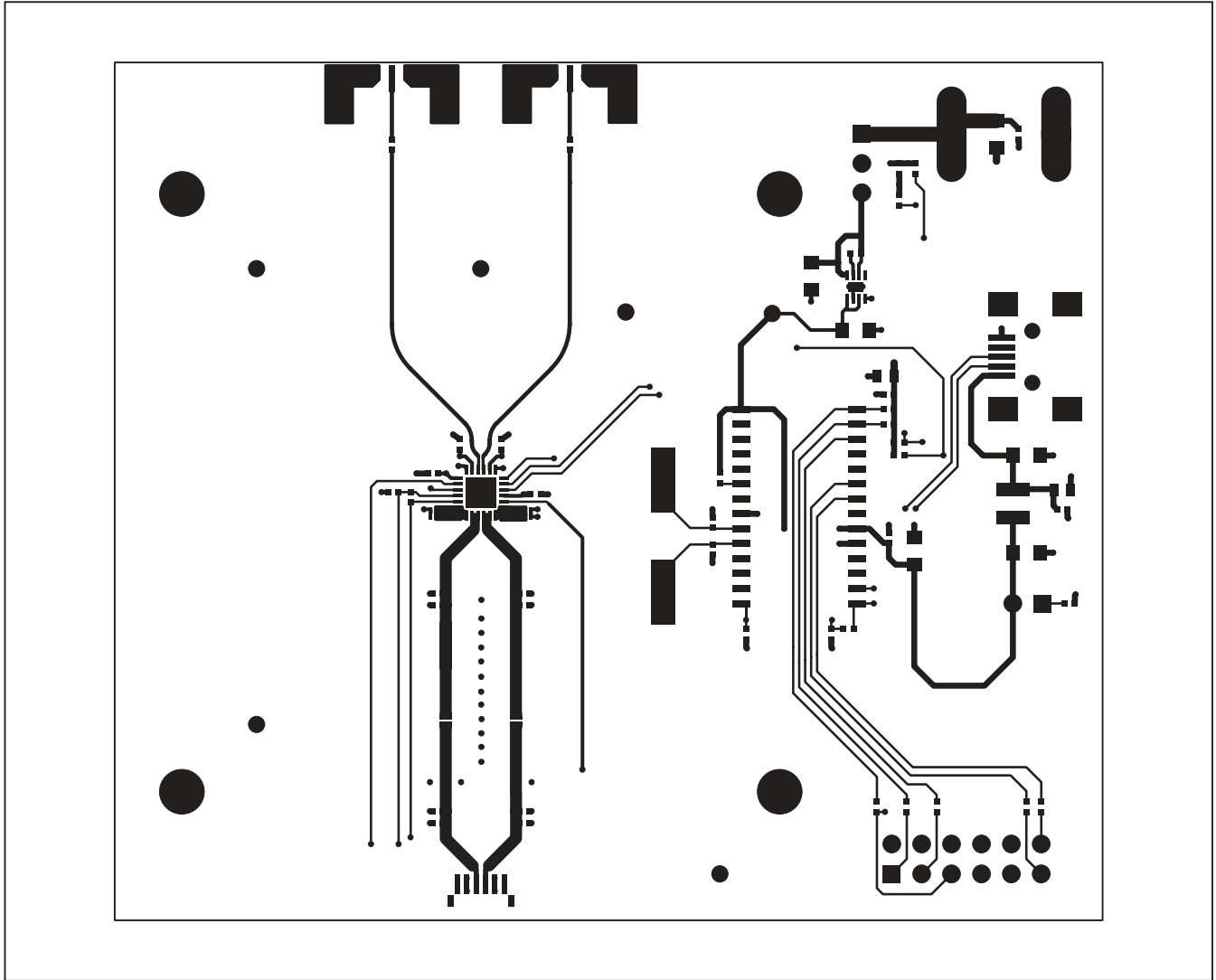

Figure 5. MAX3946 EV Kit PCB Layout—Top Side

# MAX3946 Evaluation Kit

Evaluates: MAX3946

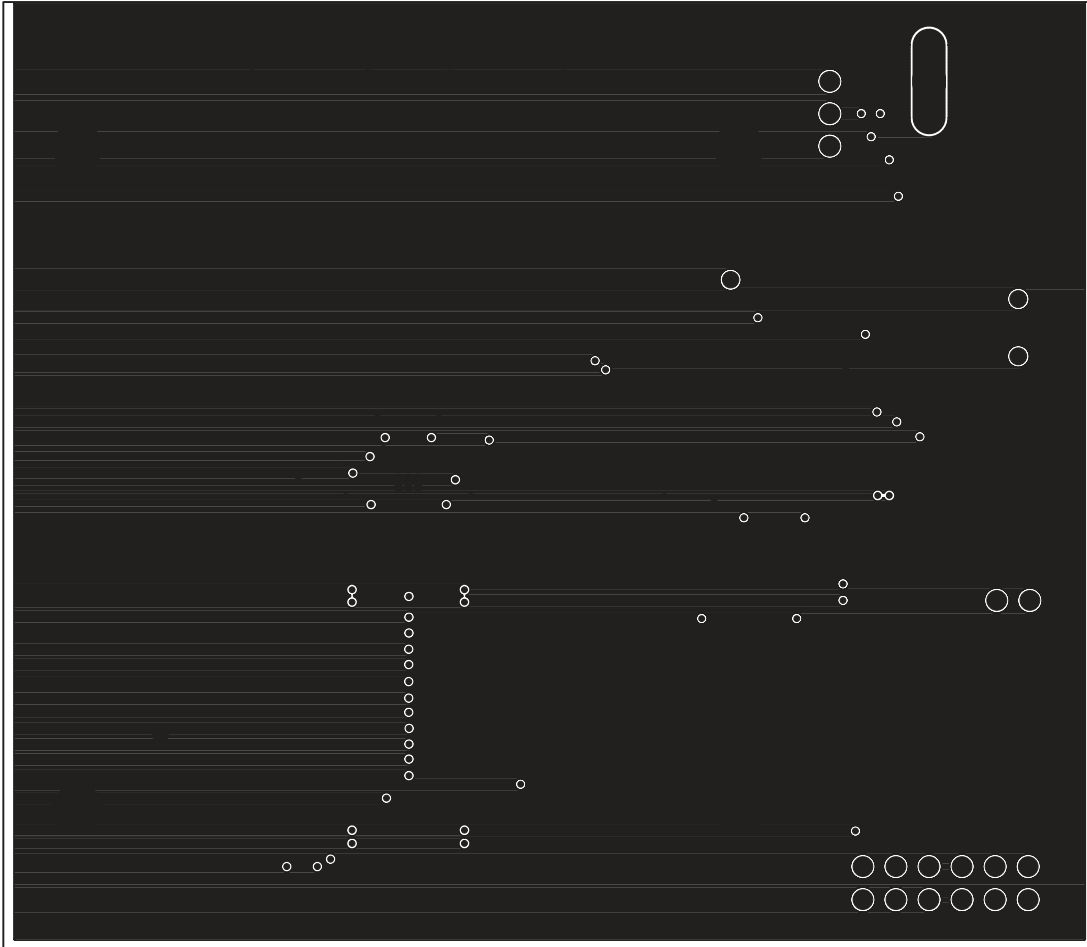

Figure 6. MAX3946 EV Kit PCB Layout—Ground Plane

# MAX3946 Evaluation Kit

Evaluates: MAX3946

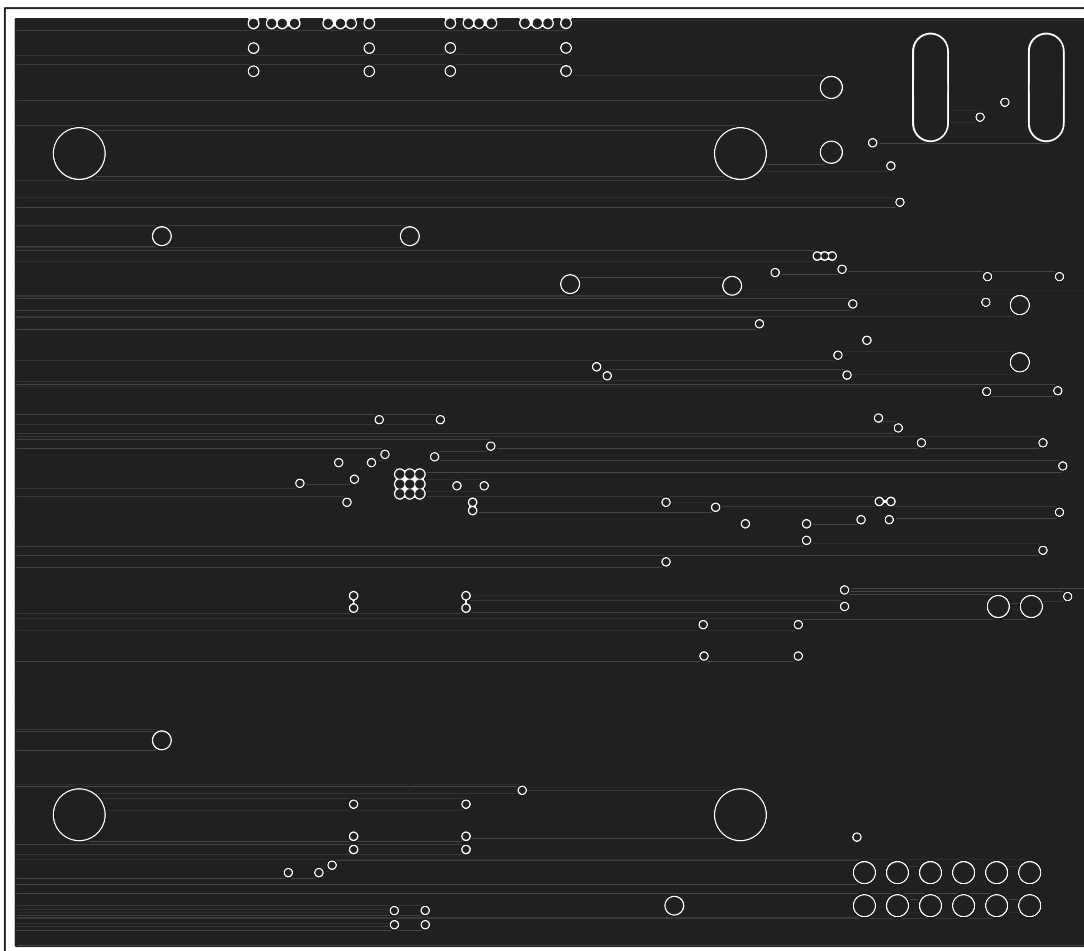

Figure 7. MAX3946 EV Kit PCB Layout—Power Plane



# MAX3946 Evaluation Kit

Evaluates: MAX3946

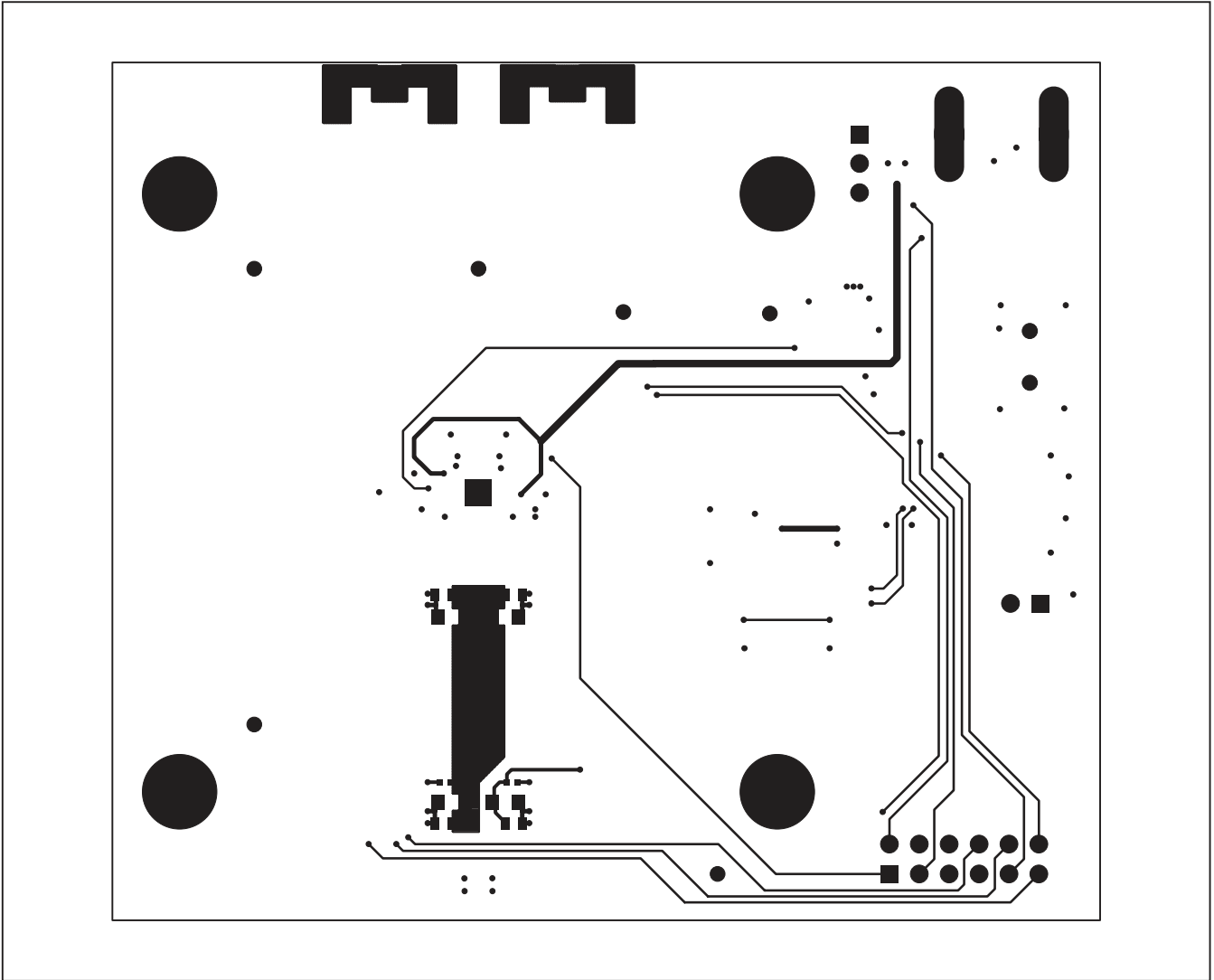

Figure 8. MAX3946 EV Kit PCB Layout—Solder Side

# MAX3946 Evaluation Kit

Evaluates: MAX3946

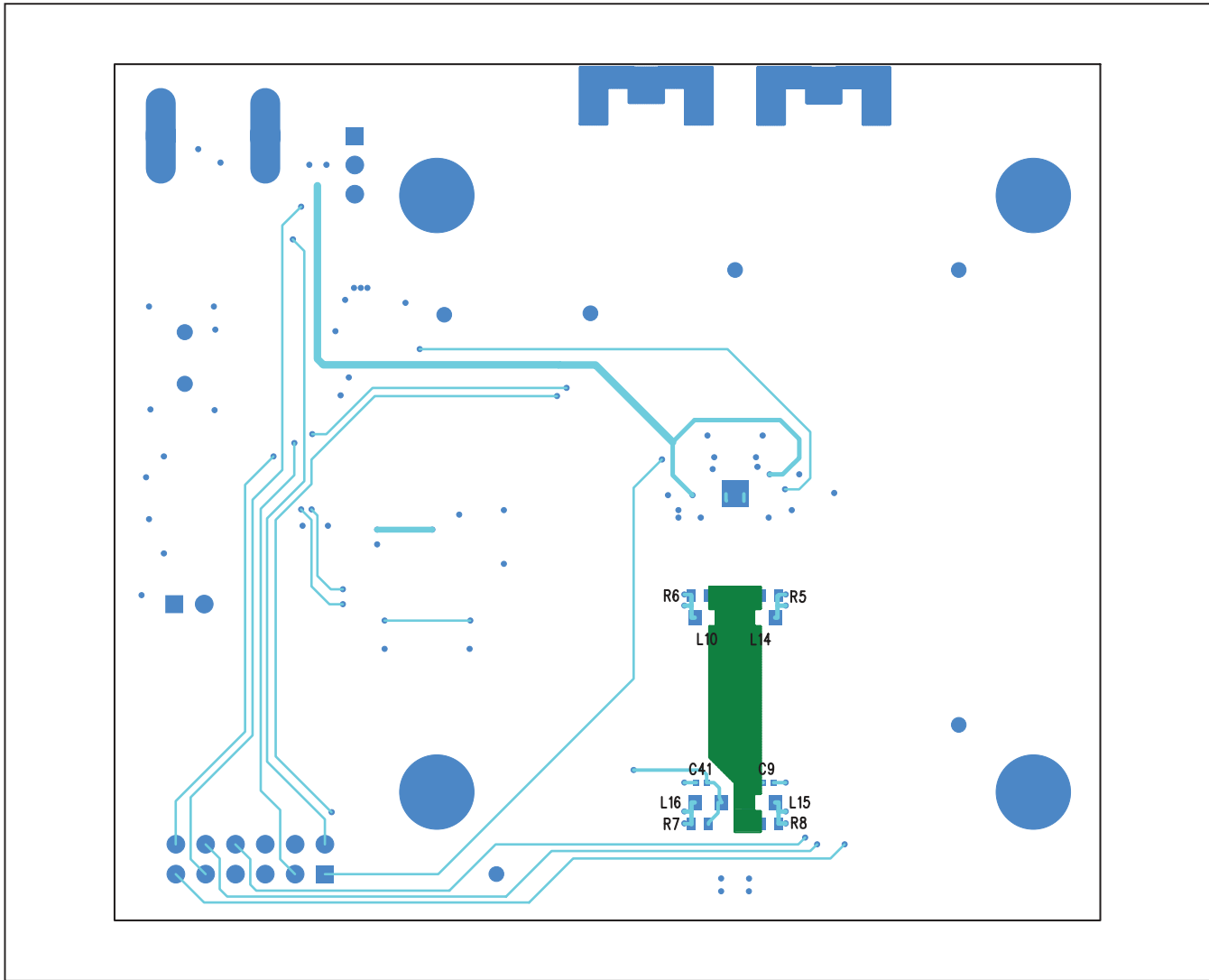

Figure 9. MAX3946 EV Kit Component Placement Guide—Solder Side

# MAX3946 Evaluation Kit

## Revision History

REVISION NUMBER	REVISION DATE	DESCRIPTION	PAGES CHANGED
0	2/11	Initial release	—

**Evaluates: MAX3946**

*Maxim cannot assume responsibility for use of any circuitry other than circuitry entirely embodied in a Maxim product. No circuit patent licenses are implied. Maxim reserves the right to change the circuitry and specifications without notice at any time.*

**Maxim Integrated Products, 120 San Gabriel Drive, Sunnyvale, CA 94086 408-737-7600** \_\_\_\_\_ 11