Smart card interface evaluation board based on the ST8034AT

Data brief

**Features**

- Smartcard connector for testing with a smartcard
- Labeled testpoints provide accessibility to all the signals
- Board design allows standalone operation for basic tests
- Interface to an MCU block and simple board configurability allow full functioning in applications (i.e. set-top box)
- Onboard 10 MHz crystal clock oscillator can be used to provide card clock in standalone operation
- Card clock source selection switch allows selection between the onboard crystal oscillator as card clock source, or an external clock source provided by the microcontroller block through the MCU interface together with the data signals
- Provides easy, flexible card supply voltage selection either by onboard configuration switches or remotely by the microcontroller
- RoHS compliant

Description

The ST8034xx interface devices are placed between the smartcard and the microcontroller to provide all supply, protection, detection and control functions, with a minimum of external components. The STEVAL-IPT006V1 product evaluation board allows easy demonstration and testing of these features. The board can also be used as a functional block for a complete application, as it is designed both for standalone operation or to be controlled by the microcontroller. The board is fully configurable to maintain flexibility for various use scenarios. It includes standard interfaces on both sides (smartcard connector, MCU interface connector) and easily accessed, labeled testpoints on all signals.

The STEVAL-IPT006V1 product evaluation board addresses market segments including: POS, set-top boxes, pay TV, identification, banking and tachographs.

1 Schematic diagram

Figure 1: STEVAL-IPT006V1 circuit schematic

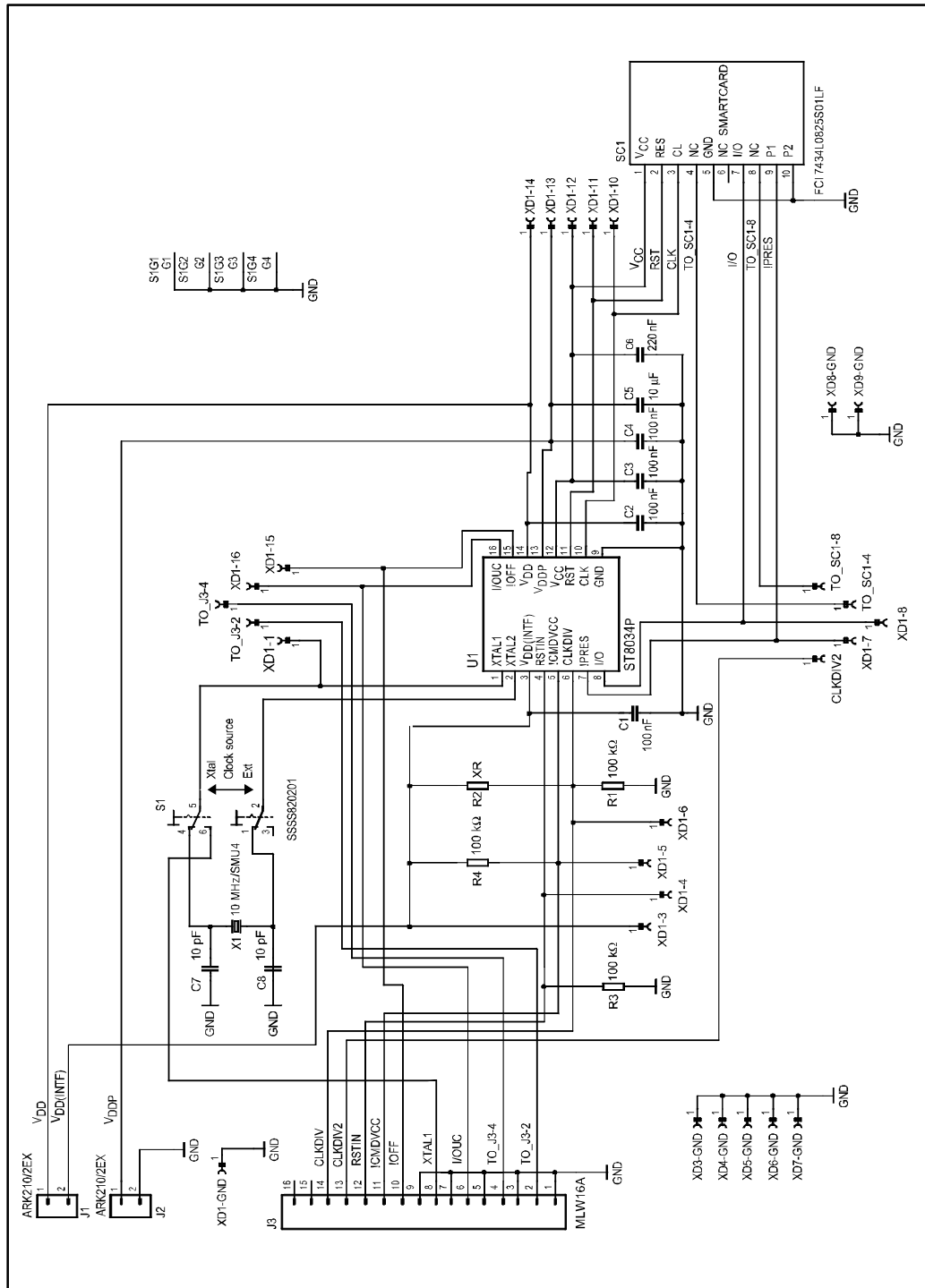

2 Revision history

Table 1: Document revision history

Date	Revision	Changes
11-Nov-2013	1	Initial release.

Please Read Carefully

Information in this document is provided solely in connection with ST products. STMicroelectronics NV and its subsidiaries ("ST") reserve the right to make changes, corrections, modifications or improvements, to this document, and the products and services described herein at any time, without notice.

All ST products are sold pursuant to ST's terms and conditions of sale.

Purchasers are solely responsible for the choice, selection and use of the ST products and services described herein, and ST assumes no liability whatsoever relating to the choice, selection or use of the ST products and services described herein.

No license, express or implied, by estoppel or otherwise, to any intellectual property rights is granted under this document. If any part of this document refers to any third party products or services it shall not be deemed a license grant by ST for the use of such third party products or services, or any intellectual property contained therein or considered as a warranty covering the use in any manner whatsoever of such third party products or services or any intellectual property contained therein.

UNLESS OTHERWISE SET FORTH IN ST'S TERMS AND CONDITIONS OF SALE ST DISCLAIMS ANY EXPRESS OR IMPLIED WARRANTY WITH RESPECT TO THE USE AND/OR SALE OF ST PRODUCTS INCLUDING WITHOUT LIMITATION IMPLIED WARRANTIES OF MERCHANTABILITY, FITNESS FOR A PARTICULAR PURPOSE (AND THEIR EQUIVALENTS UNDER THE LAWS OF ANY JURISDICTION), OR INFRINGEMENT OF ANY PATENT, COPYRIGHT OR OTHER INTELLECTUAL PROPERTY RIGHT.

ST PRODUCTS ARE NOT DESIGNED OR AUTHORIZED FOR USE IN: (A) SAFETY CRITICAL APPLICATIONS SUCH AS LIFE SUPPORTING, ACTIVE IMPLANTED DEVICES OR SYSTEMS WITH PRODUCT FUNCTIONAL SAFETY REQUIREMENTS; (B) AERONAUTIC APPLICATIONS; (C) AUTOMOTIVE APPLICATIONS OR ENVIRONMENTS, AND/OR (D) AEROSPACE APPLICATIONS OR ENVIRONMENTS. WHERE ST PRODUCTS ARE NOT DESIGNED FOR SUCH USE, THE PURCHASER SHALL USE PRODUCTS AT PURCHASER'S SOLE RISK, EVEN IF ST HAS BEEN INFORMED IN WRITING OF SUCH USAGE, UNLESS A PRODUCT IS EXPRESSLY DESIGNATED BY ST AS BEING INTENDED FOR "AUTOMOTIVE, AUTOMOTIVE SAFETY OR MEDICAL" INDUSTRY DOMAINS ACCORDING TO ST PRODUCT DESIGN SPECIFICATIONS. PRODUCTS FORMALLY ESCC, QML OR JAN QUALIFIED ARE DEEMED SUITABLE FOR USE IN AEROSPACE BY THE CORRESPONDING GOVERNMENTAL AGENCY.

Resale of ST products with provisions different from the statements and/or technical features set forth in this document shall immediately void any warranty granted by ST for the ST product or service described herein and shall not create or extend in any manner whatsoever, any liability of ST.

ST and the ST logo are trademarks or registered trademarks of ST in various countries.

Information in this document supersedes and replaces all information previously supplied.

The ST logo is a registered trademark of STMicroelectronics. All other names are the property of their respective owners.

© 2013 STMicroelectronics - All rights reserved

STMicroelectronics group of companies

Australia - Belgium - Brazil - Canada - China - Czech Republic - Finland - France - Germany - Hong Kong - India - Israel - Italy
- Japan - Malaysia - Malta - Morocco - Philippines - Singapore - Spain - Sweden - Switzerland - United Kingdom - United
States of America

www.st.com