

DIGI-KEY

THIRD ANGLE PROJECTION

ALL DIMENSIONS ARE IN MILLIMETERS.

DO NOT SCALE DRAWING

General dimension tolerance : ± 0.5

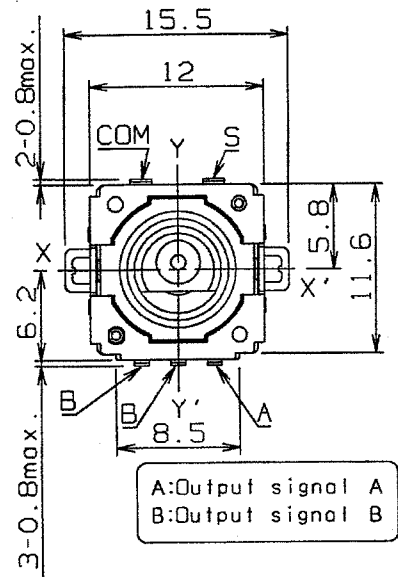
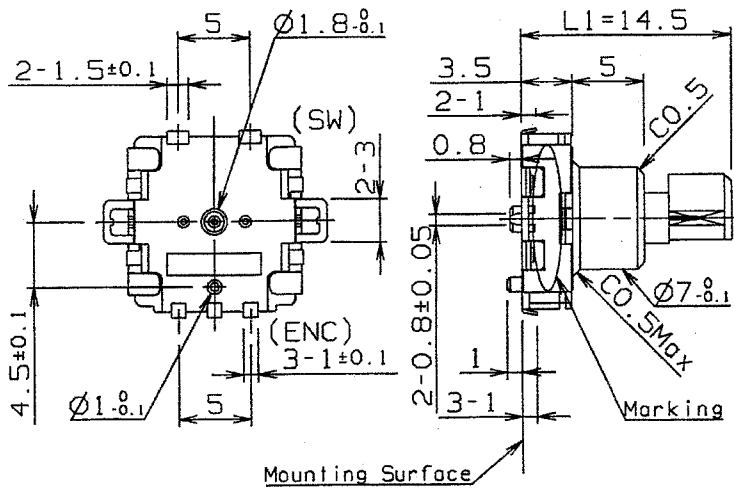

Shaft shape and dimension

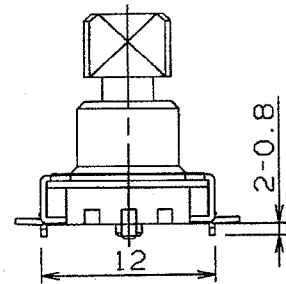
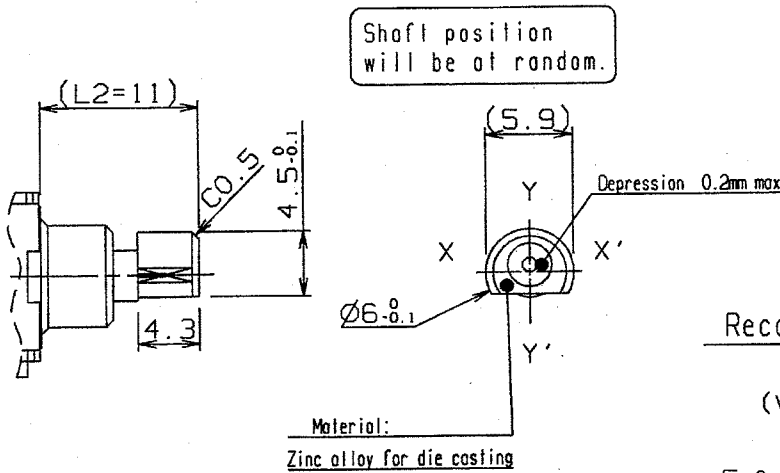

Recommended land pattern plan.

(Tolerance : ± 0.1)
(View from mounting side)

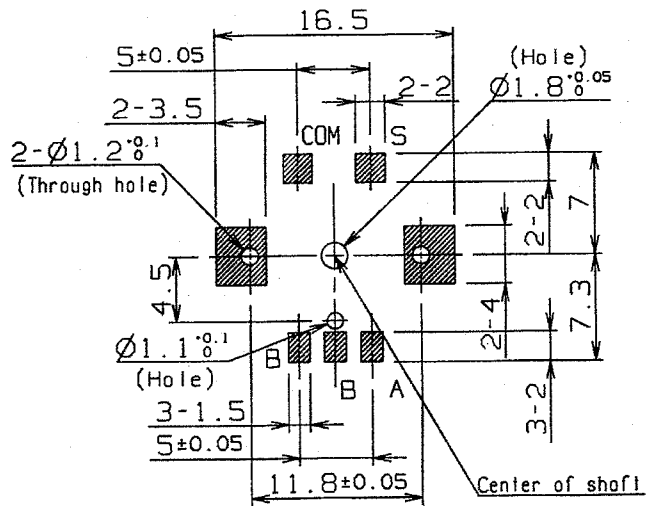

DESIGN	A. Matsumoto	Mar. 21. '13	NAME	11mm GS ENCODER	ISSUE	REVISIONS	DATE
DRAW			TYPE NO.	EVE SBB FE5 16B	DRAWING NO. RV-H-1781		
CHECK					1/8		
APPROVAL	M. Sawada	Mar. 21. '13					

General

1. Scope: This specification applies to rotary encoder(incremental type) used in electronic equipment.
2. Standard atmospheric conditions: Unless otherwise specified. The standard range of atmospheric conditions for making measurements and tests is as follows.
 Ambient temperature : 15°C ~ 35°C
 Relative humidity : 25% ~ 75%
 Air pressure : 86kPa ~ 106kPa
3. Operating temperature range : -40°C ~ +85°C
4. Storage temperature range : -40°C ~ +85°C
5. Rated voltage : Encoder D.C 10V
 Switch D.C 16V
6. Rated current : Encoder D.C 1mA
 Switch D.C 20mA

Production country : VIETNAM

Mechanical characteristics

Item		Conditions	Specifications
1	Rotation angle		360° (Endless)
2	Rotation torque (Detent torque)	Operating temperature 5°C ~ 85°C	8.0 mN·m ± 4.0 mN·m
		-20°C ~ 5°C	40 mN·m max.
		-40°C ~ -20°C	50 mN·m max.
3	Detent points		32 detent points
4	Each detent angle		11.25° ± 3°
5	Shaft pull-push strength	Pull and push static load of 100N shall be applied to the shaft in the axial direction for 10 second. (Mount the product to P.W.B.)	Without damage or excessive play in shaft. No excessive abnormality in rotational feeling. And electrical characteristics shall be satisfied.
6	Shaft side-load strength	A momentary load of 0.5 Nm shall be applied at the point 5mm from the tip of the shall in a direction perpendicular to the axis of shaft for 10 second. (Mount the product to P.W.B.)	Without excessive play or bending in shaft. No excessive abnormality in rotational feeling. And electrical characteristics shall be satisfied.
7	Shaft wobble	A momentary load of 50 mNm shall be applied at the point 2mm from the tip of the shall in a direction perpendicular to the axis of shaft. (Mount the product to P.W.B.)	1.0xL/30 mm(P-P)max. L :Distance between mounting surface and measuring point on the shaft.
8	Shaft play in rotational wobble	Measure with jig for rotational angle.	2° max.(Initial)

NAME	11mm GS ENCODER	ISSUE	REVISIONS	DATE
		TYPE NO.	EVE SBB FE5 16B	DRAWING NO.

Electrical characteristics(encoder)

Item		Conditions	Specifications
1	Output signal	(Output of phase difference Fig-1)	A,B 2 signals.
2	Output resolution	Number of pulses in 360° rotation.	16 Pulse / 360°
3	Contact resistance	Measurement shall be stable condition which a output signal is ON condition.	1Ω max.
4	Bouncing	Measurement circuit diagram.(Fig-2) At rotational speed 60 min ⁻¹ <Phase t1, t3 (Fig-3)> (Passing time between 3.5V and 1.5V)	t1, t3: 5 ms max.
5	Sliding noise phase t2	Take sliding noise as time in the code-on area between bouncing(t1,t3) and voltage change exceed 1.5V.(Fig-3) Rotate shaft at speed 60±3 min ⁻¹ and measure.	3 ms max.
6	Phase-difference	Measurement shall be made under the condition which the shaft is rotated at 60 min ⁻¹ .	T1, T2, T3, T4 (Fig-1) 4 ms min.
7	Insulation resistance	Measurement shall be made under the condition which a voltage of 250V D.C. is applied between individual terminals and a shaft.	50MΩ min.
8	Withstand voltage	A voltage of 300V A.C. shall be applied for 1min. between individual terminals and a shaft.	Without arcing or breakdown.

Switch characteristics(switch)

Item		Conditions	Specifications
1	Switch type		Push type S.P.S.T.
2	Contact resistance	Measurement the contact resistance between COM and SW when push SW is ON. Applying force: 6.0N	100mΩ max.
3	Switch operation force	Measure the max.load until switch turned on when pressing the shaft to the operation direction of push SW.	4.0 N ± 2.0 N
4	Push stroke	Measure the distance until switch turned on when pressing the shaft to the operation direction of push SW.	1.5 mm ± 0.5 mm (At push force 6.0N)
5	Bouncing	Measurement circuit diagram.(Fig-4) At operation speed 3~4 times/s <Phase t4, t5 (Fig-5)> (Passing time between 1.5V and 3.5V)	t4, t5: 10 ms max.
6	Insulation resistance	Measurement shall be made under the condition which a voltage of 250V D.C. is applied between individual terminals and a shaft.	50MΩ min.
7	Withstand voltage	A voltage of 300V A.C. shall be applied for 1min. between individual terminals and a shaft.	Without arcing or breakdown.

NAME	11mm GS ENCODER	ISSUE	REVISIONS	DATE
TYPE NO.	EVE SBB FES 16B	DRAWING NO.	RV-H- 1781	3/8

Phase difference.
(Fig-1)

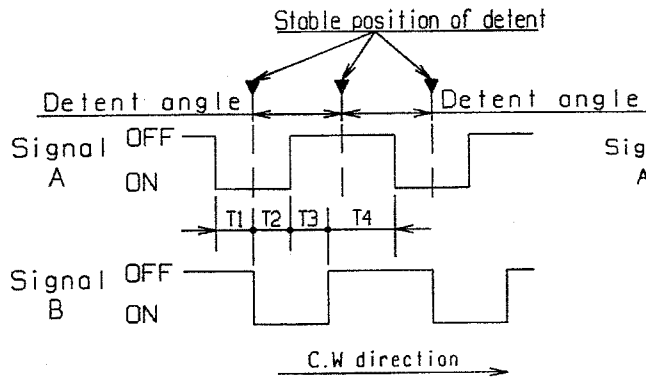

At each detent position, output between COM and A is stable ON or OFF.
(Output between COM and B is not specified.)

Measurement circuit diagram.
(Fig-2)

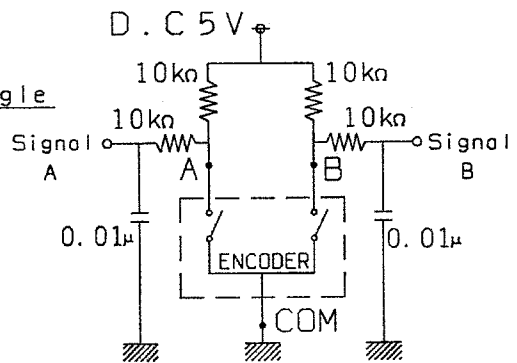

Bouncing phase(Fig-3)

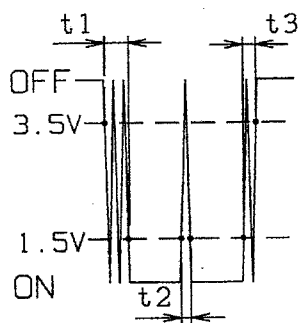

Measurement circuit diagram.(Fig-4)

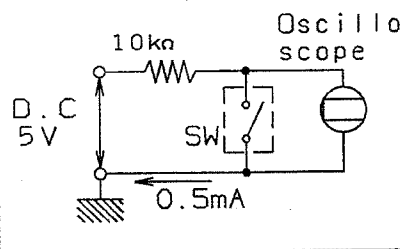

Bouncing phase(Fig-5)

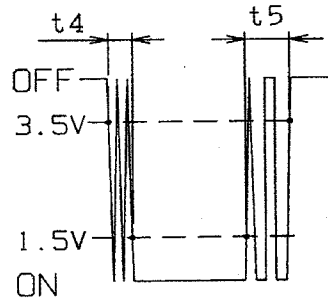

Encoder terminal layout and switch circuit diagram.
(Fig-6)

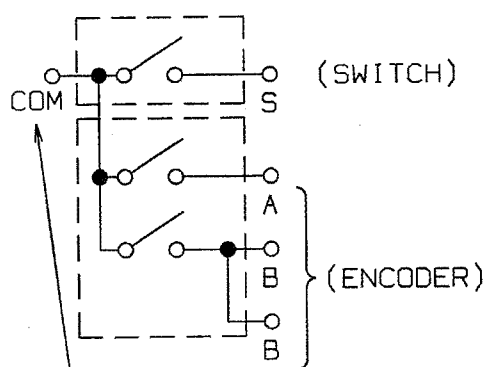

(Notice)
Common terminal is shared
between encoder and switch

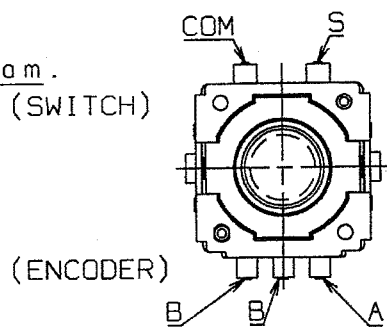

ENCODER: A:Output signal A
B:Output signal B
SWITCH: S:Output signal for switch

NAME 11mm GS ENCODER

ISSUE

REVISIONS

DATE

TYPE NO. EVE SBB FE5 16B

DRAWING NO. RV-H- 1781

4/8

Durability

Item	Conditions	Specifications
1 Rotation life (Encoder)	The shaft of encoder shall be rotated to 100k cycles at a speed of 600 cycles/h without electrical load after which measurements shall be made.	Rotation torque: Initial torque $\pm 70\%$ Phase-difference: 2.5 ms min. Contact resistance: 100 Ω max. Electrical characteristics item: 4,5,7,8 The same as the initial specifications.
2 Push operating life (Switch)	Apply 6.0N push strength to shaft to the switch operating direction. The shaft of encoder shall be pushed to 100k times at a speed of 600 times/h without electrical load after which measurements shall be made.	Operation force: Initial operation force $\pm 40\%$ Contact resistance: 1 Ω max. Switch characteristics item: 4,5,6,7 The same as the initial specifications.
3 Heat temperature	The encoder shall be stored at a temperature of $85\pm 3^{\circ}\text{C}$ for $240\pm 10\text{h}$ in a thermostatic chamber. And then the encoder shall be subjected to standard atmospheric conditions for 1.5h after which measurements shall be made. (Without electrical load)	Contact resistance: 100 Ω max.
4 Humidity	The encoder shall be stored at a temperature of $60\pm 3^{\circ}\text{C}$ with relative humidity of 90% to 95% for $240\pm 10\text{h}$ in a thermostatic chamber. And then the encoder shall be subjected to standard atmospheric conditions for 1.5h after which measurements shall be made. (Without electrical load)	SW Contact resistance: 200 $\text{m}\Omega$ max. Mechanical characteristics item: 2 Electrical characteristics item: 4,5,6,7,8 Switch characteristics item: 3,4,5,6,7
5 Low temperature	The encoder shall be stored at a temperature of $-40\pm 3^{\circ}\text{C}$ for $240\pm 10\text{h}$ in a thermostatic chamber. And then the encoder shall be subjected to standard atmospheric conditions for 1.5h after which measurements shall be made. (Without electrical load)	The same as the initial specifications.

Handling of approval specification :

1. This specification from specify this item only. Please perform your approval test in the actual application conditions beforehand.
2. Please return one copy of this specification from with your approval stamp or signature to us. Otherwise, it might be happened that the item can not be supplied.
3. Writings in this specification form are subject to change through precautions.

Marking

1. Date code
2. VN (Marking of distinction between production country)

NAME 11mm GS ENCODER	ISSUE	REVISIONS	DATE
	DRAWING NO. RV-H- 1781		
TYPE NO. EVE SBB FES 16B			5/8

⚠ Application Notes :

1. Prohibited items on fire and smoking

Absolutely avoid use of a product beyond its rated range because doing so may cause a fire. If misuse or abnormal use may result under conditions in which the product is used out of its rated range, take proper measures such as current interruption using a protective circuit.

The grade of nonflammability for resin used in product is "94HB," which is based on UL94 Standards (flammability test for plastic materials).

Prohibit use in a location where a spreading fire may be generated or prepare against a spreading fire.

2. For use in equipment for which safety is requested

Although care is taken to ensure product quality, inferior Characteristics, short circuits, and open circuits are some problems that might be generated. To design an equipment which places maximum emphasis on safety, review the affect of any single fault of a product in advance and perform virtually fail-safe design to ensure maximum safety by:

- Preparing a protective circuit or a protective device to improve system safety, and set
- Preparing a redundant circuit to improve system safety so that the single fault of a product does not cause a dangerous situation.

3. Reliability

Storage condition

Do not store the product under high temperatures and/or high humidity, or in a location where corrosive gas may be generated.

Store the product at room temperature and room humidity in a packed condition.

Use them within a maximum of 6 months.

Check the date of manufacture on the package box

and apply the "first-in-first-out" rule.

If unpacked product must be stored as inventory, Store them in polyethylene bag to keep out air.

The encoder's pulse count method should be designed with taking operating speed, sampling time, and the design of the microcomputer software, etc. into consideration.

The item designed mainly corresponds to JIS (Japanese Industrial Standards) on the reliability conditions.

4. This product does not yet conform to Halogen Free regulation generally required.

Information of Chemical Substances and Environmental Hazardous Substances.

This product has not been manufactured with ozone depleting chemical controlled under the Montreal Protocol.

This product complies with the RoHS Directive Restriction of the use of certain Hazardous Substance in electrical and electronic equipment DIRECTIVE 2011/65/EU).

All the materials used in the part are registered material under the Law Concerning the Examination and Regulation of Manufacture etc. or Chemical Substances.

Soldering conditions :

Perform the soldering under the conditions shown below.

Temperature profile of reflow soldering. (Fig-6)

Soldering conditions (1)

<Reflow soldering>

• Solder clean thickness : 1=0.15 mm - 0.2 mm

• Soldering condition (1)

<Reflow soldering> Fig-6
(Temperature profile of reflow soldering)

• Prohibitive items :

You should not use preflux.

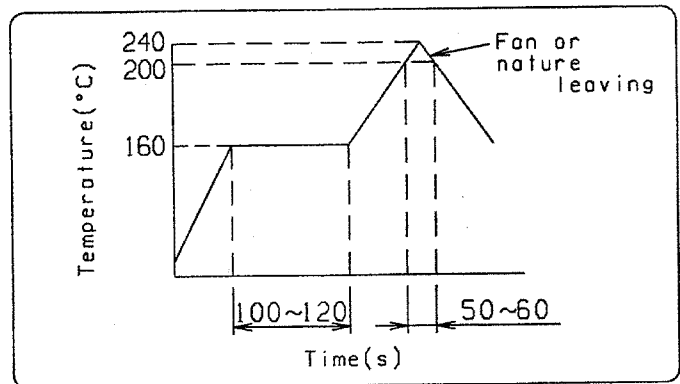

Soldering conditions (2)

<Soldering iron>

Soldering iron : 20W or lower.

Temperature at the iron tip : 350°C or lower.

The duration to apply the soldering iron : 3 seconds or lower. (1 time)

PWB design - When you design mounting hole of PWB, please refer to its dimension defined in this specification.

Particularly, care should be taken in the case of wiring such as jumper wire near the product body where flux is delating.

If flux is spattered to the product body,

it may cause electrical contact or sliding trouble.

NAME	11mm GS ENCODER	ISSUE	REVISIONS	DATE
		TYPE NO.	EVE SBB FE5 16B	DRAWING NO.

Packing:

- (1) Package style : Card bord box.(300pcs./pack)
- (2) Package size : W:160 X L:260 X H:110
- (3) Tray style : Plastic tray.(50pcs./tray)
- (4) Tray size : W:150 X L:248 X H:25

Carton Box Size

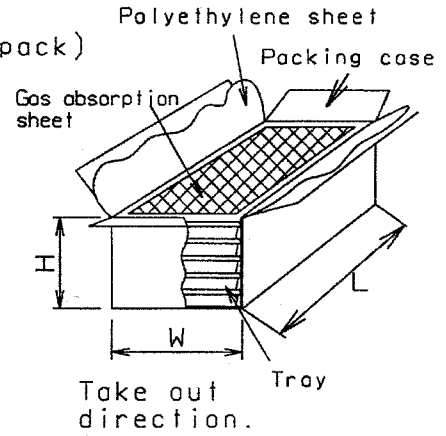

Tray A

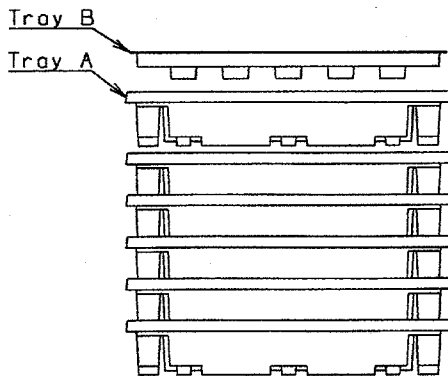
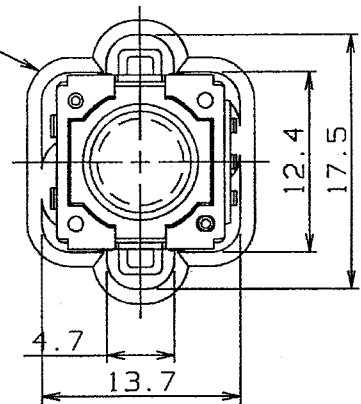
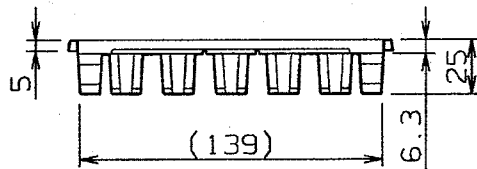
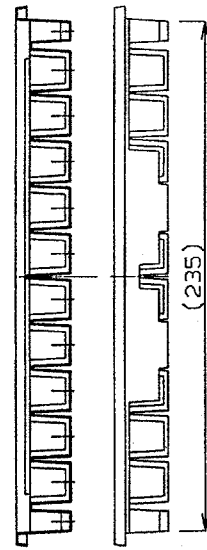
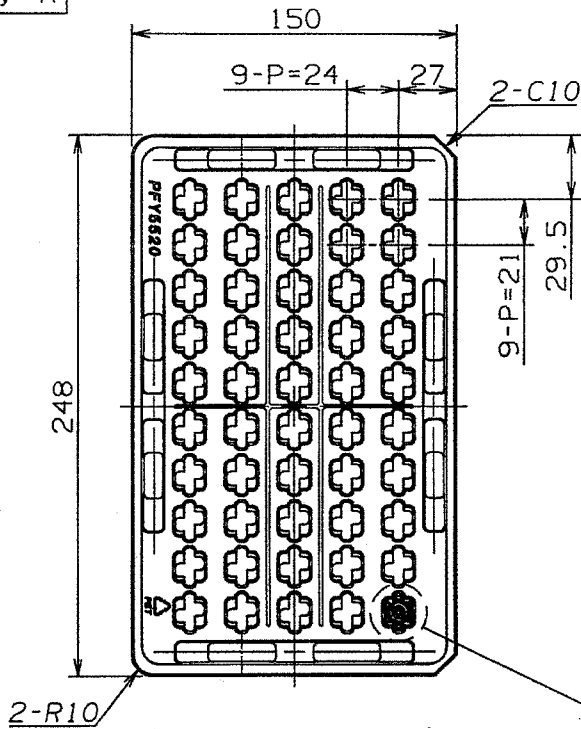

Tray (Pair)
6 pcs.

NAME	11mm GS ENCODER	ISSUE	REVISIONS	DATE
		TYPE NO.	EVE SBB FE5 16B	DRAWING NO.

REVISION'S CAREER SHEET

ISSUE	REVISIONS	DATE	DESIGN	CHECK	APPROVAL
/	New drawing.	/	/	/	/

NAME 11mm GS ENCODER		
TYPE NO. EVE SBB FES 16B	ISSUE	REVISIONS 8/8
	DRAWING NO. RV-H- 1781	DATE