

LOC	DIST	REVISIONS					
		P	LTN	DESCRIPTION	DATE	DWN	APVD
GP	00	A		RELEASED	23MAR2014	RT	NS
		B		REVISED PER ECO-14-010320	07JUL2014	LAW	NS
		C		REVISED PER ECO-17-006848	10MAY2017	JM	SS

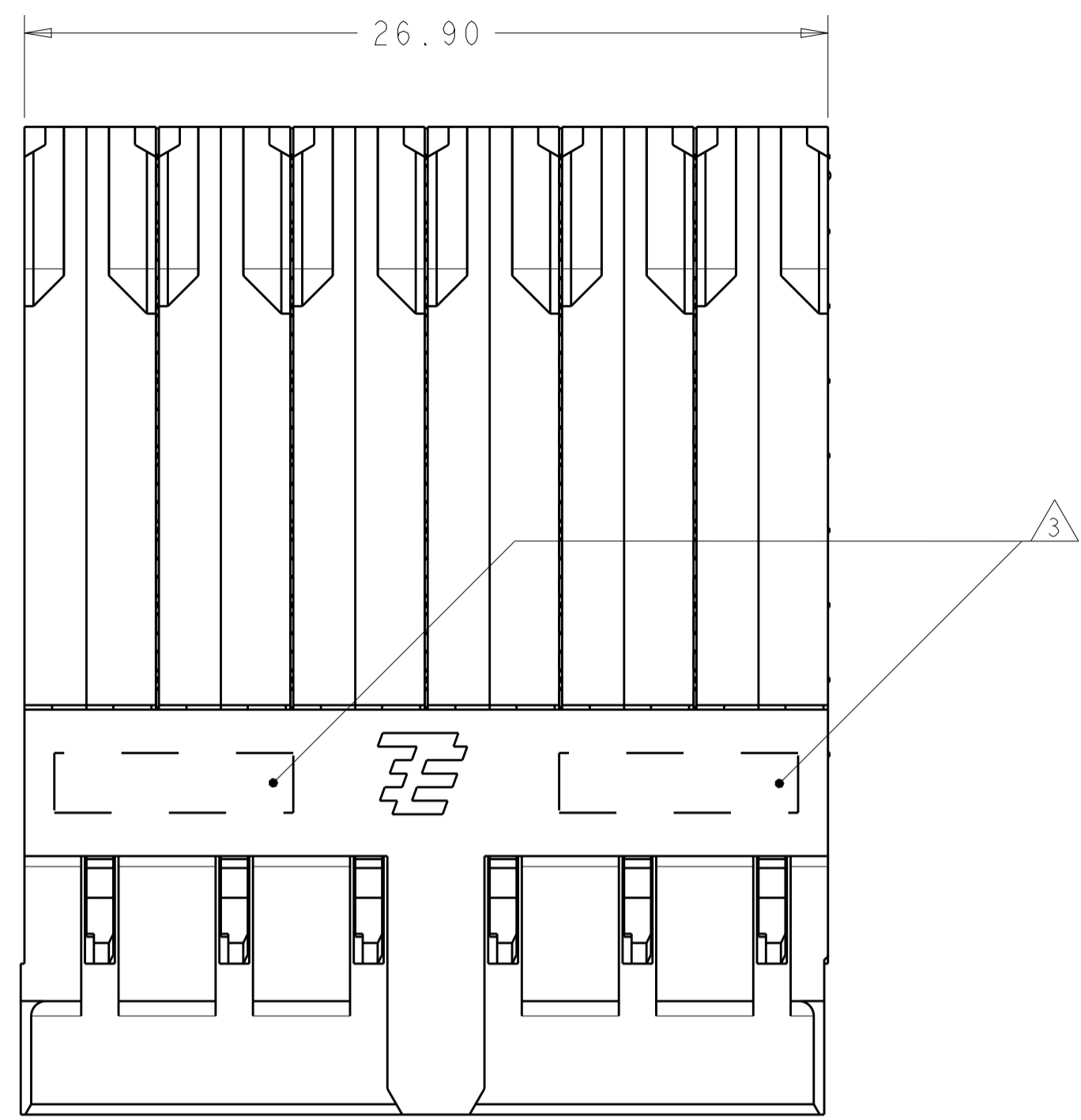

- 1 MATERIAL:
CONTACT AND SHIELD - COPPER ALLOY.
HOUSINGS, AND ORGANIZER - THERMOPLASTIC, UL 94V-0, BLACK.
- 2 CONFORMS TO REQUIREMENTS OF TE PRODUCT SPECIFICATION 108-2413 & 108-32037
BASED ON TELCORDIA GR-1217-CORE FOR SYSTEM QUALITY LEVEL III;
APPLICATIONS IN CONTROLLED ENVIRONMENTS (CENTRAL OFFICE).
- 3 CONNECTOR MARKED WITH PART NUMBER, DATE CODE,
MANUFACTURING LOCATION IDENTIFICATION CODE, AND 2D BARCODE IN APPROXIMATE AREA SHOWN.
- 4 CONTACT AREA LUBRICATED WITH BELLCORE APPROVED LUBRICANT.
TECHNICAL REFERENCE: GR-1217-CORE, ISSUE 2, DECEMBER 2008.
- 5 PLATED THRU HOLE REQUIREMENTS:
FINISHED HOLE = $\varnothing 0.344 \pm 0.039$
DRILLED HOLE = $\varnothing 0.420 \pm 0.013$
COPPER THICKNESS = 0.038 ± 0.013
IMMERSION TIN IF APPLICABLE = 0.00051 ± 0.00013
- 6 PLATED THRU HOLE REQUIREMENTS:
FINISHED HOLE = $\varnothing 0.244 \pm 0.039$
DRILLED HOLE = $\varnothing 0.320 \pm 0.013$
COPPER THICKNESS = 0.038 ± 0.013
IMMERSION TIN IF APPLICABLE = 0.00051 ± 0.00013
- 7 PTH DIMENSIONS APPLY TO 1.00mm DEPTH FROM MOUNT SIDE OF PCB.
- 8 HOLE POSITION TOLERANCE APPLIES WITHIN PATTERN FOR CONNECTOR
PATTERN TO CONNECTOR PATTERN, A 0.12 \varnothing POSITION TOLERANCE APPLIES.

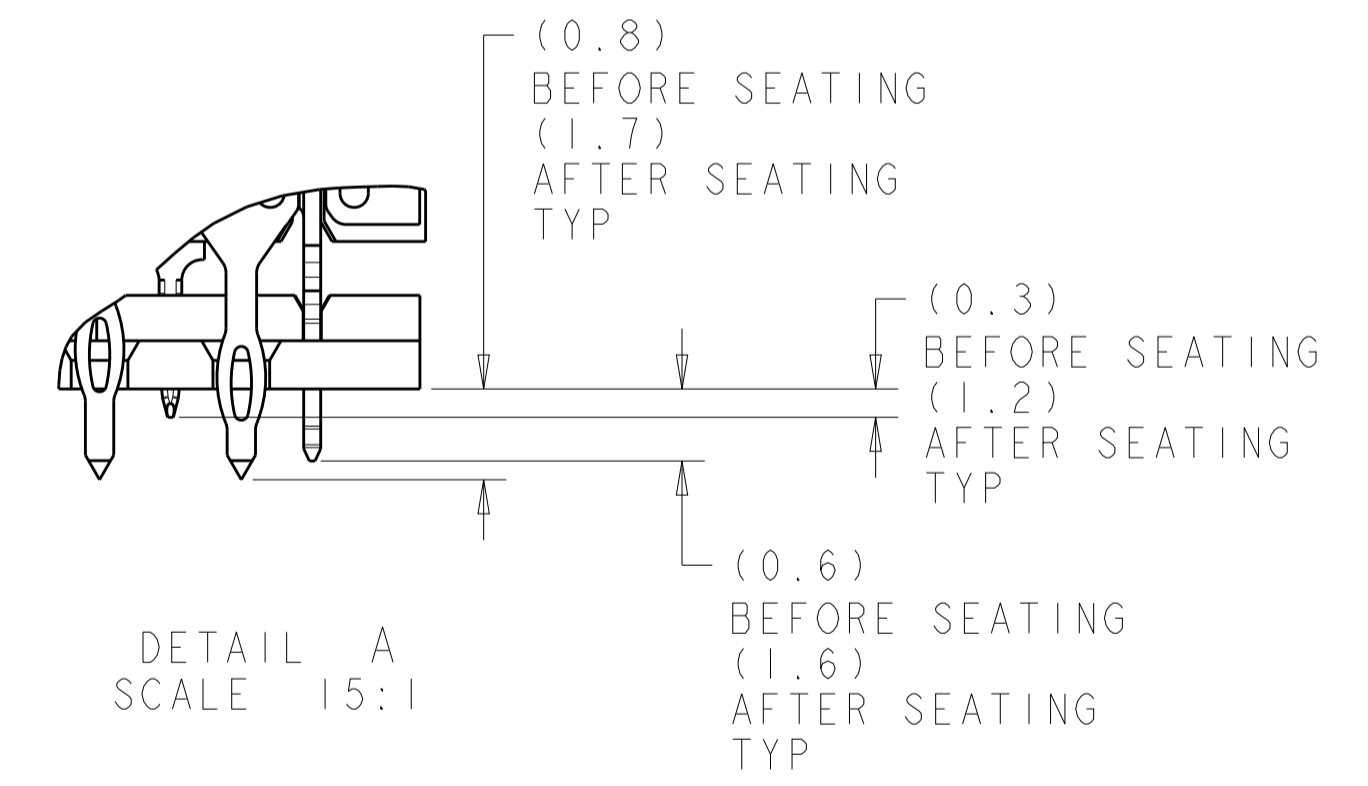
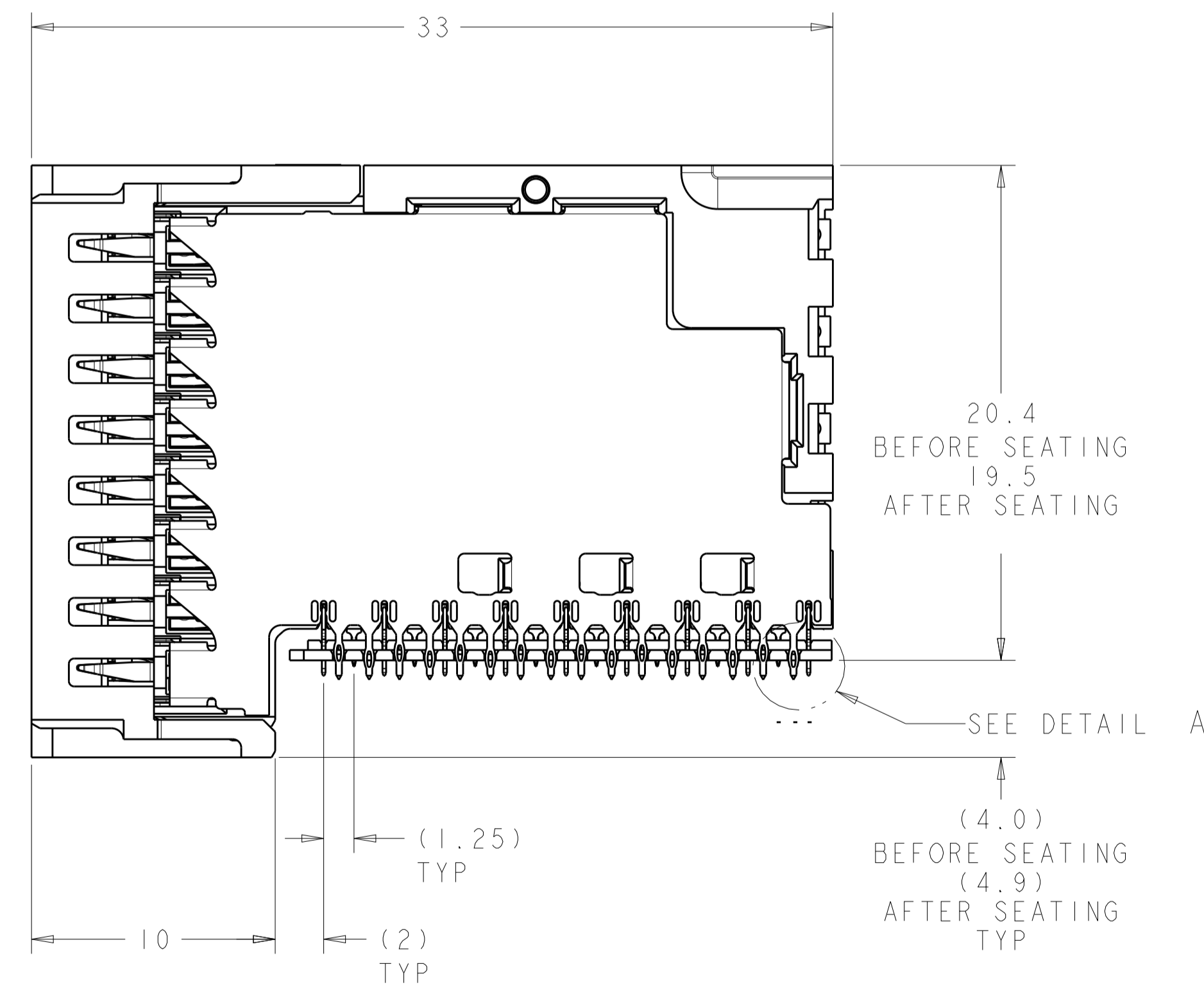
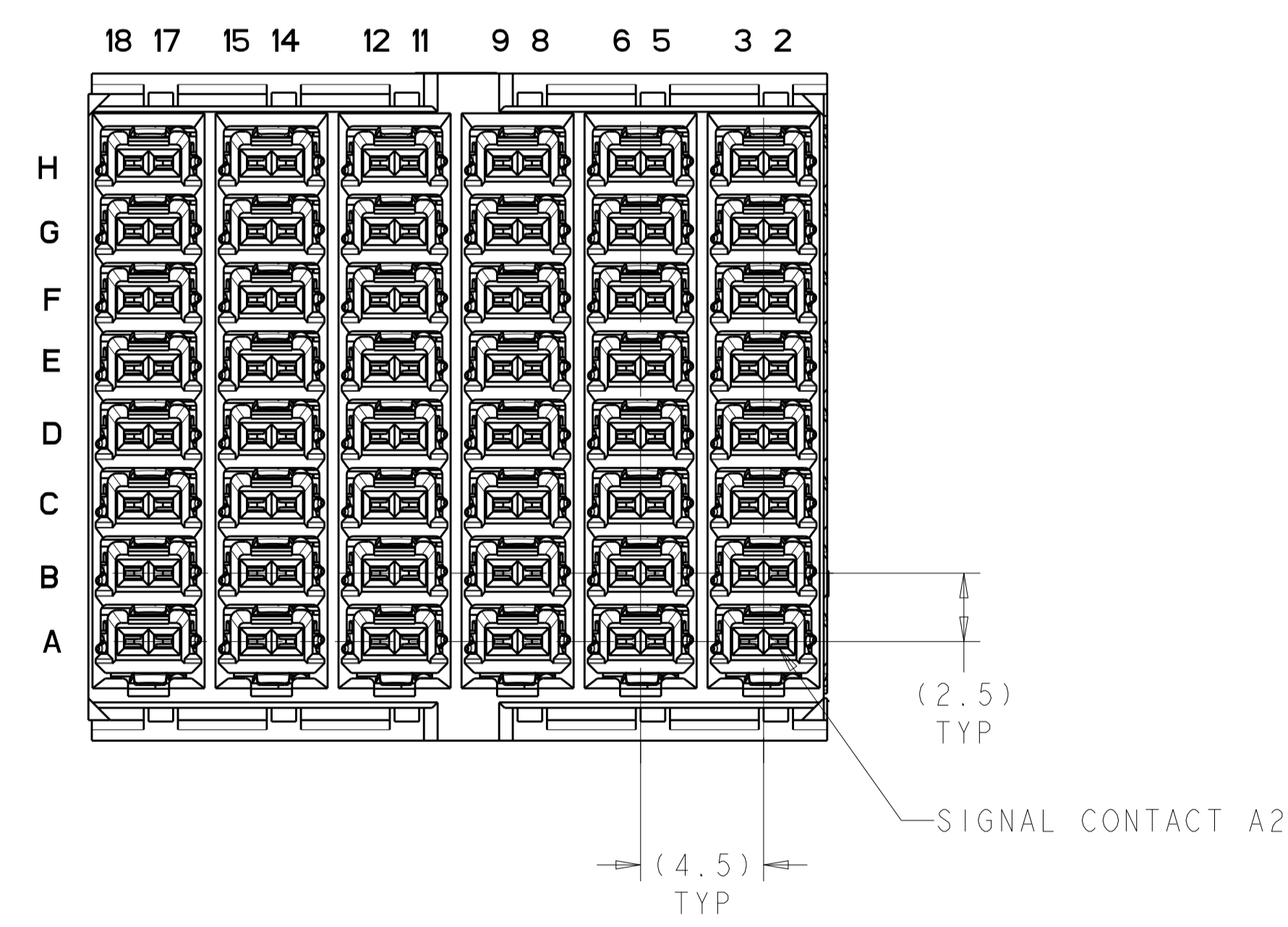

TIN	2198263-3
OBSOLETE TIN LEAD	2198263-1
PRESS FIT TAIL PLATING	PART NO

THIS DRAWING IS A CONTROLLED DOCUMENT.		DWN: R. THOMPSON 29NOV2011	TE Connectivity	
DIMENSIONS: mm		CHK: N. SWANGER 29NOV2011		
TOLERANCES UNLESS OTHERWISE SPECIFIED:		APVD: N. SWANGER 29NOV2011		
0 PLC	± 0.2	PRODUCT SPEC	NAME: RECEPTACLE ASSEMBLY, 8 PAIR 6 COLUMN, RIGHT ANGLE, 4.5mm PITCH, STRADA WHISPER 360	
1 PLC	± 0.2	APPLICATION SPEC	SIZE: 114-13301	
2 PLC	± 0.08	FINISH	WEIGHT: -	
3 PLC	± 0.013	SEE TABLE	Customer Drawing	
4 PLC	± 0.013		SCALE: 5:1 SHEET 1 OF 2 REV C	
ANGLES	\pm			
MATERIAL				

LOC	DIST	REV	DATE	BY	APPV
GP	00				

FOOTPRINT SHOWN IS FOR SINGLE MODULE APPLICATION. WHEN CONNECTORS ARE STACKED SIDE BY SIDE, THESE SI VIAS ARE USED AS GROUNDS BY THE NEXT CONNECTOR

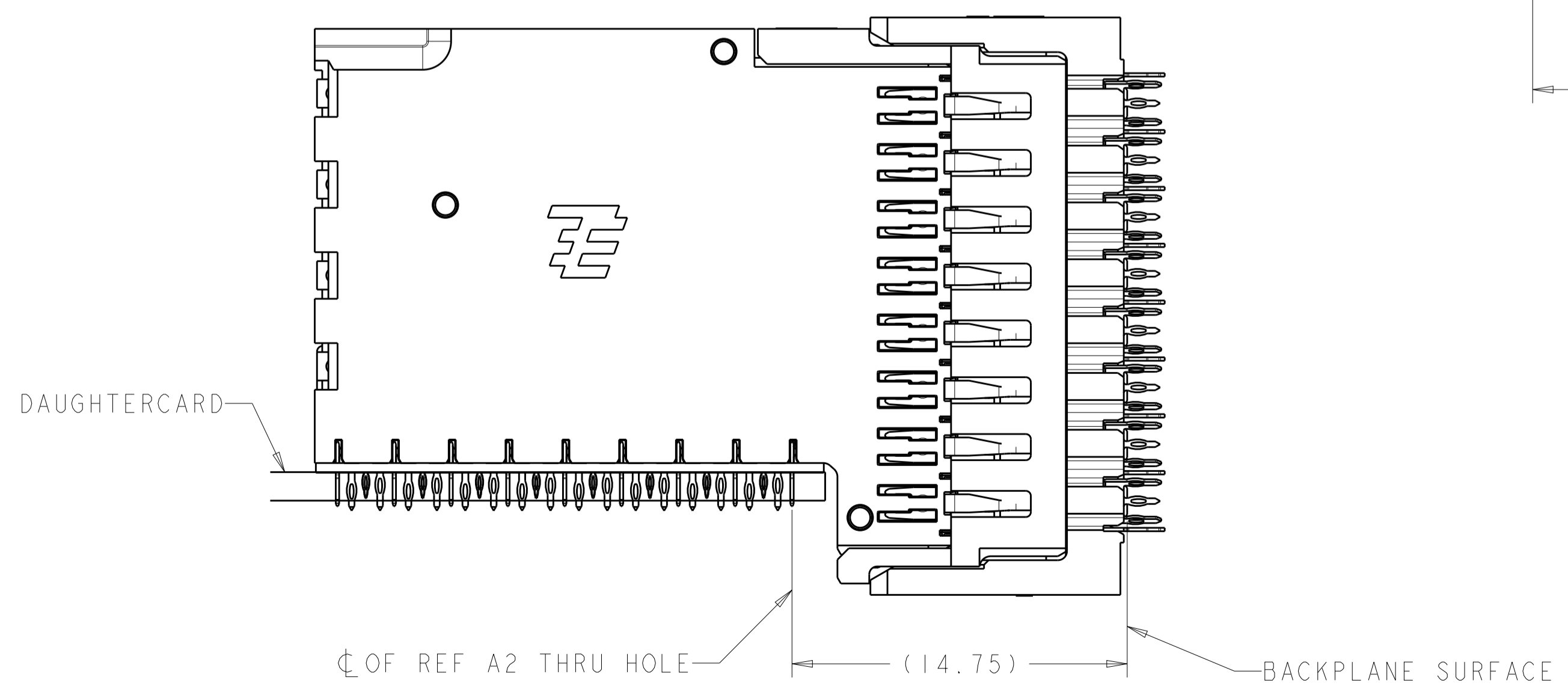
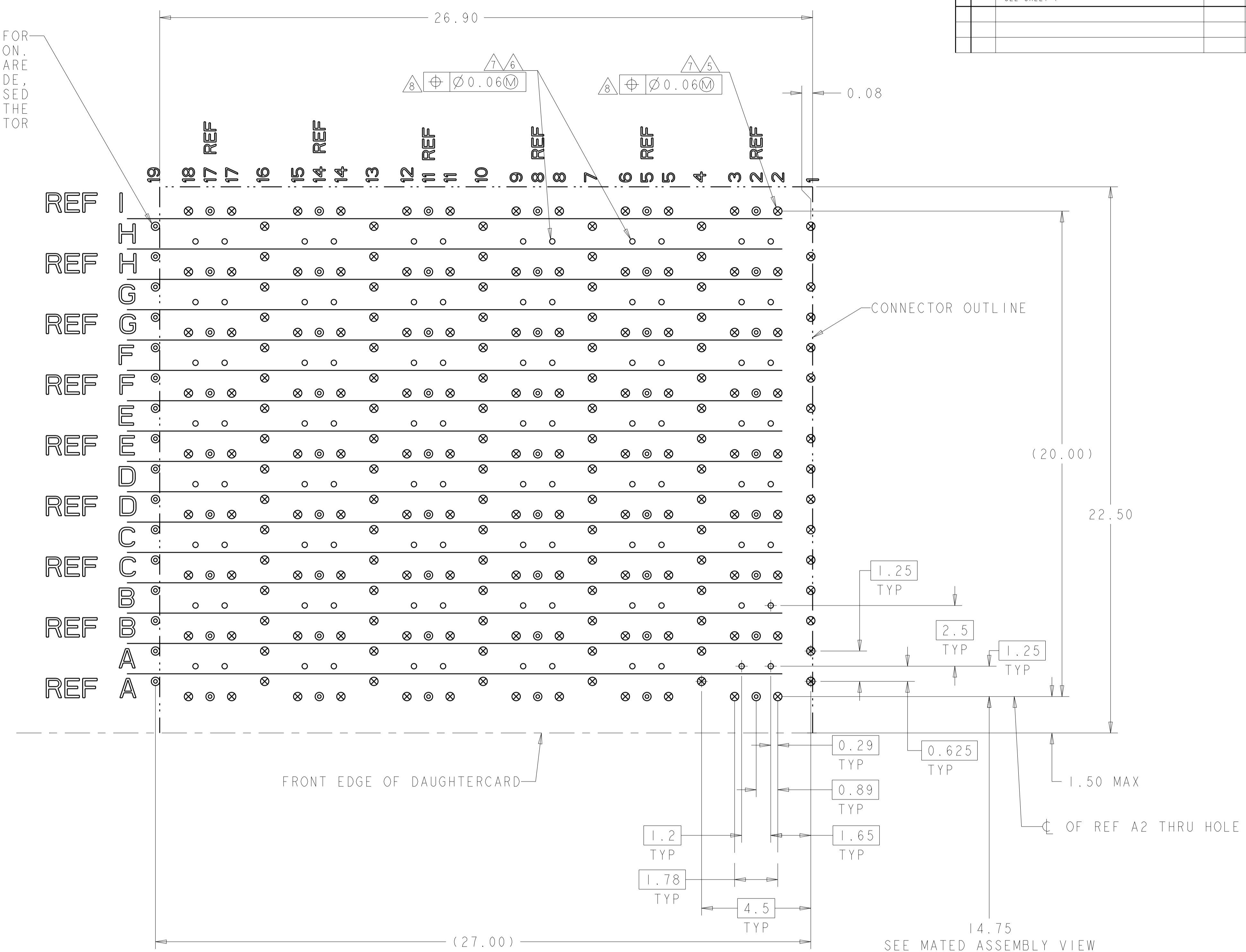

PCB LAYOUT COMPONENT SIDE SHOWN SCALE 10:1

- = SIGNAL
- ⊗ = GROUND
- ⊙ = SIGNAL INTEGRITY VIA TO GROUND

THIS DRAWING IS A CONTROLLED DOCUMENT.		OWN R. THOMPSON 29NOV2011	TE Connectivity
DIMENSIONS:		CHK N. SWANGER 29NOV2011	
TOLERANCES UNLESS OTHERWISE SPECIFIED:		APVD N. SWANGER 29NOV2011	NAME RECEPTACLE ASSEMBLY, 8 PAIR 6 COLUMN, RIGHT ANGLE, 4.5mm PITCH, STRADA WHISPER 360
mm		PRODUCT SPEC	SIZE A100779C=2198263
		APPLICATION SPEC	RESTRICTED TO
MATERIAL		WEIGHT	SCALE 5:1 SHEET 2 OF 2 REV C
FINISH		Customer Drawing	