

Low-Noise, Regulated, -2V GaAsFET Bias

General Description

The MAX840/MAX843/MAX844 low-noise, inverting charge-pump power supplies are ideal for biasing GaAsFETs in cellular telephone transmitter amplifiers. They operate with inputs down to 2.5V.

The MAX840 offers both a -2V preset output and a -0.5V to -9.4V adjustable output. The MAX843/MAX844 use an external positive control voltage to set the negative output voltage. Input voltage range for all the devices is 2.5V to 10V, and output current is 4mA with $V_{IN} > 2.7V$. These circuits can operate with small capacitors, as low as 0.22 μ F.

An internal linear regulator reduces the MAX840's output voltage ripple to 1mVp-p. With a well-filtered control voltage (V_{CTRL}), the MAX843/MAX844 also achieve less than 1mVp-p typical output ripple. Supply current is 750 μ A, and reduces to less than 1 μ A in shutdown (MAX840/MAX843). The MAX844's unregulated output is active in shutdown, with the charge pump switching at 20kHz. It provides a low-power LCD supply.

Applications

Cellular Phones
GaAsFET Power Amplifier Modules
Personal Communicators, PDAs
Wireless Data Loggers
Continuously Adjustable GaAsFET Bias
LCD-Bias Contrast Control
Regulated Negative Power Supplies

Typical Operating Circuit

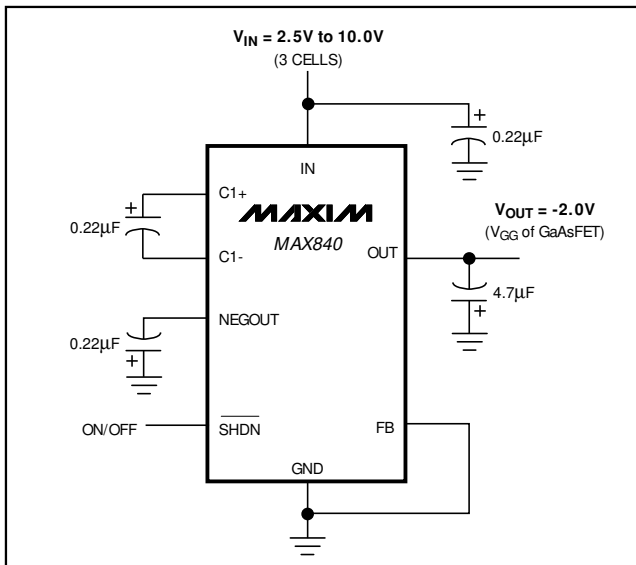

Features

- ♦ Fixed -2V or Adjustable -0.5V to -9.4V Output at 4mA (MAX840)
- ♦ 2.5V to 10V Input Voltage Range
- ♦ Operate with Small Capacitors (as low as 0.22 μ F)
- ♦ 1mVp-p Output Voltage Ripple
- ♦ Charge-Pump Switching Frequency:
 - 100kHz in Normal Operation
 - 20kHz in Shutdown Mode (MAX844)
- ♦ 1 μ A Max Logic-Level Shutdown Over Temp. (MAX840/MAX843)
- ♦ Small 8-Pin SO Package

Ordering Information

PART	TEMP. RANGE	PIN-PACKAGE
MAX840C/D	0°C to +70°C	Dice*
MAX840ISA	-25°C to +85°C	8 SO
MAX840ESA	-40°C to +85°C	8 SO
MAX843C/D	0°C to +70°C	Dice*
MAX843ISA	-25°C to +85°C	8 SO
MAX843ESA	-40°C to +85°C	8 SO
MAX844C/D	0°C to +70°C	Dice*
MAX844ISA	-25°C to +85°C	8 SO
MAX844ESA	-40°C to +85°C	8 SO

* Dice are specified at $T_A = +25^\circ\text{C}$ only.

Pin Configuration

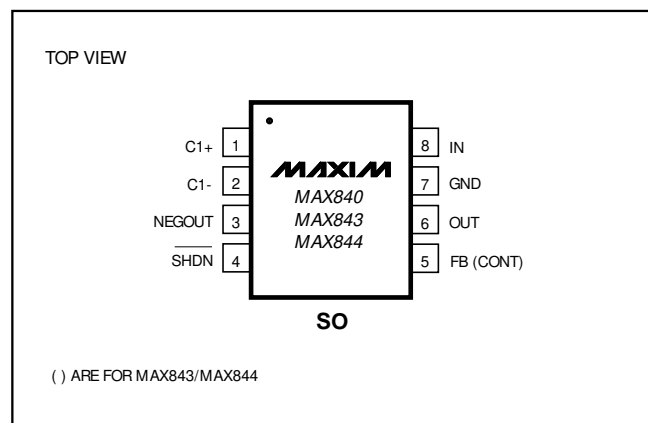

Low-Noise, Regulated, -2V GaAsFET Bias

ABSOLUTE MAXIMUM RATINGS

Supply Voltage, V_{IN} to GND-0.3V to 10.5V
 V_{NEGOUT} to GND-10.5V to 0.3V
 V_{IN} to V_{NEGOUT}-0.3V to 21V
 V_{OUT} to GND (Note 1)..... V_{NEGOUT} to 0.3V
 $V_{\overline{SHDN}}$ to GND-0.3V to ($V_{IN} + 0.3V$)
 Continuous Power Dissipation ($T_A = +70^\circ\text{C}$)
 SO (derate 5.88mW/ $^\circ\text{C}$ above $+70^\circ\text{C}$)471mW

Operating Temperature Ranges
 MAX84_I_A-25 $^\circ\text{C}$ to +85 $^\circ\text{C}$
 MAX84_E_A-40 $^\circ\text{C}$ to +85 $^\circ\text{C}$
 Storage Temperature Range-65 $^\circ\text{C}$ to +150 $^\circ\text{C}$
 Lead Temperature (soldering, 10sec)+300 $^\circ\text{C}$

Note 1: The output may be shorted to NEGOUT or GND if the package power dissipation is not exceeded. Typical short-circuit current from 4V to GND is 40mA.

Stresses beyond those listed under "Absolute Maximum Ratings" may cause permanent damage to the device. These are stress ratings only, and functional operation of the device at these or any other conditions beyond those indicated in the operational sections of the specifications is not implied. Exposure to absolute maximum rating conditions for extended periods may affect device reliability.

ELECTRICAL CHARACTERISTICS

(Figures 2a and 2c, $2.5V \leq V_{IN} \leq 10V$, $V_{OUT} = -2V$, $GND = 0V$, $R_L = \infty$, $\overline{SHDN} = V_{IN}$, $T_A = T_{MIN}$ to T_{MAX} , unless otherwise noted. Typical values are measured at $V_{IN} = 3.6V$ and $T_A = +25^\circ\text{C}$.)

PARAMETER	SYMBOL	CONDITIONS	MIN	TYP	MAX	UNITS	
Supply Voltage Range	V_{IN}		2.5		10	V	
Output Voltage	V_{OUT}	MAX840, $V_{FB} = 0V$	$V_{IN} \geq 2.5V$, $I_{OUT} = 0mA$ to 3mA	-2.1	-2.0	-1.9	V
			$V_{IN} \geq 2.7V$, $I_{OUT} = 0mA$ to 4mA	-2.1	-2.0	-1.9	
		MAX843/MAX844, $V_{CTRL} = 2V$	$V_{IN} \geq 2.5V$, $I_{OUT} = 0mA$ to 3mA	-2.05	-2.0	-1.95	
			$V_{IN} \geq 2.7V$, $I_{OUT} = 0mA$ to 4mA	-2.05	-2.0	-1.95	
Output Voltage Adjust Range	V_{OUT}			-0.5 to ($V_{IN} - 0.6$)		V	
FB Voltage	V_{FB}	MAX840, no load	-0.516	-0.5	-0.484	V	
FB Leakage Current	I_{FB}	MAX840, $V_{FB} = -0.5V$		± 1	± 100	nA	
CONT Leakage Current	I_{CONT}	MAX843/MAX844, $V_{CONT} = 0V$		± 1	± 100	nA	
Supply Current	I_Q	No load, $V_{IN} \leq 3.6V$		750	1300	μA	
Shutdown Supply Current	I_{SHUT}	MAX840/MAX843, $V_{IN} = 10V$, $\overline{SHDN} = 0V$			1	μA	
		MAX844, $V_{IN} = 10V$, $\overline{SHDN} = 0V$		940			
		MAX844, $V_{IN} \leq 3.6V$, $\overline{SHDN} = 0V$		175	300		
V_{OUT} Load Regulation		$V_{IN} = 3.6V$, $R_L = \infty$ or 500 Ω	MAX840, $V_{FB} = 0V$		3	8	mV/mA
			MAX843/MAX844, $V_{CTRL} = 2V$		2	8	
V_{OUT} Ripple		$C_4 = 10\mu\text{F}$		1		mVp-p	
Oscillator Frequency	F_{OSC}	$V_{IN} = 3.6V$, $T_A = +25^\circ\text{C}$	MAX840/MAX843/ MAX844	80	100	120	kHz
			MAX844, $\overline{SHDN} = 0V$	14	20	26	
Input High Voltage	V_{IH}	\overline{SHDN}	2.2			V	
Input Low Voltage	V_{IL}	\overline{SHDN}			0.35	V	
Input Current	I_{IN}	\overline{SHDN}	-1		1	μA	
Input Capacitance	C_{IN}	\overline{SHDN}		10		pF	

Low-Noise, Regulated, -2V GaAsFET Bias

Typical Operating Characteristics

(Circuit of Figure 2a, $V_{IN} = 3.6V$, $T_A = +25^\circ C$, unless otherwise noted.)

MAX840/MAX843/MAX844

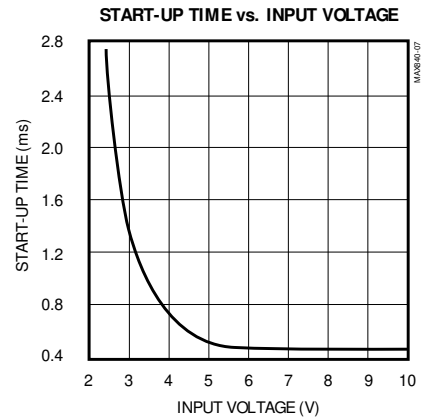
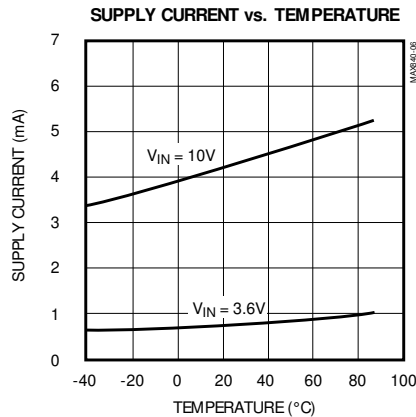
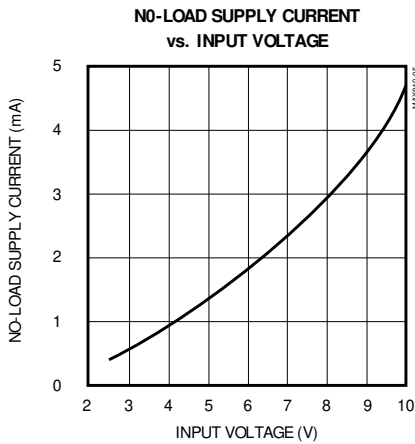
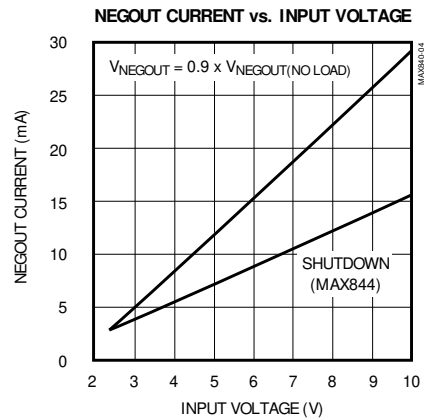
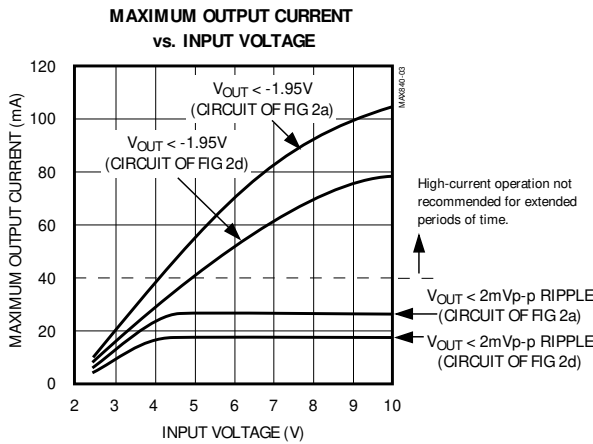
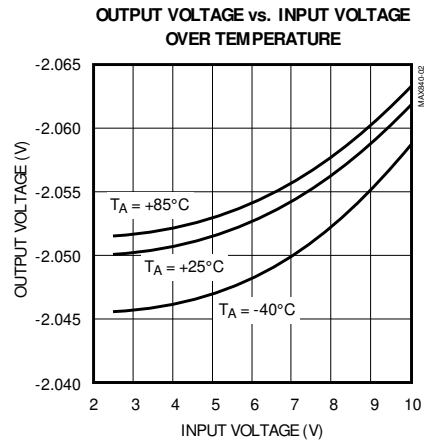
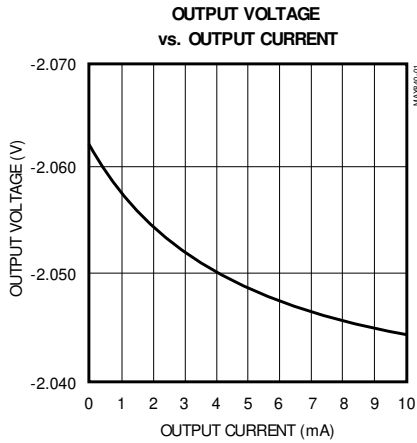

Low-Noise, Regulated, -2V GaAsFET Bias

Typical Operating Characteristics (continued)

(Circuit of Figure 2a, $V_{IN} = 3.6V$, $T_A = +25^\circ C$, unless otherwise noted.)

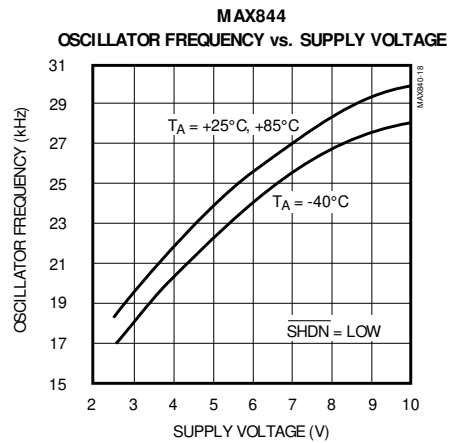
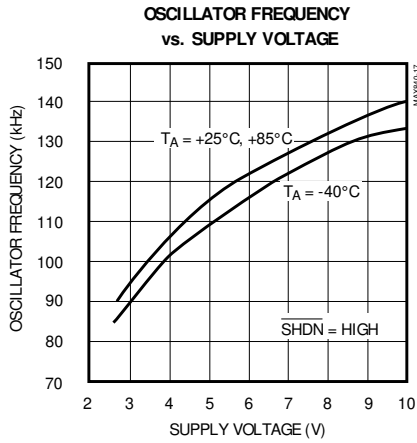

MAX840 OUTPUT NOISE AND RIPPLE
($C_1 = C_2 = C_3 = 1\mu F$, $C_4 = 10\mu F$)

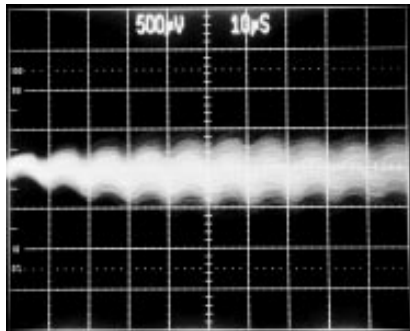

$10\mu s/div$
 $V_{IN} = 3.6V$, $V_{OUT} = -2V$, $I_{OUT} = 4mA$, AC COUPLED

MAX840 OUTPUT NOISE AND RIPPLE
($C_1 = C_2 = C_3 = 0.22\mu F$, $C_4 = 4.7\mu F$)

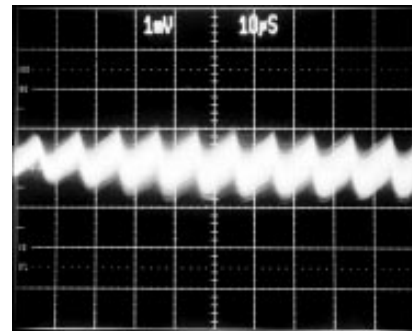

$10\mu s/div$
 $V_{IN} = 3.6V$, $V_{OUT} = -2V$, $I_{OUT} = 4mA$, AC COUPLED

MAX843/MAX844 OUTPUT NOISE AND RIPPLE
($C_1 = C_2 = C_3 = 1\mu F$, $C_4 = 10\mu F$)

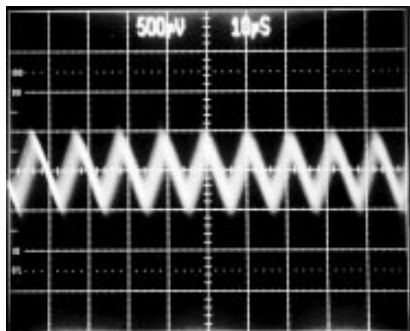

$10\mu s/div$
 $V_{IN} = 3.6V$, $V_{OUT} = -2V$, $I_{OUT} = 4mA$, AC COUPLED

MAX843/MAX844 OUTPUT NOISE AND RIPPLE
($C_1 = C_2 = C_3 = 0.22\mu F$, $C_4 = 4.7\mu F$)

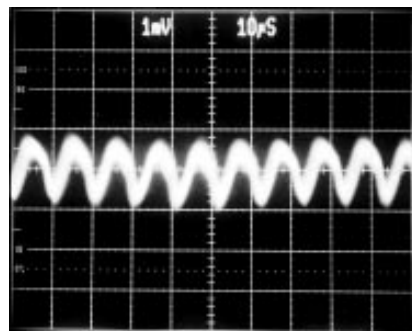

$10\mu s/div$
 $V_{IN} = 3.6V$, $V_{OUT} = -2V$, $I_{OUT} = 4mA$, AC COUPLED

Low-Noise, Regulated, -2V GaAsFET Bias

Typical Operating Characteristics (continued)

(Circuit of Figure 2a, $V_{IN} = 3.6V$, $T_A = +25^\circ C$, unless otherwise noted.)

MAX840/MAX843/MAX844

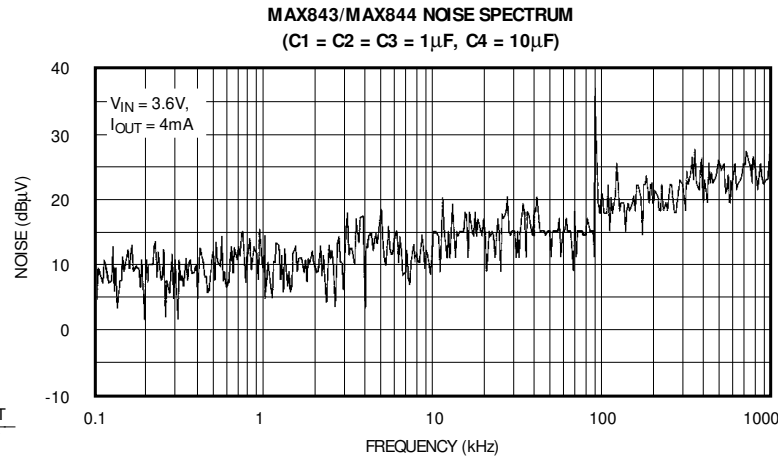
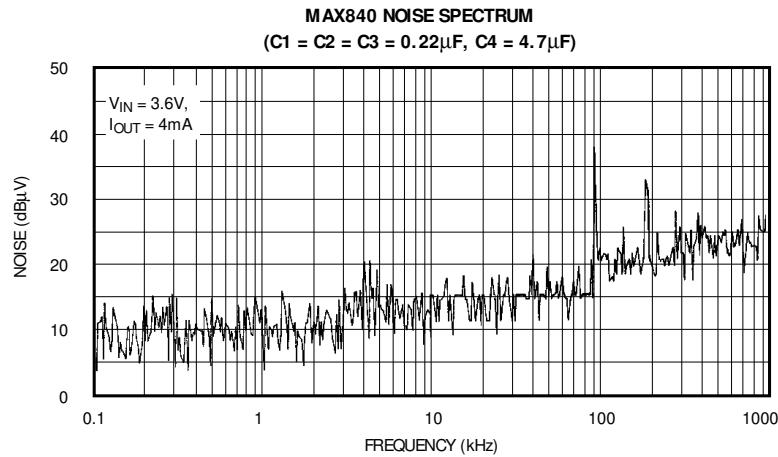
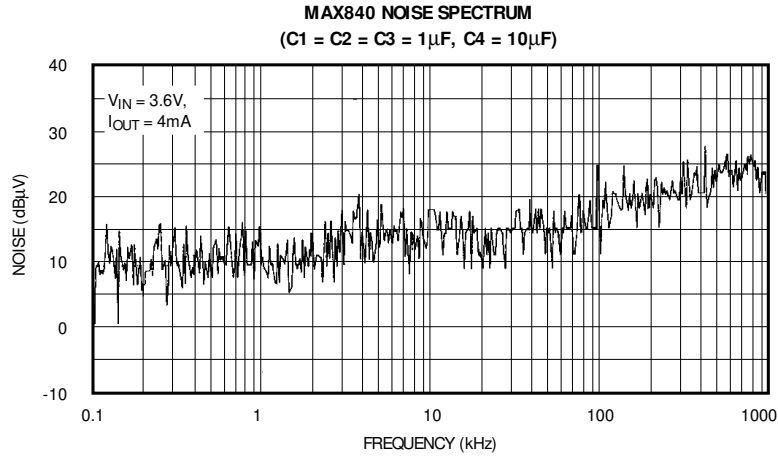

NOTE: $dB\mu V = 20 \text{ LOG } \frac{V_{OUT}}{1\mu V}$

Low-Noise, Regulated, -2V GaAsFET Bias

Typical Operating Characteristics (continued)

(Circuit of Figure 2a, $V_{IN} = 3.6V$, $T_A = +25^\circ C$, unless otherwise noted.)

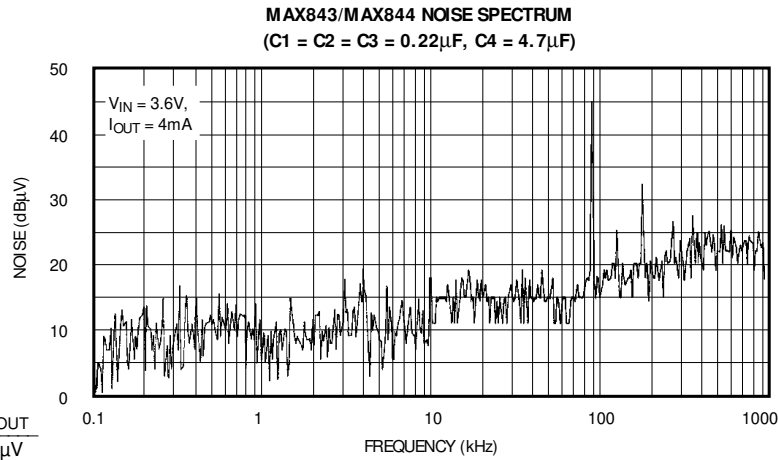

START-UP FROM SHUTDOWN

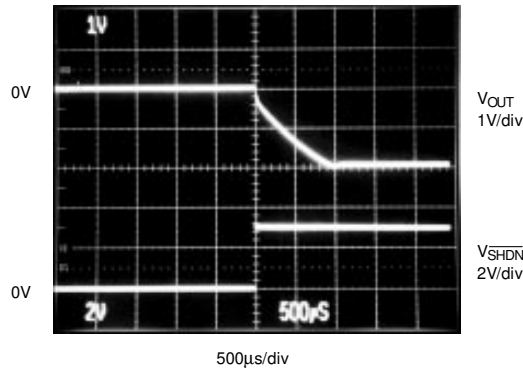

LOAD-TRANSIENT RESPONSE

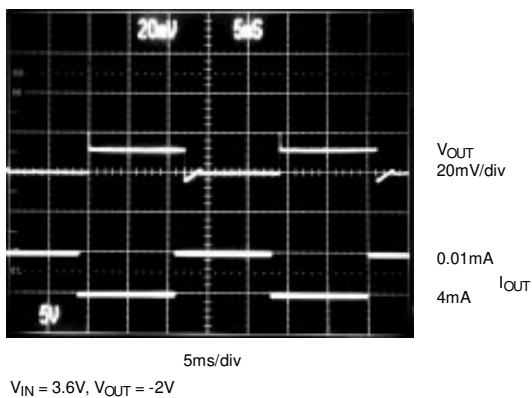

LINE-TRANSIENT RESPONSE

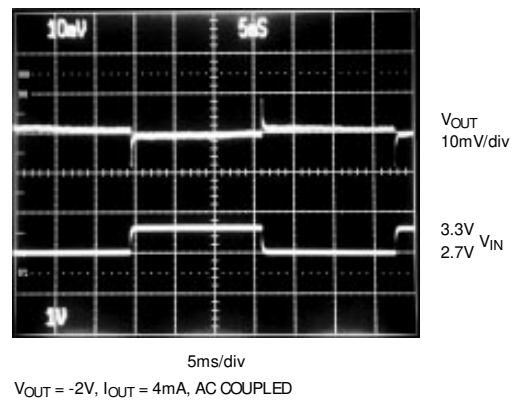

Low-Noise, Regulated, -2V GaAsFET Bias

Pin Description

MAX840/MAX843/MAX844

PIN		NAME	FUNCTION
MAX840	MAX843 MAX844		
1	1	C1+	Positive Terminal for C1
2	2	C1-	Negative Terminal for C1
3	3	NEGOUT	Negative Output Voltage (unregulated)
4	4	$\overline{\text{SHDN}}$	Active-Low, TTL Logic-Level Shutdown Input
5	—	FB	Dual Mode™ Feedback Input. When FB is grounded, the output is preset to -2V. To select other output voltages, connect FB to an external resistor divider (Figure 2b).
—	5	CONT	Control Voltage Input. To set V_{OUT} , connect a resistor divider between OUT and a positive control voltage between 0V and 10V (Figure 2c).
6	6	OUT	Regulated Negative Output Voltage
7	7	GND	Ground
8	8	IN	Positive Power-Supply Input

Dual Mode is a trademark of Maxim Integrated Products.

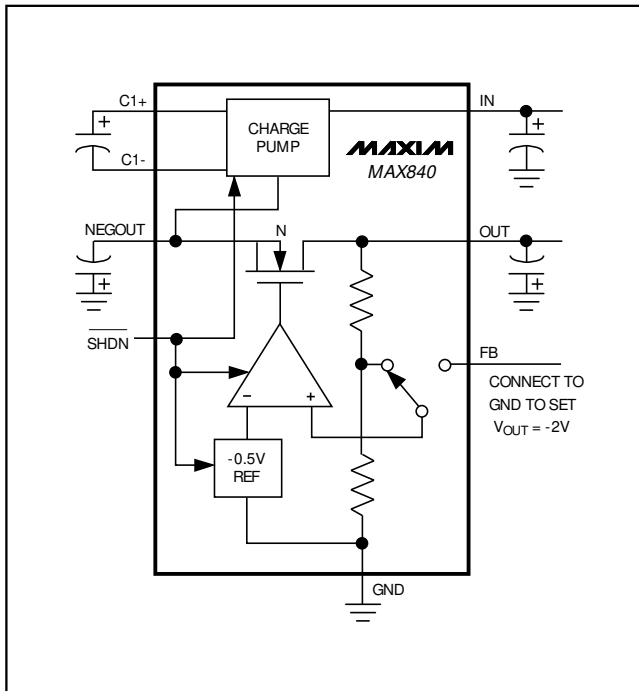

Figure 1a. MAX840 Block Diagram

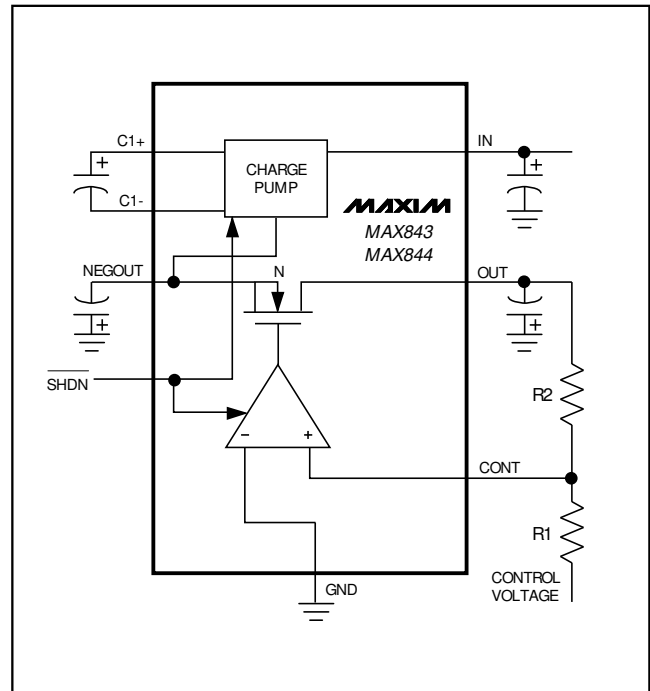

Figure 1b. MAX843/MAX844 Block Diagram

Low-Noise, Regulated, -2V GaAsFET Bias

Detailed Description

The MAX840/MAX843/MAX844 are low-noise, inverting, regulated charge-pump power supplies designed for biasing GaAsFET devices, such as power-amplifier modules in cellular handsets.

The applied input voltage (V_{IN}) is first inverted to a negative voltage at NEGOUT by a capacitive charge pump. This voltage is then regulated by an internal low-noise linear regulator, and appears at OUT (Figure 1). The minimum (most negative) output voltage achievable is the inverted positive voltage, plus the 0.6V required by the post-regulator. For the MAX840, the linear regulator reduces ripple noise induced by the charge-pump inverter to 1mVp-p at V_{OUT} . In addition, the linear regulator's excellent AC rejection attenuates noise from the incoming supply.

Applications Information

Setting the Output Voltage

For the MAX840, select either a fixed or adjustable output voltage. Connect FB directly to GND for a fixed -2V output (Figure 2a). Select an alternate output voltage by connecting FB to the midpoint of a resistor voltage divider from OUT to GND (Figure 2b). V_{IN} must be 0.6V above the absolute value of V_{OUT} to allow proper regulation. The output voltage is calculated from the formula below. Choose R_2 to be between 100k Ω and 400k Ω .

$$V_{OUT} = (-0.5V)(1 + R_2 / R_1)$$

For the MAX843/MAX844, set the output voltage by connecting a resistor voltage divider between OUT and a positive control voltage (V_{CTRL}) (Figure 2c).

$$V_{OUT} = -V_{CTRL} (R_2 / R_1)$$

Shutdown Mode

The MAX840/MAX843/MAX844 feature a shutdown mode that reduces the supply current to 1 μ A max over temperature (300 μ A max for the MAX844). When the MAX840/MAX843 are in shutdown, the outputs (OUT, NEGOUT) and the charge-pump oscillator are disabled. When the MAX844 is in shutdown, only the linear regulator is disabled and the NEGOUT output remains enabled. However, the charge-pump oscillation frequency is reduced to 20kHz, reducing the available power at NEGOUT. The output voltage at NEGOUT can be used to bias an LCD while in shutdown.

Capacitors

Use capacitors with low effective series resistance (ESR) to maintain a low dropout voltage ($V_{IN} - |V_{OUT}|$). The overall dropout voltage is a function of the charge pump's output resistance and the voltage drop across the linear regulator (N-channel pass transistor). At the 100kHz switching frequency, the charge-pump output resistance is a function of C_1 and C_2 's ESR. Therefore, minimizing the ESR of the charge-pump capacitors minimizes the dropout voltage.

The output resistance of the entire circuit is approximately:

$$R_{OUT} = R_O + 4 \times ESR_{C1} + ESR_{C4} + \frac{1}{f_S \times C_1} + R_{(linear\ regulator)}$$

where [$R_O + R_{(linear\ regulator)}$], the effective resistance of the internal switches and the resistance across the linear regulator, is approximately 71 Ω at $V_{IN} = 2.5V$, 48 Ω at $V_{IN} = 5V$, and 40 Ω at $V_{IN} = 10V$.

C_1 , C_2 , and C_3 should be 1 μ F capacitors with less than 0.8 Ω ESR. C_4 should be a 10 μ F capacitor with less than 0.2 Ω ESR. Smaller capacitor values can be used ($C_1 = C_2 = C_3 = 0.22\mu F$, $C_4 = 4.7\mu F$) with a small increase in output noise and ripple (Figure 2d). All capacitors should be either surface-mount chip tantalum or ceramic types. External capacitor values can be adjusted to optimize size and cost.

Layout and Grounding

Good layout is important, primarily for good noise performance. Take the following steps to ensure good layout:

- 1) Mount all components as close together as possible.
- 2) Keep traces short to minimize parasitic inductance and capacitance. This includes connections to FB.
- 3) Use a ground plane.

Noise and Ripple Measurement

Accurately measuring the output noise and ripple is a challenge. Slight momentary differences in ground potential between the MAX840/MAX843/MAX844 circuit and the oscilloscope (which results from the charge pump's switching action) cause ground currents in the probe's wires, inducing sharp voltage spikes. For best results, measure directly across the output capacitor (C_4). Do not use the ground lead of the oscilloscope probe; instead, remove the probe's tip cover and touch the ground ring on the probe directly to C_4 's ground terminal. You can also use a Tektronix chassis-mount test jack (part no. 131-0258) to connect your scope probe directly. This direct connection gives the most accurate noise and ripple measurement.

Low-Noise, Regulated, -2V GaAsFET Bias

MAX840/MAX843/MAX844

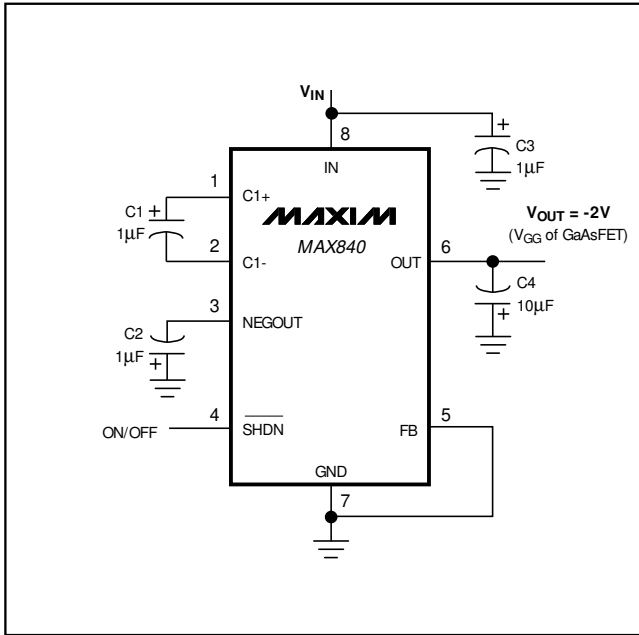

Figure 2a. MAX840 Standard Application Circuit

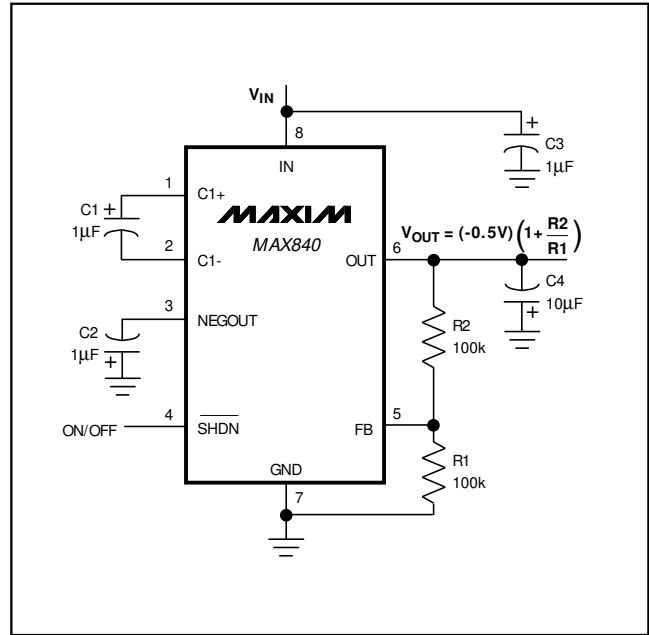

Figure 2b. MAX840 Adjustable Configuration

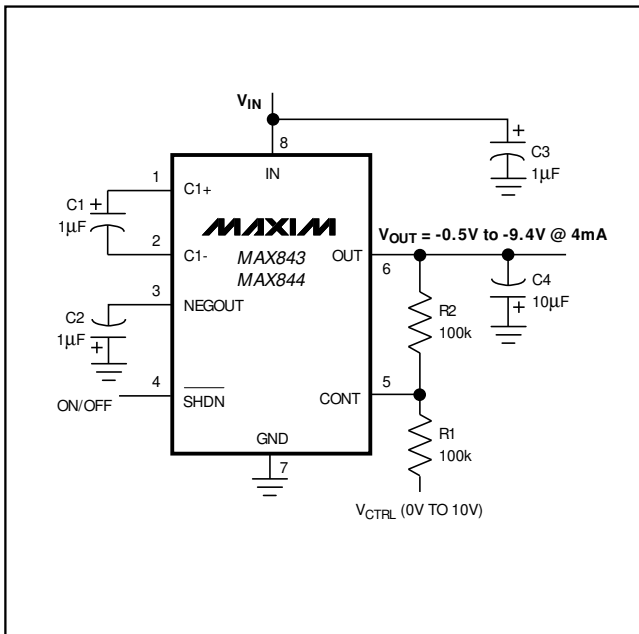

Figure 2c. MAX843/MAX844 Standard Application Circuit

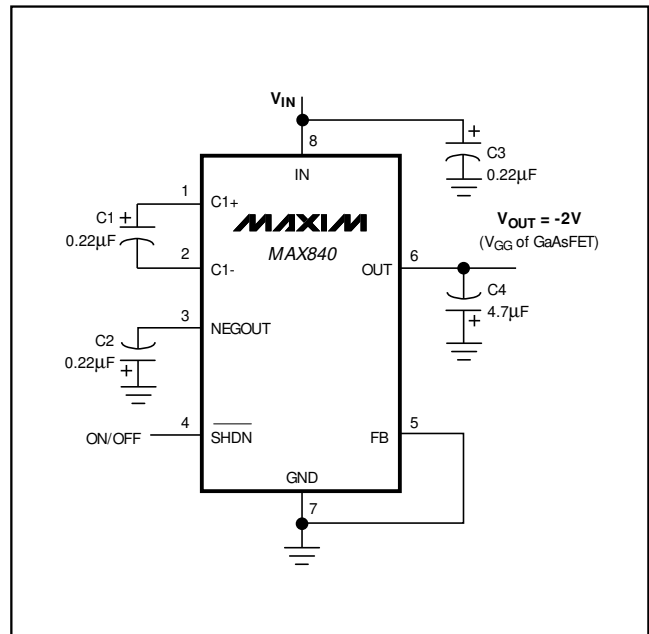
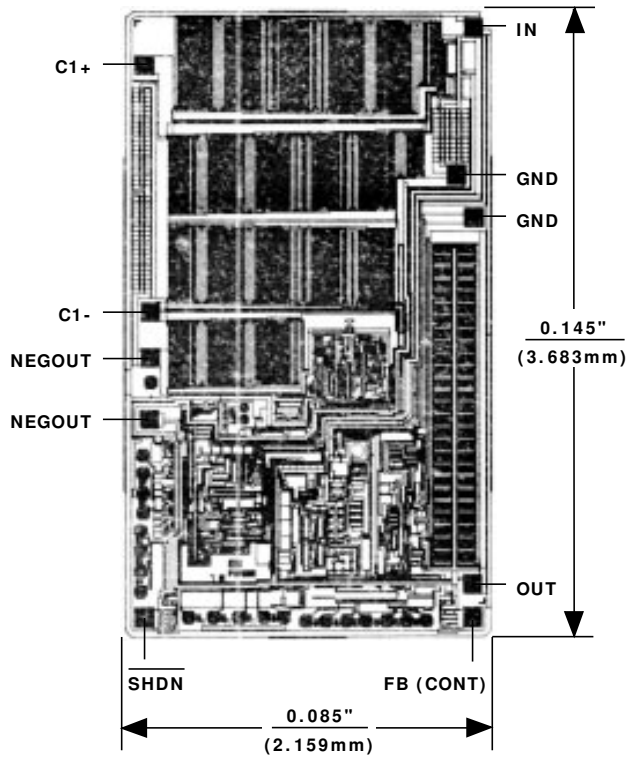

Figure 2d. MAX840 Application Circuit Using Smaller Capacitors

Low-Noise, Regulated, -2V GaAsFET Bias

Chip Topography

MAX840/MAX843/MAX844



() ARE FOR MAX843/MAX844

TRANSISTOR COUNT: 148

SUBSTRATE CONNECTED TO IN