

Ultra Low Noise, Ultra Compact, Isolated type DC-DC Converter

Bellnix®

1.5Watt BLA12 Series

Our BLA series isolated-type DC-DC converters feature a small package (14x20.3x9.7mm) and light weight (3.2g) capable of 1.5W output.

As ultralow noise and extremely high efficiency are made possible by a new circuit, it is ideal for an analog circuit as well as analog and digital hybrid circuit.



- Features
- Ultra low noise
- Adjustable Output Voltage
- ON/OFF Control
- Dual power supply usable as single power supply
- Withstand voltage AC500V
- Built-in Over Current Protection Circuit
- No tantalum capacitor or electrolytic capacitor
- Covered with a metal shield
- Surface Mount Package
- No heat sink needed
- Operating Temp Range -40°C to +85°C (Temperature derating required)
- RoHS Compliant

■ Model/Rating

Table 1

Models BLA12 Series	Input V Vdc	Output V Vdc	Output I mA	Line Reg. mV(max.)	Load Reg. mV(max.)	Ripple Noise mVpp(typ.)	Efficiency %(typ.)
BLA12-05S30	9 to 18	5	0 to 300	20	40	5	78
BLA12-12S12		12(15)	0 to 125(100)	40	100	5	81
BLA12-12W06		±12(±15)	0 to 60(50)	80	600	5	82

Note 1: Output voltage in parentheses is when V_{adj} and $-V_{out}$ are short-circuited.

Note 2: Output current in parentheses is at the maximum output voltage.

Note 3: Ripple noise and efficiency are at 12V input voltage and load rating.

Note 4: Ripple noise is measured at 20MHz bandwidth, with a multi layered ceramic capacitor with 10µF at input and 0.1µF at output.

■ Specifications

Table 2

Input voltage range	Refer to Table 1
Rated output voltage	5.0V±3%, 12V±3% , ±12V±5% (When V_{adj} terminal is open)
Adjustable output voltage range	4.75 to 6.0V (5.0V model), 11.4 to 15V (12V model), ±11.4 to ±15V (±12V model)
Line regulation	Refer to Table 1 (Rated output, Input voltage varying in the range of Table 1)
Load regulation	Refer to Table 1 (Rated input/output, Load varying from 0 to 100%, \pm output is upon balanced load)
Temperature regulation	40mV typ.(5.0V model), 100mV typ. (12V model), 150mV typ. (±12V model) (Rated input/output, for within ambient temperature range with 100% load at temperature derating)
Ripple noise	Refer to Table 1 (Rated input/output, common temp, measurement frequency bandwidth 20MHz)
Efficiency	78% to 82% typ. (Rated input/output, Common temp., Refer to Table 1)
Over current protection	Operate at 105% or above of rated load current. Auto restart type.
Over voltage protection	None
Under Voltage Lock Out	Yes
Input over current protection	None
Remote ON/OFF control	Between 2Pin ($-V_{in}$) and 3Pin (ON/OFF): Output is ON when open, output is OFF when short.
Standby current	6mA max.
Withstand voltage	Between input and output, input and case, output and case: One minute at AC500V.
Insulation resistance	Between input and output, input and case, output and case: 50MΩ or more (at DC500V)
Capacitance between P and S	Approx. 80 to 140pF (depending on the model)
Operating temp range	Operating temperatures -40°C to +85°C (Refer to temp derating described separately)
Storage temp range	Storage temperatures -40°C to +85°C
Humidity range	20 to 95%R.H. (Max. wet bulb temp 35°C with no condensation)
Storage conditions	Below 30°C/60% R.H. before mounting the converter
Cooling conditions	Natural cooling (install in a well-ventilated place)
Vibration	10 to 55Hz Total amplitude 1.52mmp-p (2H for each of three directions) Sweep time 15 min
Impact	Acceleration 100G (3 times for each of three directions, total 18 times) Duration 6ms
Weight	3.2g typ.
Outer dimensions	W=14 L=20.3 H=9.7 typ.(mm) (For dimensional details, refer to the shape and dimensions shown separately)

* The above specifications are provided with rated value, unless otherwise specified.

* The contents provided in this datasheet may be changed at any time without prior notice.

1. Scope

These specifications shall apply to the DC input, isolated type DC-DC converter BLA12 series.

2. Model/Rating

Model name	Rated input voltage	Rated output	Shape	Remarks
BLA12-05S30	DC12.0V	5.0V, 300mA	SMD	
BLA12-12S12		12.0V, 125mA		
BLA12-12W06		±12V, each 60mA		

Unless otherwise mentioned in these specifications, input shall be rated input, output shall be rated output, and ambient temperature shall be 25°C±5°C.

3. Environmental conditions

3-1 Temperature range

In operation -40°C to +85°C (Derating required)
 In storage -40°C to +85°C

3-2 Humidity range

In operation 20 to 95%R.H. (However, max. wet bulb temperature 35°C, no condensation)
 In storage 20 to 95%R.H. (However, max. wet bulb temperature 35°C, no condensation)

Note) For storage before mounting, store in a place below 30°C and 60% R.H.

4. Specifications & Standards

This product is RoHS compliant.

4-1 Input conditions and output characteristics

*1

Model name	Input voltage V	Output voltage V	Output current mA	Output voltage stability ^{*2}			Output ripple noise ^{*3} mVp-p typ. / max.	Efficiency ^{*4} % typ.
				Input mV max.	Load mV max.	Temp. mV typ.		
BLA12-05S30	9 to 18	5±3%	0 to 300	20	40	40	5/ 15	78
BLA12-12S12	9 to 18	12±3%	0 to 125	40	100	100	5/ 15	81
BLA12-12W06	9 to 18	±12±5%	0 to 60×2	80	600	150	5/ 15	82

*1 With the measurement circuit of 4-4. Unless otherwise mentioned, rated input and output, and ambient temperature shall be 25°C±5°C.

*2 Input: For fluctuations of input voltage = min. to max.

Load: For fluctuations of output current = 0 to rated.

Temperature: For fluctuations of ambient temperatures = -40 to T_{max}.

For within ambient temperature range with 100% load at temperature derating of 4-3.

A two output product is when + output current and – output current are equal.

*3 Measured frequency bandwidth 20MHz. At both ends of external capacitor (C2, or C4, C5).

*4 At rated input voltage and maximum output current.

4-2 Capacitance of external capacitor

This product has a limited capacitance for an output external capacitors. Limit the capacitance of an external capacitor as follows:

Output external capacitor

Model name	Capacitance	
	Plus output side	Minus output side
BLA12-05S30	0 to 100µF ^{*1}	—
BLA12-12S12	0 to 47µF ^{*1}	—
BLA12-12W06	0 to 22µF ^{*2}	0 to 22µF ^{*3}

*1 Total of C2 and C3 in the Standard Connection Circuit of 6.(1)

*2 Total of C2 and C4 in the Standard Connection Circuit of 6.(2)

*3 Total of C3 and C5 in the Standard Connection Circuit of 6.(2)

4-3 Temperature derating

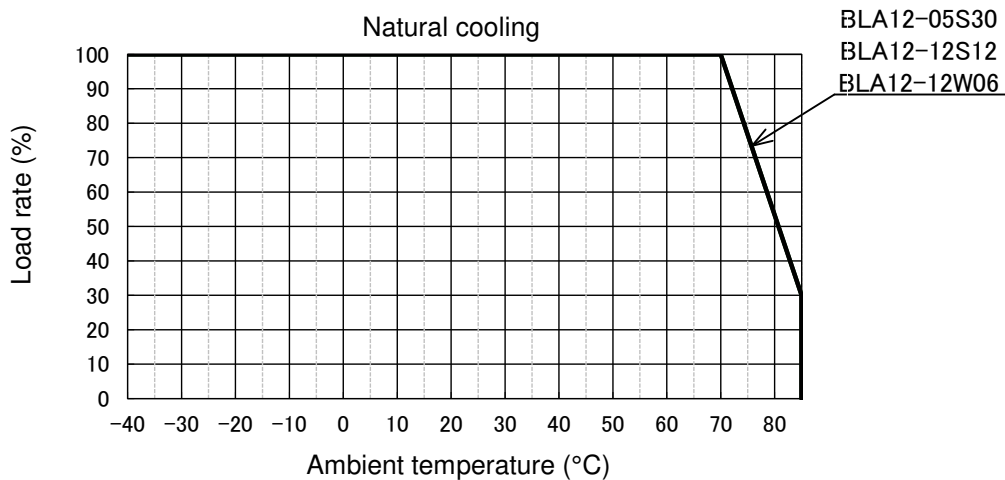

Note) at rated output

4-4 Measurement circuit

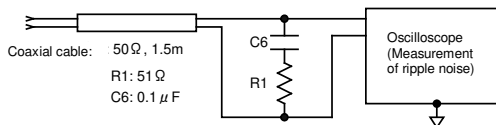
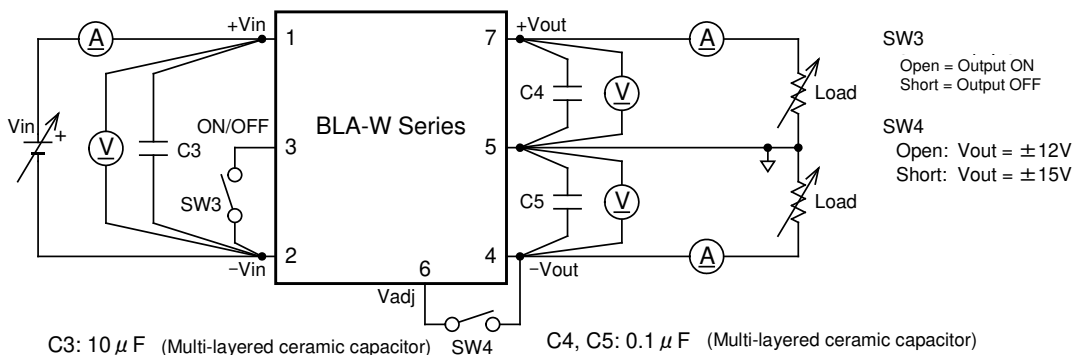
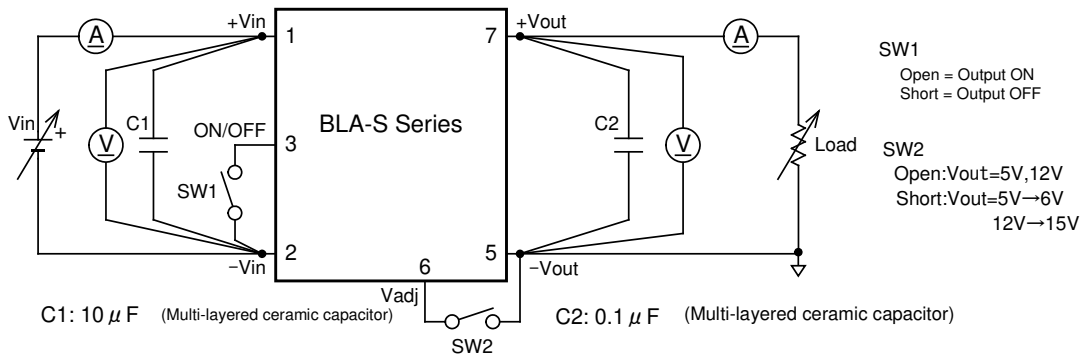

4-5 Additional functions

Item	Specifications & Standards	Conditions
Over current protection circuit	Operate at 105% or above, auto restart type.	
Over voltage protection circuit	None	
Adjustable output voltage range	4.75 to 6.0V (BLA12-05S30) 11.4 to 15V (BLA12-12S12) ±11.4 to ±15V (BLA12-12W06)	By external resistor Refer to 7-3
ON/OFF control	Open for output ON Low (0 to 0.3V, 4mA max.) for output OFF	Refer to 7-1

4-6 Withstand voltage and Insulation resistance

- 1) Withstand voltage
Between input and output, input and case, output and case: One minute at AC500V
- 2) Insulation resistance
Between input and output, input and case, output and case: 50MΩ or more (at DC500V)

5. Outer dimensions and description of terminals

5-1 Shape and dimensions

1 Pin mark

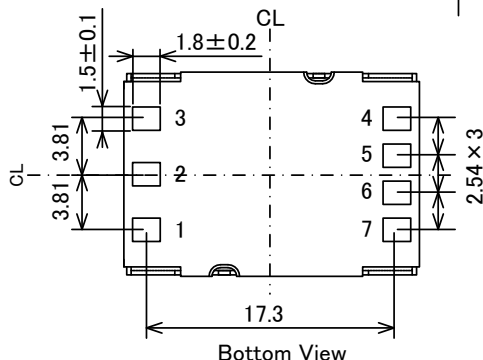
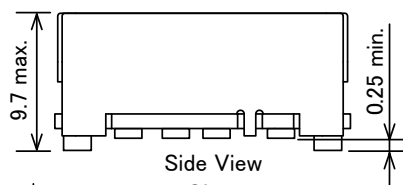
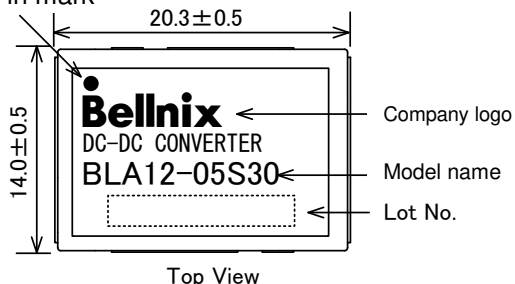

Pin	Function	
	BLA-S	BLA-W
1	+Vin	+Vin
2	-Vin	-Vin
3	ON/OFF	ON/OFF
4	NC	-Vout
5	-Vout	Com
6	Vadj	Vadj
7	+Vout	+Vout

Materials of terminals and case

- Terminal pin----- Material: Copper
Plating: Gold plating after nickel plating
- Case ----- Material: Nickel silver

- Unit: mm
- Dimensional tolerance (unless specified):±0.3
- Weight: 3.2g typ.
- Tolerance on terminals 0.2 mm max. (Max. lifting of the terminal part when placed on a plane)

5-2 Recommended footprint dimensions

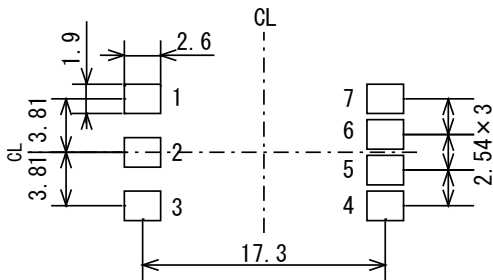

Note) Recommended dimensions are shown above. Use your design standard for your specific design.

5-3 Lot indication

2 8 (Manufactured in August 2012)

2 D 2 (Manufactured in December 2012)

- Production code for manufacturing control (may not be indicated)
- Manufacturing month (Jan to Sep = 1 to 9, Oct = O, Nov = N, Dec = D)
- Manufacturing year (the last digit of A.D.)

6. Standard connection circuit

6-1 BLA-S series

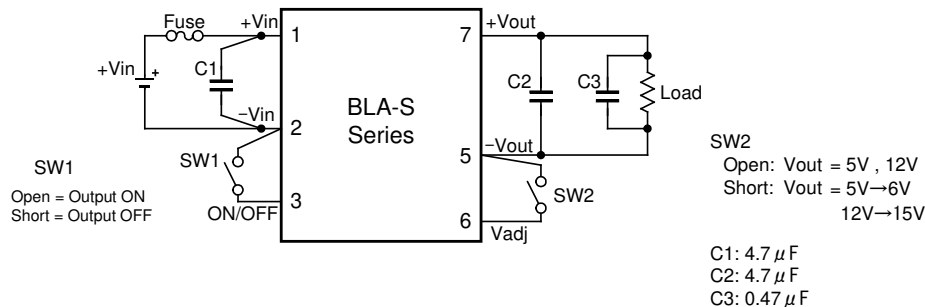

6-2 BLA-W series

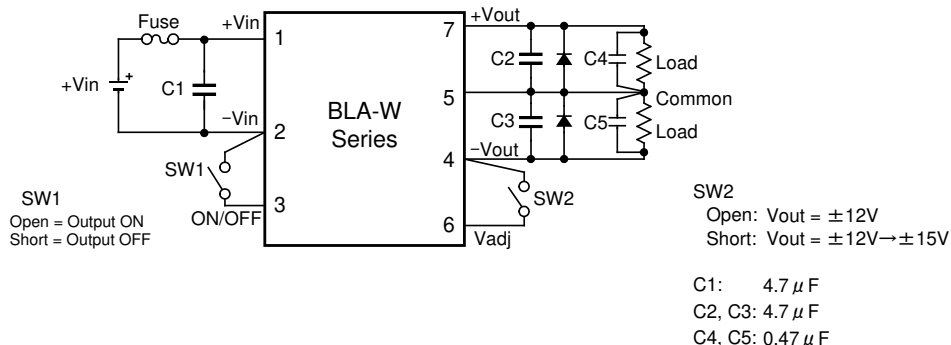

Note) This product has no built-in fuse. Always connect a fuse to the +Vin line. Allow enough capacity for power supply for a fuse to blow.

7. Various functions

7-1 ON/OFF control

The ON/OFF control function enables users to control ON/OFF of the output voltage without inputting or cutting it off.

Between $-V_{in}$ terminal (No. 2 pin) and ON/OFF terminal (No. 3 pin)

- Open (5V max.) : Output ON
- Short (0 to 0.3V 4mA max.) : Output OFF

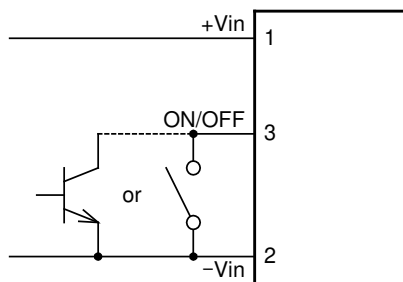

7-2 Output over current protection

If output current has reached over current status, output voltage is lowered and the over current protection circuit is activated. (Over current protection circuit actuating current: 105% or above of the rated load current)

The converter automatically returns to normal operation as soon as over current status is resolved. Holding of over current status for over 30 seconds may result in damage, so resolve over current status within 30 seconds.

Also, if the converter does not return to normal operation automatically even if the over current status has been resolved, turn off the power once or turn the output OFF with an ON/OFF control and reactivate.

Characteristics in the over current mode

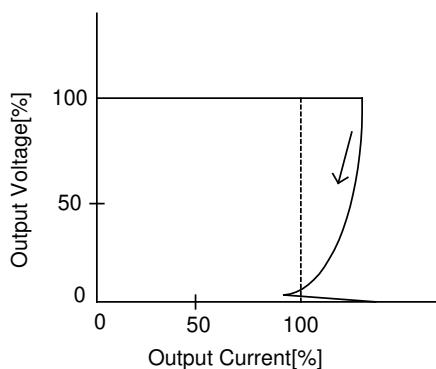

Note) The drooping characteristic may be seen in the over current protection characteristics as shown on the left. Note that output voltage may not come up upon the activation if connected to a nonlinear load such as a lamp, motor, etc., or a constant current load.

7-3 Output voltage adjustment

7-3-1 Short circuit Vadj and -Vout terminal

Output voltage can be set at the maximum as per the following table by short-circuiting Vadj and -Vout terminals. In case of no variable output voltage, open the terminal.

Output voltage for the connection of Vadj terminal

Model name	Between Vadj and -Vout terminals	
	Open	Short
BLA12-05S30	5.0V	6.0V
BLA12-12S12	12.0V	15.0V
BLA12-12W06	±12.0V	±15.0V

7-3-2 Resistor adjustment control

The output voltage is adjustable by inserting a resistor between Vadj terminal and +Vout terminal or -Vout terminal.

To decrease the output voltage

To increase the output voltage

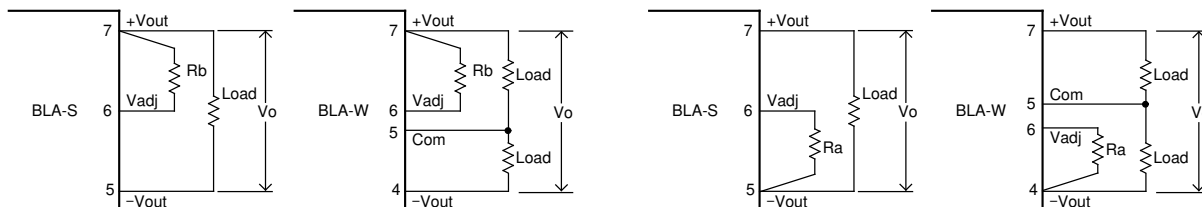

Model name	To decrease the output voltage Output voltage: Vo[V], Connecting resistor: Rb[kΩ]	To increase the output voltage Output voltage: Vo[V], Connecting resistor: Ra[kΩ]
BLA12-05S30	$V_o = (2490 R_b + 7221) / (500 R_b + 1700)$ $R_b = (7221 - 1700 V_o) / (500 V_o - 2490)$ Variable range: Vo=4.75V min.	$V_o = (2490 R_a + 7221) / (500 R_a + 1200)$ $R_a = (7221 - 1200 V_o) / (500 V_o - 2490)$ Variable range: Vo=6.0V max.
BLA12-12S12	$V_o = (2996 R_b + 17643) / (250 R_b + 2605)$ $R_b = (17643 - 2605 V_o) / (250 V_o - 2996)$ Variable range: Vo=11.4V min.	$V_o = (2996 R_a + 17643) / (250 R_a + 1175)$ $R_a = (17643 - 1175 V_o) / (250 V_o - 2996)$ Variable range: Vo=15.0V max.
BLA12-12W06	$V_o = (10607 R_b + 67006) / (440 R_b + 12012)$ $R_b = (67006 - 12012 V_o) / (440 V_o - 10607)$ Variable range: Vo=22.8V min. (±11.4V min.)	$V_o = (2652 R_a + 26977) / (110 R_a + 902)$ $R_a = (26977 - 902 V_o) / (110 V_o - 2652)$ Variable range: Vo=30.0V max. (±15.0V max.)

Note) If output voltage is made variable, use at the maximum power (1.5W) or less.
 If output voltage is made lower, do not connect Rb to resistor which is less than Vo min. setting resistor value.

7-4 Activation and deactivation voltage

This product has an under voltage lock out function to prevent malfunction when low input voltage. The activation voltage and deactivation voltage is within the range shown in the table below.

Ambient temperature	Range of activation and deactivation voltage
-40 to 85°C	7 - 8.3V

8. Protection against reverse connection of input power supply (example)

This product will be damaged if erroneously connected with reverse input polarity. To cope with a possible reverse connection, add a protection circuit as shown in the following figure.

The following is an example using a fuse and a diode.

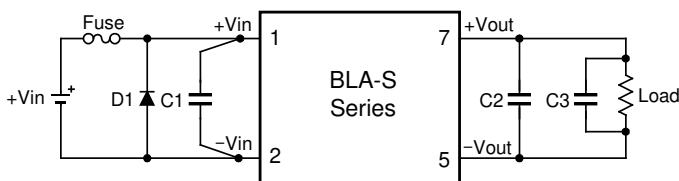

9. Common mode noise reduction method (example)

To reduce common mode noise of this product, connect a capacitor of 1000pF or so (C4) between the primary and secondary terminals. In this case, note that using a capacitor of too much capacitance may result in the increase of coupling capacitance between primary and secondary terminals.

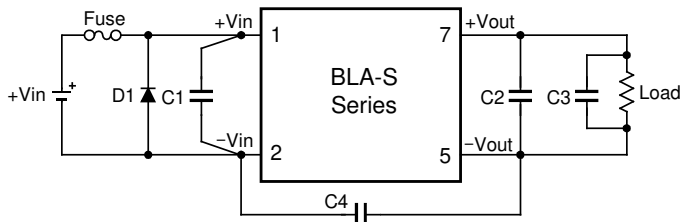

10. Input feedback noise reduction method (example)

Input feedback noise can be reduced by designing a Pi filter at input side. Add as needed.

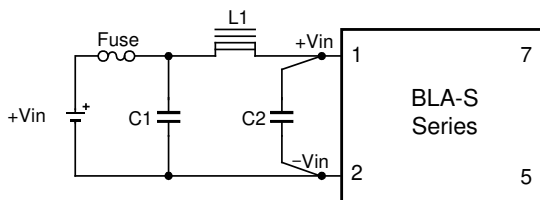

11. Serial operation method (example)

Serial operation is possible by wiring this product as per the following figure. Limit the output current not to exceed the smaller rated current of the power supplies connected in series to avoid more current than rating to run into the power supply.

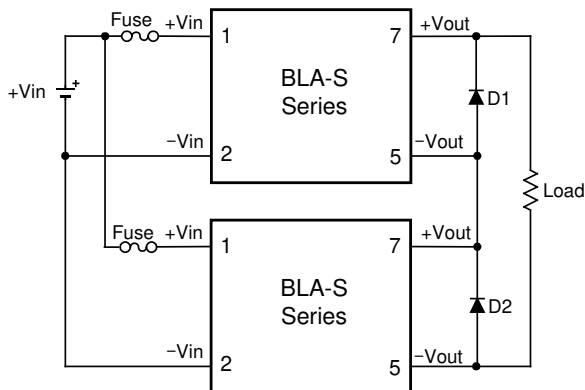

Note) This product is not suitable for parallel operation.
Schottky diodes of low forward voltage are recommended for D1 and D2.

12. Soldering conditions

Observe the following conditions for soldering temperature and time. Flow mounting is not possible for this product.

Reflow method

Reflow temperature profile

In the case of Sn-3Ag-0.5Cu series solder

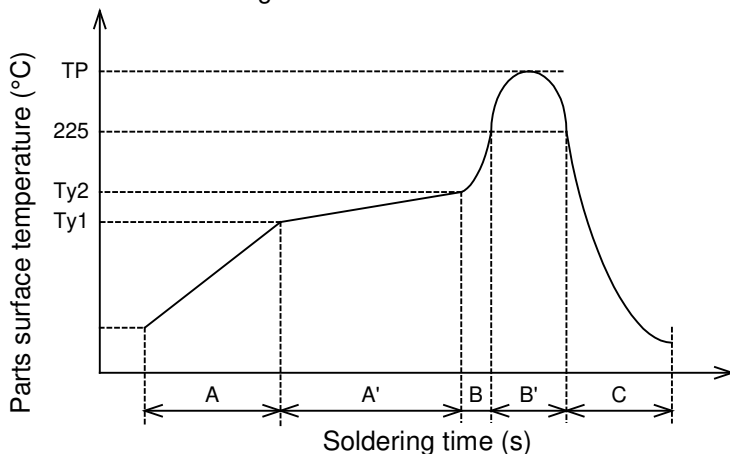

A	1.0 ~ 3.0°C/s	
A'	Ty1:	150±10°C
	Ty2:	170±10°C
	Ty1 ~ Ty2:	40 ~ 100s
B	1.0 ~ 4.0°C/s	
B'	TP:	245°Cmax.
	225°C or higher:	20 ~ 40s
C	1.0 ~ 5.0°C/s	

Refrain from causing vibration of the product during the reflow.
The number of reflows shall be once (no mounting of the reverse side).
* Eutectic solder may be used so far as within the above profile conditions.

13. Vibration and impact tests

Vibration 10 to 55Hz Total amplitude 1.52mmp-p (2H for each of three directions)
Sweep time 15 minutes
Impact Acceleration 100G (3 times for each of 3 directions, total 18 times)
Impact time 6ms

14. Cleaning

This product is not for immersible cleaning. Use of no-clean flux is recommended.

15. Precautions for use

To ensure user's safety, check specifications before using the product and always observe the following precautions for use.

- This product is intended for use in general electronics equipment (office equipment, communication equipment, measurement equipment). Do not use the product for medical equipment, nuclear equipment, trains, etc., whereby human life or property may be directly affected by damaged product. Consult with us for any use other than for such general electronics equipment.
- Minor changes and component parts changes that do not affect contents of the specifications will be made due to characteristic improvement of the product and other reasons without prior notice.
- This product is not suitable for parallel operation.
- Do not use connectors and sockets for mounting the product. Contact resistance may have an adverse effect on the performance. Use the soldering method for mounting on the printed circuit board.
- This equipment has a built-in over current protection circuit but avoid a prolonged short circuit which may lead to failure.
- This product may be damaged if used under nonstandard electrical conditions or nonstandard environmental conditions including temperature. Ensure use within the standards.
- Avoid using this product in a place that generates corrosive gas or is dusty.
- This product may be damaged by static electricity. Make sure that the workplace is guarded against static buildup and static electricity on operators by use of proper grounding.
- A fuse mechanism is not built in this product. Connect a fuse suitable in terms of blowout characteristics and I²t characteristics to + input line to guard against excessive input current under abnormal circumstances. Allow enough capacity in the power supply for a fuse to blow.
- This product has no built-in function for over voltage protection.
- This product does not come with a test report.

16. Warranty

The warranty term of the product is one year after shipment. Should the product become defective within the warranty period due to our design or workmanship, the product will be repaired free of charge or replaced. However, this warranty does not cover products which have been subjected to unauthorized inner modifications, etc.

The scope of our warranty is limited to that of the said product.

17. Contact

If you have any further technical questions for this product, please contact us.

E-mail: info@bellnix.com

URL: <http://www.bellnix.com>