

### DESCRIPTION

The EV2341-TL-00A Evaluation Board is designed to demonstrate the capabilities of MP2341GTL. The MP2341 is a 24V monolithic synchronous step-down white LED driver with a built-in power MOSFET and rectifier. It achieves up to 2A continue output current with excellent load and line regulation in a tiny SOT583 package. Peak current mode operation provides fast transient response and eases loop stabilization.

The EV2341-TL-00A is typically designed for driving 2 WLEDs in series (5.9V<sub>TYP</sub>) LED load with 2A current at wide 8V to 24V input range.

The EV2341-TL-00A has high performances in efficiency, line/load regulation, deep dimming range with both analog and PWM mode. Fault condition protection includes cycle-by-cycle peak current limiting, output short circuit protection, open LED protection and thermal shutdown.

### ELECTRICAL SPECIFICATION

Parameter	Symbol	Value	Units
Input Voltage	V <sub>IN</sub>	8 to 24	V
Output Voltage	V <sub>OUT</sub>	5.9	V
LED Current	I <sub>LED</sub>	2	A

### FEATURES

- 8V to 24V Wide Input Range
- 125mΩ/75mΩ Low-R<sub>DS(ON)</sub> Internal Power MOSFETs
- 100mV Feedback Voltage
- Up to 95% Efficiency
- Fixed 1MHz Switching Frequency
- Analog Dimming by DC voltage through EN/DIM
- Analog Dimming by PWM signal through PDIM
- PWM Dimming by PWM signal through EN/DIM
- 50:1 Dimming Ratio by Analog Dimming
- 1000:1 Dimming Ratio by PWM Dimming
- LED Open Protection
- Over-Current Protection and Hiccup
- Over Voltage Protection with Auto Recovery
- Thermal Shutdown

### APPLICATIONS

- Infrared LED Driver
- General LED Driver
- Flashlight
- Handheld Computers Backlight

All MPS parts are lead-free, halogen free, and adhere to the RoHS directive. For MPS green status, please visit MPS website under Quality Assurance. "MPS" and "The Future of Analog IC Technology" are Registered Trademarks of Monolithic Power Systems, Inc.

## EV2341-TL-00A EVALUATION BOARD



(L x W x H) 46mm x 46mm x 6mm	
Board Number	MPS IC Number
EV2341-TL-00A	MP2341GTL

### Efficiency vs. VIN

2 WLEDs in series, V<sub>OUT</sub>=5.9V, L = 6.5μH, I<sub>LED</sub>=2A

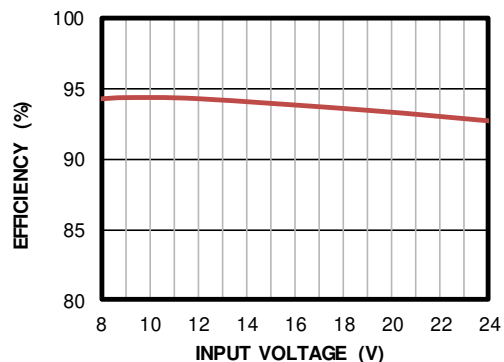

## EVALUATION BOARD SCHEMATIC

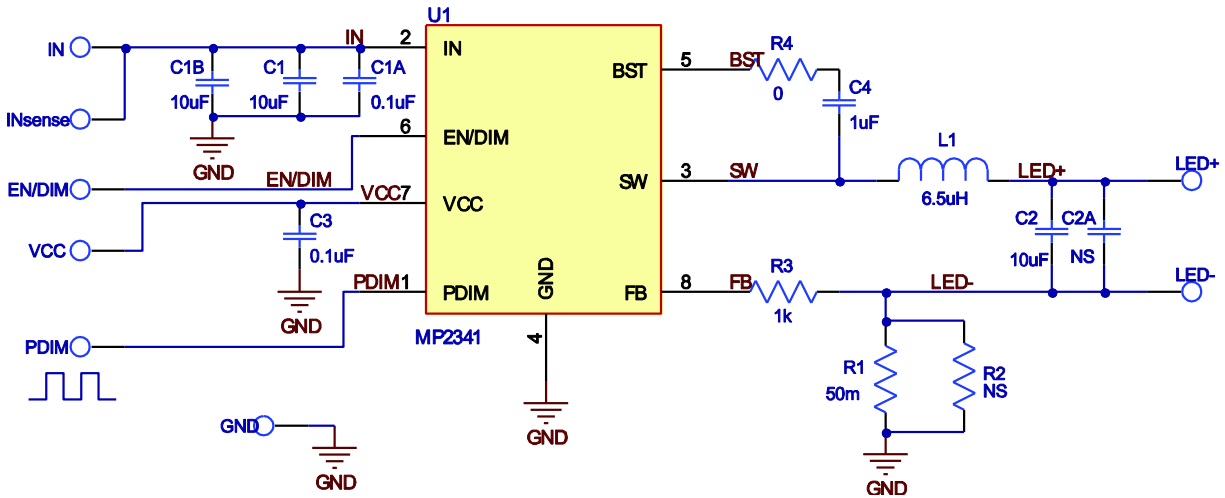

## EV2341-TL-00A BILL OF MATERIALS

Qty	Ref	Value	Description	Package	Manufactur	Manufacturer_P/N
2	C1, C1B	10µF	Ceramic Cap., 35V,X5R	0805	Murata	GRM21BR61E106KA43L
1	C1A	0.1µF	Ceramic Cap., 50V,X7R	0603	Murata	GRM188R71H104KA93D
0	C2A	NS				
1	C2	10µF	Ceramic Cap., 16V,X5R	0805	Murata	GRM21BR61C106KE15L
1	C3	0.1µF	Ceramic Cap., 16V,X7R	0603	Murata	GRM188R71C104KA01D
1	C4	1µF	Ceramic Cap., 16V,X7R	0603	Murata	GRM188R71C105KE15D
1	R1	50mΩ	Sense resistor, 1W	1206	YAGEO	PE1206FRF470R05L
0	R2	NS				
1	R3	1KΩ	Film Res,1%,0603,1K	0603	YAGEO	RC0603FR-071KL
1	R4	0Ω	Film Res,1%,0603,0R	0603	YAGEO	RC0603JR-070RL
1	L1	6.5µH	Inductor, R <sub>DC</sub> =21.5mΩ, Isat=6A	7x7x5mm	Würth	744314650
		6.8µH	Inductor, R <sub>DC</sub> =31mΩ, Isat=4.3A	6x6x4.5mm	Sunlord	SWPA6045S6R8MT
1	U1	MP2341	24V, 2A LED driver	SOT583	MPS	MP2341GTL

## EVB TEST RESULTS

Performance waveforms are tested on the evaluation board.

$V_{IN} = 12V$ , 2 WLEDs in series,  $V_{OUT}=5.9V$ ,  $L = 6.5\mu H$ ,  $T_A = +25^\circ C$ , unless otherwise noted.

**Efficiency vs. VIN**

$V_{OUT}=5.9V$

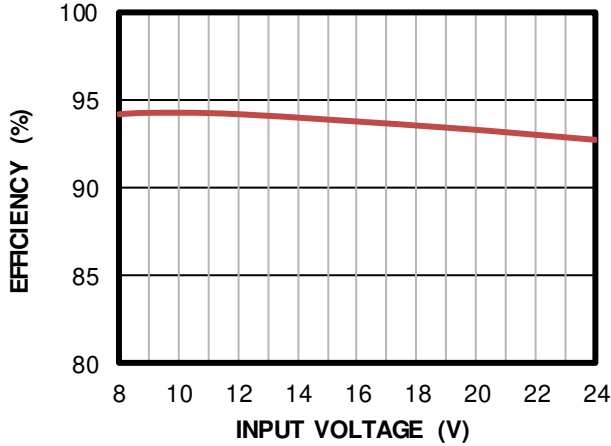

**Analog Dimming Curve**

Ramp up/down EN/DIM voltage

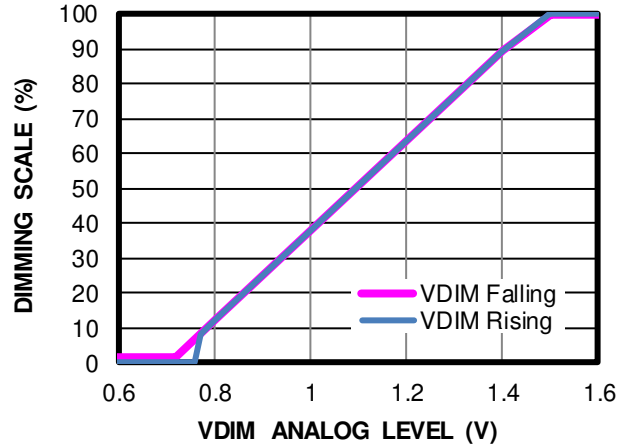

**Analog Dimming Curve**

PDIM frequency=20kHz

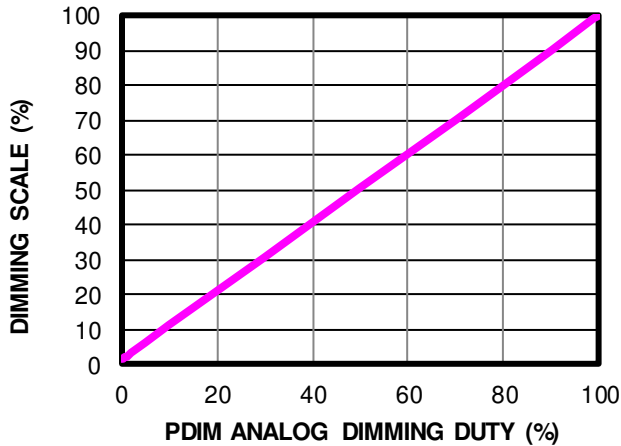

**PWM Dimming Curve**

EN/DIM frequency=200Hz

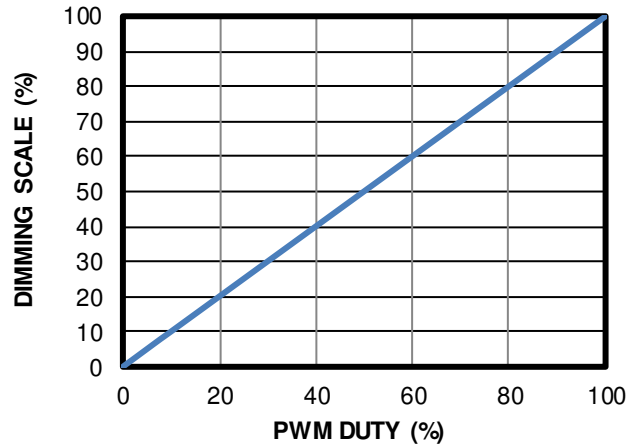

**Thermal Test**

$V_{OUT}=5.9V$

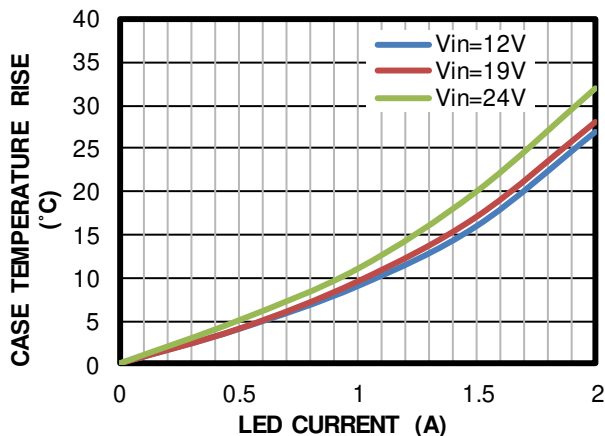

## EVB TEST RESULTS *(continued)*

Performance waveforms are tested on the evaluation board.

$V_{IN} = 12V$ , 2 WLEDs in series,  $V_{OUT}=5.9V$ ,  $L = 6.5\mu H$ ,  $T_A = +25^\circ C$ , unless otherwise noted.

### Steady State

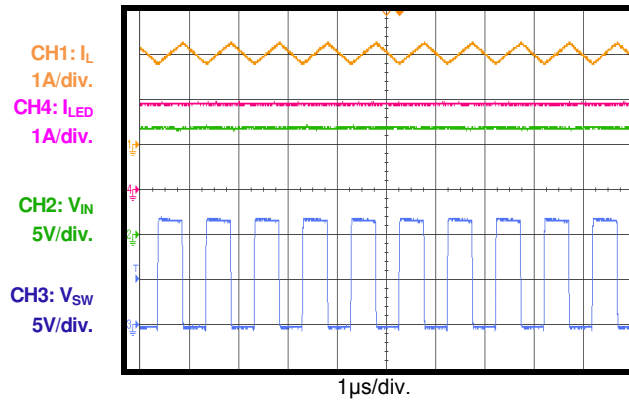

### VIN Start-Up

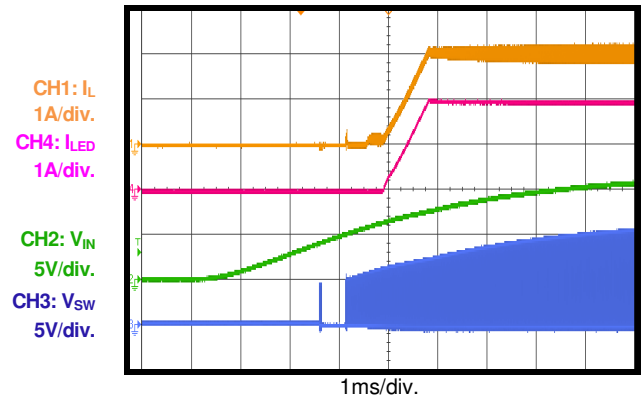

### VIN Shutdown

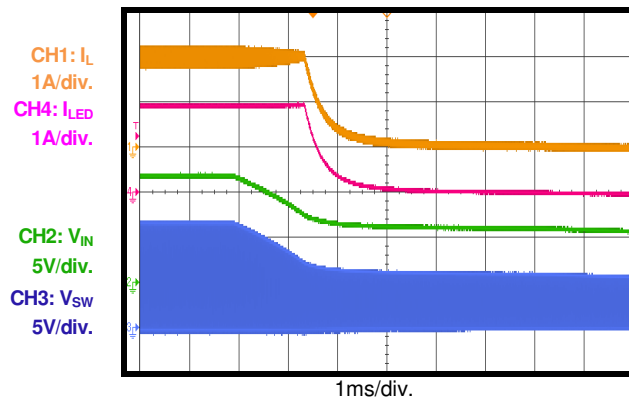

### EN Start-Up

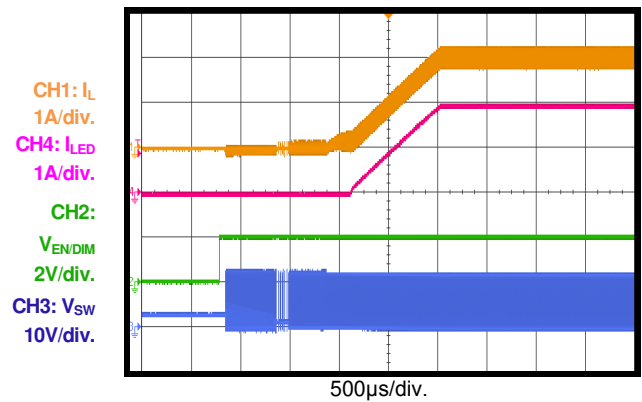

### EN Shutdown

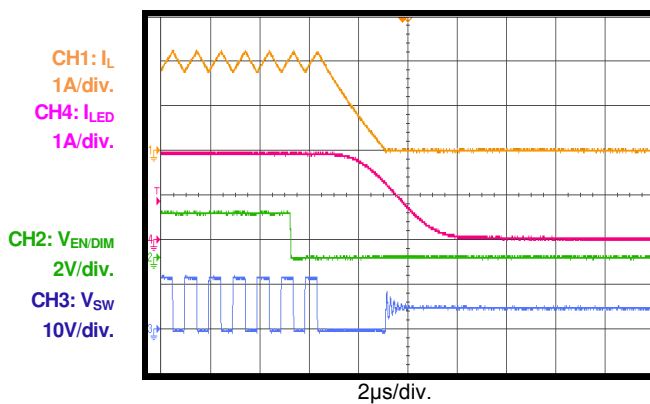

### Minimum Analog Dimming

$V_{PDIM}=2V$ , Frequency=20kHz, Duty=0.63%,  $V_{FB}=1mV$

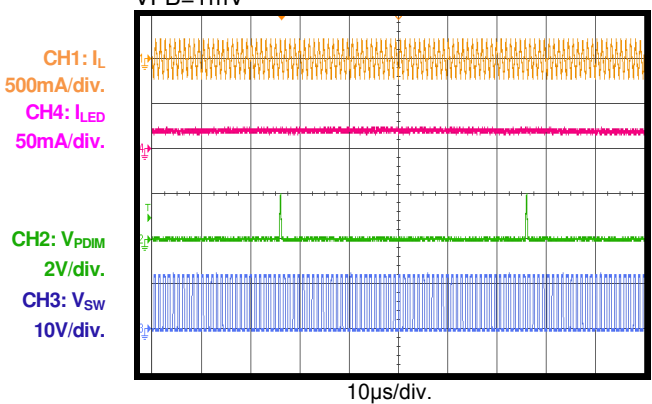

## EVB TEST RESULTS *(continued)*

Performance waveforms are tested on the evaluation board.

$V_{IN} = 12V$ , 2 WLEDs in series,  $V_{OUT}=5.9V$ ,  $L = 6.5\mu H$ ,  $T_A = +25^\circ C$ , unless otherwise noted.

### PWM Dimming

$V_{EN}/DIM=2V$ , Frequency=1kHz, Duty=50%

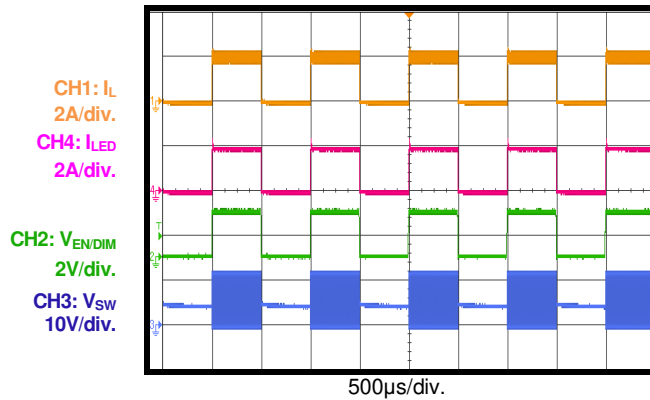

### Open LED protection

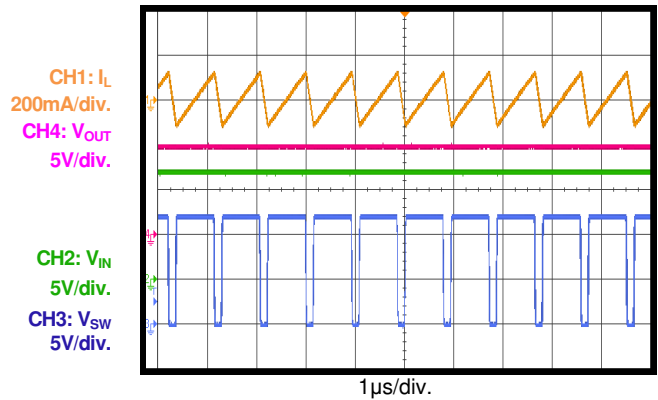

### Short LED+ to LED- Protection

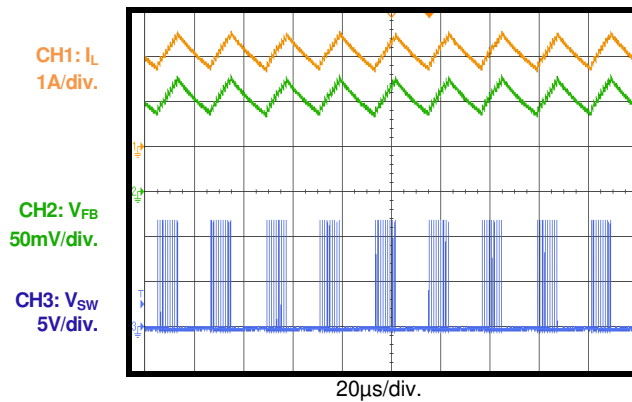

### Short LED+ to GND protection

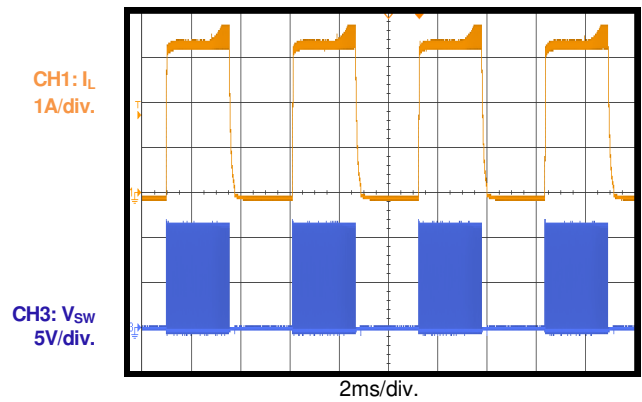

## PRINTED CIRCUIT BOARD LAYOUT

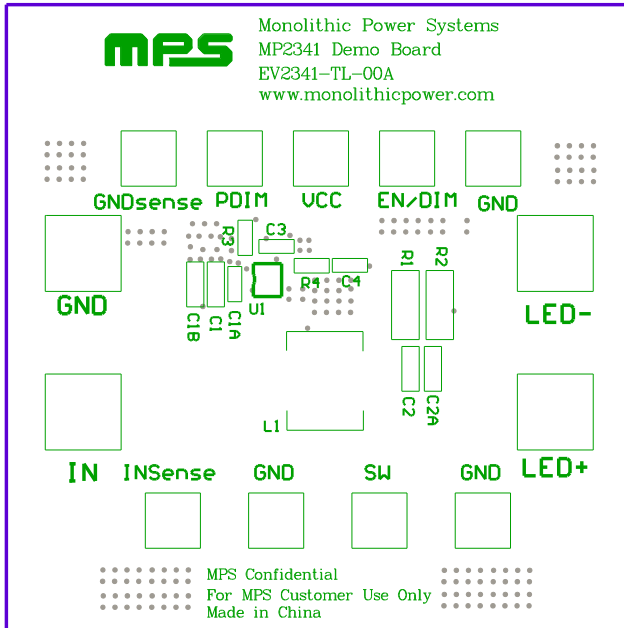

Figure 1 - Top Silk Layer

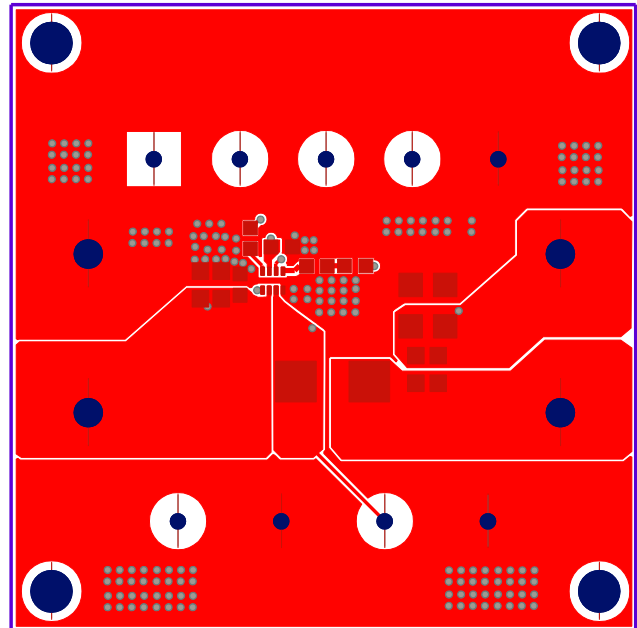

Figure 2 - Top Layer

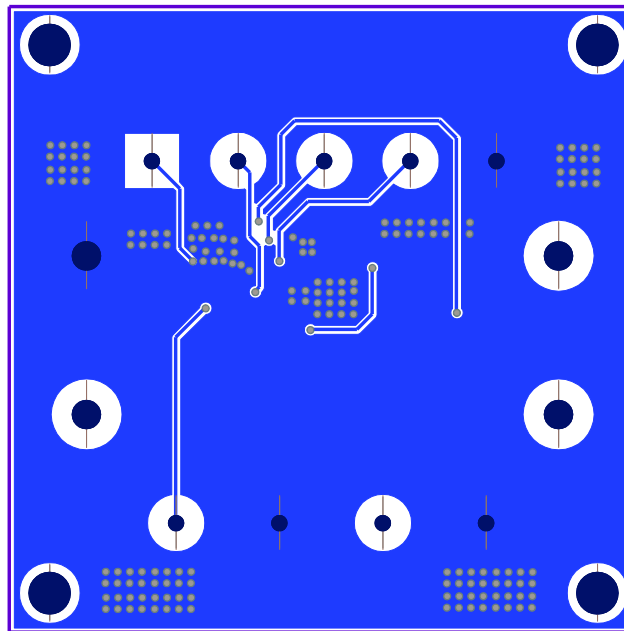

Figure 3 - Bottom Layer

## QUICK START GUIDE

1. Preset DC Power Supply output to 8V to 24V and turn off Power Supply.
2. Connect the positive terminal of Power Supply output to the VIN pin and the negative terminal to the GND pin.
3. Connect the LED load between “LED+” (anode of LED string) and “LED-“(cathode of LED string).
4. Turn on Power Supply. The EV2341-TL-00A will automatically startup.
5. To use the Enable function, apply the Enable voltage to the EN/DIM pin and drive Enable high to turn on the chip. When Enable voltage is less than 0.27V, the chip is turned off.
6. There are two ways to apply analog dimming. One is connecting a variable DC signal (0.7V to 1.44V) to EN/DIM pin and GND pins, respectively. By adjusting the voltage level from 0.7V to 1.44V, the LED current changes from the min scale to full scale of the maximum LED current. If the dimming voltage is higher than 1.57V, the maximum LED current is generated. Another analog dimming way is connecting the PWM signal to PDIM pin and GND pins, respectively. Recommend to set dimming frequency higher than 10kHz, and the positive plateau should be higher than 1.5V, the negative plateau should be lower than 0.4V.
7. To apply PWM dimming, connect the PWM signal (the positive plateau should be higher than 1.57V, the negative plateau should be lower than 0.27V) to EN/DIM and GND pins, respectively. The dimming frequency is recommended to be in the range of 100Hz to 2kHz to achieve good dimming linearity.

**NOTICE:** The information in this document is subject to change without notice. Please contact MPS for current specifications. Users should warrant and guarantee that third party Intellectual Property rights are not infringed upon when integrating MPS products into any application. MPS will not assume any legal responsibility for any said applications.