

## EVALUATION BOARD DESCRIPTION

The AD9261 is a 16-bit analog-to-digital converter (ADC) featuring a high performance and wideband continuous time sigma-delta ( $\Sigma$ - $\Delta$ ) modulator followed by decimation filters and a sample rate converter. An on-chip PLL based clock multiplier and voltage reference are available for ease of implementation and optimal performance. Figure 1 shows the functional block diagram of the AD9261.

The AD9261 evaluation platform offers flexibility in evaluating and characterizing the performance of the ADC. The evaluation board provides two options to drive the inputs of the ADC: a differential amplifier (AD4937-1) and a transformer path. The

on-board ADR130B provides an accurate and stable band-gap voltage for an optional external reference, and the AD9516-0 provides the ADC with many clocking options.

Complementing the AD9261 evaluation board are additional hardware and software to capture and process the digital data from the output of the ADC. The AD9261 can only be evaluated using the HSC-ADC-EVALCZ high speed ADC data capture card in conjunction with the VisualAnalog™ data capture and analysis software. The SPIController™ software is used to read and write to the AD9261.

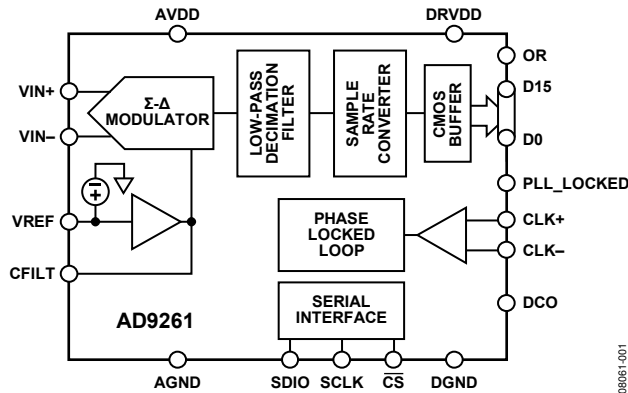

Figure 1. AD9261 Functional Block Diagram

### Rev. PrA

Evaluation boards are only intended for device evaluation and not for production purposes. Evaluation boards are supplied "as is" and without warranties of any kind, express, implied, or statutory including, but not limited to, any implied warranty of merchantability or fitness for a particular purpose. No license is granted by implication or otherwise under any patents or other intellectual property by application or use of evaluation boards. Information furnished by Analog Devices is believed to be accurate and reliable. However, no responsibility is assumed by Analog Devices for its use, nor for any infringements of patents or other rights of third parties that may result from its use. Analog Devices reserves the right to change devices or specifications at any time without notice. Trademarks and registered trademarks are the property of their respective owners. Evaluation boards are not authorized to be used in life support devices or systems.

**TABLE OF CONTENTS**

Evaluation Board Description.....	1	AD9516 SPI Controller .....	5
Getting Started.....	3	AD9516 Register Settings.....	6
Configuring the Evaluation Board .....	4	VisualAnalog Overview.....	7
Power Supply.....	4	Schematics .....	8
Clock .....	4	Layout.....	13
Differential Transformer Path .....	4	Ordering Information.....	17
Amplifier Driver Path .....	4	Bill of Materials.....	17
Supporting Hardware and Software.....	5	Ordering Guide .....	20
Software .....	5	ESD Caution.....	20
Hardware .....	5		
AD9261 SPI Controller.....	5		

GETTING STARTED

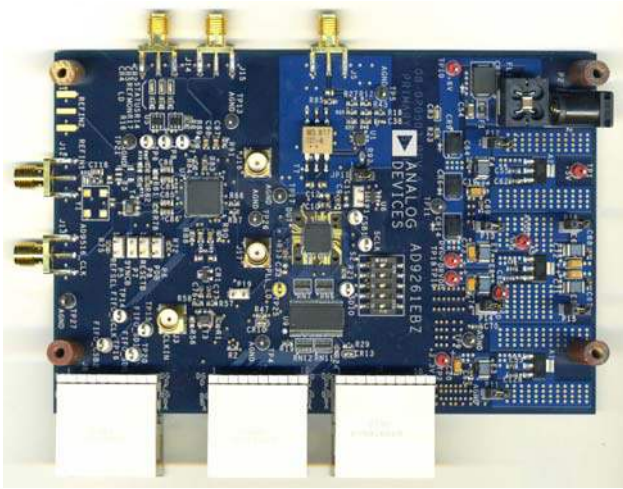

Figure 2. Evaluation Board Front

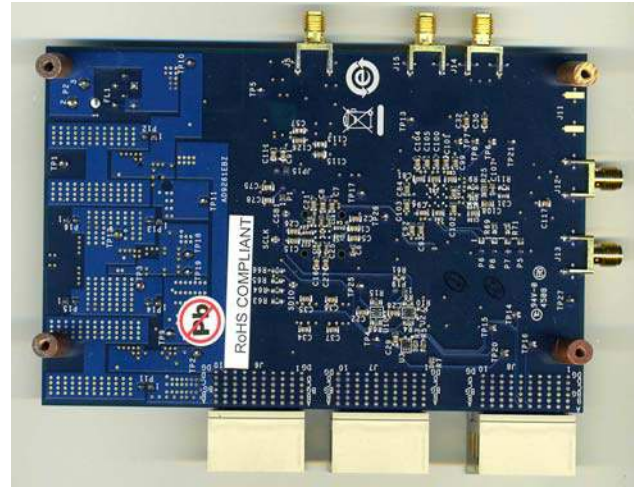

Figure 3. Evaluation Board Back

The default configuration of the AD9261 evaluation board allows a quick and easy start to evaluating the ADC. The default configuration uses a transformer to drive the single-ended to differential inputs of the AD9261 and an external 640MHz for the clock input. Table 1 and Figure 4 show the hardware required to start the evaluation.

Table 1.

Name	Board	Value	Reference Designator
Power	AD9261EBZ	+6 V	P2
	HSC-ADC-EVALCZ	+5 V	
Clock	AD9261EBZ	640 MHz	J3
ADC Input	AD9261EBZ	0 MHz to 10 MHz	J5
USB	HSC-ADC-EVALCZ	Connect USB to computer	

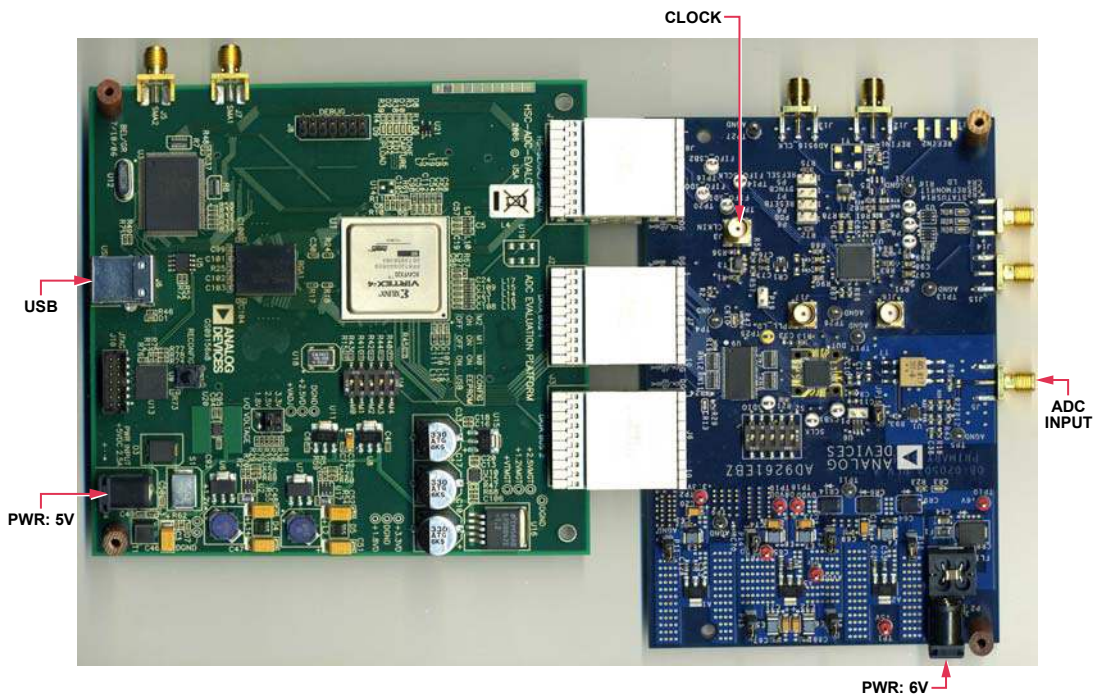

Figure 4. Quick Start Configuration

## CONFIGURING THE EVALUATION BOARD

### POWER SUPPLY

Power is provided to the evaluation board by a single +6.0 V source applied to P2. The power source is regulated down to the appropriate levels by the ADP3339 voltage regulators. Table 2 shows the necessary voltage levels for each component.

**Table 2. Component Power Supplies**

Component	Power Supply
AD9261	1.8 V
ADA4937-1	5.0 V
AD9516-0	3.3 V

### CLOCK

The AD9261 evaluation board offers many clocking options: a high frequency external clock can be applied directly to the ADC; the AD9516-0 LVPECL or CMOS clock can be used; and a low frequency clock, in conjunction with the integrated PLL from either the AD9516-0 or AD9261, can provide the necessary input clock frequency. The default clock option is configured for an external clock rate of 640 MHz.

The AD9261 evaluation board includes the footprint for a Valpey Fisher VFAC3 crystal oscillator. The crystal oscillator can serve as the reference clock to the AD9516-0, and the chip's internal PLL can be used to generate a clock closest to the desired frequency for the ADC. For example, a 122.88 MHz reference produces a VCO frequency of 2.580 GHz.

The AD9516-0 possesses an integrated VCO. The VCO frequency is further divided down by 4 to generate an output clock of 645 MHz, which serves as the input clock to the ADC. To optimize the AD9516-0 for this particular frequency, the loop filter must be configured as shown in Figure 5.

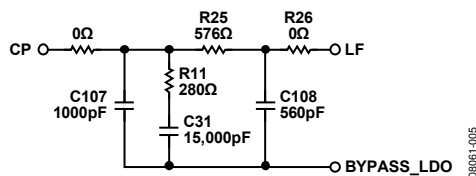

Figure 5: AD9516-0 Loop Filter

If the user chooses an alternative crystal oscillator frequency, the loop filter components must be configured appropriately. Some common crystal oscillators and the corresponding loop filter components are shown in Table 3. Refer to the ADIsimCLK software for design guidance.

**Table 3. AD9516-0 CLK Configuration**

Crystal (MHz)	Loop Filter					AD9261 CLK
	C107	R11	C31	R13	C108	
134.4	1000 pF	232 Ω	18,000 pF	486 Ω	680 pF	672 MHz
122.88	1000 pF	280 Ω	15,000 pF	576 Ω	560 pF	645.12 MHz
39.3216	1500 pF	221 Ω	22,000 pF	453 Ω	680 pF	648.8 MHz

To configure the evaluation board for either the external clock source or the AD9516-0 requires modifying the JP2 and JP5 solder jumpers. The AD9261 sets the common-mode level of the input clock to 450 mV; therefore, the clock source should be ac-coupled to the ADC input clock pins. Use the AD9516-0 software to configure the chip to the appropriate divide ratios.

### DIFFERENTIAL TRANSFORMER PATH

The differential transformer path is the default configuration. Table 4 shows the jumper settings for this configuration.

**Table 4: Differential Transformer Configuration**

Jumper	Setting	Notes
JP1	Short Position 2 and Position 3	Configure SMA connectors for the transformer inputs
JP3	Short Position 1 and Position 2	Configure differential transformer outputs to ADC inputs
JP4	Short Position 2 and Position 3	

### AMPLIFIER DRIVER PATH

To configure the evaluation board for the ADA4937-1 driver amplifier, set the jumpers as shown in Table 5.

**Table 5: ADA4937 Configuration**

Jumper	Setting	Notes
JP1	Short Position 1 and Position 2	Configure the SMA connectors for the ADA4937 inputs
JP3	Short Position 2 and Position 3	Configure outputs from the ADA4937 to ADC inputs
JP4	Short Position 1 and Position 2	

## SUPPORTING HARDWARE AND SOFTWARE

The AD9261 can only be evaluated using the HSC-ADC-EVALCZ high speed ADC data capture card in conjunction with the VisualAnalog data capture and analysis software. The SPIController software is used to configure the AD9261 and the AD9516 to the appropriate register settings.

### SOFTWARE

Manuals for VisualAnalog, the SPIController software, and the HSC-ADC-EVALCZ data capture hardware are included on the CD in the evaluation board package. It is recommended that the software be installed before connecting the hardware. VisualAnalog relies on the Microsoft .NET framework version 2, which is also included on the package CD. The .NET framework should be installed before installing VisualAnalog. The SPIController software should also be installed.

### HARDWARE

The AD9261 evaluation board and the HSC-ADC-EVALCZ data capture card are powered from a wall-connected switching power supply. The switching power supplies have different output voltages. Connect the 6 V power supply to the AD9261 evaluation board and the 5 V power supply to the HSC-ADC-EVALCZ data capture board. With the HSC-ADC-EVALCZ data capture board powered on and the VisualAnalog software installed, connect the USB cable to the PC and follow all the **Found new hardware** prompts, using the default driver each time.

### AD9261 SPI CONTROLLER

Upon successful software installation and hardware setup, start the AD9261 SPIController software. By default, the software recognizes the AD9261 evaluation board and loads the correct SPIController profile. If it does not, point the software to the following file: **AD9261\_16Bit\_10MSpiR03.cfg**.

The AD9261 SPIController has four tabs. When correctly configured, a message appears on the **CHIPID** subpane reporting that the AD9261 is interfaced (see Figure 6).



Figure 6. AD9261 SPIController

### AD9516 SPI CONTROLLER

Open another instance of the SPIController for control of the AD9516. If a box titled **Read Test Failure** appears, click **Ignore** to open the SPIController. This error occurs because the software has not been configured correctly to read from the chip. Use the following procedure to appropriately configure the SPIController to read and write to the AD9516.:

1. From the **File** menu, select **CfgOpen**; then select **AD9516spiengR03.cfg**.
2. When a **Calibration File Error!** message appears as shown in Figure 7, click **OK**.

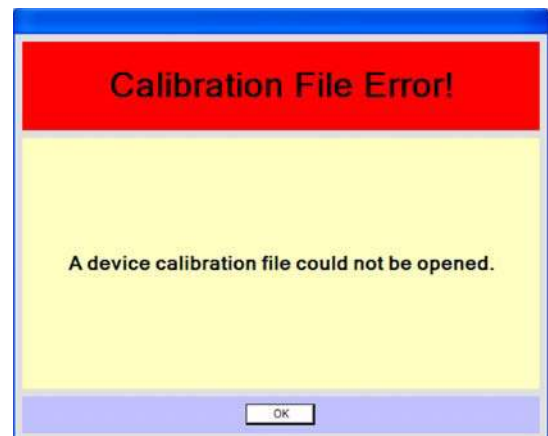

Figure 7.

3. Select **Config** and then **Controller Dialog** and make sure that **FIFO Chip Sel** is set to **2** and that **USB Chan #** is set to the same value as the AD9261 SPIController **Cfg** dialog (see Figure 8).

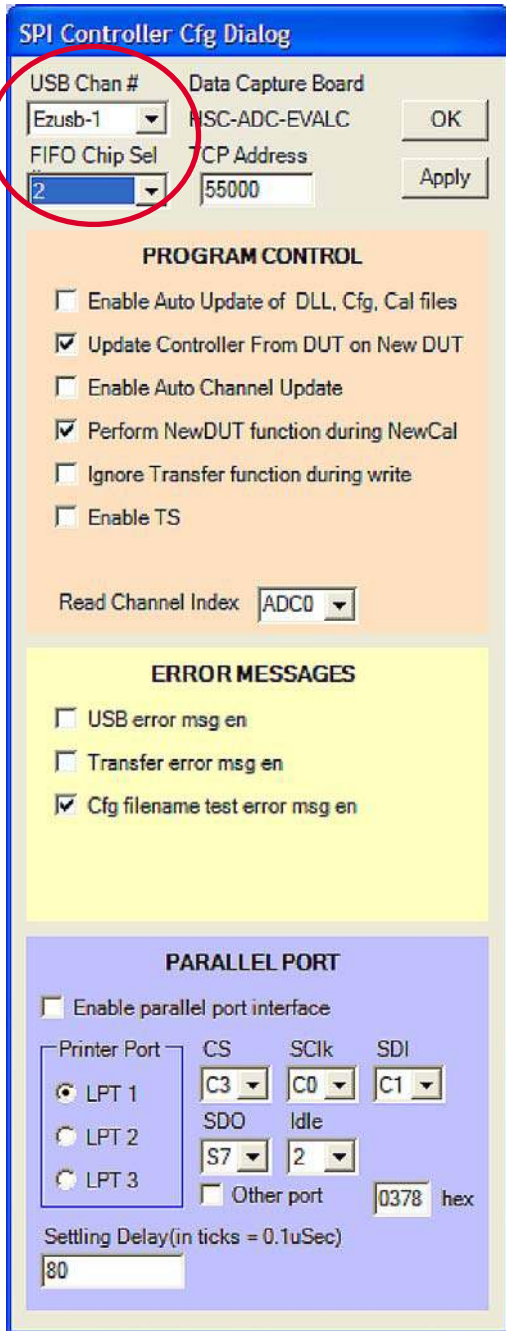

Figure 8.



Figure 9. AD9516 Configuration

The AD9516 register settings depend on the particular clock option chosen. Table 6 provides a list of register settings for some common crystal oscillators. The configuration shown in Figure 10 and Figure 11 is for the 122.88 MHz crystal oscillator.

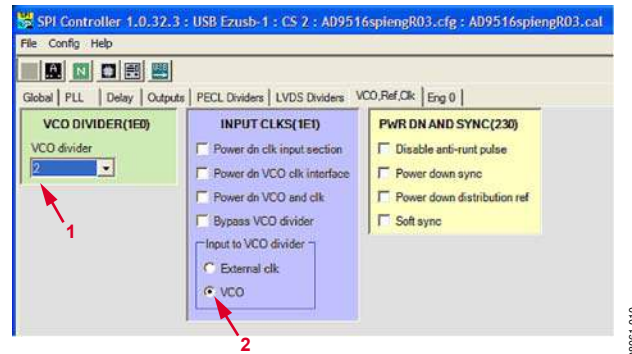

Figure 10. VCO and Clock Configuration for the 122.88 MHz Crystal Oscillator

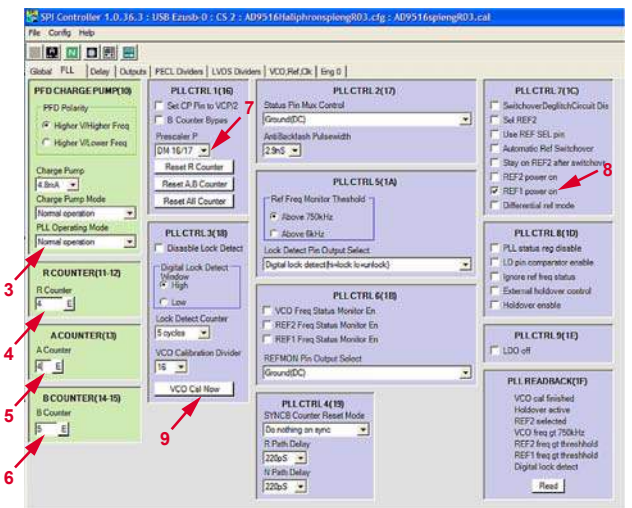

Figure 11. PLL Configuration for the 122.88 MHz Crystal Oscillator

**AD9516 REGISTER SETTINGS**

The SPIController uses a 4-wire interface; therefore, the AD9516 must be configured for this interface before any further writes can take effect. To configure the AD9516, check the **SDO Enable** bit, as shown in Figure 9,

Table 6. AD9516 Register Settings

Register	134.4 MHz	122.88 MHz	39.3216 MHz
VCO	2.688 GHz	2.580 GHz	2.595 GHz
R Divider	4	4	1
A/B Counter	0/5	4/5	2/4
Prescaler	16/17	16/17	16/17
Output CLK	672 MHz	645.12 MHz	648.81 MHz

**VisualAnalog OVERVIEW**

Open VisualAnalog and choose a canvas from the AD9261 folder (see Figure 12).

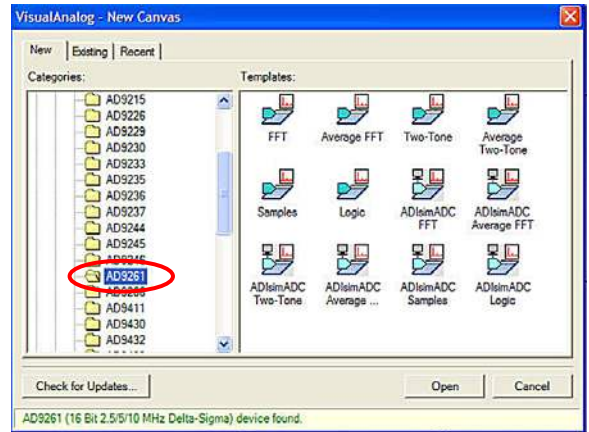

Figure 12. VisualAnalog Canvas

SCHEMATICS

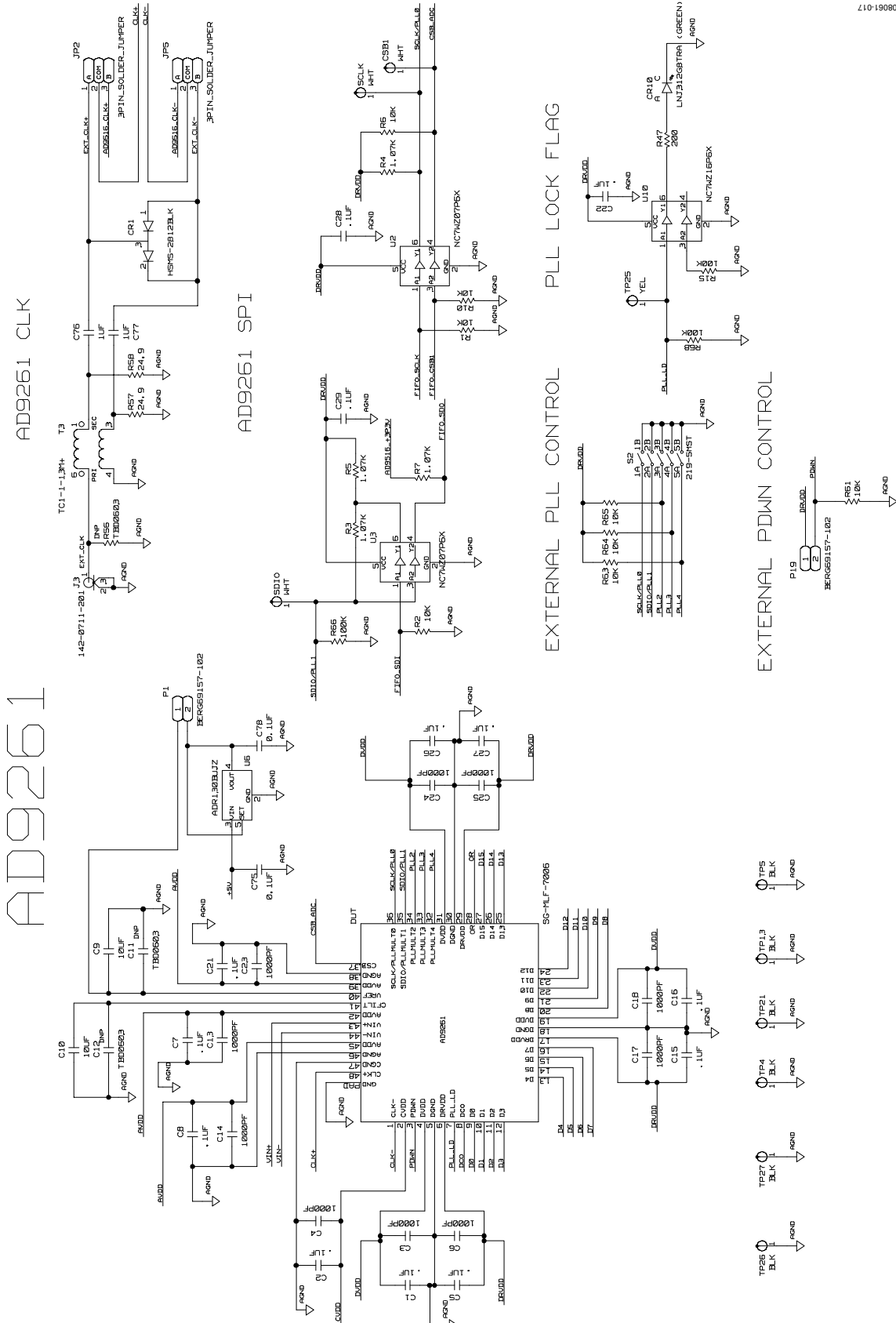

Figure 13.  
Rev. PrA | Page 8 of 20

110-1908



AD9261 INPUT

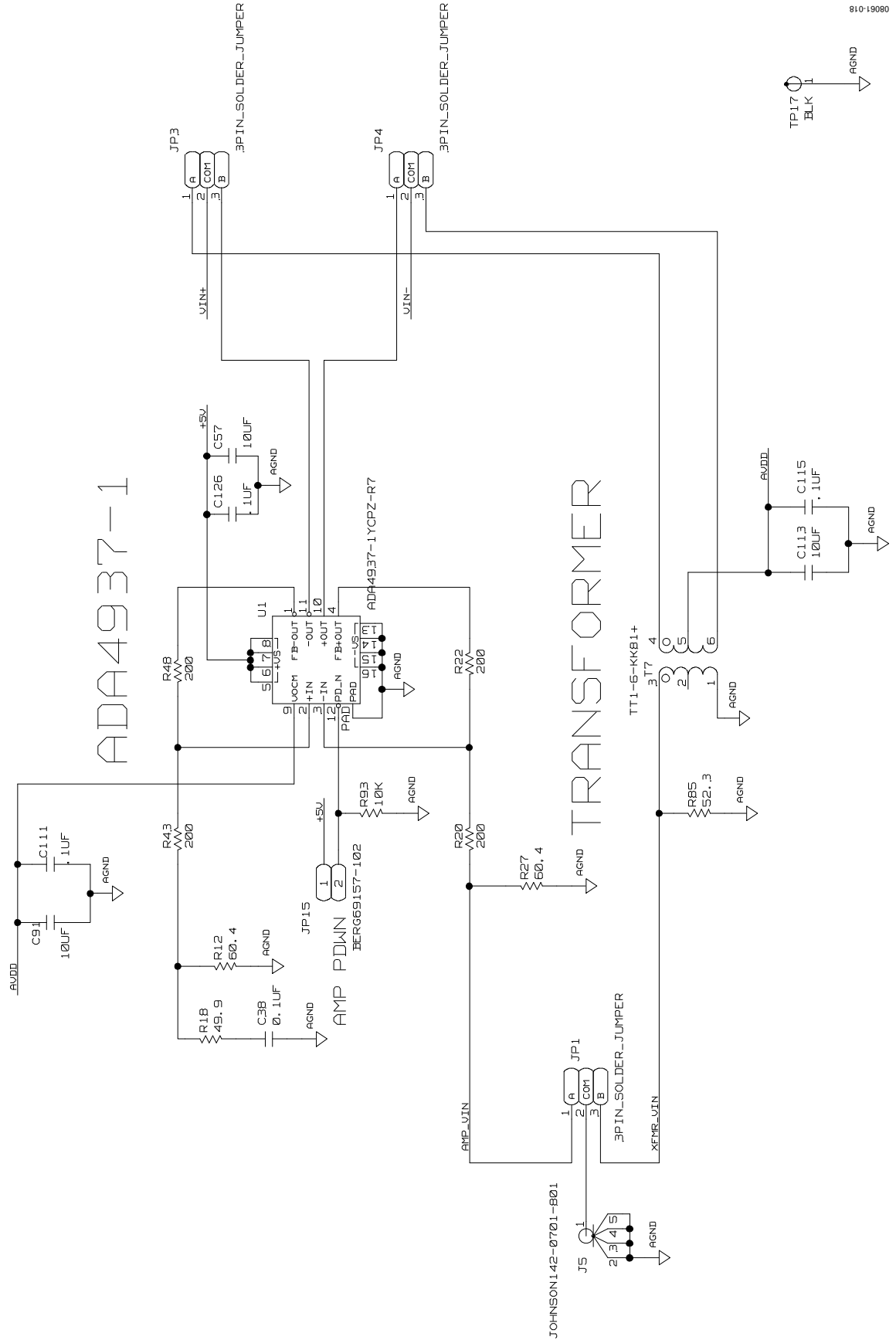

Figure 14.

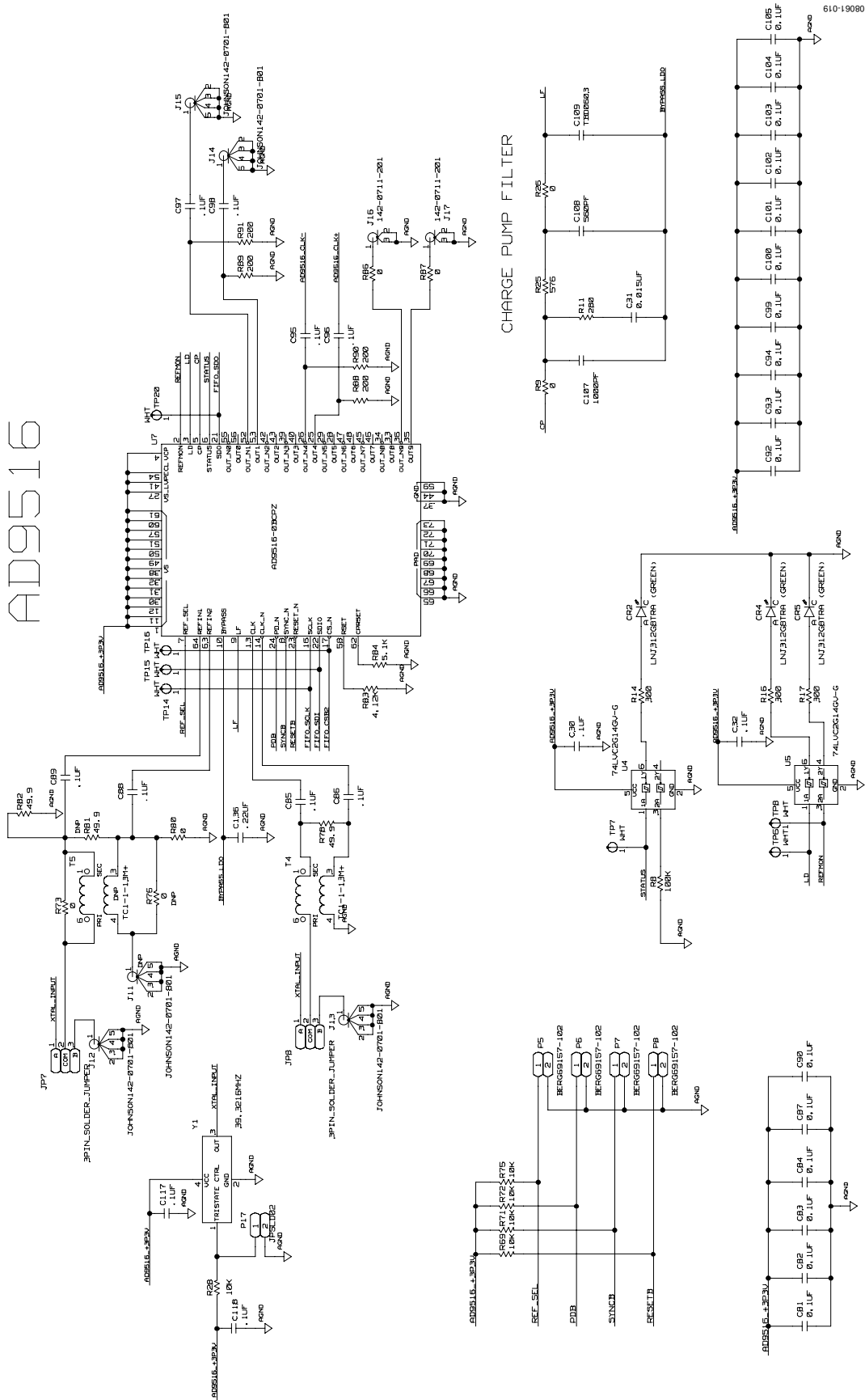

Figure 15.

FIFOS CONNECTOR

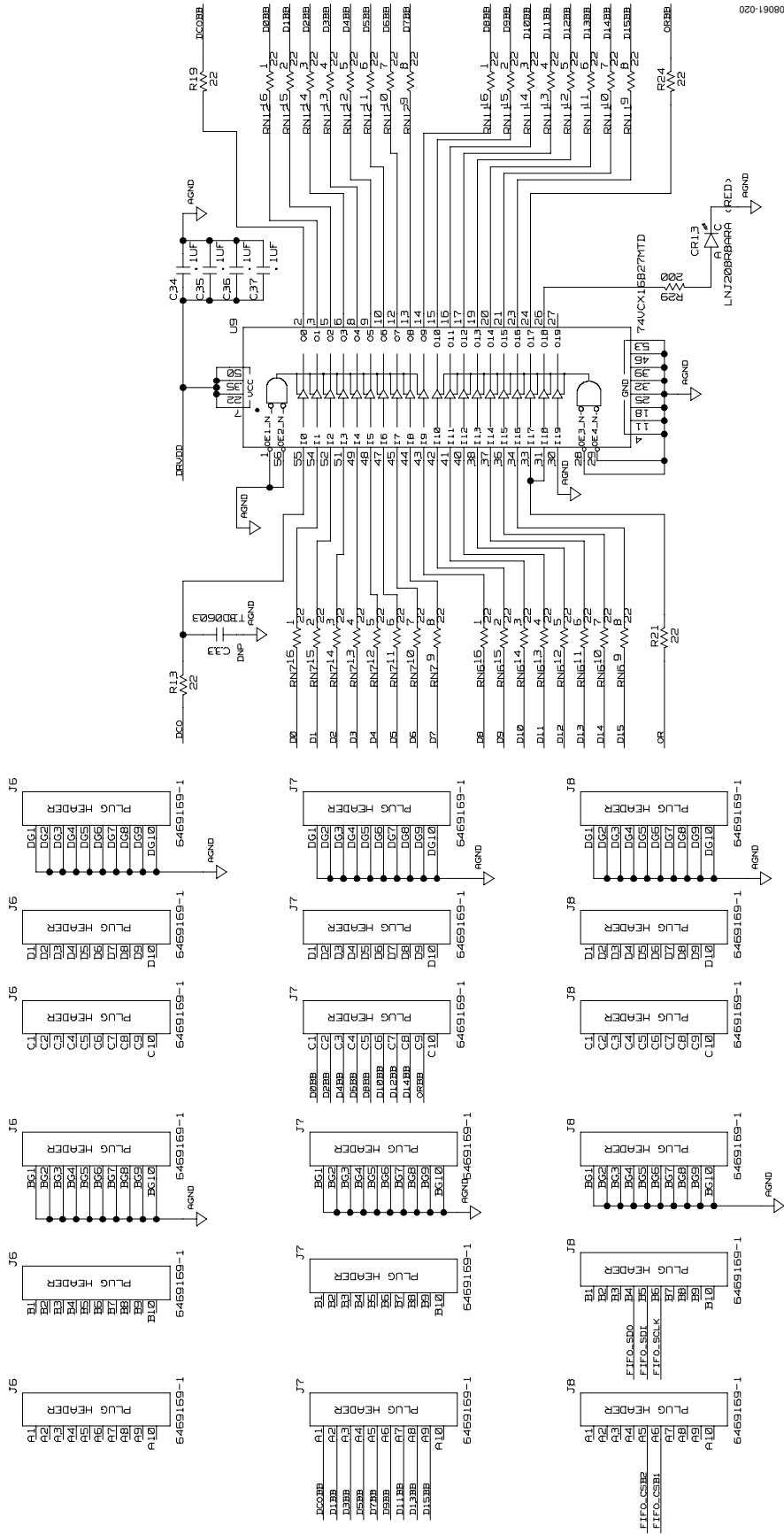

Figure 16.

POWER SUPPLY

AD9261

AVDD: +1.8V

CVDD: +1.8V

DVDD: +1.8V

DRVDD: +1.8V

AD9516-0: +3.3V

ADA4937-1: +5V

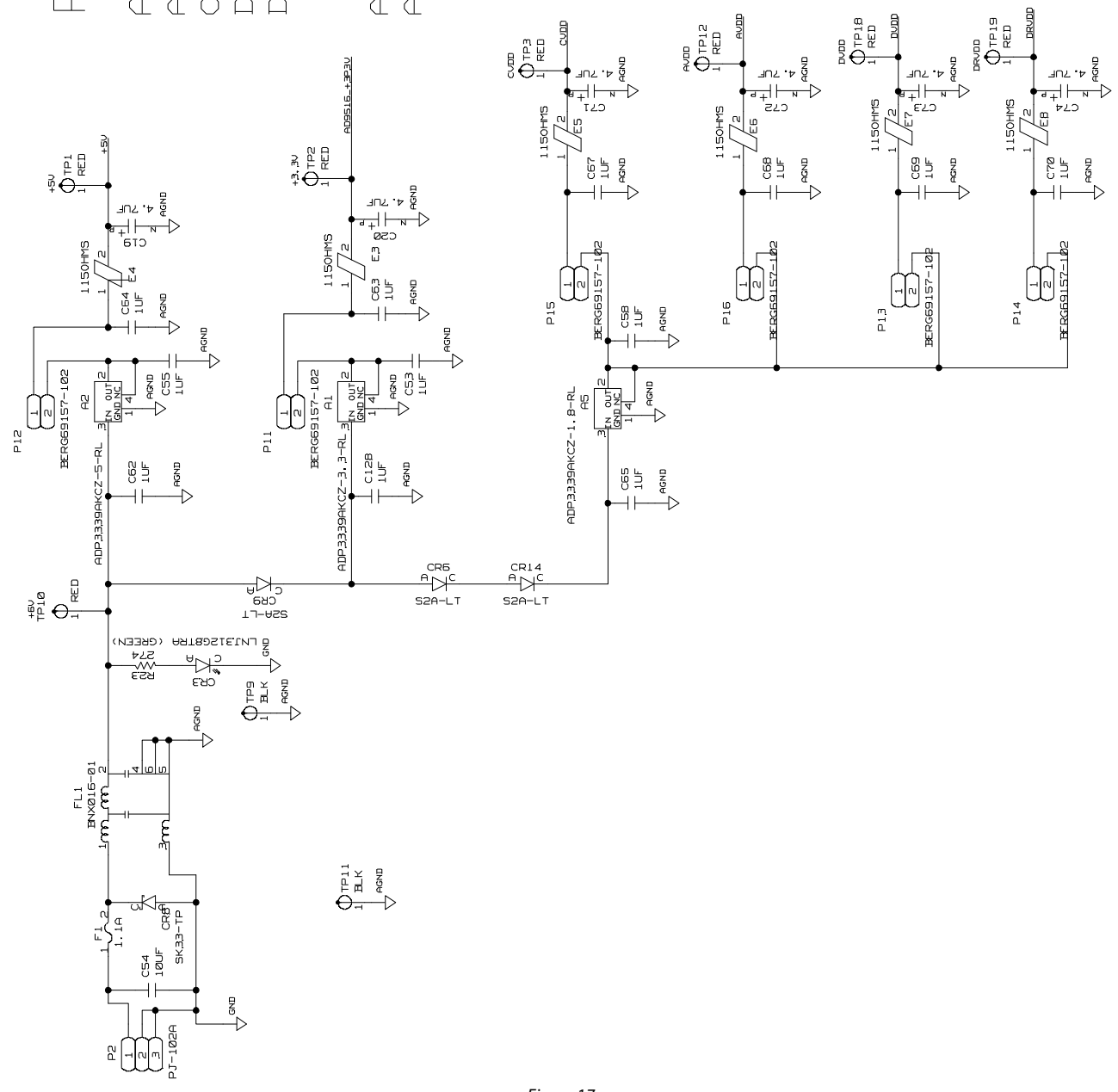

Figure 17.

LAYOUT

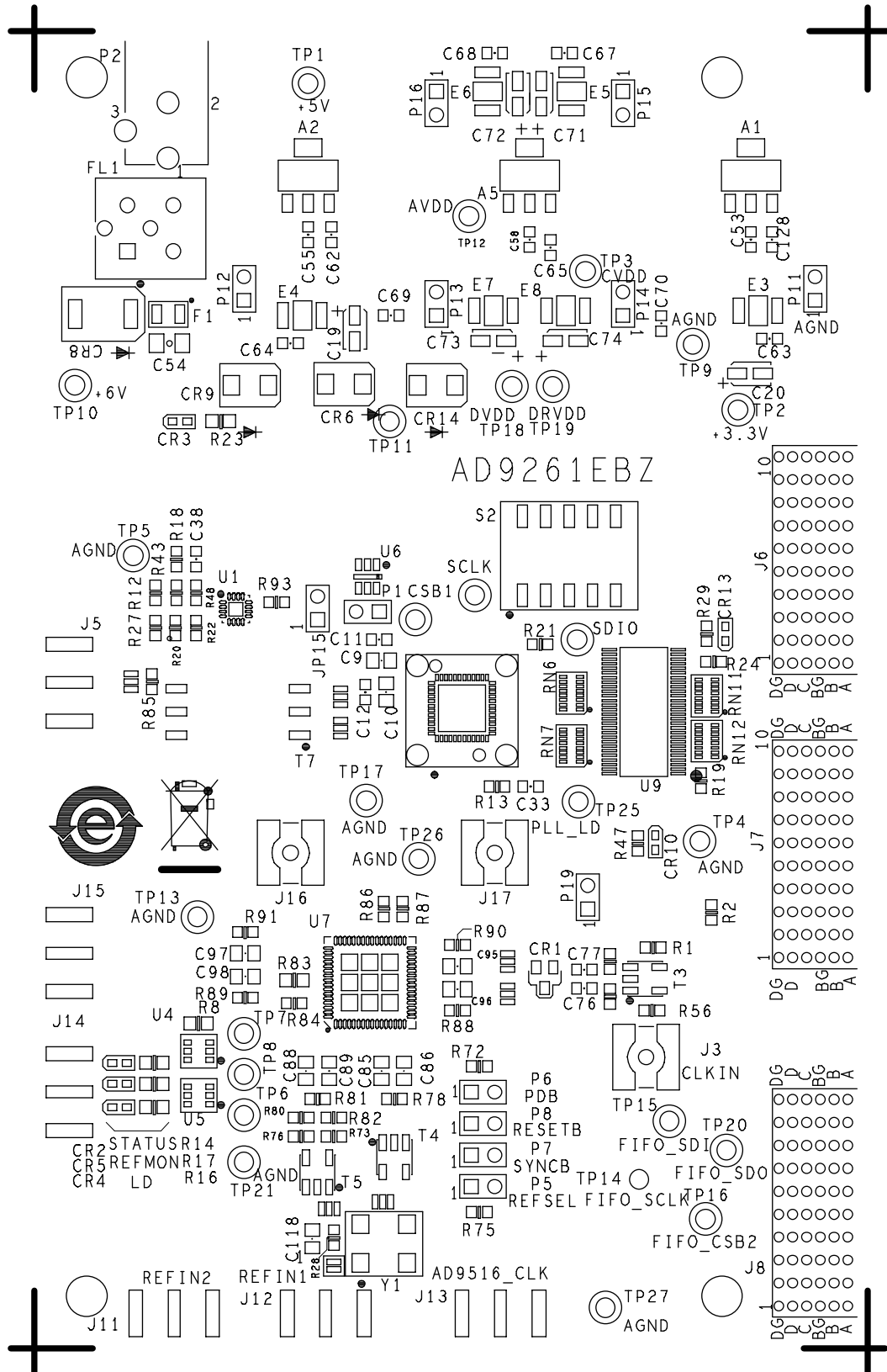

Figure 18. Top Silk

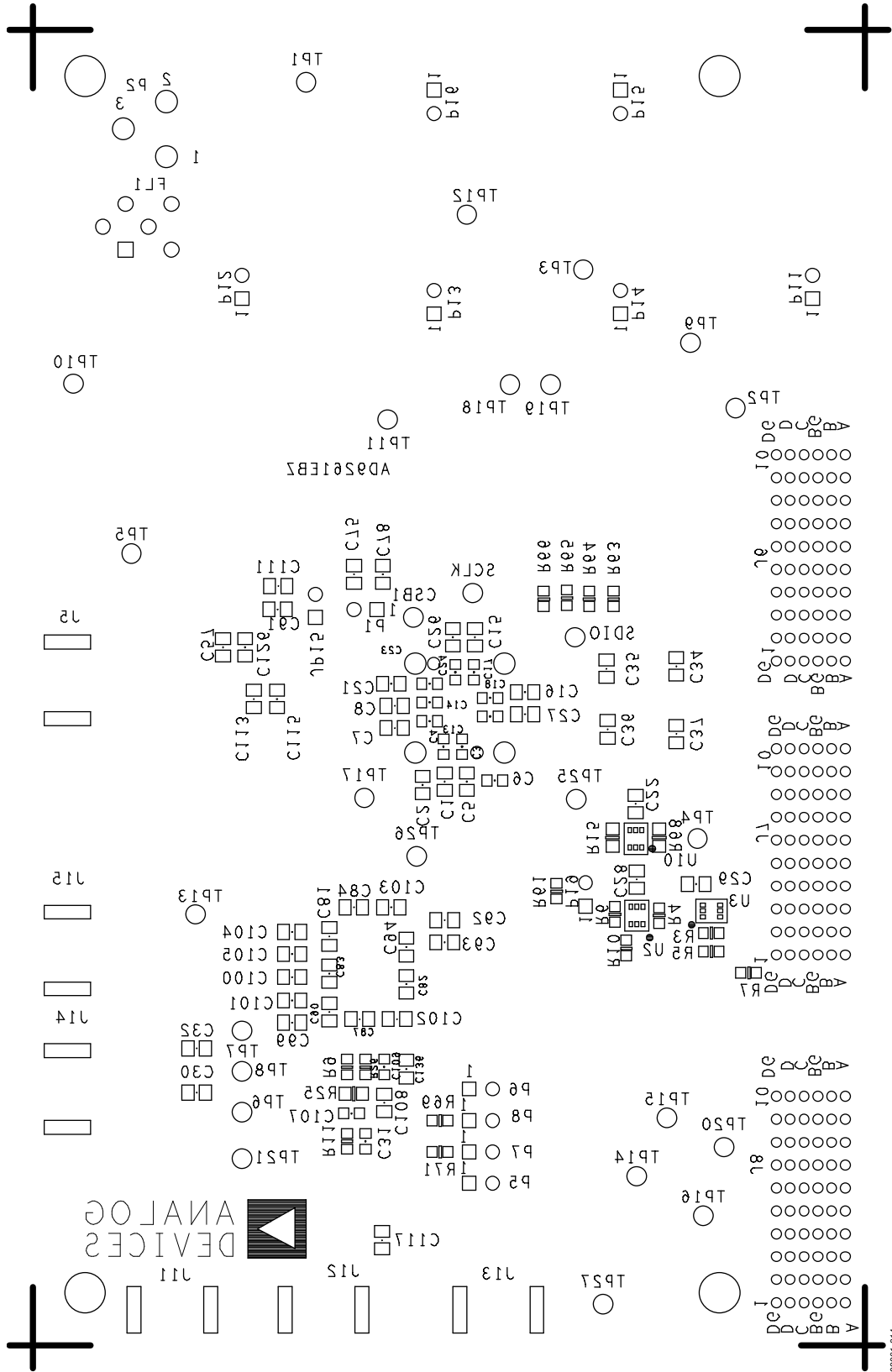

Figure 19. Bottom Silk

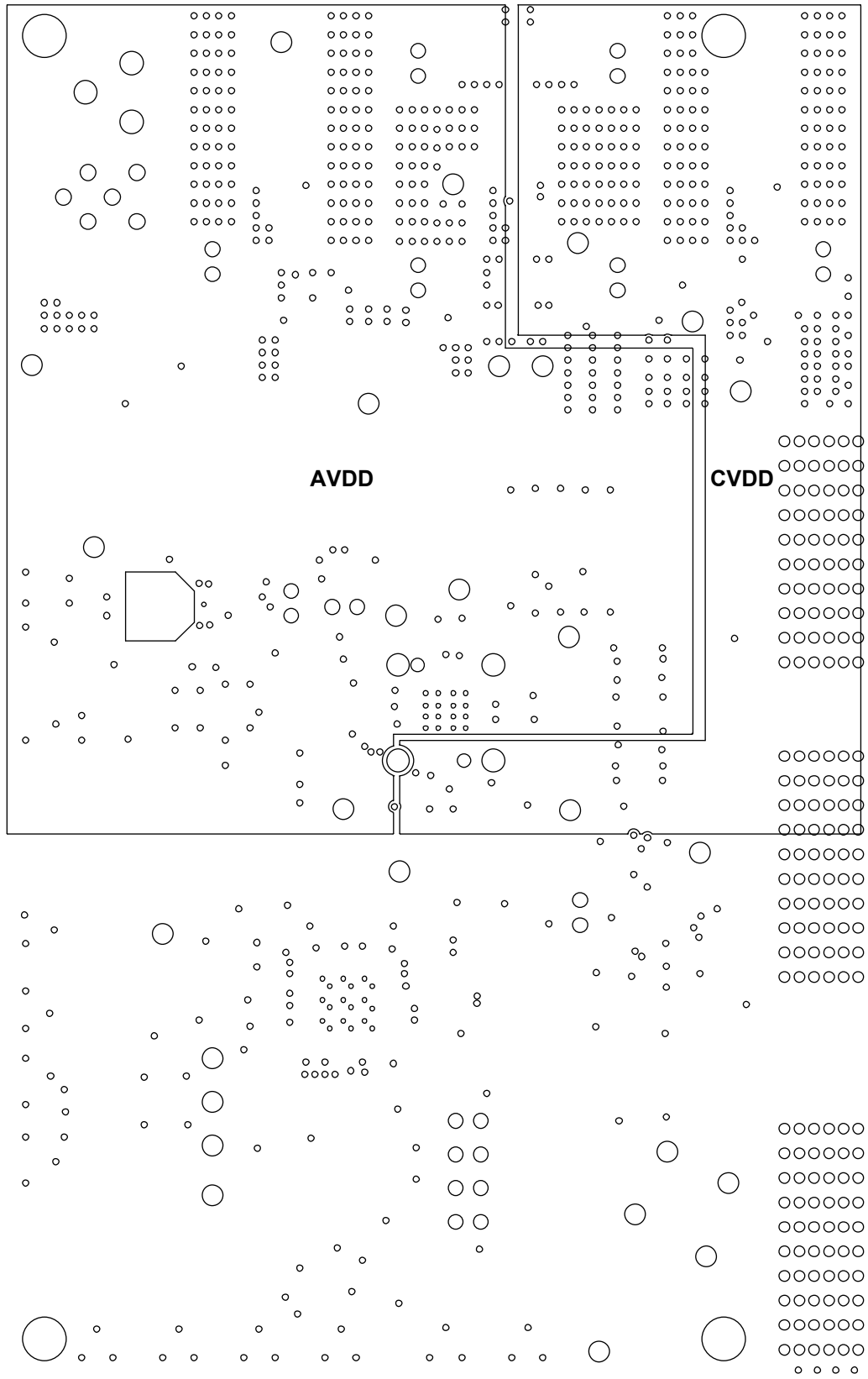

Figure 20. Power Layer 3

080061-015

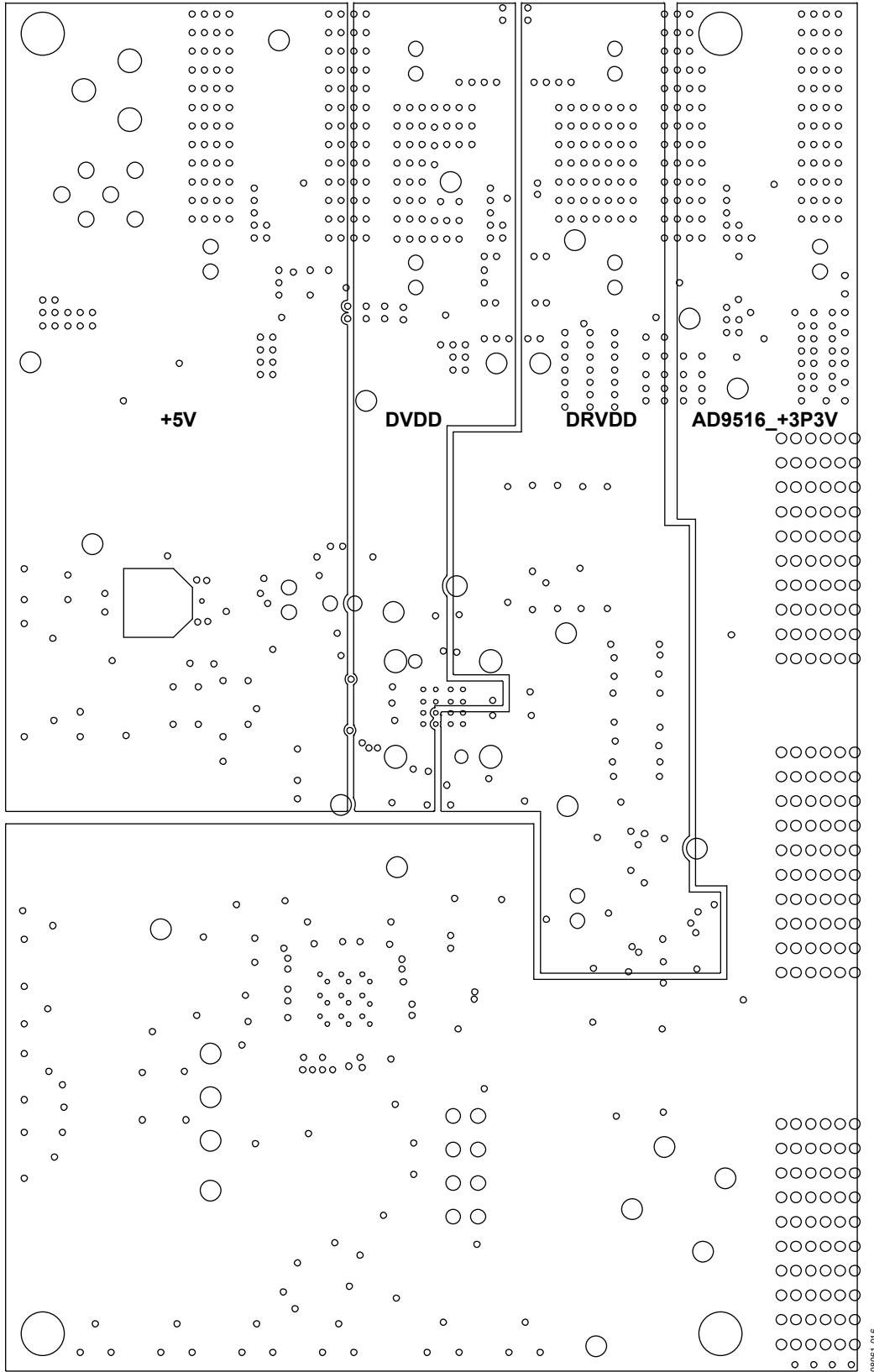

Figure 21. Power Layer 4

08061-016



## ORDERING INFORMATION

## BILL OF MATERIALS

Table 7.

Qty	Reference Designators	Description	Manufacturer	Manufacturer Part Number	Distributor and Part Number
1	A1		ADI	ADP3339AKCZ-3.3-RL	
1	A2		ADI	ADP3339AKCZ-5-RL	
1	A5		ADI	ADP3339AKCZ-1.8-RL	
32	C1, C2, C5, C7, C8, C15, C16, C21, C22, C26, C27, C28, C29, C30, C32, C34, C35, C36, C37, C85, C86, C88, C89, C95, C96, C97, C98, C111, C115, C117, C118, C126	CAP CER 0.10 $\mu$ F 25 V 10% X7R 0805	Murata Electronics North America	GRM21BR71E104KA01L	Digi-Key 490-1673-1-ND
2	C9, C10	CAP 10 $\mu$ F 6.3 V ceramic X5R 0805	Panasonic	ECJ-2FB0J106M	Digi-Key PCC2225CT-ND
18	C75, C78, C81, C82, C83, C84, C87, C90, C92, C93, C94, C99, C100, C101, C102, C103, C104, C105	CAP 0.10 $\mu$ F 50 V ceramic X7R 0805	Panasonic	ECJ-2YB1H104K	Digi-Key PCC1840CT-ND
11	C3, C4, C6, C13, C14, C17, C18, C23, C24, C25, C107	CAP 1000 pF 50 V ceramic X7R 0603 CAP 1000 pF 50 V ceramic 0603 SMD	Panasonic	ECJ-1VB1H102K ECU-V1H102KBV	Digi-Key PCC1772CT-ND Digi-Key PCC102BVCT-ND
1	C108	CAP 560 pF 50 V CERM chip 0805 SMD	Panasonic	ECU-V1H561JCX	Digi-Key PCC561CGCT-ND
0	C11, C12, C33, C109	0603; populated by default with 0 $\Omega$ and customer modifies as appropriate			
3	C57, C91, C113	CAP CER 10 $\mu$ F 10 V 10% X5R 0805	Murata	GRM21BR61A106KE19L	Digi-Key 490-1709-1-ND
14	C53, C55, C58, C62, C63, C64, C65, C67, C68, C69, C70, C76, C77, C128	CAP 1 $\mu$ F 6.3 V ceramic X5R 0603	Panasonic	ECJ-1VB0J105K	Digi-Key PCC1915CT-ND
1	C136	CAP 0.22 $\mu$ F 25 V ceramic X7R 0805	Panasonic	ECJ-2YB1E224K	Digi-Key PCC1832CT-ND
6	C19, C20, C71 to C74	CAP tantalum 4.7 $\mu$ F 16 V 10% SMD, 3216-18 A-case	AVX	TAJA475K016RNJ	Digi-Key 478-3868-1-ND
1	C31	CAP 15,000 PF 25 V CERM X7R 0603	Panasonic	ECJ-1VB1E153K	Digi-Key PCC1765CT-ND
1	C38	CAP 0.1 $\mu$ F 16 V ceramic X7R 0603	Panasonic	ECJ-1VB1C104K	Digi-Key PCC1762CT-ND
1	C54	CAP 10 $\mu$ F 16 V ceramic X5R 1206	Panasonic	ECJ-3YB1C106M	PCC2227CT-ND
1	CR1	Schottky diodes 20 VBR 1.2 pF	Avago Technologies	HSMS-2812-BLKG	Mouser 630-HSMS-2812-BLKG
5	CR2 to CR5, CR10	LED green TSS TYPE SMD 0603	Panasonic	LNJ312G8TRA	Digi-Key P11134CT-ND
1	CR13	LED red HI BRT SS type LO CUR SM 0603	Panasonic	LNJ208R8ARA	Digi-Key P524CT-ND
3	CR6, CR9, CR14	Rectifier SIL 2 A 50 V DO-214AA	Micro Commercial Components Corp	S2A-TP	Mouser 833-S2A-TP Digi-Key

Qty	Reference Designators	Description	Manufacturer	Manufacturer Part Number	Distributor and Part Number
					S2A-TPMSCT-ND
1	CR8	RECT SCHOTTKY 3 A 30 V DO-214AB	Micro Commercial Components Corp	SK33-TP	Digi-Key SK33-TPMSCT-ND
10	TP6, TP7, TP8, CSB1, SCLK, SDIO, TP14, TP15, TP16, TP20	Test point PC compact 0.063" D WHT	Keystone Electronics	5007	Digi-Key 5007K-ND
0	DUT	Not populated	Ironwood	SG-MLF-7006	
6	E3, E4, E5, E6, E7, E8	Bead core 4.5 × 3.2 × 1.8 SMD	Panasonic	EXC-CL4532U1	Digi-Key P9812CT-ND
1	F1	Polyswitch 1.10 A reset fuse SMD	Tyco Electronics	NANOSMDC110F-2	Digi-Key NANOSMDC110FCT-ND
1	FL1	FLTR EMI 50 MΩ 15 A 0.10 M to 1 GHZ	Murata	BNX016-01	Mouser 81-BNX016-01 Digi-Key 490-5055-ND
5	J5, J12, J13, J14, J15	CONN JACK end launch PCB 0.187" G	Johnson	142-0701-801	Mouser 530-142-0701-801 Digi-Key J502-ND
0	J11	Not populated	Johnson	142-0701-801	
3	J3, J16, J17	CONN SMA jack RCPT VERT gold SMD	Johnson	142-0711-201	Mouser 530-142-0711-201 Digi-Key J819-ND
3	J6, J7, J8	Z-pack connectors HDR 4X010P R/A B-plane HMZD	Tyco	6469169-1	Mouser 571-6469169-1
7	JP1, JP2, JP3, JP4, JP5, JP7, JP8	Solder jumpers SLD03	N/A	N/A	
13	P1, P5, P6, P7, P8, P11, P12, P13, P14, P15, P16, P19, JP15	CONN header 2 POS 0.100 VERT gold	Molex Berg	22-10-2021 69157-102	Mouser 538-22-10-2021 Digi-Key WM2722-ND
13	P1, P5, P6, P7, P8, P11, P12, P13, P14, P15, P16, P19, JP15	SHUNT, ECON, PHBR 15 AU, black	Tyco Electronics Amp	382811-6	Mouser 571-382811-6 Digi-Key A26227-ND
0	P17	Not populated, JPSLD02	N/A	N/A	
1	P2	CONN jack power 2.1 mm PCB	CUI	PJ-102A	Digi-Key CP-102A-ND
13	R1, R2, R6, R10, R28, R61, R63, R64, R65, R69, R71, R72, R75	RES 10.0 kΩ 1/10 W 1% 0603 SMD	Panasonic	ERJ-3EKF1002V	Digi-Key P10.0KHCT-ND
1	R11	RES 280 Ω 1/10 W 1% 0603 SMD	Panasonic	ERJ-3EKF2800V	Digi-Key P280HCT-ND
2	R12, R27	RES 60.4 Ω 1/10 W 1% 0603 SMD	Panasonic	ERJ-3EKF60R4V	Digi-Key P60.4HCT-ND
4	R13, R19, R21, R24	RES 22 Ω 1/10 W 5% 0603 SMD	Yageo PHYCOMP	RC0603JR-0722RL 9C06031A22R0JLHFT	Digi-Key 311-22GRCT-ND

# Preliminary Technical Data

# AD9261EBZ

Qty	Reference Designators	Description	Manufacturer	Manufacturer Part Number	Distributor and Part Number
3	R14, R16, R17	RES 300 Ω 1/8 W 5% 0805 SMD	Panasonic	ERJ-6GEYJ301V	Digi-Key P300ACT-ND
3	R8, R15, R68	RES 100 kΩ 1/10 W 0.10% 0805 SMD	Panasonic	ERA-6YEB104V	Digi-Key P100KZCT-ND
3	R18, R78, R82	RES 49.9 Ω 1/10 W 1% 0603 SMD	Panasonic	ERJ-3EKF49R9V	Digi-Key P49.9HCT-ND
0	R81	Not populated, 0603	Panasonic	ERJ-3EKF49R9V	
9	R20, R22, R43, R47, R48, R88 to R91	RES 200 Ω 1/10 W 1% 0603 SMD	Yageo PHYCOMP	RC0603FR-07200RL 9C06031A2000FKHFT	Digi-Key 311-200HRCT-ND
1	R23	RES 274 Ω 1/8 W 1% 0805 SMD	Panasonic	ERJ-6ENF2740V	Digi-Key P274CCT-ND
1	R25	RES 576 Ω 1/8 W 1% 0805 SMD	Panasonic	ERJ-6ENF5760V	Digi-Key P576CCT-ND
7	R9, R26, R73, R80, R86, R87	RES zero Ω 1/10 W 5% 0603 SMD 0805???	Panasonic	ERJ-3GEY0R00V	Digi-Key P0.0GCT-ND
0	R76	Not populated, 0805	Panasonic	ERJ-3GEY0R00V	
1	R29	RES 200 Ω 1/10 W 1% 0603 SMD	Yageo	9C06031A2000FKHFT	Digi-Key P200HCT-ND
4	R3, R4, R5, R7	RES 1.07 kΩ 1/16 W 0.1% 0603 SMD	Susumu	RR0816P-1071-B-T5-04H	Digi-Key RR08P1.07KBCT-ND
0	R56	0603; populated by default with 0 Ω and customer modifies as appropriate			
2	R57, R58	RES 24.9 Ω 1/10 W 1% 0603 SMD	Panasonic	ERJ-3EKF24R9V	Digi-Key P24.9HCT-ND
1	R66	Thermistor NTC 100 kΩ 5% 0603	Visha/Dale	NTHS0603N01N1003JE	Digi-Key 541-1103-1-ND
1	R83	RES 4.12 kΩ 1/8 W 1% 0805 SMD	Panasonic	ERJ-6ENF4121V	Digi-Key P4.12KCCT-ND
1	R84	RES 5.1 kΩ 1/16 W 0.10% 0603 SMD	Panasonic	ERA-3YEB512V	Digi-Key P5.1KYCT-ND
1	R85	RES 52.3 Ω 1/10 W 1% 0603 SMD	Panasonic	ERJ-3EKF52R3V	Digi-Key P52.3HCT-ND
1	R93	RES 10 kΩ 1/16 W 0.1% 0603 SMD	Panasonic	ERA-3YEB103V	Digi-Key P10KYCT-ND
4	RN6, RN7, RN11, RN12	RES array 22 Ω 5% 8 RES SMD	Panasonic	EXB-2HV220JV	Digi-Key Y1220CT-ND
1	S2	Switch tape seal 5 POS SMD	CTS Corporation Electrocomponents	219-5MST	Digi-Key CT2195MST-ND
2	T3, T4	Transformer, RF, RoHS	Mini-Circuits	TC1-1-13M+	
0	T5	Not populated	Mini-Circuits	TC1-1-13M+	
1	T7	Transformer, RF, RoHS	Mini-Circuits	TT1-6-KK81+	
7	TP1, TP2, TP3, TP10, TP12, TP18, TP19	Test point PC compact 0.063" D red	Keystone Components Corporation	5005 TP-104-01-02	Digi-Key 5005K-ND
9	TP4, TP5, TP9, TP11, TP13, TP17, TP21, TP26, TP27	Black	Keystone Components Corporation	5006 TP-104-01-00	Digi-Key 5006K-ND
1	TP25	Yellow	Keystone Components Corporation	5009 TP-104-01-04	Digi-Key 5009K-ND
1	U1		ADI	ADA4937-1YCPZ-R7	
1	U10	IC buffer UHS dual SC70-6	Fairchild	NC7WZ16P6X	Mouser 512-NC7WZ16P6X Digi-Key NC7WZ16P6XCT-ND

Qty	Reference Designators	Description	Manufacturer	Manufacturer Part Number	Distributor and Part Number
2	U2, U3	IC buffer UHS dual OD OUT SC70-6	Fairchild	NC7WZ07P6X	Mouser/512-NC7WZ07P6X Digi-Key NC7WZ07P6XCT-ND
2	U4, U5	IC dual INV SCHMITT-TRIG SC74-6	NXP	74LVC2G14GV-G	AMERICA II
1	U6		ADI	ADR130BUJZ	
1	U7		ADI	AD9516-0BCPZ	
1	U9	IC buffer/ LDRIVER 20BIT 56TSSOP	Fairchild	74VCX16827MTD	Mouser 512-74VCX16827MTD
0	Y1	Not populated	Valpey Fisher	VFAC3	

**ORDERING GUIDE**

Model	Description
TBD	TBD

**ESD CAUTION**

**ESD (electrostatic discharge) sensitive device.** Charged devices and circuit boards can discharge without detection. Although this product features patented or proprietary protection circuitry, damage may occur on devices subjected to high energy ESD. Therefore, proper ESD precautions should be taken to avoid performance degradation or loss of functionality.