

REVISION RECORD				
REV	ECD	DESCRIPTION	DRFT	CHKD
△		DRAWING MODIFY	JAMYN 11/22/05	
△		DRAWING MODIFY	JAMYN 1/19/06	

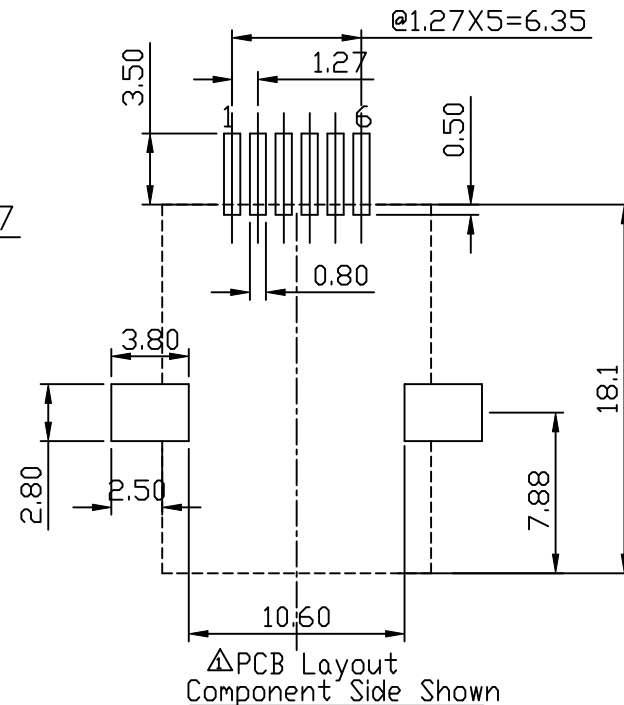
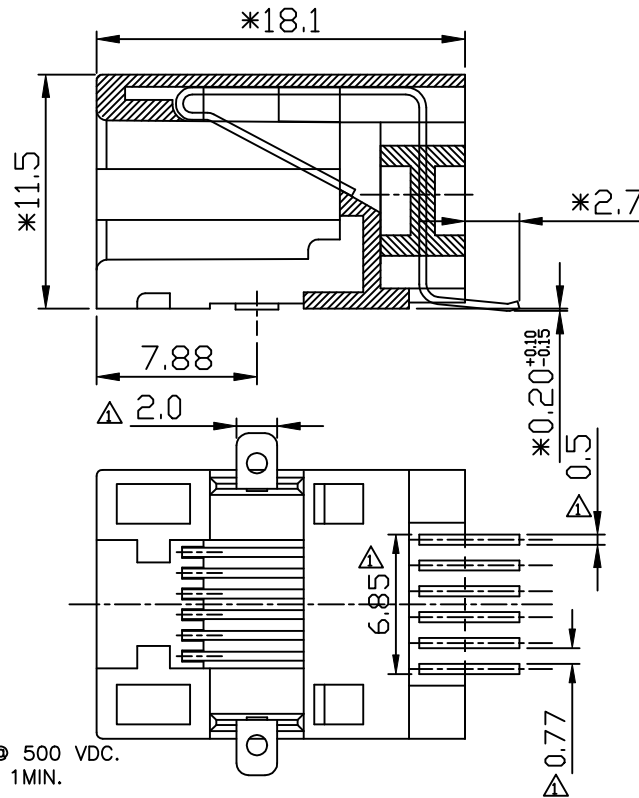
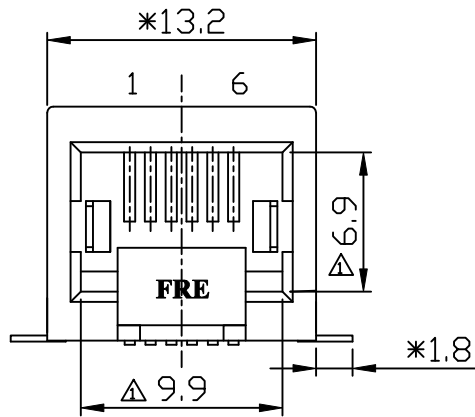

**NOTES:**

**ELECTRICAL:**

- VOLTAGE RATING : 125 VAC RMS.
- CURRENT RATING : 1.5 AMP.
- CONTACT RESISTANCE : 35 MILLIOHMS MAX.
- INSULATION RESISTANCE: 1000 MEGOHMS MIN @ 500 VDC.
- DIELECTRIC STRENGTH : 1000 VAC RMS 60Hz, 1MIN.

**MECHANICAL:**

- HOUSING MATERIAL : FR52 UL94V-0
- HOUSING COLOR : BLACK
- CONTACT MATERIAL : PHOSPHOR BRONZE t=0.35mm.
- PLATING : GOLD PLATING OVER NICKEL.
- OPERATING LIFE : 750 CYCLES MIN.
- PCB RETENTION PRE-SOLDER : 1 LBS MIN.
- PCB RETENTION POST-SOLDER: 10 LBS MIN.

**ENVIRONMENTAL:**

- STORAGE : -40°C TO +85°C.
- OPERATION: 0°C TO 70°C.
- IR REFLOW SOLDERING TEMPERATURE: 255°C TO 265°C (5-10 SECONDS).

MATES WITH MODULAR PLUG CONFORMING TO FCC PART 68, SUBPART F.

△ ROHS PART NUMBER: E536X-FX05YX-L

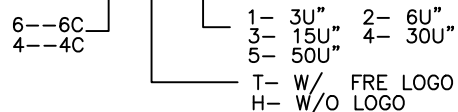

△ Cavities/reel	Pieces/reel	Pieces/carton
210	180	1800

DETACHED LISTS	MM (INCH)	DFTD CZH	DATE 01/31/02'	FULL RISE ELECTRONIC CO., LTD	
	TOLERANCES EXCEPT AS NOTED	CHKDASHNELLY	DATE 2006/1/22		
	MM	MFD	DATE	TITLE	
	.0 ± 0.20 ±	APPV LUSHENG	DATE 2006/1/22	SIDE ENTRY PCB JACK(SMT) 6P	
	.00 ± 0.15 ±	MATERIAL :		DRAWING NO. GE533058-LA	
.000 ± 0.075 ±	ANGLES ±	QTY :	/PART NO. SEE NOTE		
	THIRD ANGLE PROJECTION	FINISH:	SCALE : 3:1	DD NOT SCALE DRAWING	SHEET X OF Y