

REVISIONS				
P	LTR	DESCRIPTION	DATE	APP'D
E4		UPDATED VIEWS	21FEB2023	DP HW

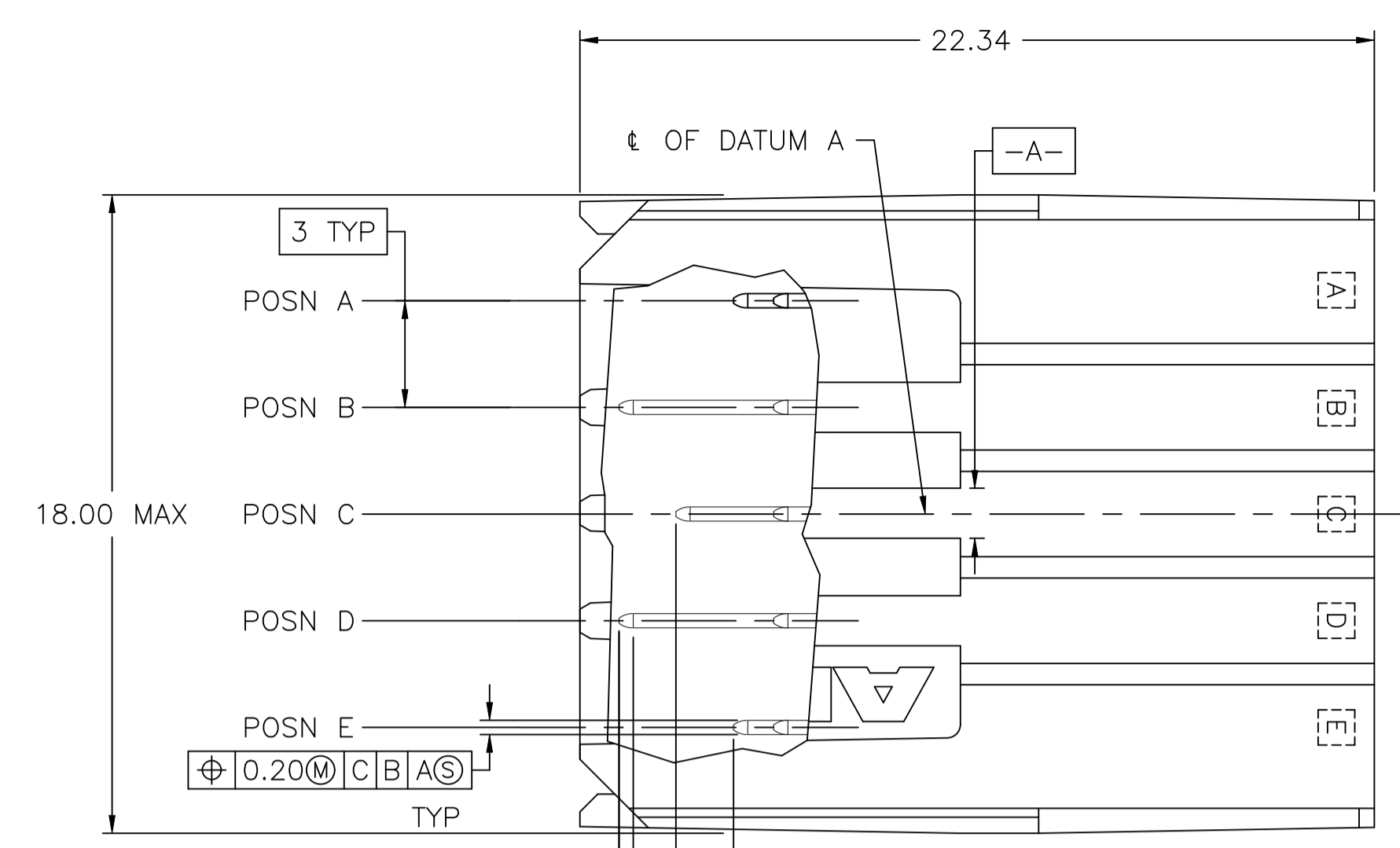

- 1 MATERIAL: HOUSING: POLYESTER, GRAY. UL 94V-0. CONTACT: HIGH CURRENT COPPER ALLOY.
- 2 FINISH: IN ACCORDANCE WITH PRODUCT SPECIFICATION 108-1651, GOLD PLATING OR EQUIVALENT PLATING ON PRODUCT CONTACT MATING AREA, AND MATTE TIN PLATING ON COMPLIANT PIN AREA, ALL OVER MATTE NICKEL UNDERPLATED. DETAIL PLEASE REFER TO PRODUCT SPECIFICATION 108-1651.
- 3 FINISH: CONTACT LUBRICATION WITH BELLCORE APPROVED LUBRICANT. TECHNICAL REFERENCE: GR-1217-CORE, ISSUE 1, NOVEMBER 1995.
- 4 10.26±0.13 DIMENSION APPLIES IN THIS AREA.
- 5 REFERENCE APPLICATION SPEC 114-1103 FOR RECOMMENDED PLATED THRU HOLE DIAMETER AND PLATING THICKNESSES.
- 6. CURRENT RATING 16A/CONTACT PER PRODUCT SPEC 108-1651.

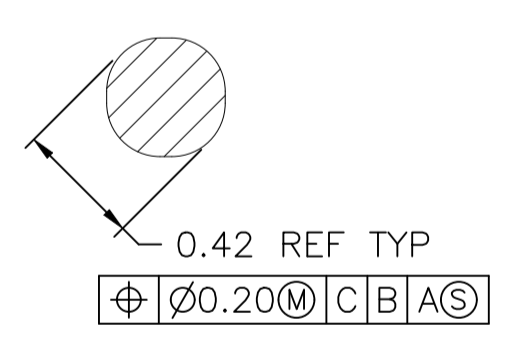
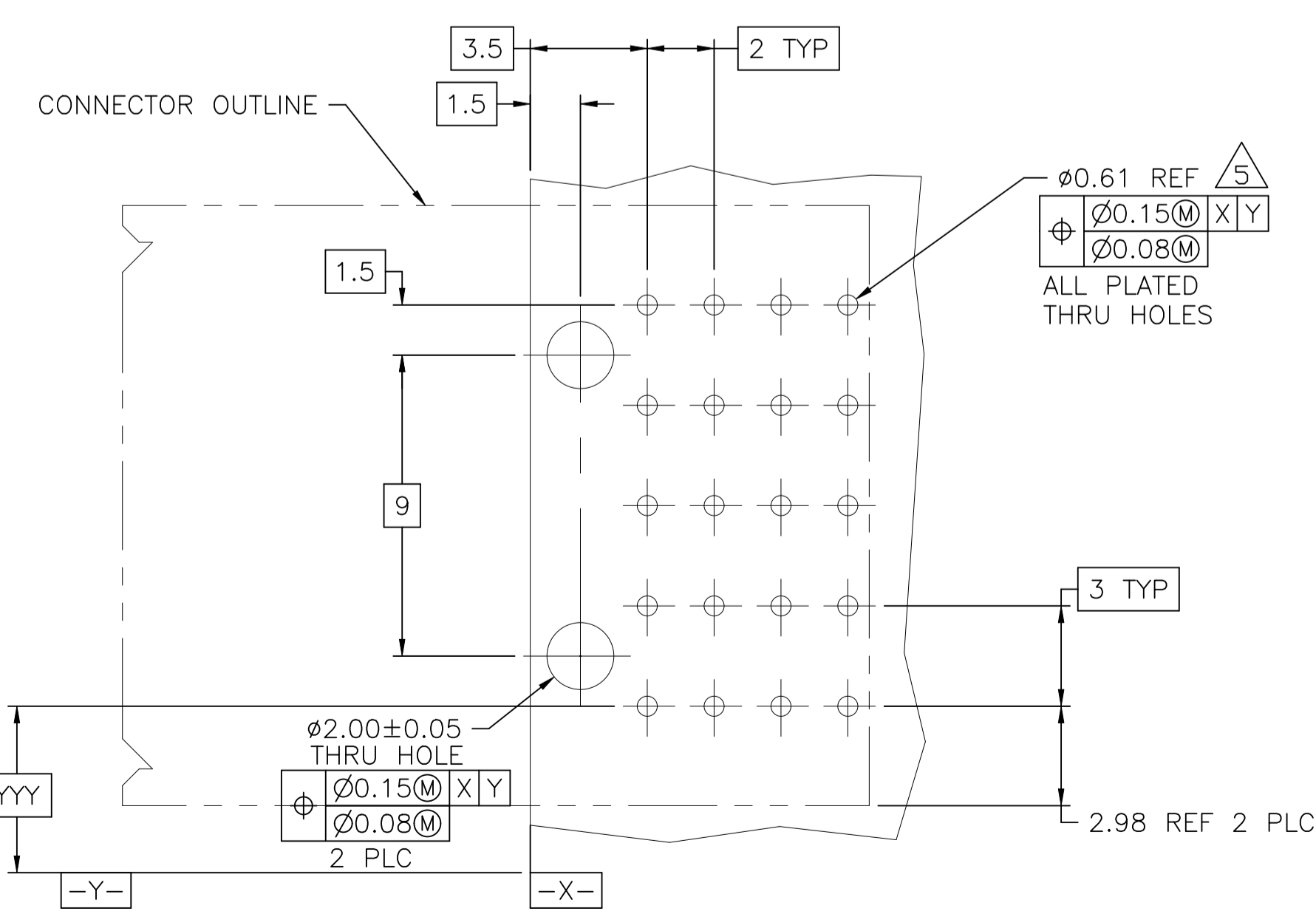
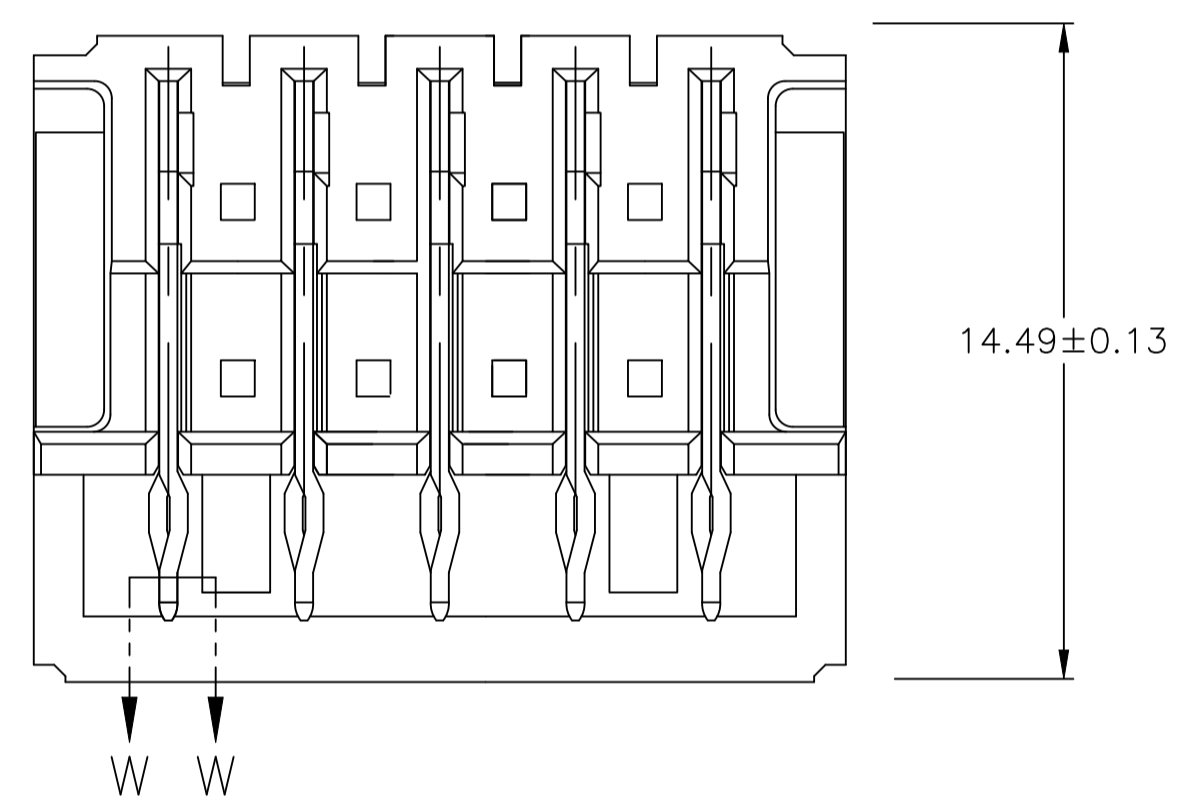
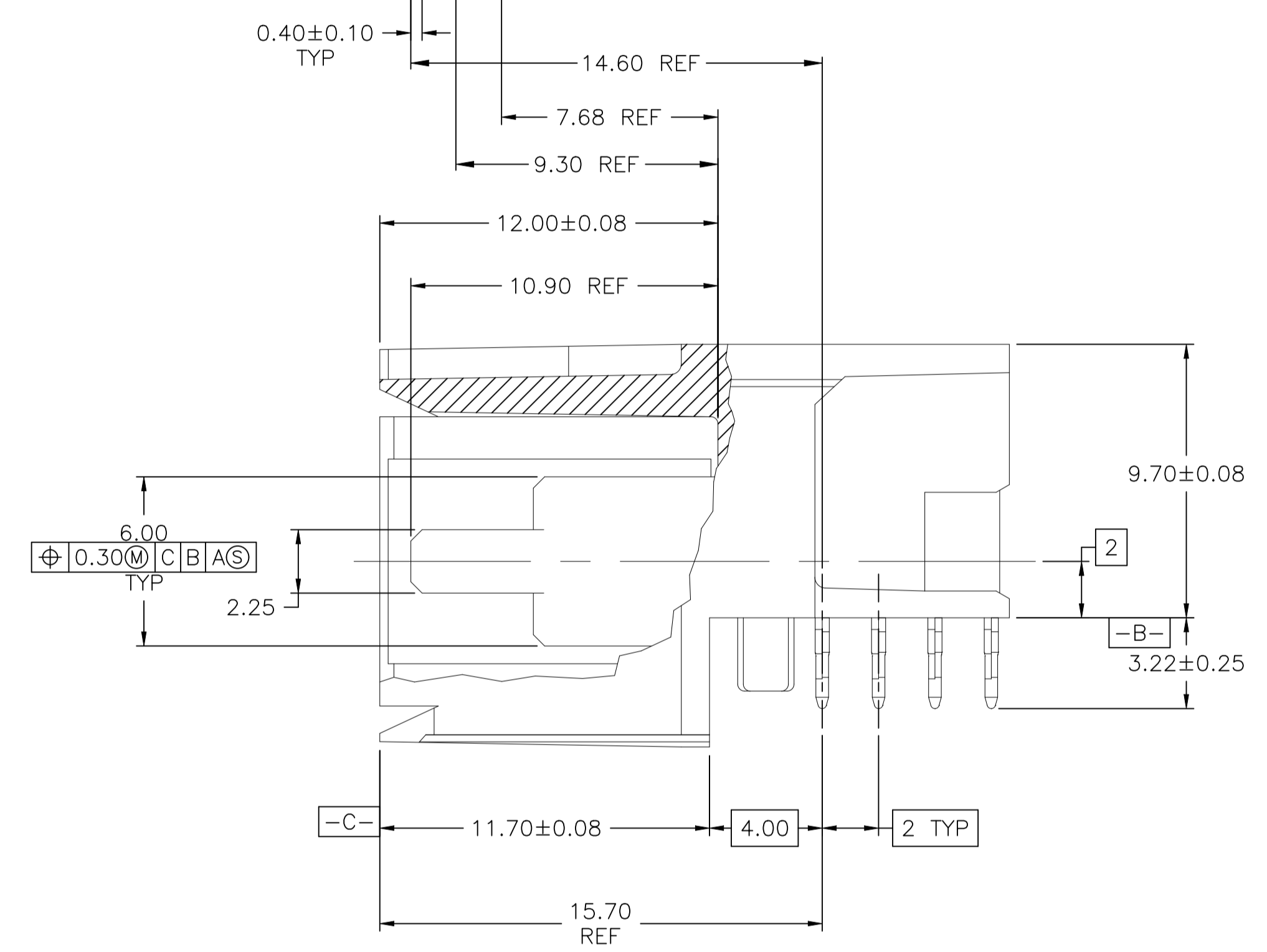
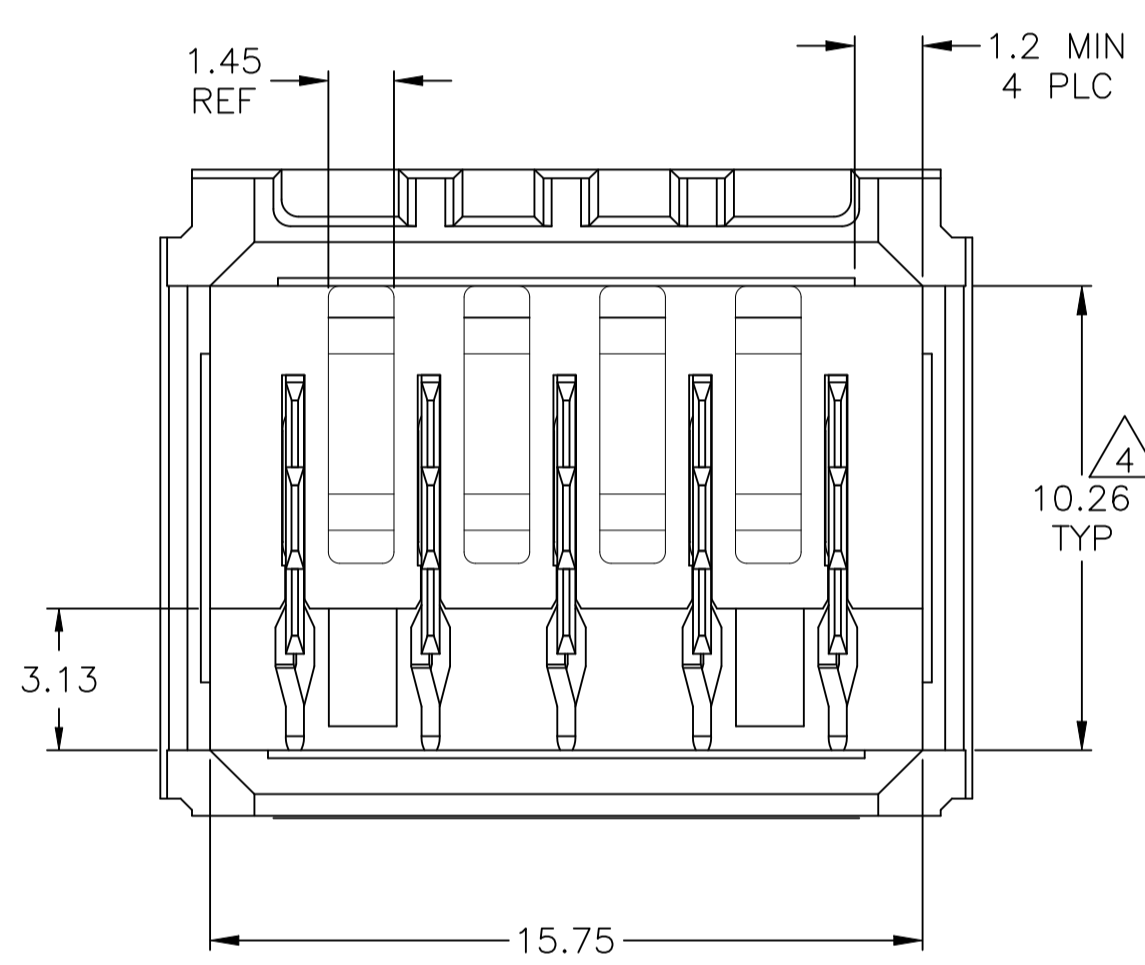

SECTION W-W
SCALE 40:1

PLC	POSITIONS	CONTACTS	NUMBER OF LOADED POSITIONS	PART NUMBER
-	B, D	A, C, E	5	120955-3
A, B, D, E	C	-	5	120955-2
-	A, B, C, D, E	-	5	120955-1
POSITIONS LOADED WITH 9.30 REF CONTACTS	POSITIONS LOADED WITH 10.90 REF CONTACTS	POSITIONS LOADED WITH 7.68 REF CONTACTS	NUMBER OF LOADED POSITIONS	PART NUMBER

THIS DRAWING IS A CONTROLLED DOCUMENT.

DIMENSIONS: mm	TOLERANCES UNLESS OTHERWISE SPECIFIED:	DWG: B.CARRO 140CT04	CHK: R.PATTERSON 140CT04	APP'D: R.PATTERSON 140CT04	NAME: R.PATTERSON
0 PLC ± -	1 PLC ± -	2 PLC ± 0.13	3 PLC ± -	4 PLC ± -	ANGLES ± -
MATERIAL	FINISH	WEIGHT	SIZE	CAGE CODE	DRAWING NO
1	2 3	0.000000	A1	00779	120955
CUSTOMER DRAWING			SCALE	SHEET	REV
			6:1	1 of 1	E4

TE Connectivity
ASSEMBLY, RIGHT ANGLE HEADER, W/ RETENTION PEGS, UNIVERSAL POWER MODULE