

THIS DRAWING IS UNPUBLISHED. RELEASED FOR PUBLICATION ,19 .
 © COPYRIGHT 19 BY AMP INCORPORATED. ALL RIGHTS RESERVED.

LOC	DIST	REVISIONS					
		P	LTR	DESCRIPTION	DATE	DWN	APVD
G	14		D	REV / 0L20-0197-97	21AUG97	ME	SB

AMP WIRE RANGE	UL E13288	SR LR7189 Certified
12-10 AWG SOLID OR STRANDED	12-10 AWG SOLID OR STRANDED	12-10 AWG SOLID OR STRANDED

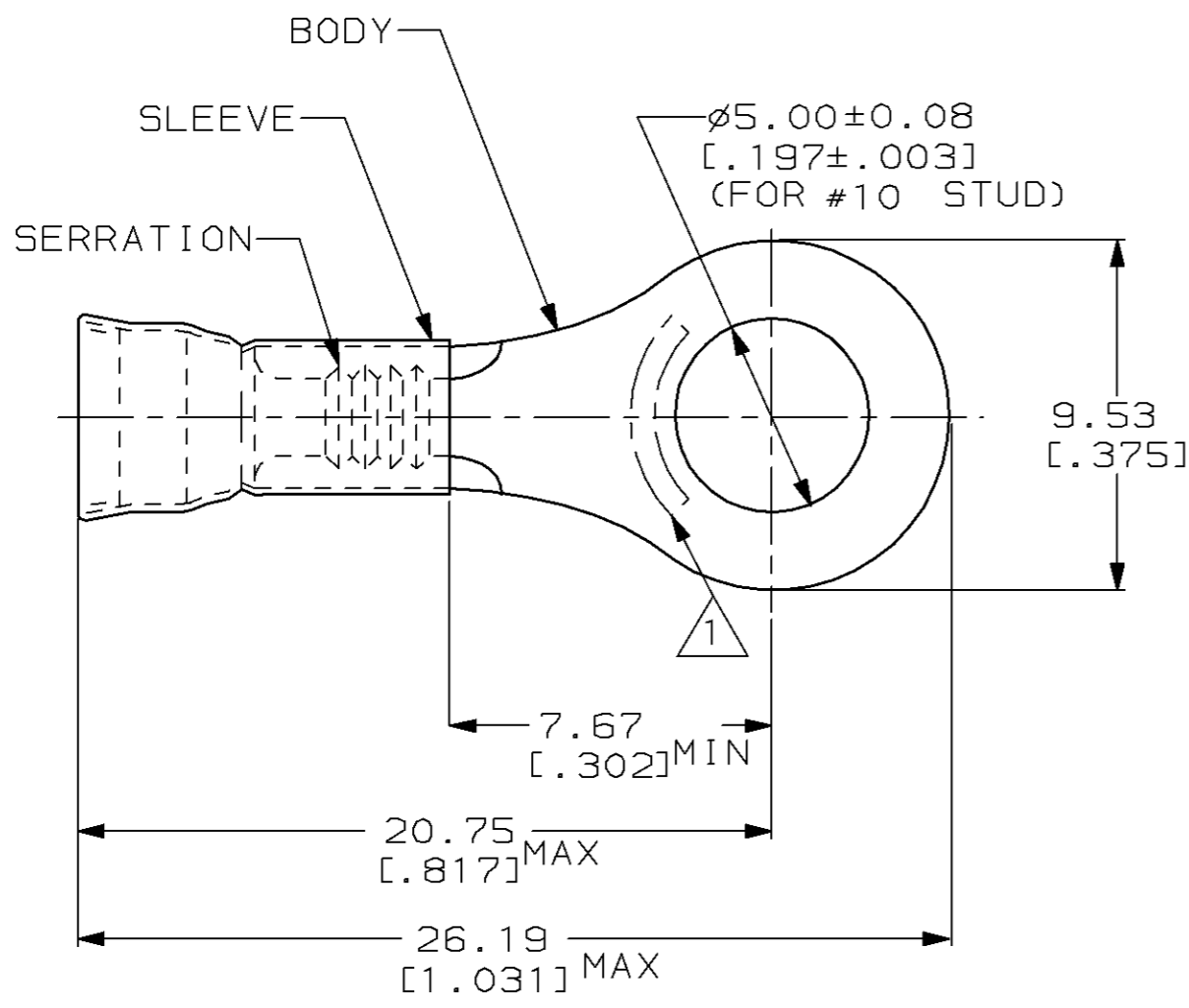

- 1 STAMP AMP 12-10* LOCATE APPROX AS SHOWN
- 2 WIRE INSUL DIA, 3.81-5.84 [0.150-.230]
- 3 TONGUE MATL THK, 0.99 ± 0.05 [0.039 ± 0.002]

2500	ON TAPE, REEL	2-31771-1
500	LOOSE PIECE	31771
QTY	PACKAGE TYPE	PART NO

AMP INCORPORATED
CUSTOMER SERVICE SYSTEM

FOR ADDITIONAL PRODUCT INFORMATION OR COPIES OF DRAWINGS AND TECHNICAL DOCUMENTS: PRODUCT INFORMATION CENTER 1-800-522-6752

FOR APPLICATION TOOLING INFORMATION: TOOLING ASSISTANCE CENTER 1-800-722-1111

FOR ORDER ENTRY: 1-800-526-5142

MAX RECOMMENDED OPERATING TEMPERATURE:
 170°C [338°F]

VOLTAGE RATING:
 -

CIRCULAR MIL AREA:
 2.62mm²-6.64mm² [5180-13100]

THIS DRAWING IS A CONTROLLED DOCUMENT FOR AMP INCORPORATED. IT IS SUBJECT TO CHANGE AND THE CONTROLLING ENGINEERING ORGANIZATION SHOULD BE CONTACTED FOR THE LATEST REVISION.

DIMENSIONS: mm [in]

TOLERANCES UNLESS OTHERWISE SPECIFIED:

0 PLC	±-
1 PLC	±-
2 PLC	±0.20 [0.008]
3 PLC	±-
4 PLC	±-
ANGLES	±-

MATERIAL: BODY, CU, SLV, CU PER ASTM B152

FINISH: TIN PLATE PER ASTM B 545

DWN	L OLMEDA	23JAN95	AMP AMP Incorporated Harrisburg, PA 17105-3608
CHK	M ELLIS	23JAN95	
APVD	S BORTNER	23JAN95	
PRODUCT SPEC	UL486A		
APPLICATION SPEC	-		NAME: TERMINAL, RING, DIAMOND GRIP™, WIRE SIZE, 12-10 AWG
WEIGHT	-		SIZE: A3 CAGE CODE: 00779 DRAWING NO: C-31771
CUSTOMER DRAWING			SCALE: 6:1 SHEET: 1 OF 1 REV: D