

Product Facts

- Standard options: short circuit/overload protection and control status.
- Optically coupled all solid state relay.
- TTL & CMOS compatible input.
- Low on-resistance power MOSFET output.
- Tested per MIL-PRF-28750D and approved to DSCC drawing 90091.
- All versions available with Tyco Electronics "W" level screening for CII relays.

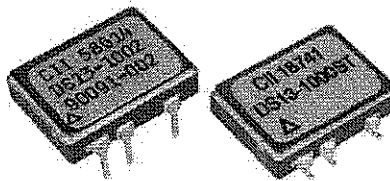

DS13 series SSRs employ state of the art photo-voltaic optical isolation and power MOSFET output chips for ultra-reliable high speed switching of DC loads up to 2 amps, with low on-resistance. Standard options include integral current overload/short circuit

protection and a separate input control status line. The overload feature provides protection of the relay, load and load circuit wiring in the event of a sustained current overload or short circuit while the relay is on or when it is turned on into a short. The control

status provides a built-in test function which provides a logic "0" when the input circuit is energized and functional. The relay is packaged into a custom hermetically sealed low-profile 8-pin ceramic DIP package, with through hole or surface mount pins.

CII Part No.	DSCC Dwg. No.	Relay Version
DS13-1Y	90091-008	Basic relay
DS13-1000	90091-004	Relay w/ short circuit protection
DS13-1001	90091-006	Relay w/ control status
DS13-1002	90091-002	Relay w/ short circuit protection and control status

Notes: Add suffix "S" to part number for surface mount versions.
Add suffix "T" to part number for tinned leads.
Add suffix "W" to part number for lower screening level.

2 Terminal Input Configuration

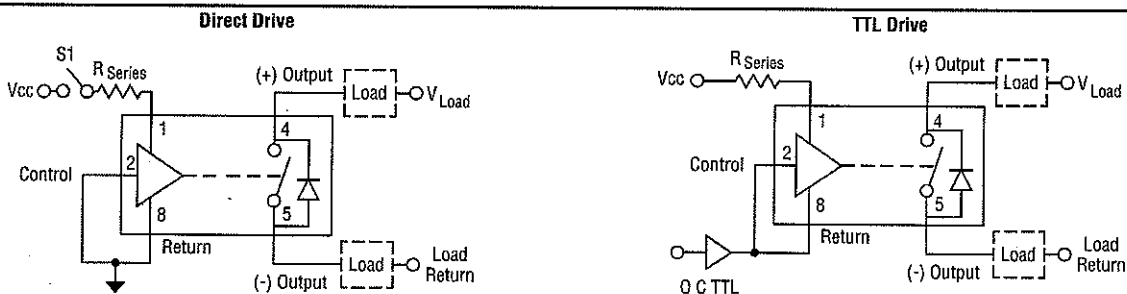

3 Terminal Input Configuration

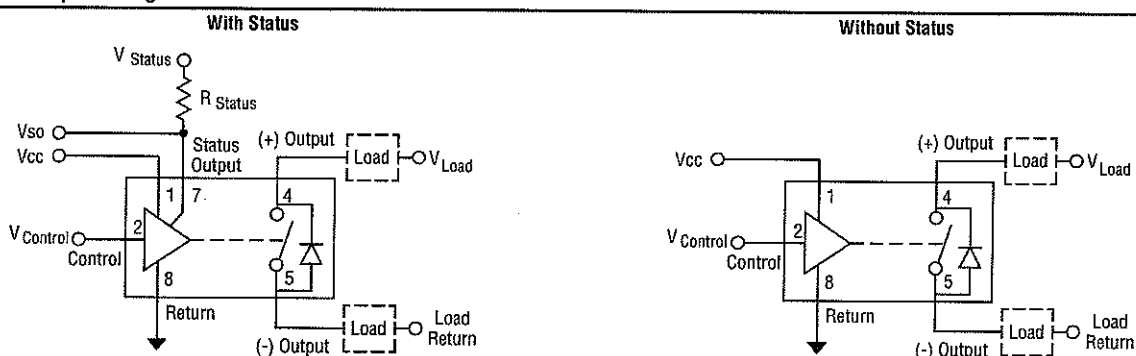

© 2008 by Tyco Electronics Corporation. All Rights Reserved.
CII, TE Logo and Tyco Electronics are trademarks.

DS13 SSR for loads up to 2A @ 60Vdc (Continued)

Environmental Characteristics
Ambient Temperature Range:

 Operating: -55°C to +105°C.
 Storage: -55°C to +125°C.

Vibration Resistance:

100 G's, 10-3,000 Hz.

Shock Resistance:

1,500 G's, 0.5 ms pulse.

Constant Acceleration Resistance:

5,000 G's.

Mechanical Characteristics
Weight (max.):

.07 oz. (2 grams)

Materials:

 Case: DIP, hermetically sealed,
 ceramic
 Pins: Copper, gold plated

Electrical Specifications (-55°C to +105°C unless otherwise specified)
Input (2 terminal configuration)

Input supply voltage range (Vcc)	3.8 - 32 Vdc (Notes 1 & 2, Figures 1 & 2)
Input current (max.) @ 5Vdc	15mA _{dc} (Notes 1 & 2, Figures 1 & 2)
Must turn-on voltage	3.8Vdc
Must turn-off voltage	1.5Vdc
Reverse voltage protection	-32Vdc

Input (3 terminal configuration)

Control voltage range	0 - 18 Vdc
Control current (max.)	240 μ A _{dc} @ 5V, 1mA @ 18V
Input supply voltage range (Vcc)	3.8 - 32 Vdc (Notes 1 & 2, Figures 1 & 2)
Input current (max.) @ 5Vdc	15mA _{dc} (Notes 1 & 2, Figures 1 & 2)
Must turn-on voltage	0.3Vdc
Must turn-off voltage	3.2Vdc

I/O

Dielectric Strength (min.)	1,000V rms
Insulation Resistance (min.) @ 500Vdc	10 ⁹ ohms
Capacitance (max.)	10pF

Output

Continuous load current (max.) @ 25°C, without short circuit protection	2.0A _{dc} (Figure 5, Note 3)
Continuous load current (max.) @ 25°C, with short circuit protection	1.0A _{dc} (Figure 5, Note 3)
Continuous load voltage (max.)	60Vdc
Transient blocking voltage (max.)	80Vdc (Note 4)
On resistance (max.) @ T _j = 25°C, I _L = 100ma, with short circuit protection	0.45 ohm (Note 5, Figure 4)
On resistance (max.) @ T _j = 25°C, I _L = 100ma, without short circuit protection	0.22 ohm (Note 5, Figure 4)
Output voltage drop (max.), with short circuit protection	0.6Vdc
Output voltage drop (max.), without short circuit protection	0.75Vdc
Off-state leakage current (max.) @ 60Vdc	100 μ A _{dc}
Turn-on time (max.)	1.5 ms (Figure 3)
Turn-off time (max.)	.25 ms (Figure 3)
dv/dt (min.)	100V / μ s
Electrical system spike	\pm 600Vdc (Note 4)
Junction temperature (max.)	150°C
Thermal resistance (max.), junction to ambient	80°C/W
Thermal resistance (max.), junction to case	20°C/W

Status

Status supply voltage	30Vdc
Status sink current (max.) @ V _{status} = 0.3Vdc	2mA _{dc} (Note 7)
Status leakage current (max.) @ 15Vdc	4 μ A _{dc}

Short Circuit Protection

See Figure 6, Note 7

DS13 SSR for loads up to 2A @ 60Vdc (Continued)

Figure 1 - Maximum Input Current vs. Input Voltage

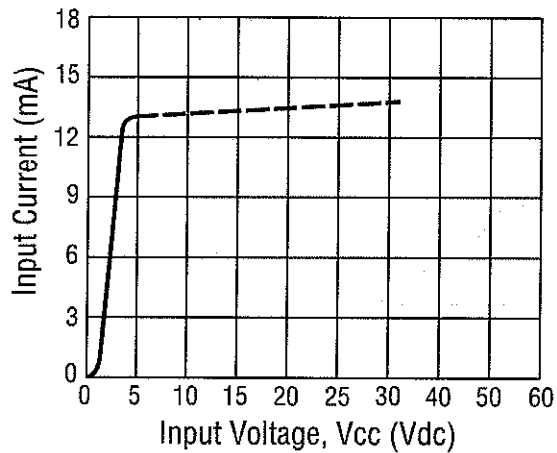

Figure 2 - Series Resistance vs. Vcc Supply Voltage (Note 1)

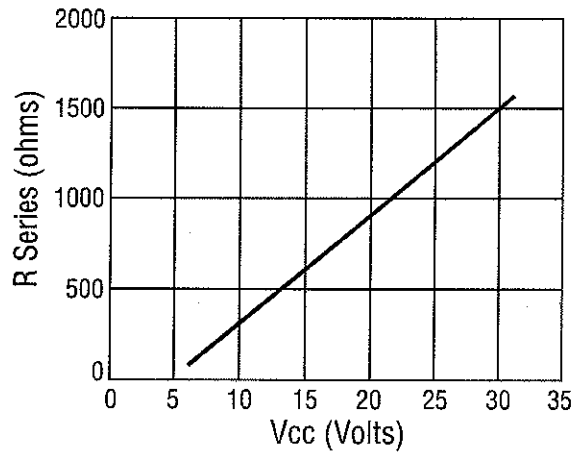

Figure 3 - Output Turn-on and Turn-off Timing

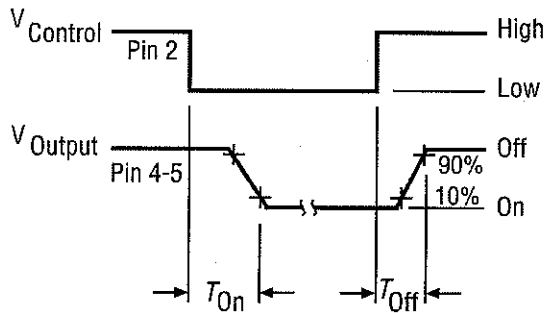

Figure 4 - On-Resistance vs. Temperature (Note 6)

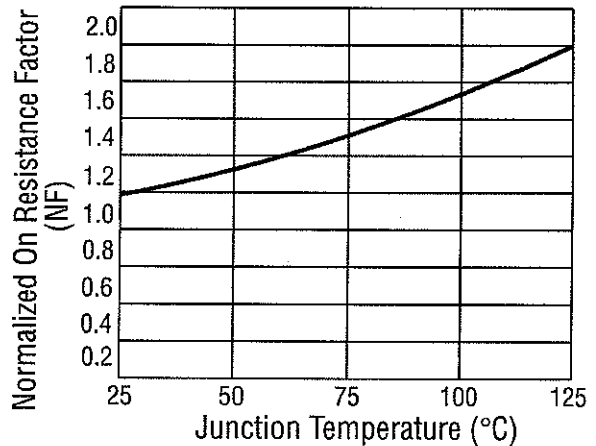

Figure 5 - Temperature Derating Curve

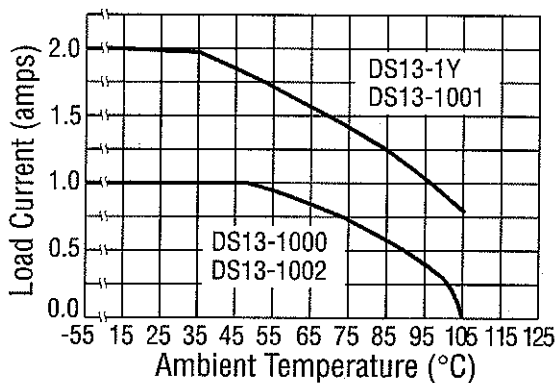
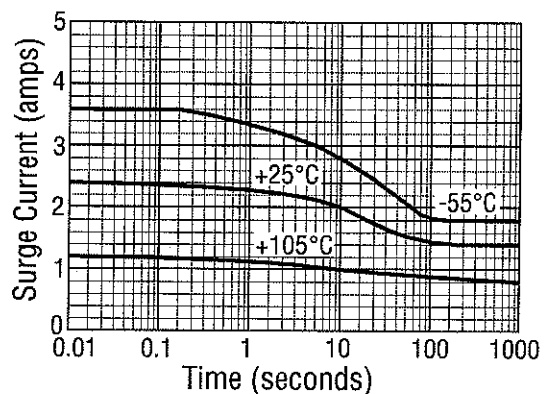
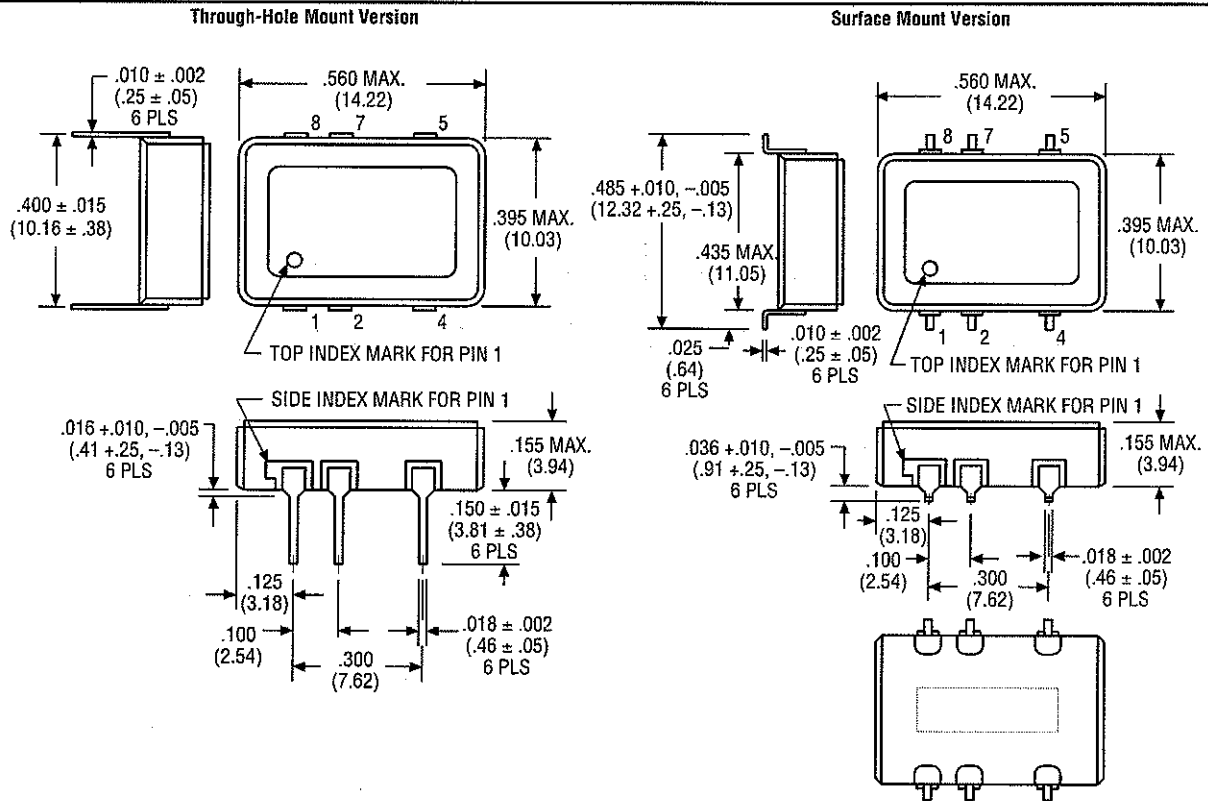

Figure 6 - Typical Current Trip Levels



DS13 SSR for loads up to 2A @ 60Vdc (Continued)

Figure 7 - Outline Dimensions



Notes

1. 2 terminal input configuration is compatible with CMOS or open collector TTL (with pull-up resistor). For Vcc levels above 6Vdc, a series limiting resistor is required. See Fig. 2 for resistor value. Use standard resistor value equal to or less than value from the curve.
2. Vcc = 5Vdc for all tests unless otherwise specified.
3. All DS13 Series relays may drive loads connected to either positive or negative referenced power supply lines. Reversing polarity of output may cause permanent damage. Inductive loads must be diode suppressed.
4. Transient blocking voltage & electrical system spike tests are performed per MIL-STD-704 (28Vdc systems).
5. To determine the maximum on-resistance at any given junction temperature, multiply on-resistance at 25°C by normalized on-resistance factor from curve (Fig. 4).
6. Overload testing per MIL-R-28750 is constrained to the limits imposed by the short circuit protection requirements of this specification and DSCC drawing 90091. Load circuit series inductance for "load shorted" mode of operation to be limited to 50mH max. Maximum repetition rate into a shorted load should not exceed 10 Hz. To calculate maximum on-resistance at any temperature, use the following equation: $R(on) = R(on) @ 25^{\circ}C \times NF$ (without short circuit protection) and $R(on) = 0.2 \times NF + .21$ (with short circuit protection) where NF = normalized on-resistance factor from Fig. 4.
7. Proper operation of the status feedback requires a status pull-up resistor. Select the status resistor such that it limits status output current to 2mA: $R_{status} = V_{status} / 2mA$.