

RSW Series

Precision Current Resistor/ Busbar Shunts
5 Amp - 200 Amp



- 5 Amp - 200 Amp
- 50mV output
- 0.25 to 10 mΩ
- 0.25% tolerance
- Center mounted voltage taps
- Compact size
- Non-Inductive metal element



SPECIFICATIONS*							
Type	Rated Current (A)	Operating Current (A)	Resistance (mΩ)	Type	Rated Current (A)	Operating Current (A)	Resistance (mΩ)
RSW-5-50	5	3.33	10	RSW-60-50	60	40	0.83
RSW-10-50	10	6.67	5	RSW-75-50	75	50	0.67
RSW-15-50	15	10	3.33	RSW-80-50	80	53.33	0.625
RSW-20-50	20	13.33	2.5	RSW-100-50	100	66.67	0.5
RSW-25-50	25	16.67	2	RSW-120-50	120	80	0.417
RSW-30-50	30	20	1.67	RSW-125-50	125	83.33	0.4
RSW-40-50	40	26.67	1.25	RSW-150-50	150	100	0.333
RSW-50-50	50	33.33	1	RSW-200-50	200	133.33	0.25

*Please consult factory for additional options

SPECIFICATIONS	
Rated Output	50mV Standard, Custom Available
Voltage Tolerance	±0.25% Standard
Operating Temp.	+30°C to +70°C
Storage Temp.	-55°C to 80°C
Materials	Flame resistant all metal design Resistance Element: Manganin Terminal Block RSW: Brass

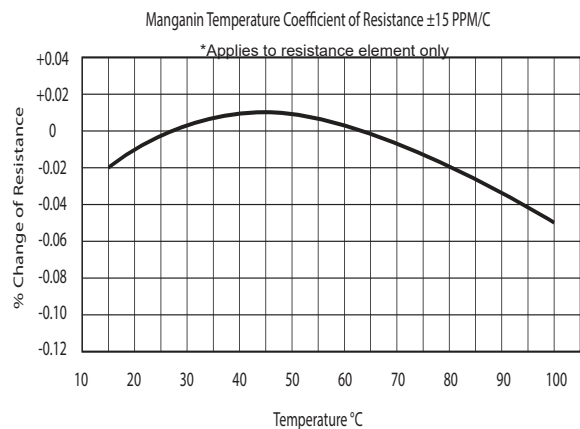

Operating Current Derating: For continuous operation, it is recommended that shunts are not run at more than two thirds (2/3) the rated current under normal conditions per IEEE standards for DC instrument shunts. At ambient temperatures above 40°C, the current must be further derated to prevent damage.

RSW Series

Precision Current Resistor/ Busbar Shunts

5 Amp - 200 Amp

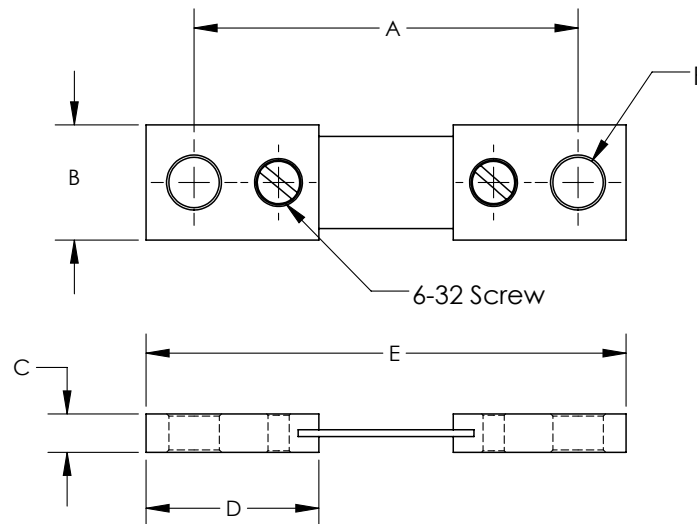

Dimensions - inches (mm)

Type	A ± 0.015 (0.38)	B ± 0.031 (0.79)	C ± 0.031 (0.79)	D ± 0.031 (0.79)	E ± 0.031 (0.79)	F through (standard) ± 0.005 (0.13)	F threaded* (optional)
RSW-5-50	2.5 (63.5)	0.5 (12.7)	0.25 (6.35)	1.125 (28.58)	3.13 (79.5)	0.266 (6.73)	1/4 - 20
RSW-10-50	2.5 (63.5)	0.5 (12.7)	0.25 (6.35)	1.125 (28.58)	3.13 (79.5)	0.266 (6.73)	1/4 - 20
RSW-15-50	2.5 (63.5)	0.5 (12.7)	0.25 (6.35)	1.125 (28.58)	3.13 (79.5)	0.266 (6.73)	1/4 - 20
RSW-20-50	2.5 (63.5)	0.5 (12.7)	0.25 (6.35)	1.125 (28.58)	3.13 (79.5)	0.266 (6.73)	1/4 - 20
RSW-25-50	2.5 (63.5)	0.5 (12.7)	0.25 (6.35)	1.125 (28.58)	3.13 (79.5)	0.266 (6.73)	1/4 - 20
RSW-30-50	2.5 (63.5)	0.5 (12.7)	0.25 (6.35)	1.125 (28.58)	3.13 (79.5)	0.266 (6.73)	1/4 - 20
RSW-40-50	2.5 (63.5)	0.5 (12.7)	0.25 (6.35)	1.125 (28.58)	3.13 (79.5)	0.266 (6.73)	1/4 - 20
RSW-50-50	2.5 (63.5)	0.5 (12.7)	0.25 (6.35)	1.125 (28.58)	3.13 (79.5)	0.266 (6.73)	1/4 - 20
RSW-60-50	2.5 (63.5)	0.75 (19.1)	0.25 (6.35)	1.125 (28.58)	3.13 (79.5)	0.266 (6.73)	1/4 - 20
RSW-75-50	2.5 (63.5)	0.75 (19.1)	0.25 (6.35)	1.125 (28.58)	3.13 (79.5)	0.328 (8.33)	5/16 - 18
RSW-80-50	2.5 (63.5)	0.75 (19.1)	0.25 (6.35)	1.125 (28.58)	3.13 (79.5)	0.328 (8.33)	5/16 - 18
RSW-100-50	2.75 (69.85)	1.0 (25.4)	0.375 (9.53)	1.375 (34.93)	3.62 (91.95)	0.328 (8.33)	5/16 - 18
RSW-120-50	2.75 (69.85)	1.0 (25.4)	0.375 (9.53)	1.375 (34.93)	3.62 (91.95)	0.328 (8.33)	5/16 - 18
RSW-125-50	2.75 (69.85)	1.0 (25.4)	0.375 (9.53)	1.375 (34.93)	3.62 (91.95)	0.328 (8.33)	5/16 - 18
RSW-150-50	2.75 (69.85)	1.0 (25.4)	0.375 (9.53)	1.375 (34.93)	3.62 (91.95)	0.375 (9.53)	3/8 - 16
RSW-200-50	2.875 (73.03)	1.0 (25.4)	0.5 (12.7)	1.375 (34.93)	3.75 (95.25)	0.453 (11.51)	7/16 - 14

Ordering Information

Part Description: Part Type - Rated Current - Voltage Output (mV) - TH (*optional threaded termination)

Example: **RSW-5-50**

RSW Series

Precision Current Resistor/ Busbar Shunts

5 Amp - 200 Amp



TECHNICAL NOTES

Mounting: Shunts should be mounted with manganin resistive blades in a vertical position in order to promote the free convectional flow of air. If vertical mounting is not practical, forced air cooling or adding heat sinks to the blocks can reduce the operating temperature. The manganin blades must never exceed +145°C, otherwise permanent resistance change may occur.

When current of 100A or greater is passing through the shunt, the major portion of heat generated is dissipated by conduction through the shunt terminal blocks into the connecting buss bar or cable. Therefore it is necessary to insure that good contact is made between the shunt terminal blocks and the conductor terminals and that the conductors have adequate cross section to keep the temperature of the shunt from exceeding 145°C (125°C recommended).

If the shunt is mounted in an enclosure, care must be taken to ensure adequate cooling. If the power density is greater than 1/4 watt per square inch of the enclosure surface for all enclosed devices, additional cooling must be supplied in the form of air vents or fans.

Shunts also must be installed in a way that protects them from thermal expansion forces produced from buss bar or short-circuit forces. Flexible wiring may be required in high pulse current, high vibration, or high temperature applications.

Where possible, all shunts should be mounted on the ground side of the circuit. For circuits above 750VDC, RS shunts **must** be mounted on the ground side due to the dielectric strength of the shunt base.

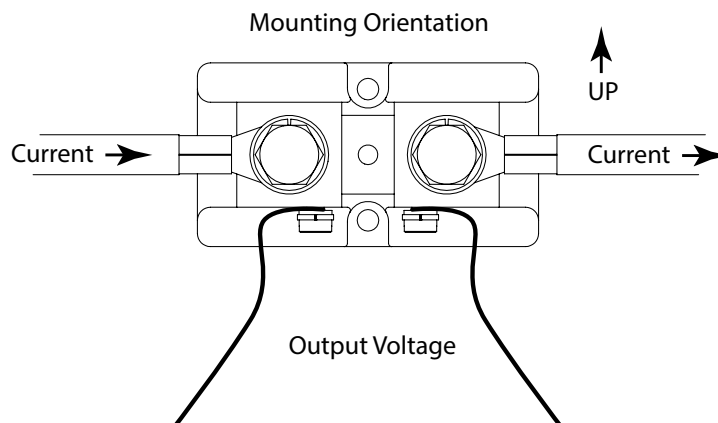

Operating Current Derating: For continuous operation, it is recommended that shunts are not run at more than two thirds (2/3) the rated current under normal conditions per IEEE standards for DC instrument shunts. At ambient temperatures above 40°C, the current must be further derated to prevent damage.

Pulse Operation: Shunts that do not need continuous operation and are only exposed to intermittent pulses can be operated at levels above their rated current for short periods of times. Pulses are limited to the maximum temperature of the blades not exceeding 145°C (125°C recommended). Many variables such as ambient temperature, cross section of the current carrying conductors, and pulse duration make calculating exact values difficult. Shunt size will need to be validated by customer for pulse current and duty cycle on a case by case basis.