

Data Sheet



SERCOS

SERCOS is a Serial Realtime Communication System, a standard digital interface for communication between controls and drives for numerically controlled machines. The SERCOS interface specification was written by a joint working group of the VDW (German Machine Tool Builders Association) and ZVEI (German Electrical and Electronic Manufacturer's Association) to allow data exchange between NC controls and drives via fiber optic rings, with isolation and noise immunity. The HFBR-0600Z family of fiber optic transmitters and receivers comply to the SERCOS specifications for transmitter and receiver optical characteristics and connector style (SMA).

Description

The HFBR-0600Z components are capable of operation at symbol rates from DC to over 2 MBd and distances from 0 to over 20 meters. The HFBR-1602Z and HFBR-1604Z transmitters contain a 655 nm AlGaAs emitter capable of efficiently launching optical power into 1 mm plastic optical fiber. The optical output is specified at the end of 0.5 m of plastic optical fiber.

The HFBR-1604Z is a selected version of the HFBR-1602Z, with power specified to meet the SERCOS high attenuation specifications.

The HFBR-2602Z receiver incorporates an integrated photo IC containing a photodetector and DC amplifier driving an open-collector Schottky output transistor. The HFBR-2602Z is designed for direct interfacing to popular logic families. The absence of an internal pull-up resistor allows the open-collector output to be used with logic families, such as CMOS, requiring voltage excursions higher than V_{CC} . The HFBR-2602Z has a dynamic range of 15 dB.

Features

- RoHS compliant
- Fully compliant to SERCOS optical specifications
- Optimized for 1 mm plastic optical fiber
- Compatible with SMA connectors
- Auto-insertable and wave solderable
- Data transmission at symbol rates from DC to over 2 MBd for distances from 0 to over 20 meters

Applications

- Industrial control data links
- Reduction of lightning and voltage transient susceptibility
- Tempest-secure data processing equipment
- Isolation in test and measurement instruments
- Robotics communication

CAUTION The small junction sizes inherent to the design of this component increase the component's susceptibility to damage from electrostatic discharge (ESD). It is advised that normal static precautions be taken in handling and assembly of this component to prevent damage and/or degradation that may be induced by ESD.

Figure 1 HFBR-160XZ Transmitters

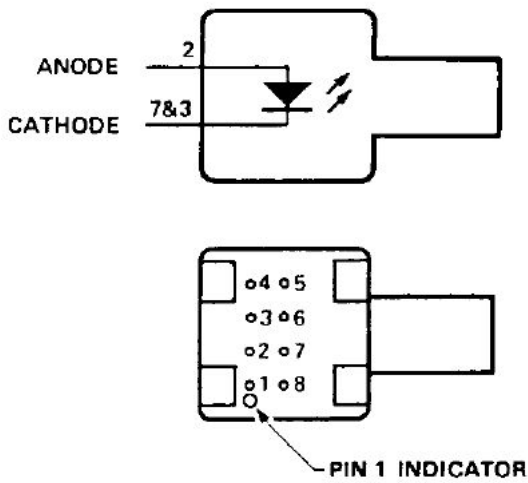

Pin	Function
1 ^a	N.C.
2	ANODE
3 ^b	CATHODE
4 ^a	N.C.
5 ^a	N.C.
6	N.C.
7 ^b	CATHODE
8 ^a	N.C.

- a. Pins 1, 4, 5, and 8 are isolated from the internal circuitry, but electrically connected to one another.
- b. Pins 3 and 7 are electrically connected to the header.

Figure 2 HFBR-2602Z Receiver

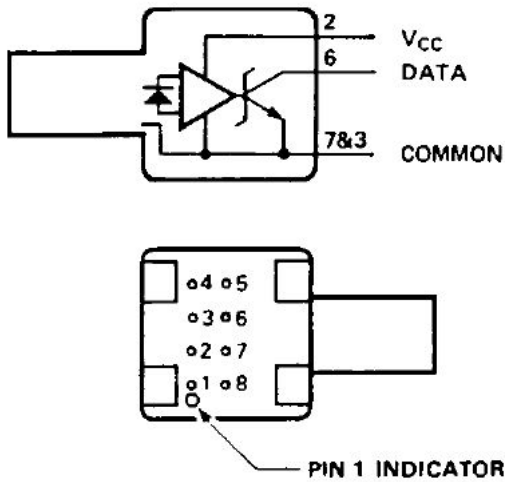

Pin	Function
1 ^a	N.C.
2	V _{CC} (5V)
3	COMMON
4 ^a	N.C.
5 ^a	N.C.
6	DATA
7	COMMON
8 ^a	N.C.

- a. Pins 1, 4, 5, and 8 are isolated from the internal circuitry, but electrically connected to one another.

In the receiver, both the open-collector "Data" output Pin 6 and V_{CC} Pin 2 are referenced to "Common" Pin 3 and 7. It is essential that a bypass capacitor (0.1 μF ceramic) be connected from Pin 2 (V_{CC}) to Pin 3 (circuit common) of the receiver.

HFBR-0600Z SMA Series

Figure 3 Mechanical Dimensions

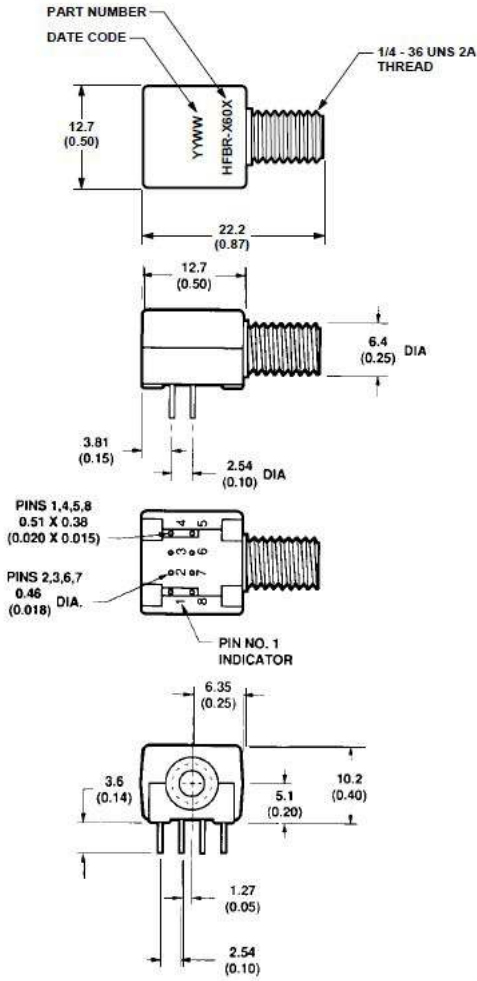

NOTE All dimensions in mm (inches).

SMA is an industry standard fiber optic connector, available from many fiber optic connector suppliers. HFBR-4401Z is a kit consisting of 100 nuts and 100 washers for panel mounting the HFBR-0600Z components.

HFBR-1602Z/1604Z Transmitters

Table 1 Absolute Maximum Ratings

Parameter	Symbol	Min.	Max.	Units	Reference
Storage Temperature	T_S	-55	85	°C	
Operating Temperature	T_A	-40	85	°C	
Lead Soldering Cycle	Temp.		260	°C	a
	Time		10	s	a
Forward Input Current Peak	I_{FPK}		120	mA	
Forward Input Current Average	I_{Favg}		60	mA	
Reverse Input Voltage	V_{BR}		-5	V	

a. 2.0 mm from where leads enter case.

Table 2 Electrical/Optical Characteristics 0 to 55°C, unless otherwise stated

Parameter	Symbol	Min.	Typ. ^a	Max.	Unit	Condition	Reference
Forward Voltage	V_F	1.5	1.9	2.2	V	$I_F = 35$ mA	
Forward Voltage Temp. Coefficient	$\Delta V_F/\Delta T$		-1.2		mV/°C	$I_F = 35$ mA	
Reverse Input Voltage	V_{BR}	-5.0	-18		V	$I_R = 100$ μ A	
Peak Emission Wavelength	λ_P	640	655	675	nm		
Full Width Half Maximum	FWHM		20	30	nm	25°C	
Diode Capacitance	C_T		30		pF	$V_F = 0, f = 1$ MHz	
Optical Power Temp. Coefficient	$\Delta P_T/\Delta T$		-0.01		dBm/°C	$I_F = 35$ mA	
Thermal Resistance	θ_{JA}		330		°C/W		b, c
Peak Optical Output Power of HFBR-1602Z	P_{T1602}	-10.5		-5.5	dBm	$I_F = 35$ mA	d, e, f
Peak Optical Output Power of HFBR-1604Z	P_{T1604}	-7.5		-3.5	dBm	$I_F = 60$ mA	d, e, f
		-10.5		-5.5	dBm	$I_F = 35$ mA	
Rise Time (10% to 90%)	t_r		57		ns	$I_F = 60$ mA	
			50		ns	$I_F = 35$ mA	
Fall Time (90% to 10%)	t_f		40		ns	$I_F = 60$ mA	
			27		ns	$I_F = 35$ mA	

- Typical data at $T_A = +25^\circ\text{C}$.
- Thermal resistance is measured with the transmitter coupled to a connector assembly and fiber, and mounted on a printed circuit board.
- Pins 2, 6, and 7 are welded to the cathode header connection to minimize the thermal resistance from junction to ambient. To further reduce the thermal resistance, the cathode trace should be made as large as is consistent with good RF circuit design.
- P_T is measured with a large area detector at the end of 0.5 meter of plastic optical fiber with 1 mm diameter and numerical aperture of 0.5.
- When changing μW to dBm, the optical power is referenced to 1 mW (1000 μW). Optical Power $P(\text{dBm}) = 10 \log [P(\mu\text{W})/1000 \mu\text{W}]$.
- Both HFBR-1602Z and HFBR-1604Z meet the SERCOS "low attenuation" specifications when operated at 35 mA; only HFBR-1604Z meets the SERCOS "high attenuation" limits when operated at 60 mA.

HFBR-2602Z Receiver

Table 3 Absolute Maximum Ratings

Parameter		Symbol	Min.	Max.	Units	Reference
Storage Temperature		T_S	-55	85	°C	
Operating Temperature		T_A	-40	85	°C	
Lead Soldering Cycle	Temp.			260	°C	a
	Time			10	s	a
Supply Voltage		V_{CC}	-0.5	7.0	V	
Output Current		I_O		25	mA	
Output Voltage		V_O	-0.5	18.0	V	
Output Collector Power Dissipation		$P_{O\text{ AVG}}$		40	mW	
Fan Out (TTL)		N		5		b

- a. 2.0 mm from where leads enter case.
 b. 8 mA load (5×1.6 mA), $R_L = 560 \Omega$.

Table 4 Electrical/Optical Characteristics 0 to 55 °C; Fiber Core Diameter ≤ 1.0 mm, Fiber N.A. ≤ 0.5 , $4.75V \leq V_{CC} \leq 5.25V$

Parameter	Symbol	Min.	Typ. ^a	Max.	Unit	Condition	Reference
High Level Output Current	I_{OH}		5	250	μA	$V_{OH} = 18V$, $P_R < -31.2$ dBm	
Low Level Output Voltage	V_{OL}		0.4	0.5	V	$I_{OL} = 8$ mA, $P_R > -20.0$ dBm	
High Level Supply Current	I_{CCH}		3.5	6.3	mA	$V_{CC} = 5.25V$, $P_R < -31.2$ dBm	
Low Level Supply Current	I_{CCL}		6.2	10	mA	$V_{CC} = 5.25V$, $P_R > -20.0$ dBm	

- a. Typical data at $T_A = +25^\circ\text{C}$.

Table 5 Dynamic Characteristics 0 to 55°C unless Otherwise Specified; $4.7V \leq V_{CC} \leq 5.25V$; BER $\leq 10^{-9}$

Parameter	Symbol	Min.	Typ. ^a	Max.	Unit	Condition	Reference
Peak Input Power Level Logic HIGH	P _{RH}			-31.2	dBm	$\lambda_p = 655 \text{ nm}$	b
Peak Input Power Level Logic LOW	P _{RL}	-20.0		-5.0	dBm	I _{OL} = 8 mA	b
Propagation Delay LOW to HIGH	t _{PLH}		60		ns	P _R = -20 dBm, 2 MBd	c, d
Propagation Delay HIGH to LOW	t _{PHL}		110		ns	P _R = -20 dBm, 2 MBd	c, d
Pulse Width Distortion, t _{PLH} - t _{PHL}	PWD		50 -50		ns ns	P _R = -5 dBm P _R = -20 dBm	e Figure 9

- Typical data at T_A = +25°C.
- Measured at the end of 1 mm plastic fiber optic cable with a large area detector.
- 8 mA load (5 × 1.6 mA), R_L = 560 Ω.
- Propagation delay through the system is the result of several sequentially occurring phenomena. Consequently it is a combination of data-rate-limiting effects and of transmission-time effects. Because of this, the data-rate limit of the system must be described in terms of time differentials between delays imposed on falling and rising edges. As the cable length is increased, the propagation delays increase. Data-rate, as limited by pulse width distortion, is not affected by increasing cable length if the optical power level at the receiver is maintained.
- Pulse width distortion is the difference between the delay of the rising and falling edges.

Figure 4 Forward Voltage and Current Characteristics

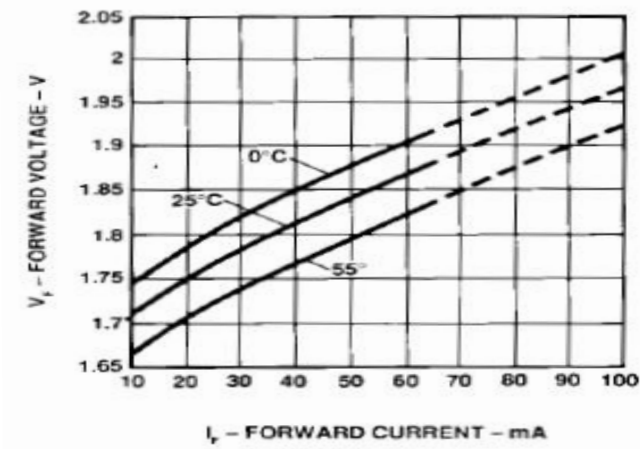

Figure 5 Typical Transmitter Output vs. Forward Current

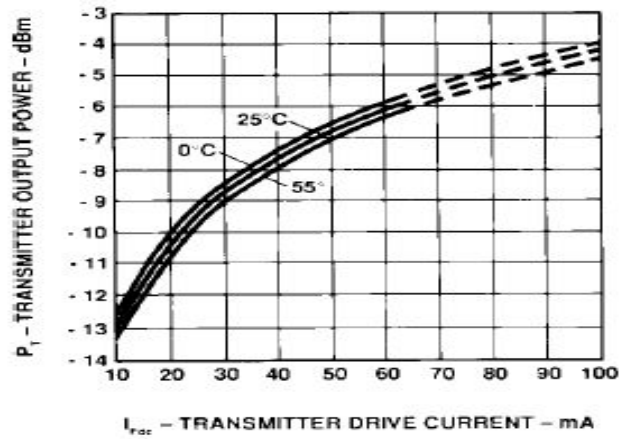

Figure 6 Transmitter Spectrum Normalized to the Peak at 25°C

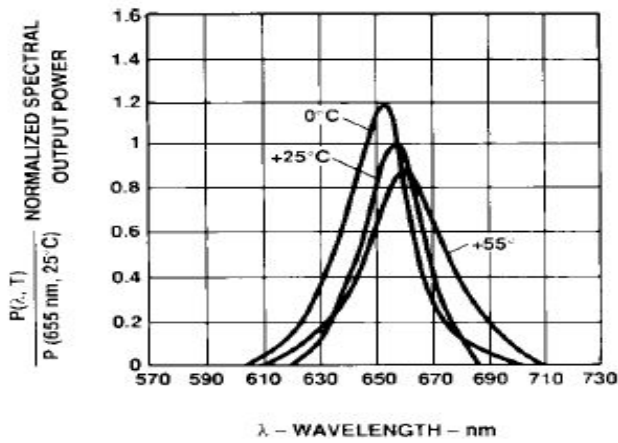

Figure 7 Typical Propagation Delay through System with 0.5m of Cable

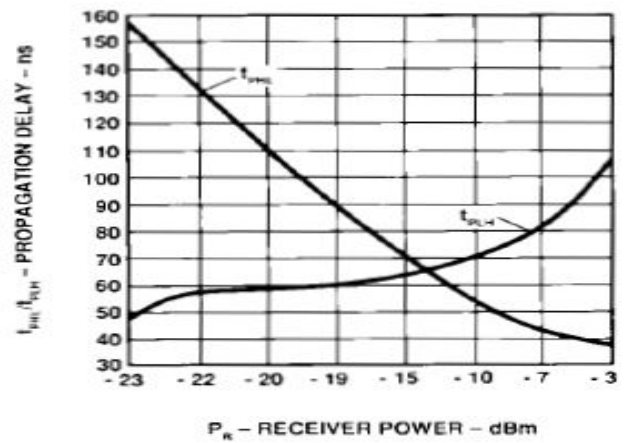

Figure 8 Typical HFBR-160XZ/2602Z Link Pulsewidth Distortion vs. Optical Power

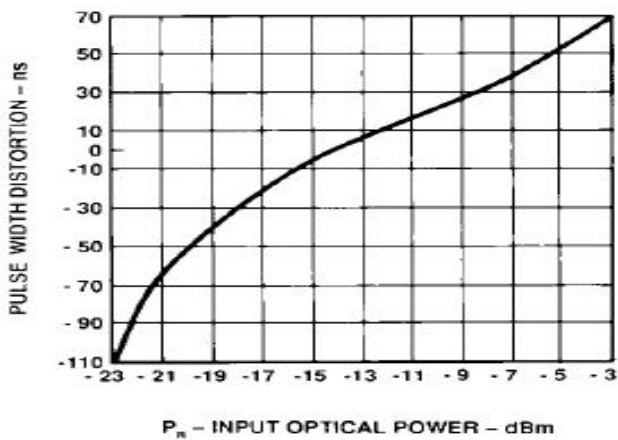
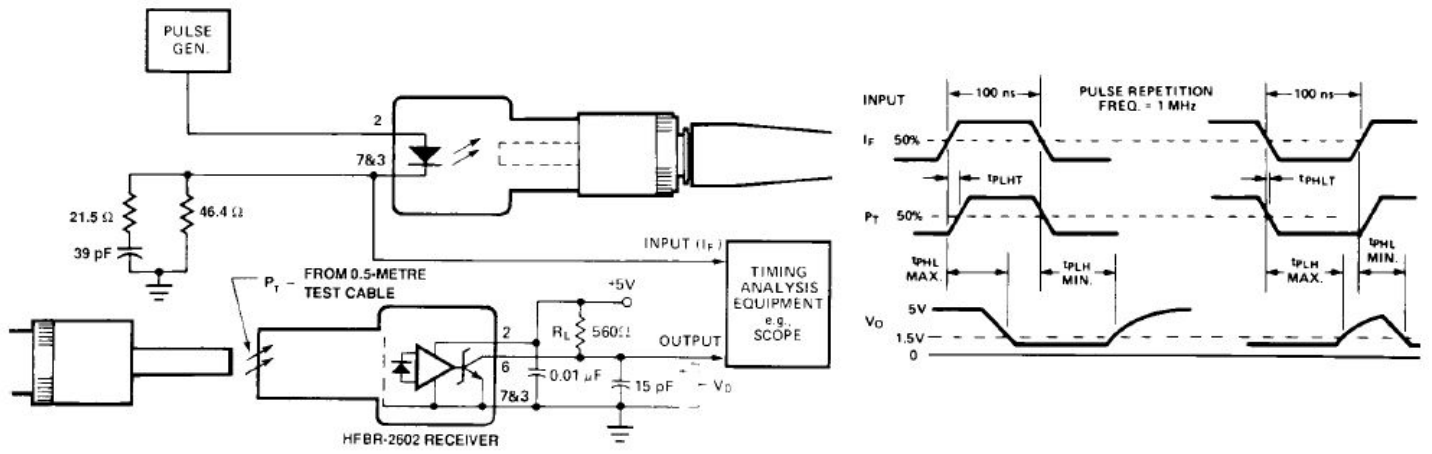

Figure 9 System Propagation Delay Test Circuit and Waveform Timing Definitions



For product information and a complete list of distributors, please go to our web site: www.broadcom.com.

Broadcom, the pulse logo, Connecting everything, Avago Technologies, Avago, and the A logo are among the trademarks of Broadcom and/or its affiliates in the United States, certain other countries and/or the EU.

Copyright © 2012–2016 by Broadcom. All Rights Reserved.

The term "Broadcom" refers to Broadcom Limited and/or its subsidiaries. For more information, please visit www.broadcom.com.

Broadcom reserves the right to make changes without further notice to any products or data herein to improve reliability, function, or design.

Information furnished by Broadcom is believed to be accurate and reliable. However, Broadcom does not assume any liability arising out of the application or use of this information, nor the application or use of any product or circuit described herein, neither does it convey any license under its patent rights nor the rights of others.

AV02-3638EN – December 2, 2016

