

TLE 7729

4 Channel Airbag Satellite Receiver IC SatRIC™



THE TLE 7729 – SatRIC™ - is a highly integrated interface IC specially designed for automotive restraint applications. The device, located in the ECU (Electronic Control Unit) of the airbag system, is able to receive data from different types of intelligent sensors like inertia and pressure sensor satellites for front-, side-, or rear-crash sensor applications. It provides a pre-regulated power supply voltage to the satellites over a twisted pair of wires. The satellite module transmits digital data to TLE 7729 by modulating the line current.

Applications

- Automotive Restraint Applications

Features

- 4 independent satellite receiver channels for current modulated data
- Each channel can support up to two satellites with a total of up to eight sensors
- Data rate 125 kBaud
- Support of 11-, 13-, 18-Bit Manchester 1 or 2 encoded messages
- Channel configuration in pairs (Bus Mode, Protocol Type)
- Supply of satellite channels via 4 independent voltage regulators
- Adjustable current level detection thresholds
- Asynchronous and synchronous data transmission modes
- All digital I/Os are 3.3 V and 5 V compatible
- 4 Digital outputs for voltage-converted received satellite signals
- 16-bit 8 MHz Serial Peripheral Interface (SPI)
- Embedded protocol handler for data preprocessing
- Small P-TSSOP-28 Package

Embedded Protection Functions

- Current limitation in case of satellite output shorted to GND or Battery
- Channel specific over-temperature shutdown

Embedded Diagnostic Functions

- Leakage detection to GND and Battery
- Ground loss detection
- Short to GND and open detection at every reference pins

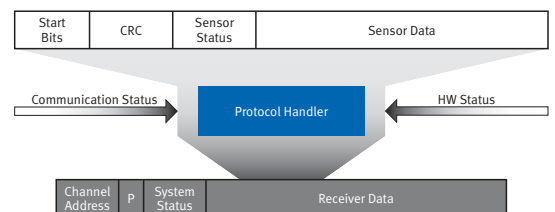
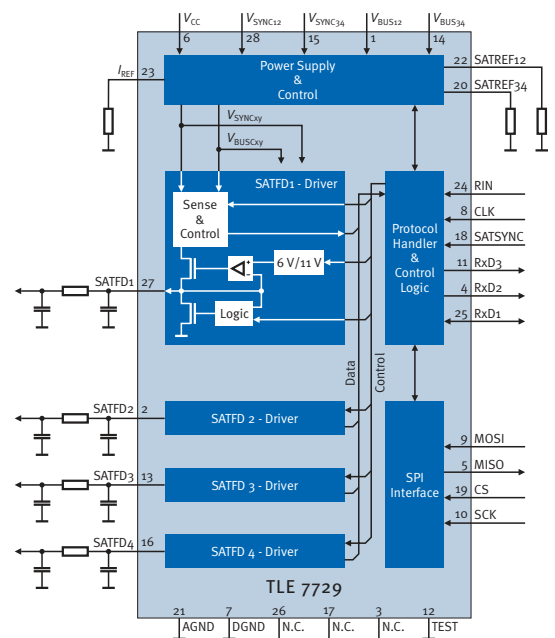

www.infineon.com/restraint-system-IC

Automotive Power



Never stop thinking

Product Brief

Application Examples (Side Impact)

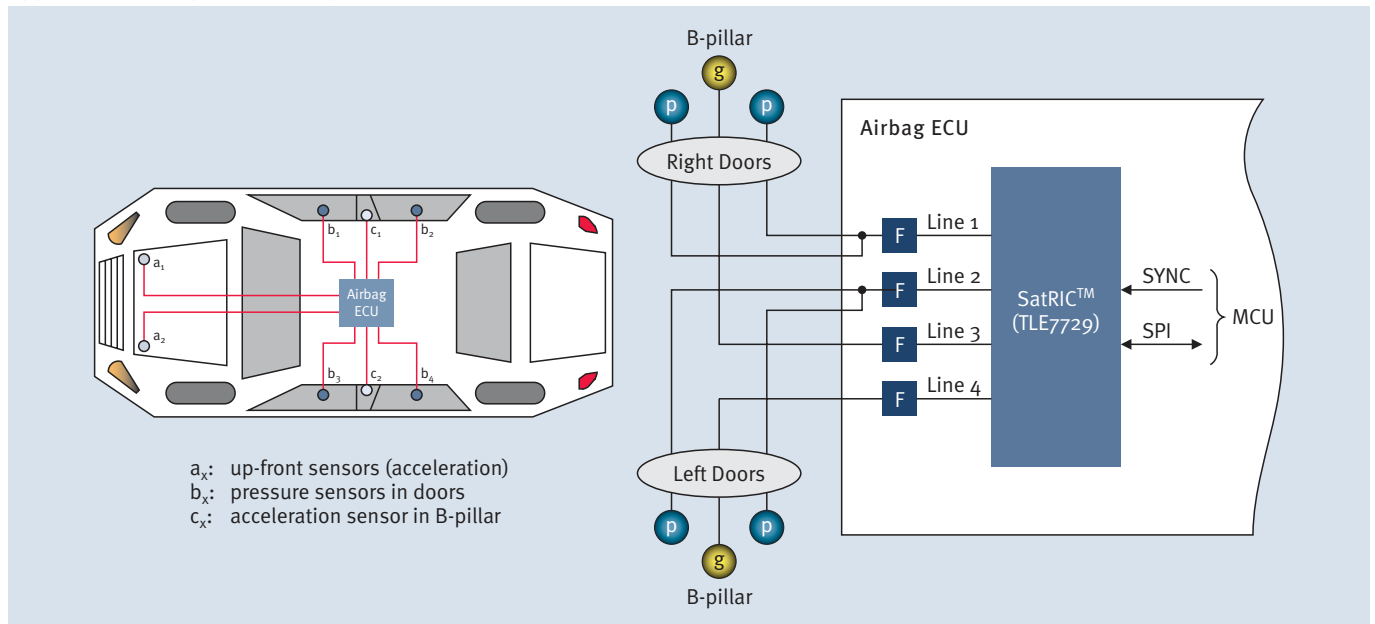

Product Summary

Type	Sales Code	Description	Package
TLE 7729	Available upon request	4 Channel Satellite Receiver	P-TSSOP-28

System Overview

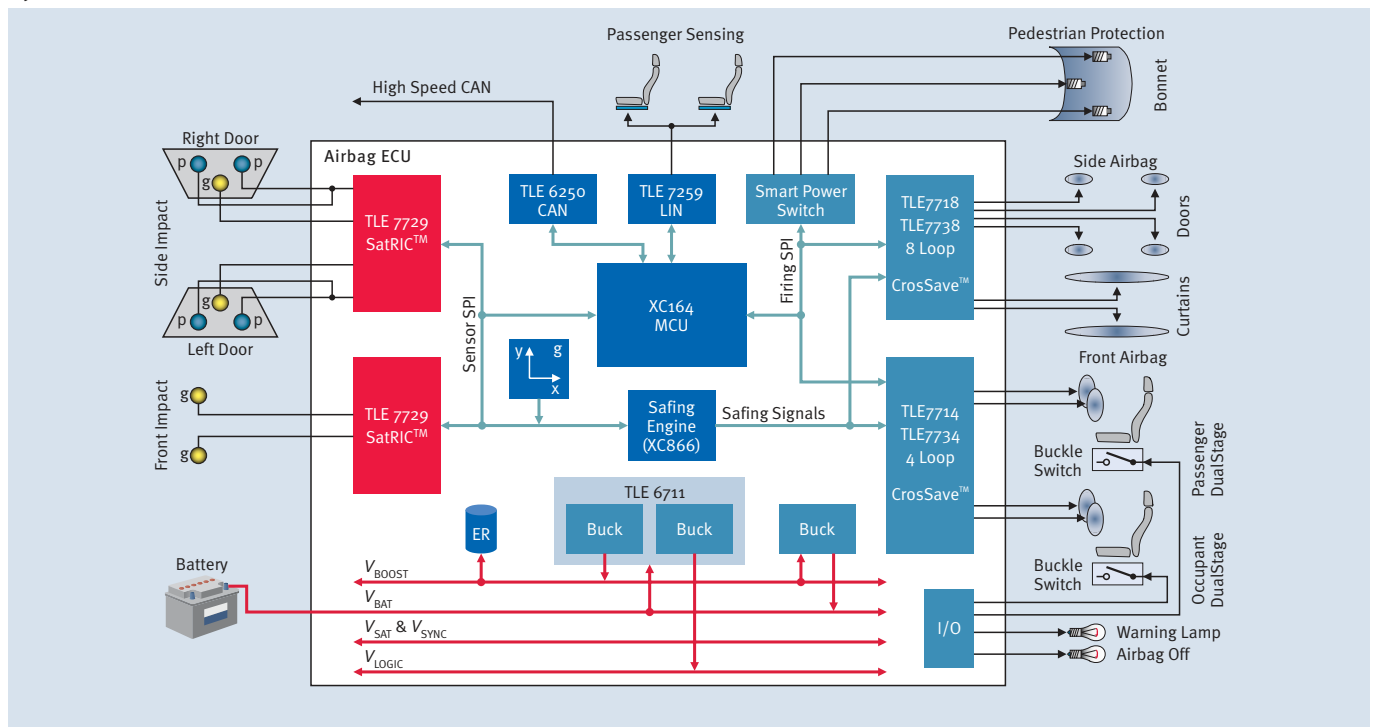

How to reach us:
<http://www.infineon.com>

Published by
Infineon Technologies AG
 81726 Munich, Germany

© Infineon Technologies AG 2006.
 All Rights Reserved.

Legal Disclaimer

The information given in this Product Brief shall in no event be regarded as a guarantee of conditions or characteristics ("Beschaffenheitsgarantie"). With respect to any examples or hints given herein, any typical values stated herein and/or any information regarding the application of the device, Infineon Technologies hereby disclaims any and all warranties and liabilities of any kind, including without limitation warranties of non-infringement of intellectual property rights of any third party.

Information

For further information on technology, delivery terms and conditions and prices please contact your nearest Infineon Technologies Office (www.infineon.com).

Warnings

Due to technical requirements components may contain dangerous substances. For information on the types in question please contact your nearest Infineon Technologies Office.

Infineon Technologies Components may only be used in life-support devices or systems with the express written approval of Infineon Technologies, if a failure of such components can reasonably be expected to cause the failure of that life-support device or system, or to affect the safety or effectiveness of that device or system.

Life support devices or systems are intended to be implanted in the human body, or to support and/or maintain and sustain and/or protect human life. If they fail, it is reasonable to assume that the health of the user or other persons may be endangered.

Ordering No. B112-H8941-X-X-7600
 Printed in Germany
 PS 1106.5 nb