

DATA SHEET

For a complete data sheet, please also download:

- The IC06 74HC/HCT/HCU/HCMOS Logic Family Specifications
- The IC06 74HC/HCT/HCU/HCMOS Logic Package Information
- The IC06 74HC/HCT/HCU/HCMOS Logic Package Outlines

74HC/HCT85 4-bit magnitude comparator

Product specification
File under Integrated Circuits, IC06

December 1990

4-bit magnitude comparator

74HC/HCT85

FEATURES

- Serial or parallel expansion without extra gating
- Magnitude comparison of any binary words
- Output capability: standard
- I_{CC} category: MSI

GENERAL DESCRIPTION

The 74HC/HCT85 are high-speed Si-gate CMOS devices and are pin compatible with low power Schottky TTL (LSTTL). They are specified in compliance with JEDEC standard no. 7A.

The 74HC/HCT85 are 4-bit magnitude comparators that can be expanded to almost any length. They perform comparison of two 4-bit binary, BCD or other monotonic codes and present the three possible magnitude results at the outputs ($Q_{A>B}$, $Q_{A=B}$ and $Q_{A<B}$). The 4-bit inputs are

weighted (A_0 to A_3 and B_0 to B_3), where A_3 and B_3 are the most significant bits.

The operation of the "85" is described in the function table, showing all possible logic conditions. The upper part of the table describes the normal operation under all conditions that will occur in a single device or in a series expansion scheme. In the upper part of the table the three outputs are mutually exclusive. In the lower part of the table, the outputs reflect the feed forward conditions that exist in the parallel expansion scheme.

For proper compare operation the expander inputs ($I_{A>B}$, $I_{A=B}$ and $I_{A<B}$) to the least significant position must be connected as follows: $I_{A<B} = I_{A>B} = \text{LOW}$ and $I_{A=B} = \text{HIGH}$.

For words greater than 4-bits, units can be cascaded by connecting outputs $Q_{A<B}$, $Q_{A>B}$ and $Q_{A=B}$ to the corresponding inputs of the significant comparator.

QUICK REFERENCE DATA

GND = 0 V; $T_{amb} = 25\text{ }^\circ\text{C}$; $t_r = t_f = 6\text{ ns}$

SYMBOL	PARAMETER	CONDITIONS	TYPICAL		UNIT
			HC	HCT	
t_{PHL}/t_{PLH}	propagation delay	$C_L = 15\text{ pF}$; $V_{CC} = 5\text{ V}$			
	A_n, B_n to $Q_{A>B}, Q_{A<B}$		20	22	ns
	A_n, B_n to $Q_{A=B}$		18	20	ns
	$I_{A<B}, I_{A=B}, I_{A>B}$ to $Q_{A<B}, Q_{A>B}$		15	15	ns
	$I_{A=B}$ to $Q_{A=B}$		11	15	ns
C_I	input capacitance		3.5	3.5	pF
C_{PD}	power dissipation capacitance per package	notes 1 and 2	18	20	pF

Notes

1. C_{PD} is used to determine the dynamic power dissipation (P_D in μW):

$$P_D = C_{PD} \times V_{CC}^2 \times f_i + \sum (C_L \times V_{CC}^2 \times f_o) \text{ where:}$$

f_i = input frequency in MHz

f_o = output frequency in MHz

$\sum (C_L \times V_{CC}^2 \times f_o)$ = sum of outputs

C_L = output load capacitance in pF

V_{CC} = supply voltage in V

2. For HC the condition is $V_I = \text{GND}$ to V_{CC}
For HCT the condition is $V_I = \text{GND}$ to $V_{CC} - 1.5\text{ V}$

ORDERING INFORMATION

See "74HC/HCT/HCU/HCMOS Logic Package Information".

4-bit magnitude comparator

74HC/HCT85

PIN DESCRIPTION

PIN NO.	SYMBOL	NAME AND FUNCTION
2	$I_{A<B}$	A < B expansion input
3	$I_{A=B}$	A = B expansion input
4	$I_{A>B}$	A > B expansion input
5	$Q_{A>B}$	A > B output
6	$Q_{A=B}$	A = B output
7	$Q_{A<B}$	A < B output
8	GND	ground (0 V)
9, 11, 14, 1,	B_0 to B_3	word B inputs
10, 12, 13, 15	A_0 to A_3	word A inputs
16	V_{CC}	positive supply voltage

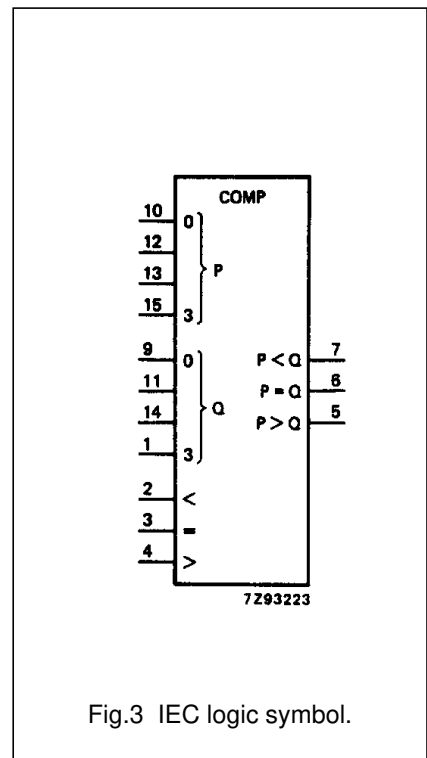
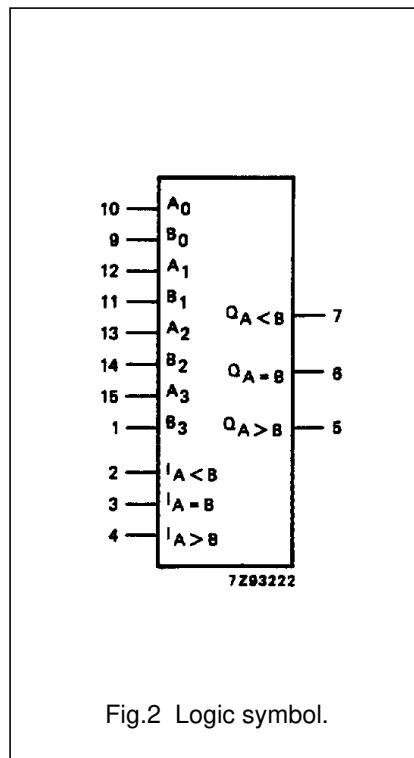
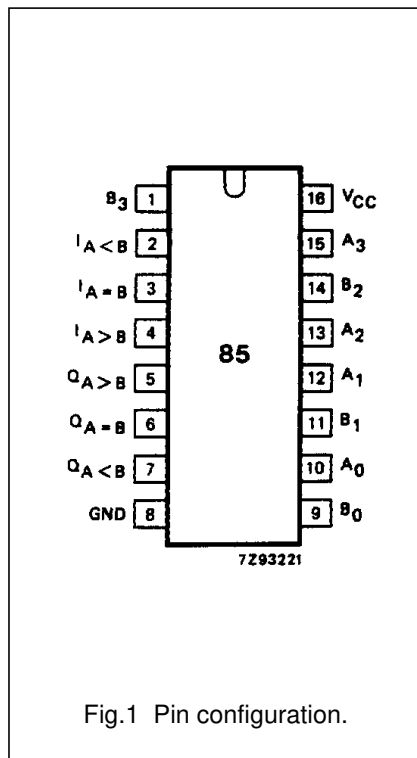

4-bit magnitude comparator

74HC/HCT85

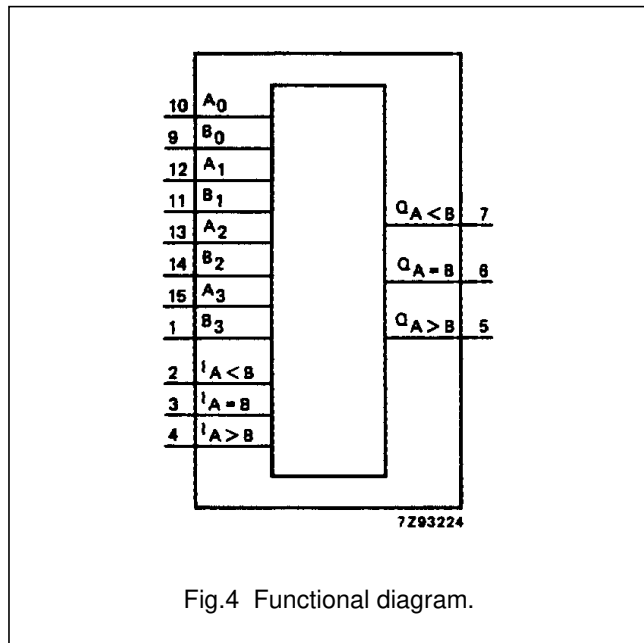

Fig.4 Functional diagram.

APPLICATIONS

- Process controllers
- Servo-motor control

FUNCTION TABLE

COMPARING INPUTS				CASCADING INPUTS			OUTPUTS		
A ₃ , B ₃	A ₂ , B ₂	A ₁ , B ₁	A ₀ , B ₀	I _{A>B}	I _{A<B}	I _{A=B}	Q _{A>B}	Q _{A<B}	Q _{A=B}
A ₃ >B ₃	X	X	X	X	X	X	H	L	L
A ₃ <B ₃	X	X	X	X	X	X	L	H	L
A ₃ =B ₃	A ₂ >B ₂	X	X	X	X	X	H	L	L
A ₃ =B ₃	A ₂ <B ₂	X	X	X	X	X	L	H	L
A ₃ =B ₃	A ₂ =B ₂	A ₁ >B ₁	X	X	X	X	H	L	L
A ₃ =B ₃	A ₂ =B ₂	A ₁ <B ₁	X	X	X	X	L	H	L
A ₃ =B ₃	A ₂ =B ₂	A ₁ =B ₁	A ₀ >B ₀	X	X	X	H	L	L
A ₃ =B ₃	A ₂ =B ₂	A ₁ =B ₁	A ₀ <B ₀	X	X	X	L	H	L
A ₃ =B ₃	A ₂ =B ₂	A ₁ =B ₁	A ₀ =B ₀	H	L	L	H	L	L
A ₃ =B ₃	A ₂ =B ₂	A ₁ =B ₁	A ₀ =B ₀	L	H	L	L	H	L
A ₃ =B ₃	A ₂ =B ₂	A ₁ =B ₁	A ₀ =B ₀	L	L	H	L	L	H
A ₃ =B ₃	A ₂ =B ₂	A ₁ =B ₁	A ₀ =B ₀	X	X	H	L	L	H
A ₃ =B ₃	A ₂ =B ₂	A ₁ =B ₁	A ₀ =B ₀	H	H	L	L	L	L
A ₃ =B ₃	A ₂ =B ₂	A ₁ =B ₁	A ₀ =B ₀	L	L	L	H	H	L

Notes

1. H = HIGH voltage level
L = LOW voltage level
X = don't care

4-bit magnitude comparator

74HC/HCT85

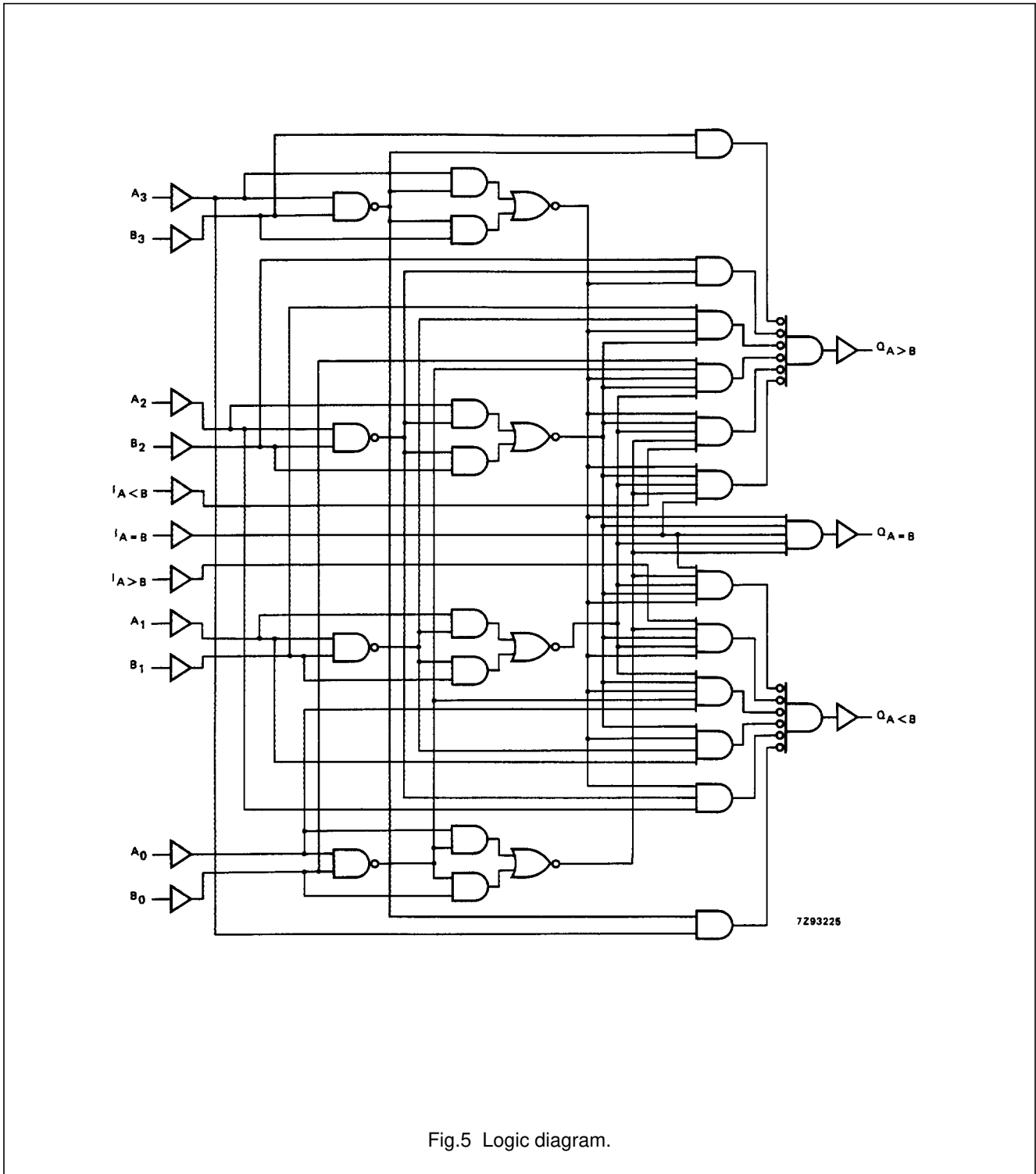

Fig.5 Logic diagram.

4-bit magnitude comparator

74HC/HCT85

DC CHARACTERISTICS FOR 74HC

For the DC characteristics see *"74HC/HCT/HCU/HCMOS Logic Family Specifications"*.

Output capability: standard

I_{CC} category: MSI

AC CHARACTERISTICS FOR 74HC

GND = 0 V; t_r = t_f = 6 ns; C_L = 50 pF

SYMBOL	PARAMETER	T _{amb} (°C)								UNIT	TEST CONDITIONS	
		74HC									V _{CC} (V)	WAVEFORMS
		+25			-40 to +85		-40 to +125					
		min.	typ.	max.	min.	max.	min.	max.				
t _{PHL} / t _{PLH}	propagation delay A _n , B _n to Q _{A>B} or Q _{A<B}		63 23 18	195 39 33		245 49 42		295 59 50	ns	2.0 4.5 6.0	Fig.6	
t _{PHL} / t _{PLH}	propagation delay A _n , B _n to Q _{A=B}		58 21 17	175 35 30		220 44 37		265 53 45	ns	2.0 4.5 6.0	Fig.6	
t _{PHL} / t _{PLH}	propagation delay I _{A<B} , I _{A=B} , I _{A>B} to Q _{A<B} , Q _{A>B}		50 18 14	140 28 24		175 35 30		210 42 36	ns	2.0 4.5 6.0	Fig.6	
t _{PHL} / t _{PLH}	propagation delay I _{A=B} to Q _{A=B}		39 14 11	120 24 20		150 30 26		180 36 31	ns	2.0 4.5 6.0	Fig.6	
t _{THL} / t _{TLH}	output transition time		19 7 6	75 15 13		95 19 16		110 22 19	ns	2.0 4.5 6.0	Fig.6	

4-bit magnitude comparator

74HC/HCT85

DC CHARACTERISTICS FOR 74HCT

For the DC characteristics see *"74HC/HCT/HCU/HCMOS Logic Family Specifications"*.

Output capability: standard

I_{CC} category: MSI

Note to HCT types

The value of additional quiescent supply current (ΔI_{CC}) for a unit load of 1 is given in the family specifications. To determine ΔI_{CC} per input, multiply this value by the unit load coefficient shown in the table below.

INPUT	UNIT LOAD COEFFICIENT
I _{A<B}	1.00
I _{A>B}	1.00
I _{A=B}	1.50
A _n , B _n	1.50

AC CHARACTERISTICS FOR 74HCT

GND = 0 V; t_r = t_f = 6 ns; C_L = 50 pF

SYMBOL	PARAMETER	T _{amb} (°C)						UNIT	TEST CONDITIONS		
		74HCT							V _{CC} (V)	WAVEFORMS	
		+25			-40 to +85		-40 to +125				
		min.	typ.	max.	min.	max.	min.				max.
t _{PHL} / t _{PLH}	propagation delay A _n , B _n to Q _{A>B} or Q _{A<B}		26	44		55		66	ns	4.5	Fig.6
t _{PHL} / t _{PLH}	propagation delay A _n , B _n to Q _{A=B}		24	40		50		60	ns	4.5	Fig.6
t _{PHL} / t _{PLH}	propagation delay I _{A<B} , I _{A=B} , I _{A>B} to Q _{A<B} , Q _{A>B}		18	31		39		47	ns	4.5	Fig.6
t _{PHL} / t _{PLH}	propagation delay I _{A=B} to Q _{A=B}		18	31		39		47	ns	4.5	Fig.6
t _{THL} / t _{TLH}	output transition time		7	15		19		22	ns	4.5	Fig.6

4-bit magnitude comparator

74HC/HCT85

AC WAVEFORMS

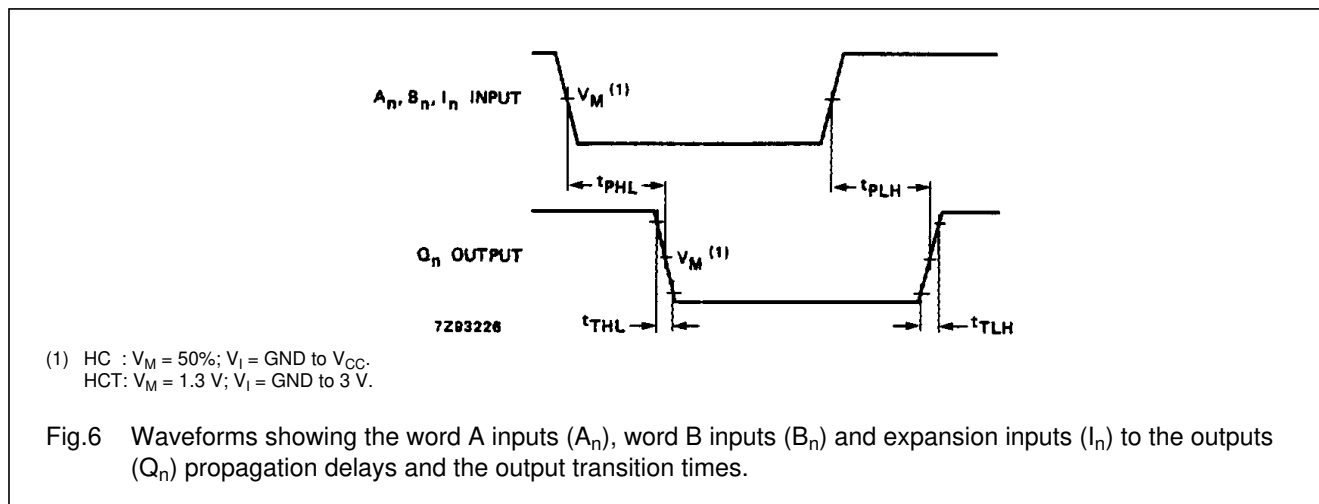

APPLICATION INFORMATION

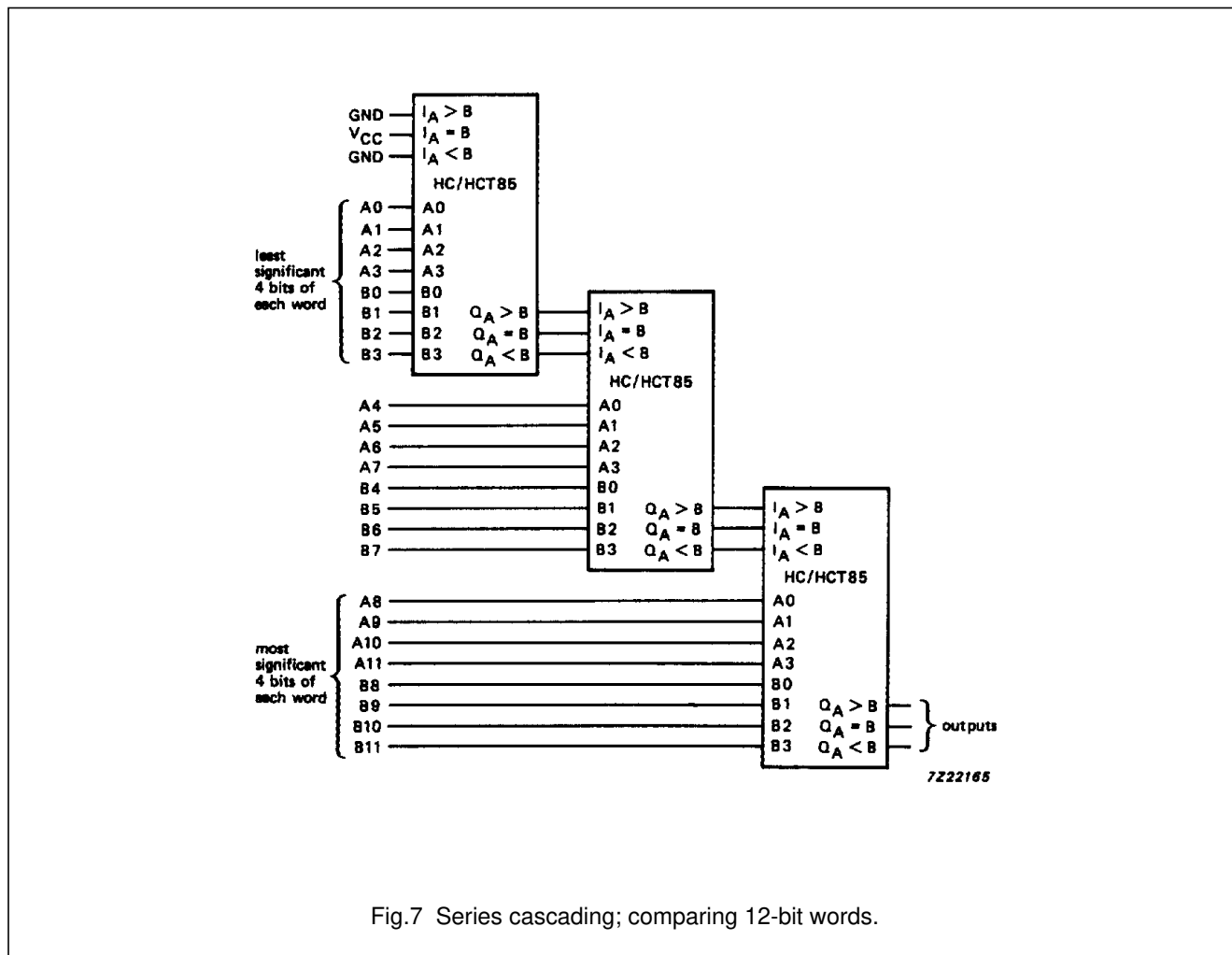

4-bit magnitude comparator

74HC/HCT85

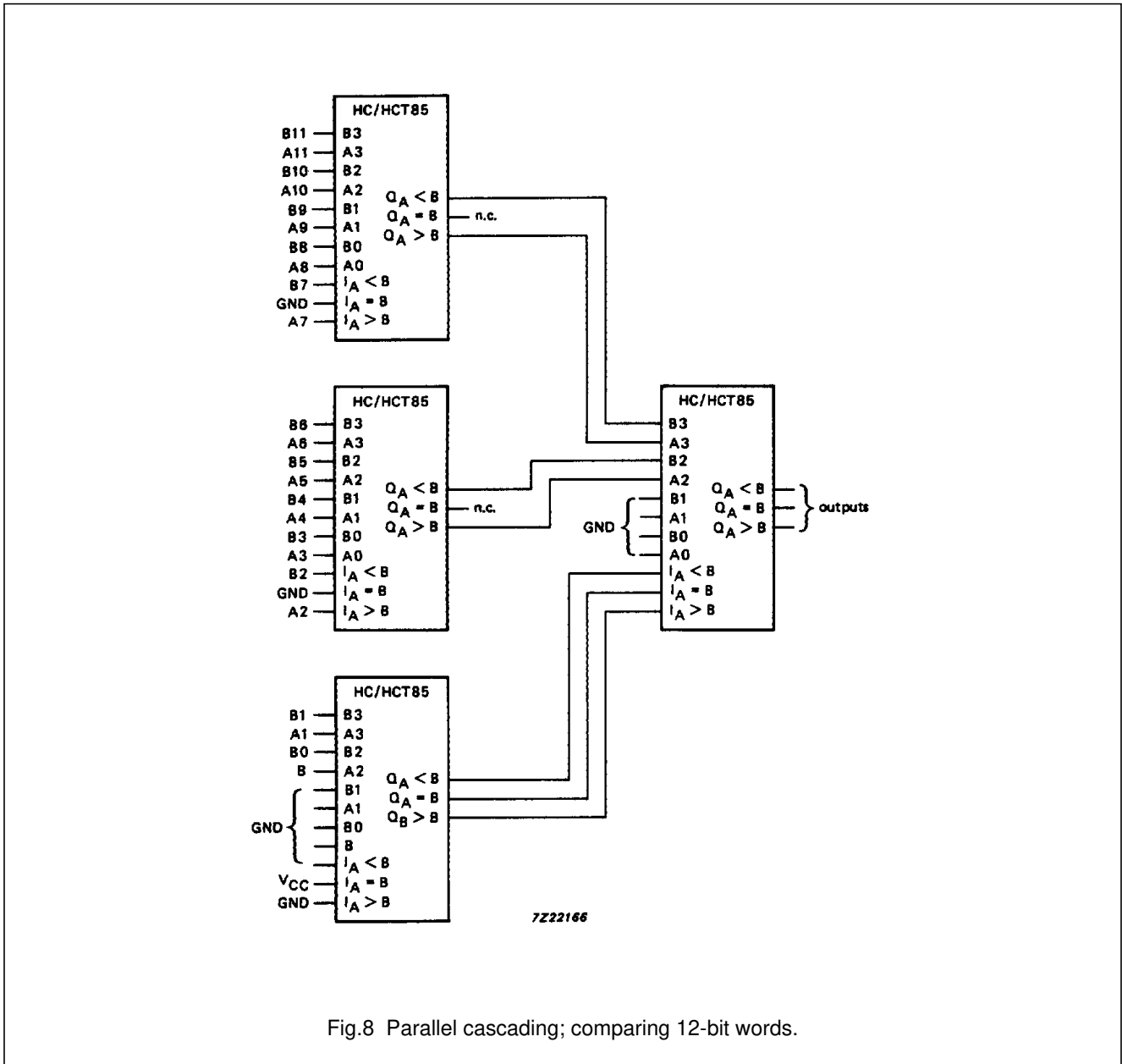

Fig.8 Parallel cascading; comparing 12-bit words.

PACKAGE OUTLINES

See "74HC/HCT/HCU/HCMOS Logic Package Outlines".