

THIS DRAWING IS UNPUBLISHED. RELEASED FOR PUBLICATION, 19 .
 © COPYRIGHT 19 BY AMP INCORPORATED. ALL INTERNATIONAL RIGHTS RESERVED.

LOC		DIST		P		F		ZONE		LTR		REVISIONS		DATE	APPD
CH	11														
												D	ECN 95033001	30/MAR/95	CMS

1. RETROFIT CONTACT FOR METRIMATE AND AMPLIMITE POWER CONTACT.
2. WIRE BARREL WILL ACCEPT #8 AWG WIRE.
3. MATES WITH PN 193457-1.

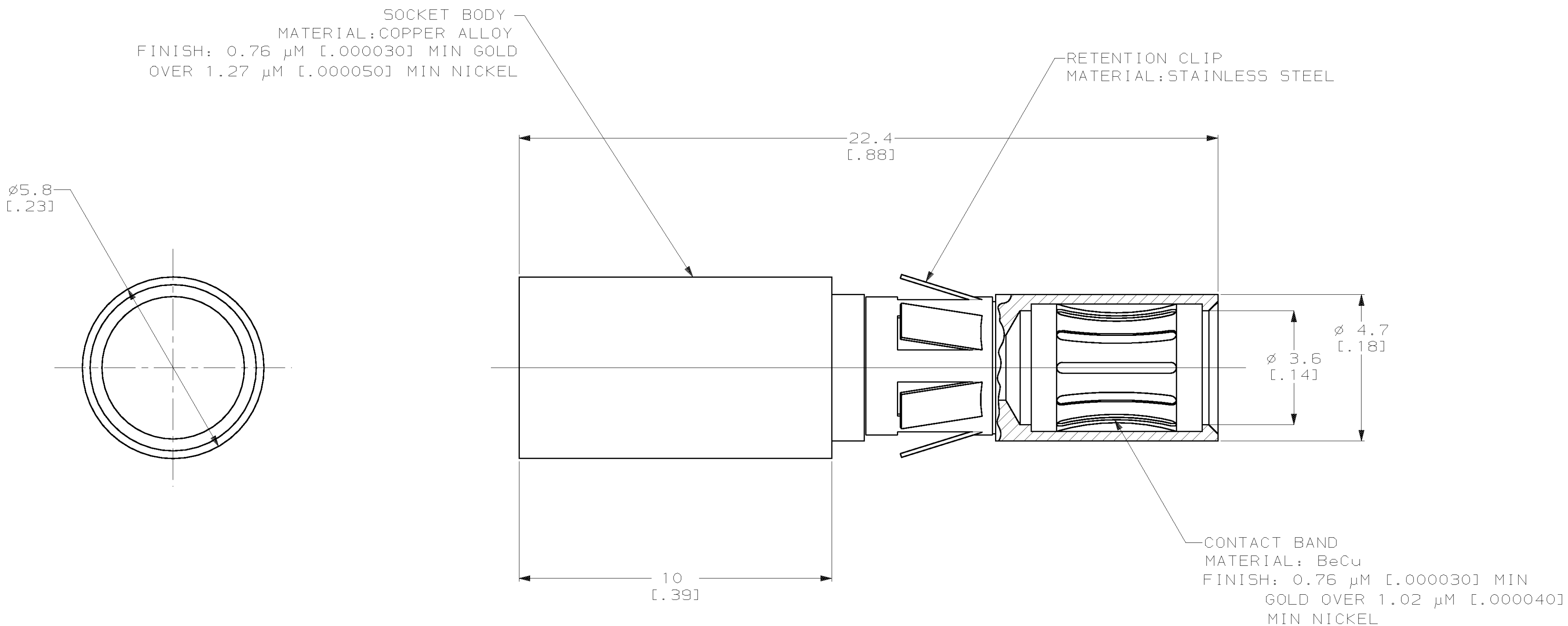

193458-1
PART NO

DO NOT SCALE PRINT. UNLESS SPECIFIED DIMENSIONS IN mm [INCHES] TOLERANCES ON : 2 PLC DEC ± 0.5 [.02] 3 PLC DEC ± 0.25 [.010] ANGLES ± -		DR D. WILSON 05-27-92		AMP Incorporated Harrisburg, PA 17105-3608	
MATERIAL -		CHK S. SIEGRIST 05-27-92			
FINISH -		APPD A. GRIFFIN 05-27-92		NAME	
-		APPD P. GLASER 05-27-92		SOCKET, POWER, #8 AWG	
-		PRODUCT SPEC -		SIZE	
-		APPLICATION SPEC -		CAGE CODE	
-		WEIGHT -		DRAWING NO	
-		-		C=193458	
-		-		SCALE 10:1	
-		-		SHEET 1 OF 1	

WAS 92-9991-003

THIS DRAWING IS A CONTROLLED DOCUMENT FOR AMP INCORPORATED. IT IS SUBJECT TO CHANGE AND THE CONTROLLING ENGINEERING ORGANIZATION SHOULD BE CONTACTED FOR THE LATEST REVISION.

CUSTOMER DRAWING