

1 2 3 4 5 6 7 8
 10120128 - X 0 C - X X X L F

6-COLUMN DIFFERENTIAL SIGNAL

LEAD-FREE DESIGNATION ONLY WITH APPLICABLE PLATING CODES

LETTER	PLATING (SEE NOTE 6)	
	APPLICATION	TYPE (REFERENCE)
B	TELCORDIA CO	0.76um GOLD or GXT
C	TELCORDIA UE	1.27um GOLD
D	TELCORDIA CO	0.76um GOLD or GXT, LEAD-FREE
E	TELCORDIA UE	1.27um GOLD, LEAD-FREE

NUMBER	GUIDE PIN STYLE (SEE NOTE 8)
0	STANDARD GUIDE PIN, MACHINED
1	STANDARD GUIDE PIN, ROLLED

NUMBER	CONTACT MATING WIPE LENGTH		COMPLIANT TAIL TYPE (SEE NOTE 9)
	SIGNAL	GROUND	
1	2 MM	4 MM	0.55 (0.0217") DRILL
2	3 MM	4 MM	0.55 (0.0217") DRILL
3	2 MM	4 MM	0.45 MICRO (0.0177") DRILL
4	3 MM	4 MM	0.45 MICRO (0.0177") DRILL
5	2 MM	3 MM	0.55 (0.0217") DRILL
6	3 MM	3 MM	0.55 (0.0217") DRILL
7	2 MM	3 MM	0.45 MICRO (0.0177") DRILL
8	3 MM	3 MM	0.45 MICRO (0.0177") DRILL

FOR CUSTOM-LOADED MODULES, SEE INDIVIDUAL CUSTOM DRAWINGS WITH THE DRAWING-NUMBER FORMAT OF 10120128-XXXX, WHERE: "X" DENOTES MODULE TYPE PER CHART ON THIS SHEET "YYYY" IS A SEQUENTIAL NUMBER BEGINNING WITH "0001".

MODULE DESCRIPTION	LETTER DESIGNATION REPRESENTED IN DASH NUMBER										BASE MODULE
	N	J	A	B	C	D	E	F	G	H	
LEFT POLARIZING GUIDANCE MODULE (SEE SHEET 6)	NO KEY NO GUIDE PIN										
RIGHT POLARIZING GUIDANCE MODULE (SEE SHEET 7)	NO KEY NO GUIDE PIN										
OPEN MODULE (TWO WALL) (SEE SHEET 2)	0 (ZERO)										
LEFT WALL MODULE (SEE SHEET 3)	L										
RIGHT WALL MODULE (SEE SHEET 4)	M										
FOUR WALL MODULE (SEE SHEET 5)	1 (ONE)										

	UNGROUND	GROUND
FHS	Ø2.35-Ø2.55	Ø2.35-Ø2.55
PAD	N/A	Ø5.50
PLATED	NO	YES
DRILL (mm)	2.44mm	2.58mm
DRILL (in)	0.096"	0.1015"

SCREW P/N	DESCRIPTION	BOARD THICKNESS
10091790-002LF	#2-56 X 0.375" LG. PHILIPS PANHEAD W/SQ CONICAL WASHER	1.60-5.00mm
10091790-003LF	#2-56 X 0.375" LG. PHILIPS PANHEAD W/SQ CONICAL WASHER	5.00-10.00mm

spec ref	tolerance std	TOLERANCES UNLESS OTHERWISE SPECIFIED		
ISO 406	ISO 1101	linear	0.X	±0.3
			0.XX	±0.10
			0.XXX	±0.050
ISO 1302		angular	0°	±2°

dr	Yong-Keat Lim	2012/03/01	projection	mm	size	A2	scale	1:1
eng	Sandar Soe	2016/03/08		mm	ecn no	ELX-S-17624-1	rel level	Released
chr	-	-						
appr	Chen-Hong Tan	2016/03/17	product family	-	cat. no.	-	Product - Customer Drw	sheet 1 of 8
Amphenol FCI		MODULE ASSEMBLY, XCEDE HD			part no.	10120128	rev	C
www.fci.com		Vertical Header, 4 Pair 6 Column						

Amphenol FCI

© 2016 AFCI

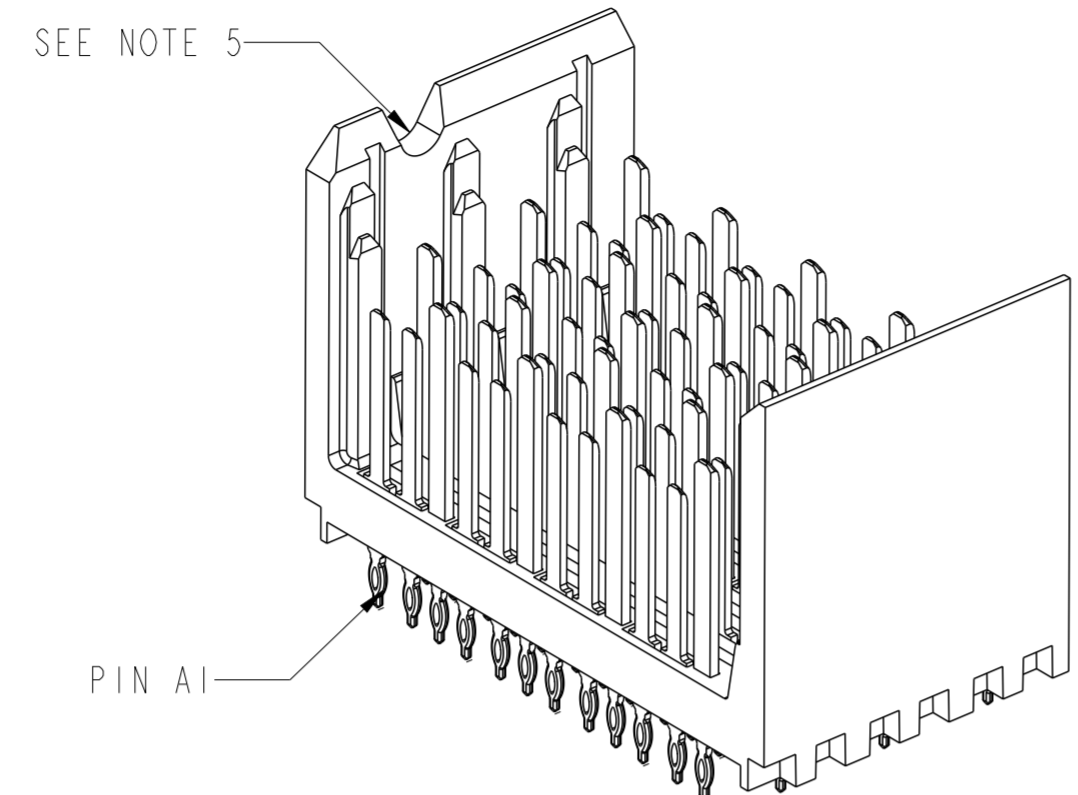
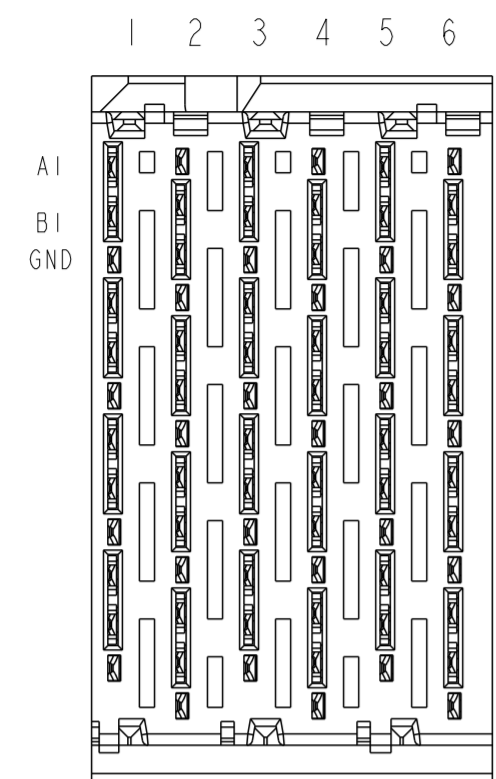

OPEN WALL MODULE

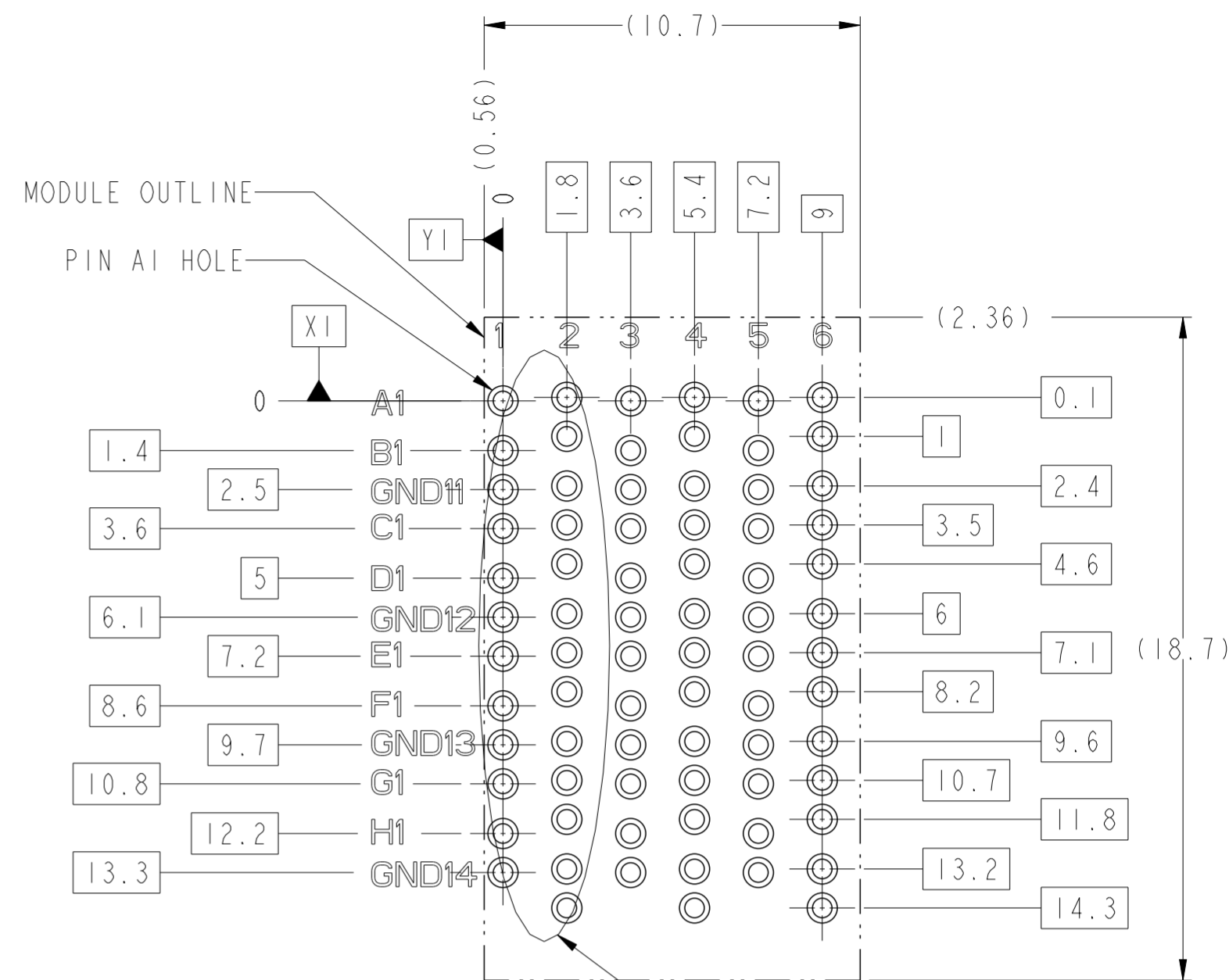

SEE DETAIL A
ON SHEET 8 FOR DETAILS

BP HOLE PATTERN COMPONENT SIDE

OPEN WALL MODULE BACKPLANE FOOTPRINT

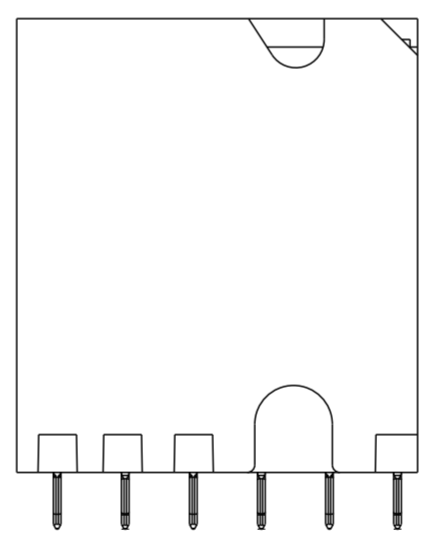
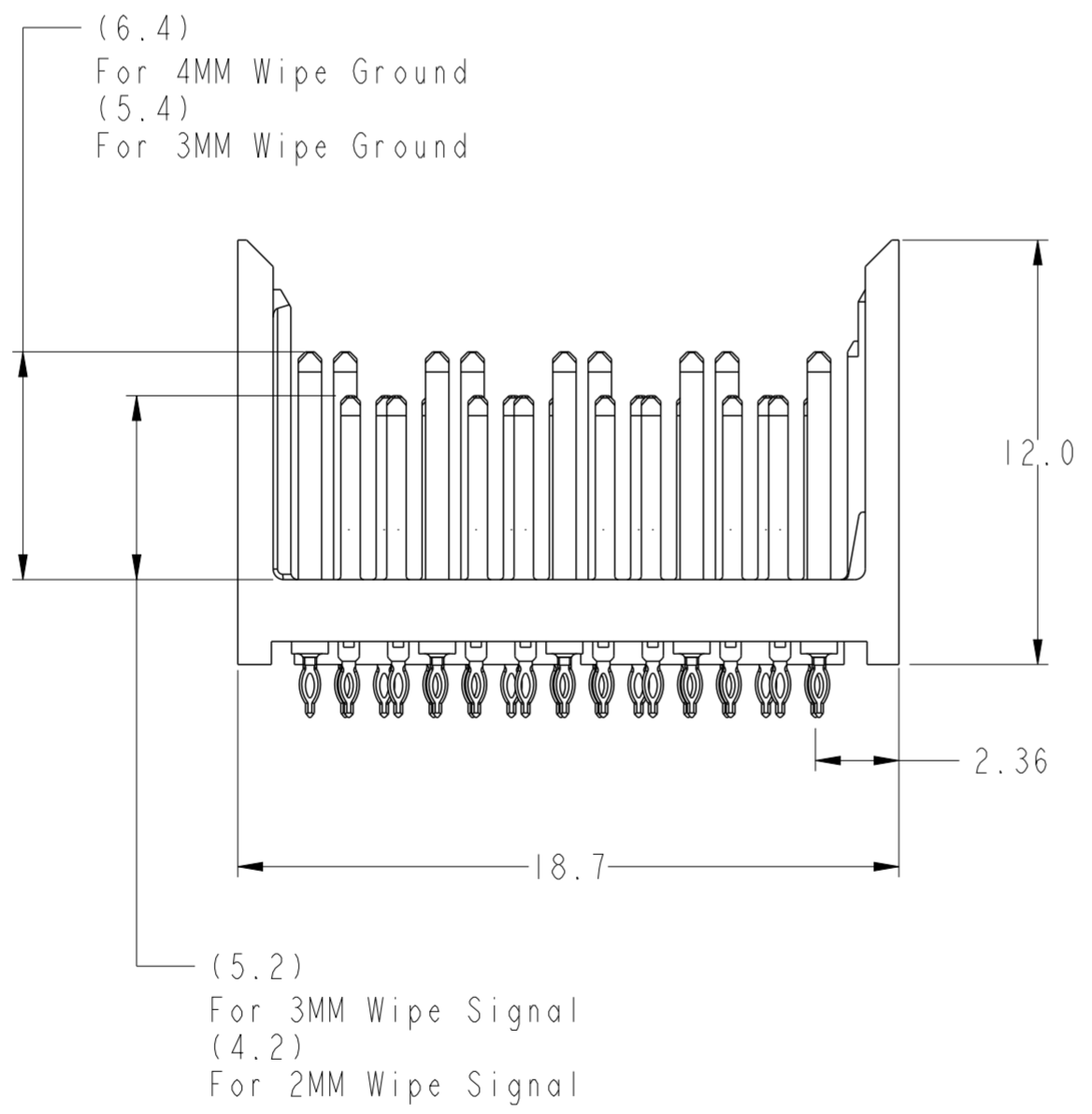
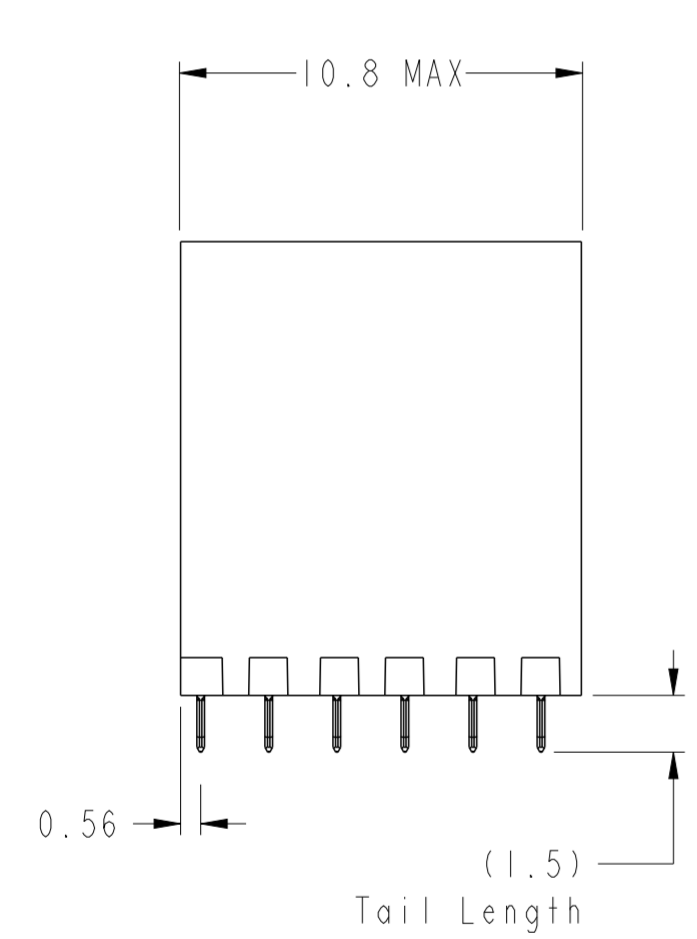

Amphenol
FCi

© 2016 AFci

spec ref	-	dr	Yong-Keat Lim	2012/03/01	projection	mm	size	A2	scale	2:1
tolerance std	ISO 406 ISO 1101	eng	Sandar Soe	2016/03/08		mm	ecn no	ELX-S-17624-1	rel level	Released
TOLERANCES UNLESS OTHERWISE SPECIFIED		chr	-	appr						
surface	ISO 1302	linear	0.X	±0.3			title	MODULE ASSEMBLY, XCEDE HD	dwg no	10120128
		angular	0°	±2°	www.fci.com	cat. no.	Product - Customer Drw	rev	C	sheet 2 of 8

PDS: Rev :C

STATUS:Released

Printed: Mar 17, 2016

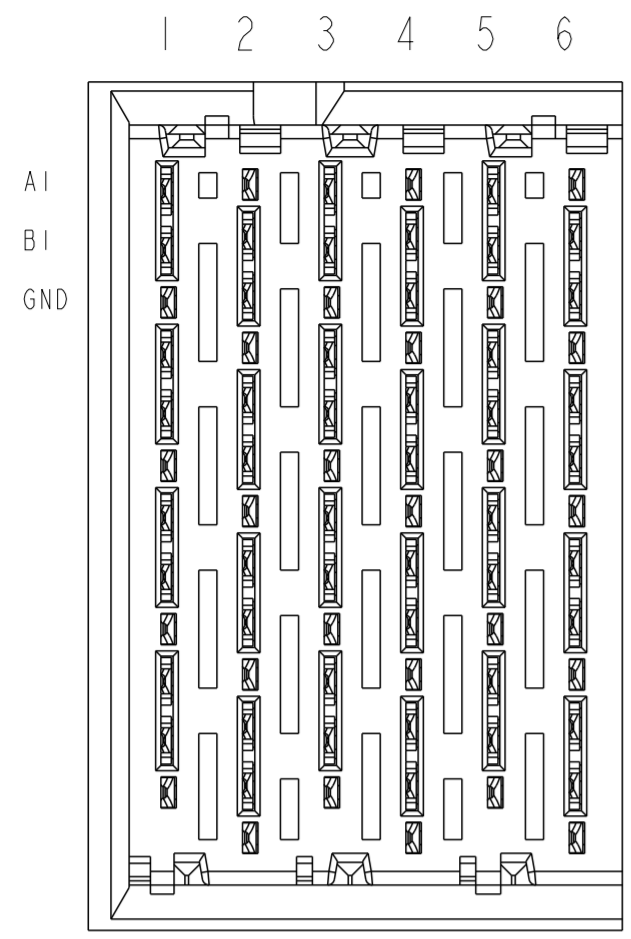

LEFT WALL MODULE

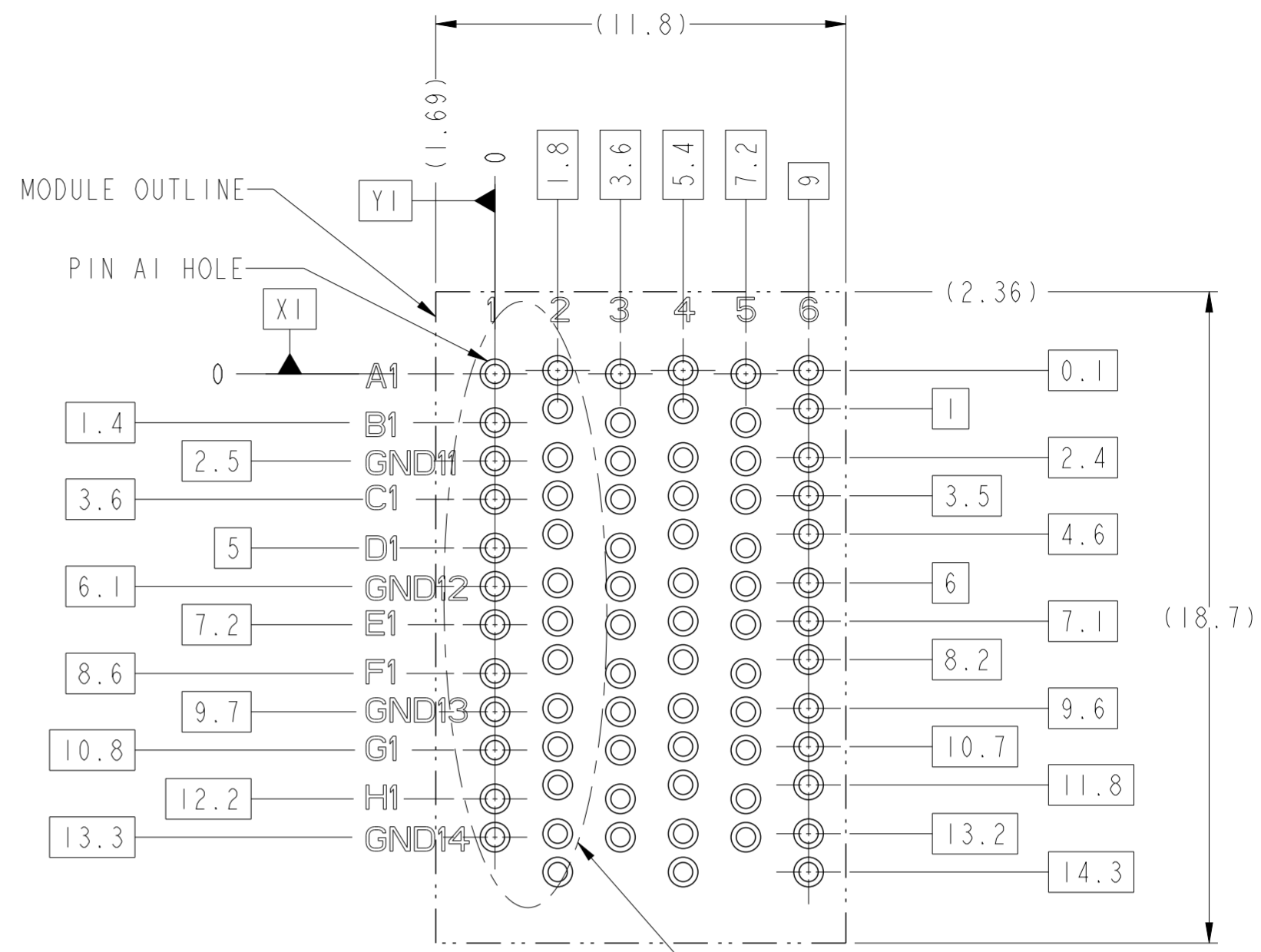
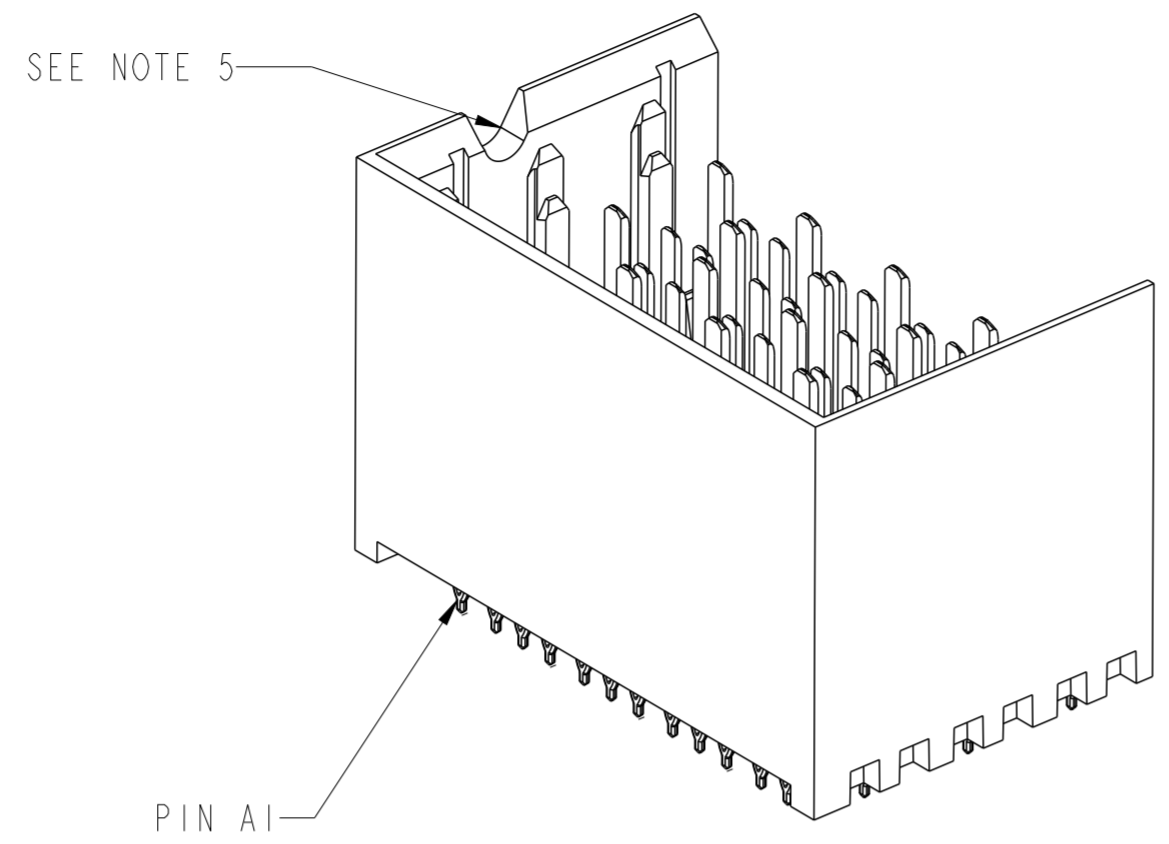

SEE DETAIL A
On Sheet 8 For Details

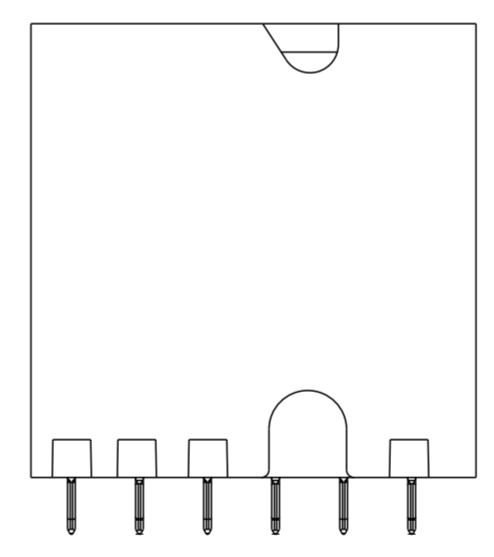
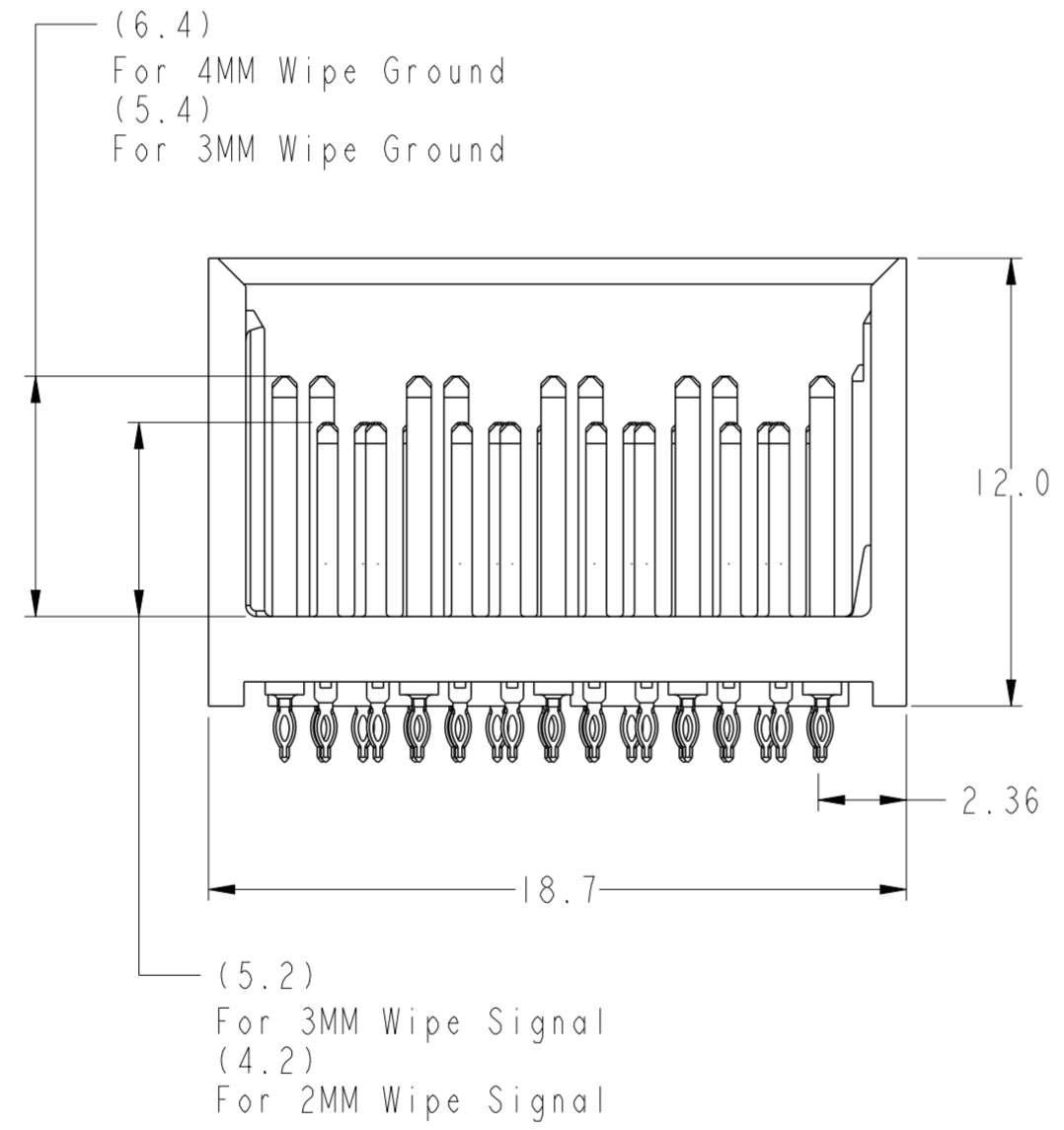
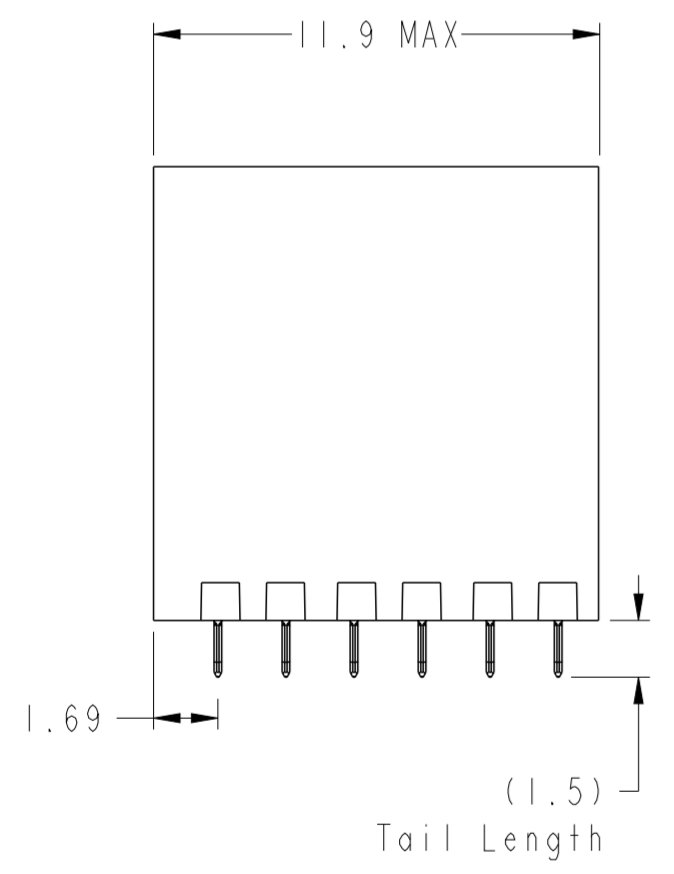

BP HOLE PATTERN COMPONENT SIDE
LEFT WALL MODULE BACKPLANE FOOTPRINT

Amphenol
FCi

© 2016 AFci

spec ref	-	dr	Yong-Keat Lim	2012/03/01	projection	mm	size	A2	scale	2:1	
tolerance std	ISO 406 ISO 1101	eng	Sandar Soe	2016/03/08		mm	ecn no	ELX-S-17624-1	rel level	Released	
TOLERANCES UNLESS OTHERWISE SPECIFIED		chr	-	appr							Chen-Hong Tan
surface	ISO 1302	linear	0.X	±0.3			title	MODULE ASSEMBLY, XCEDE HD	dwg no	10120128	
		angular	0°	±2°	www.fci.com	cat. no.	-	Product - Customer Drw	sheet 3 of 8	rev	C

PDS: Rev :C

STATUS:Released

Printed: Mar 17, 2016

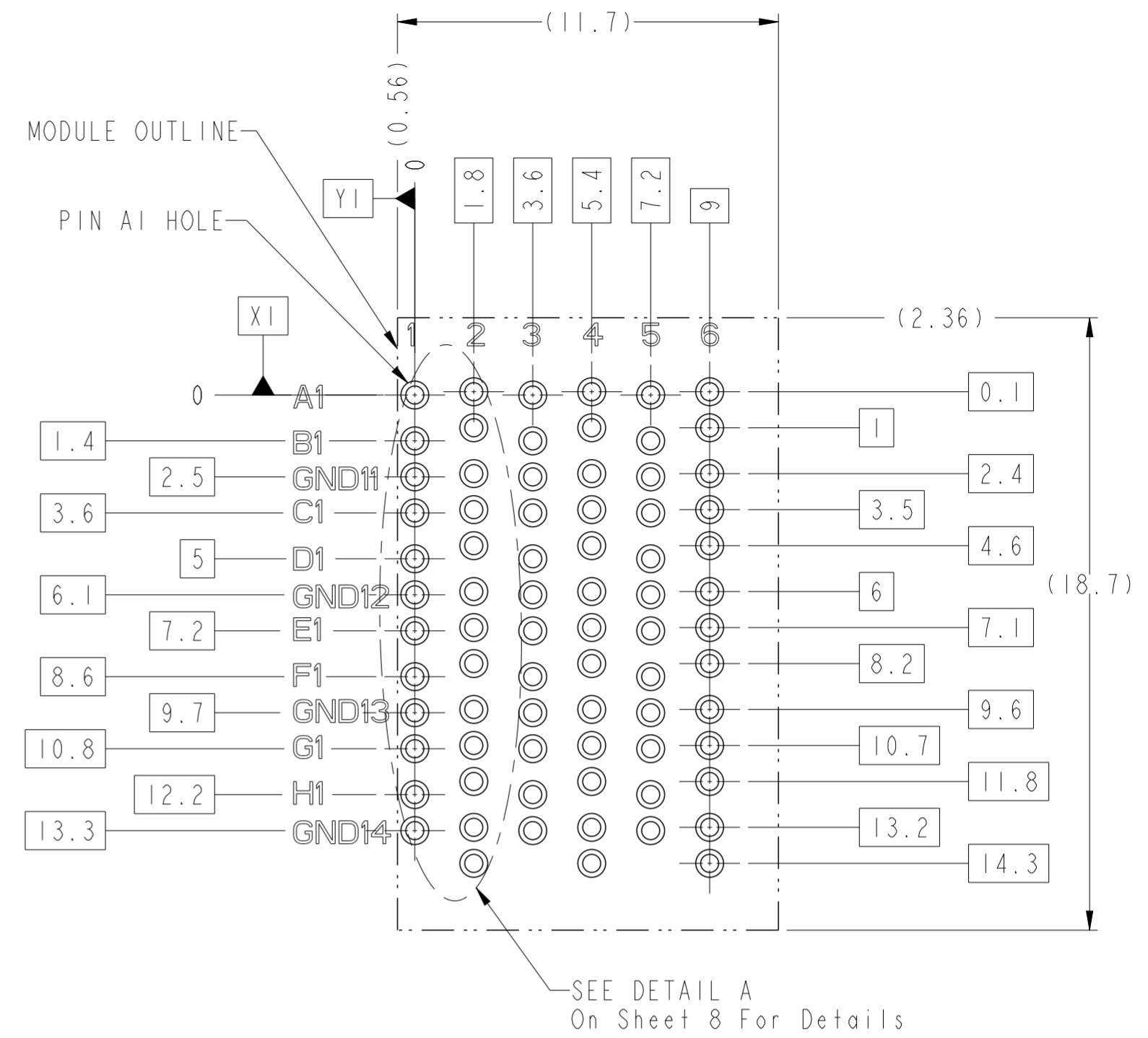
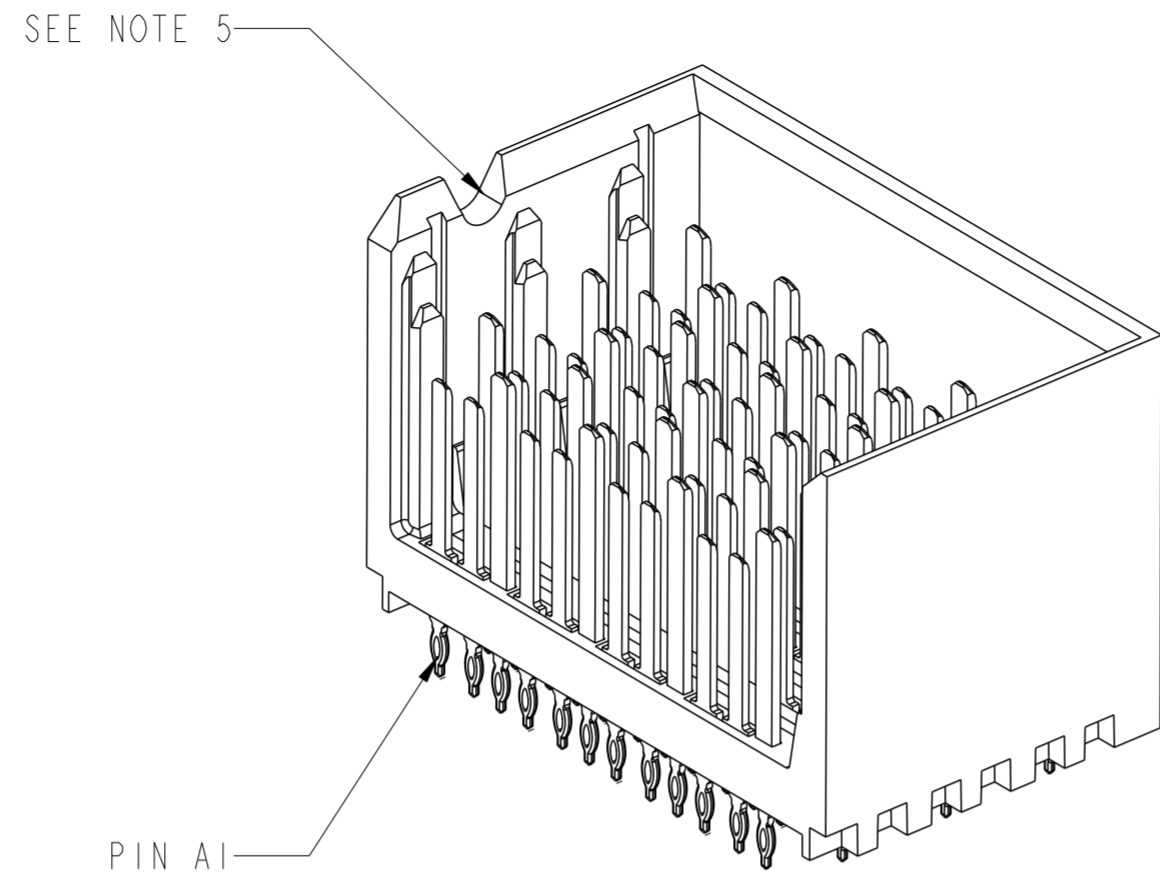
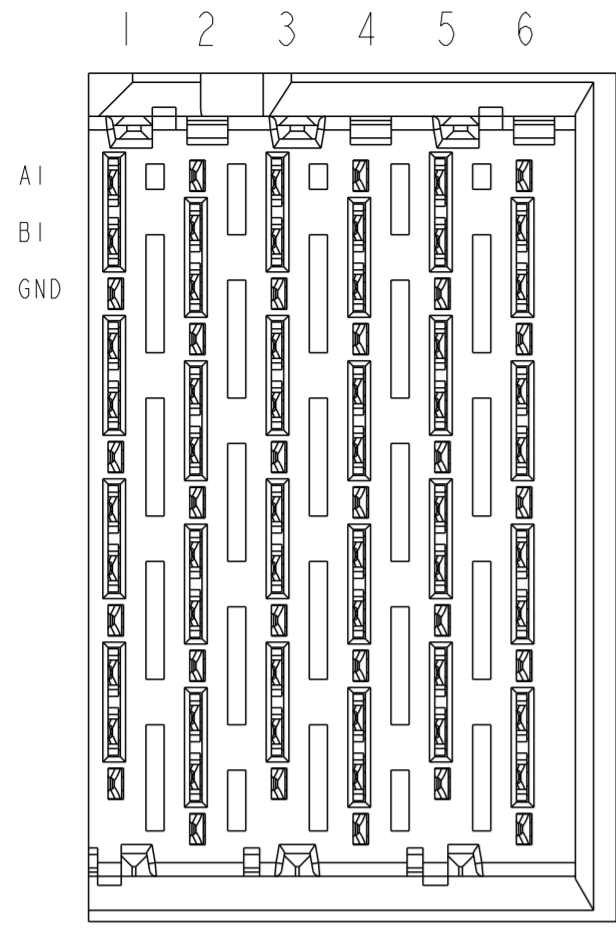

RIGHT WALL MODULE

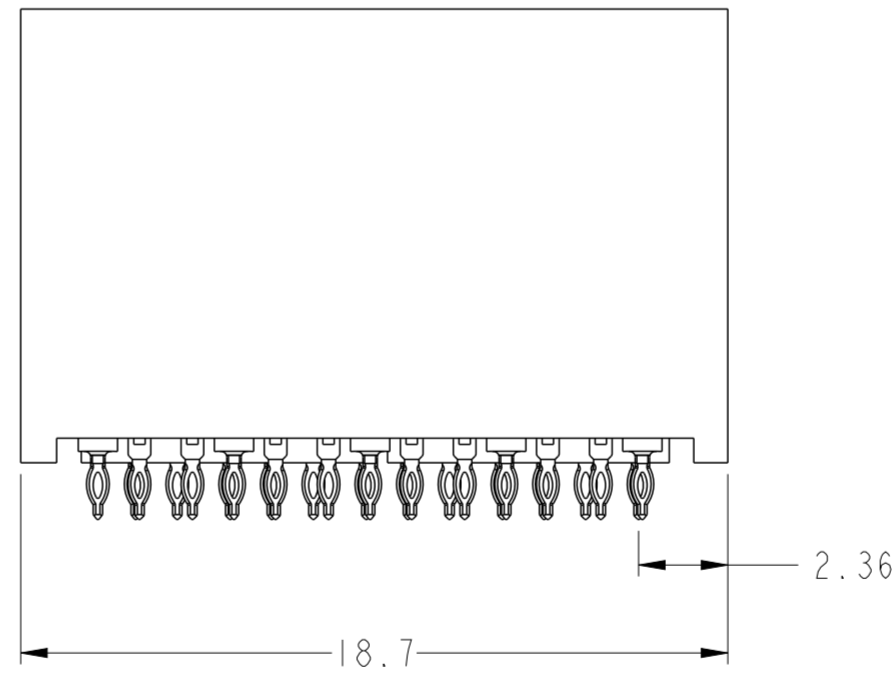
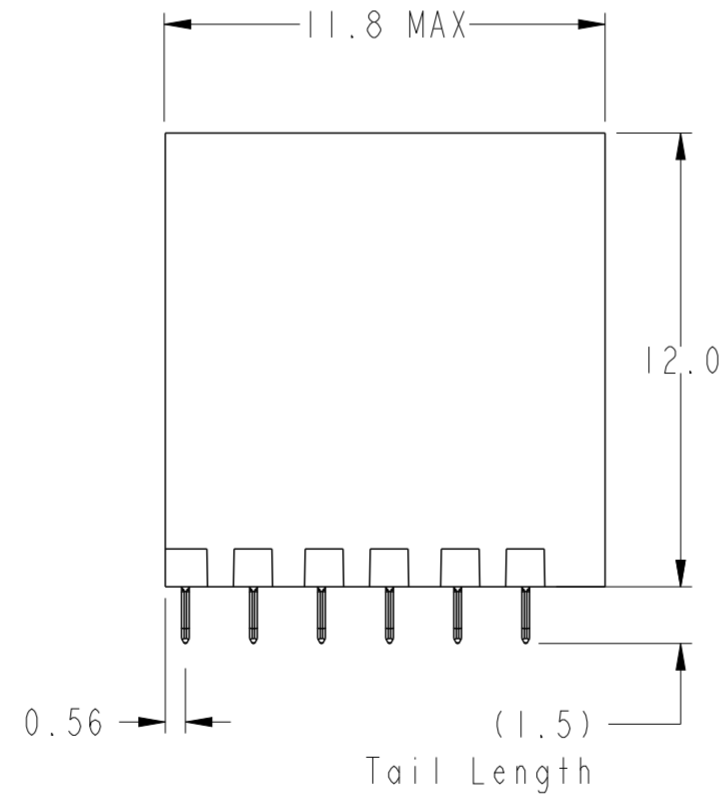
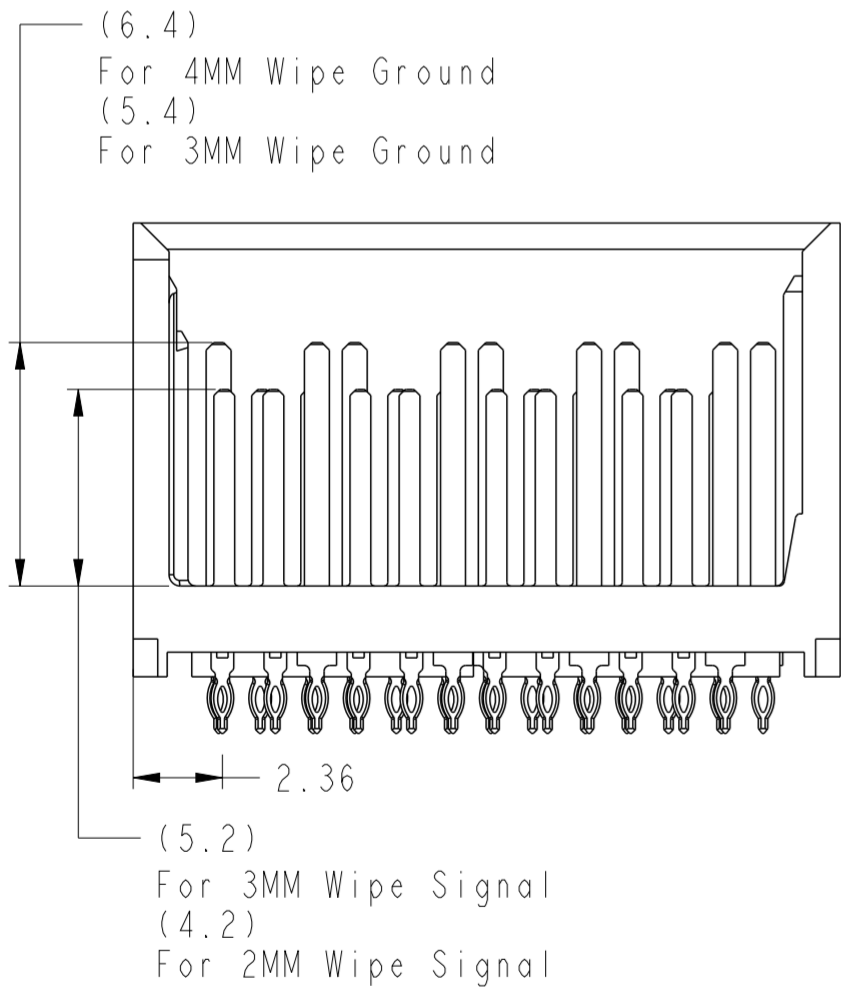

**BP HOLE PATTERN COMPONENT SIDE
RIGHT WALL MODULE BACKPLANE FOOTPRINT**

spec ref	-	dr	Yong-Keat Lim	2012/03/01	projection	mm	size	A2	scale	2:1	
tolerance std	ISO 406 ISO 1101	eng	Sandar Soe	2016/03/08		mm	ecn no	ELX-S-17624-1	rel level	Released	
TOLERANCES UNLESS OTHERWISE SPECIFIED		chr	-	appr							Chen-Hong Tan
surface	ISO 1302	linear	0.X	±0.3			title	MODULE ASSEMBLY, XCEDE HD		rev	C
			0.XX	±0.10	www.fci.com	cat. no.		Product - Customer Drw	sheet 4 of 8		
		angular	0°	±2°							

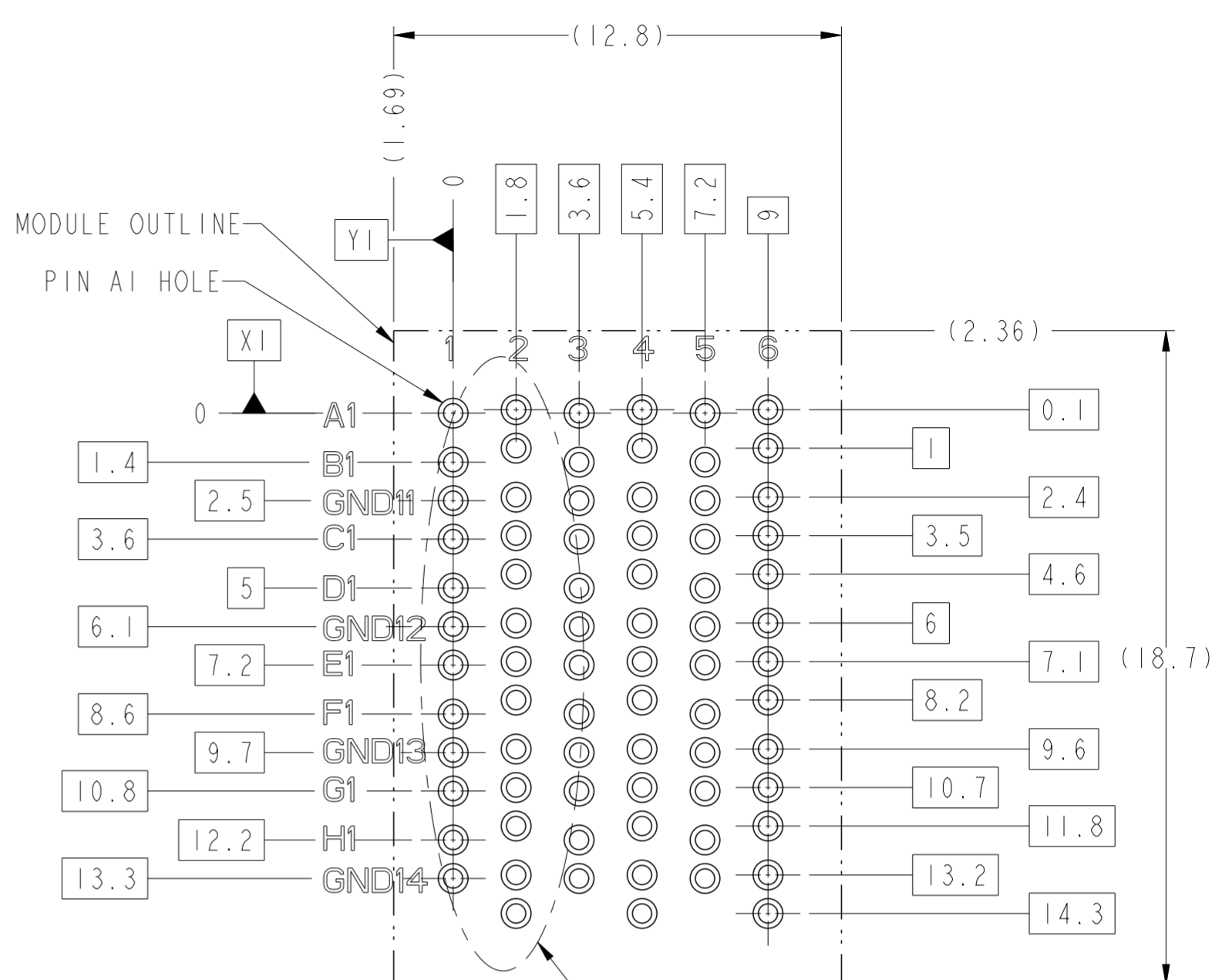
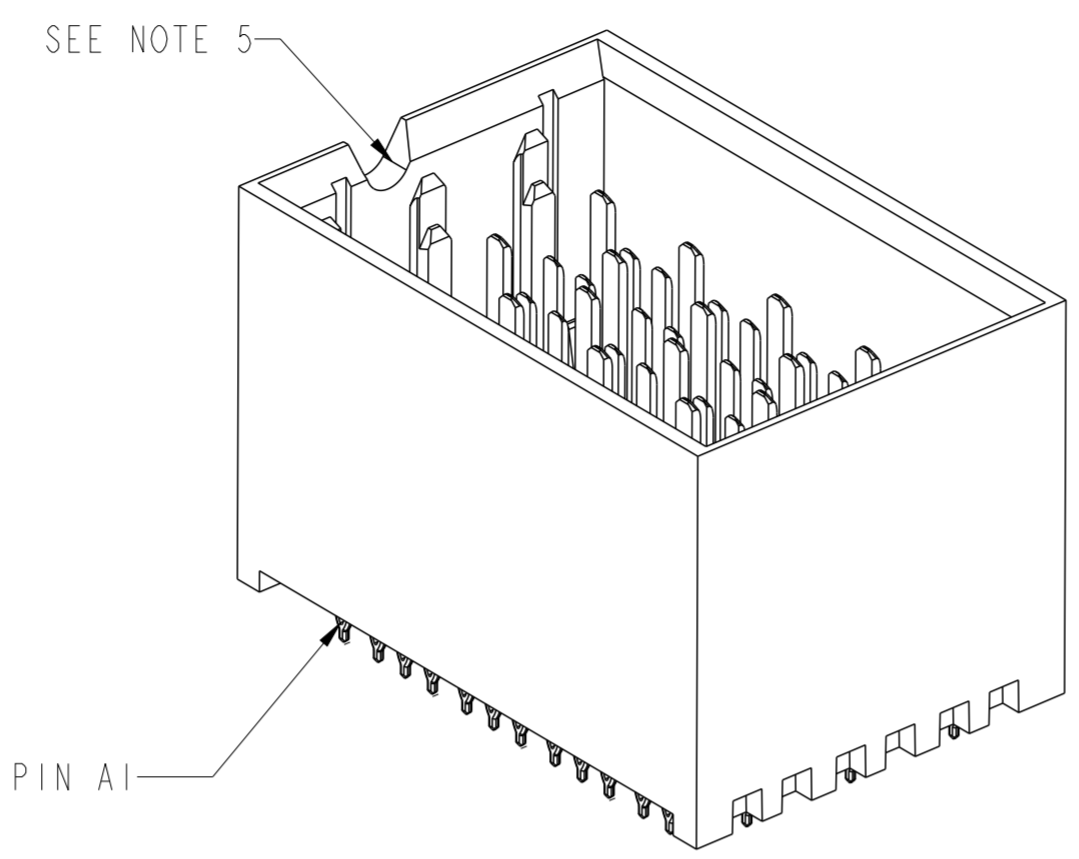
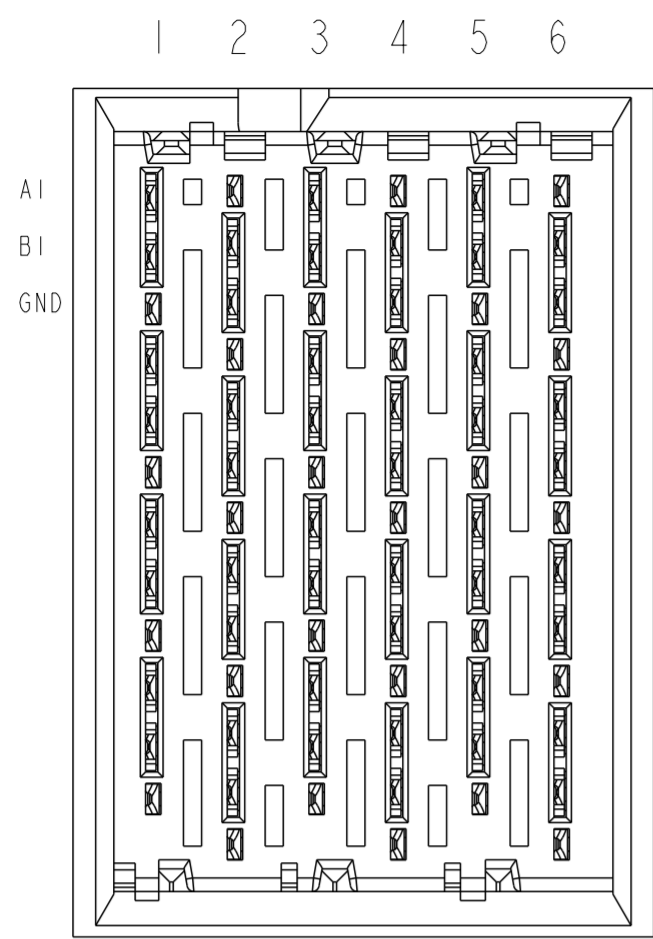

△ FOUR WALL MODULE

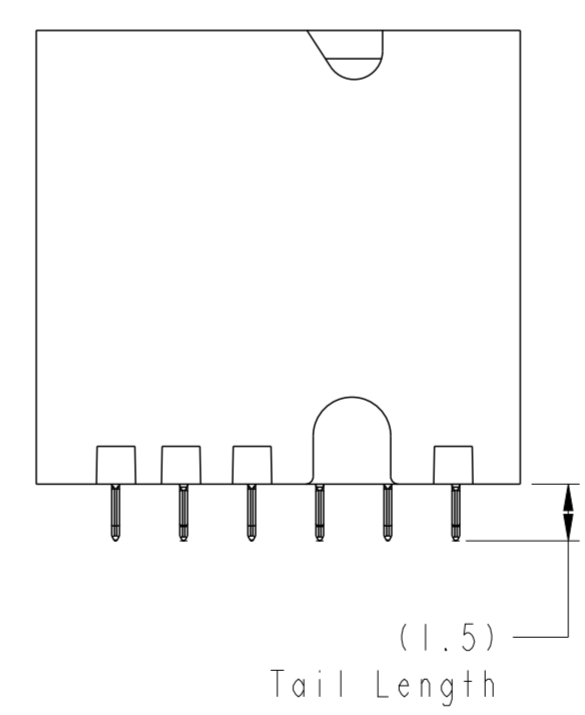
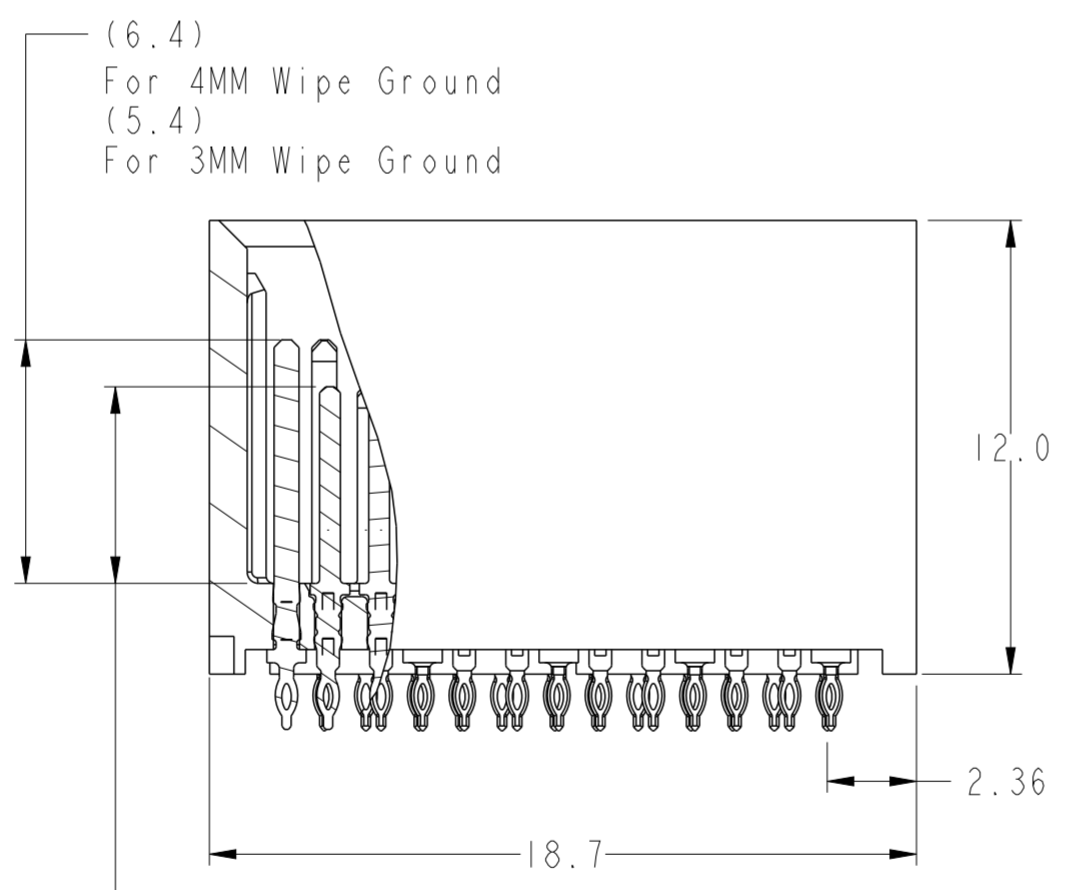
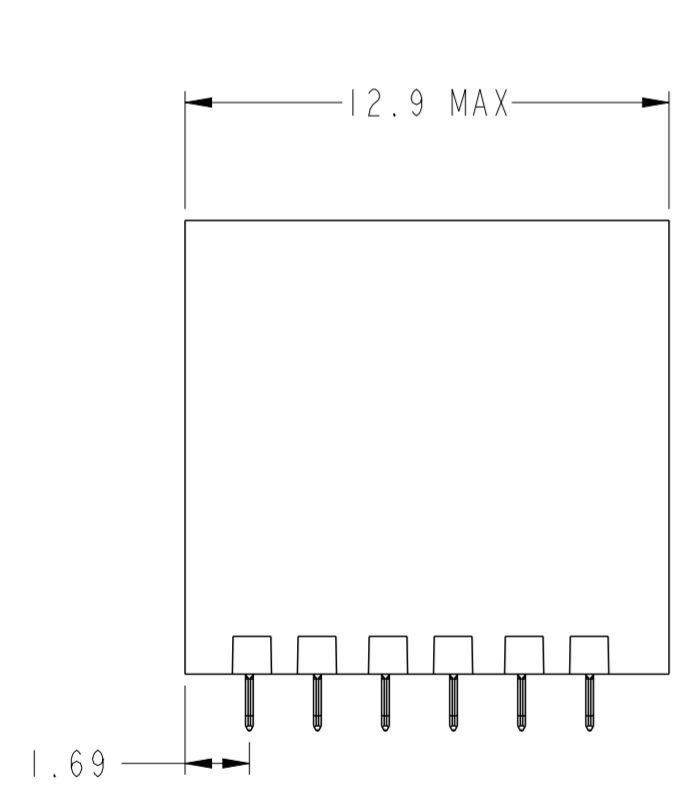

BP HOLE PATTERN COMPONENT SIDE
△ FOUR WALL MODULE BACKPLANE FOOTPRINT

spec ref	-	dr	Yong-Keat Lim	2012/03/01	projection	mm	size	A2	scale	2:1	
tolerance std	ISO 406 ISO 1101	eng	Sandar Soe	2016/03/08		mm	ecn no	ELX-S-17624-1	rel level	Released	
TOLERANCES UNLESS OTHERWISE SPECIFIED		chr	-	appr							Chen-Hong Tan
surface	ISO 1302	linear	0.X	±0.3	0.XX	±0.10	0.XXX	±0.050	angular	0°	±2°
www.fci.com		Amphenol FCI		MODULE ASSEMBLY, XCEDE HD		Vertical Header, 4 Pair 6 Column		cat. no.	10120128	rev	C
PDS: Rev :C		STATUS:Released		Product - Customer Drw		sheet 5 of 8		Printed: Mar 17, 2016			

Amphenol FCI

© 2016 AFCI

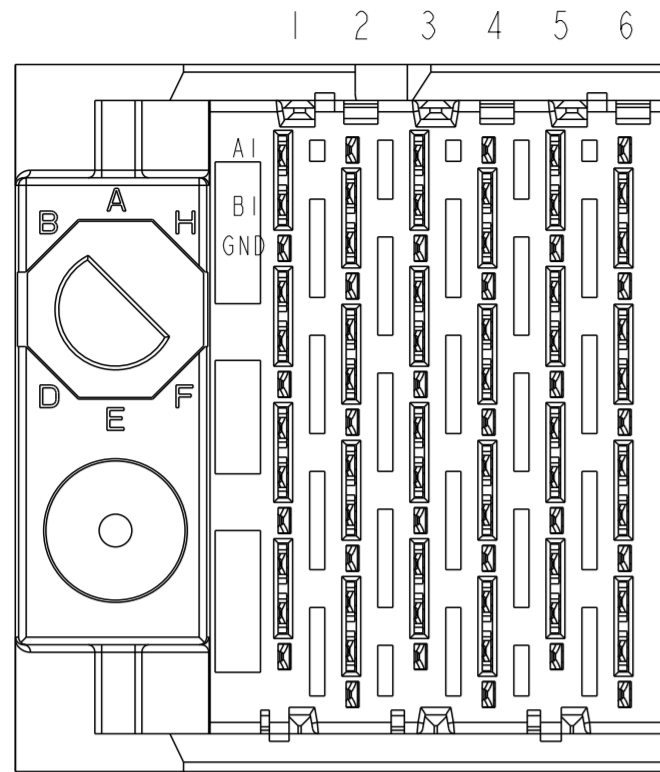

LEFT POLARIZING/GUIDE MODULE

Optional Key See Sheet 1
Part Number Tree

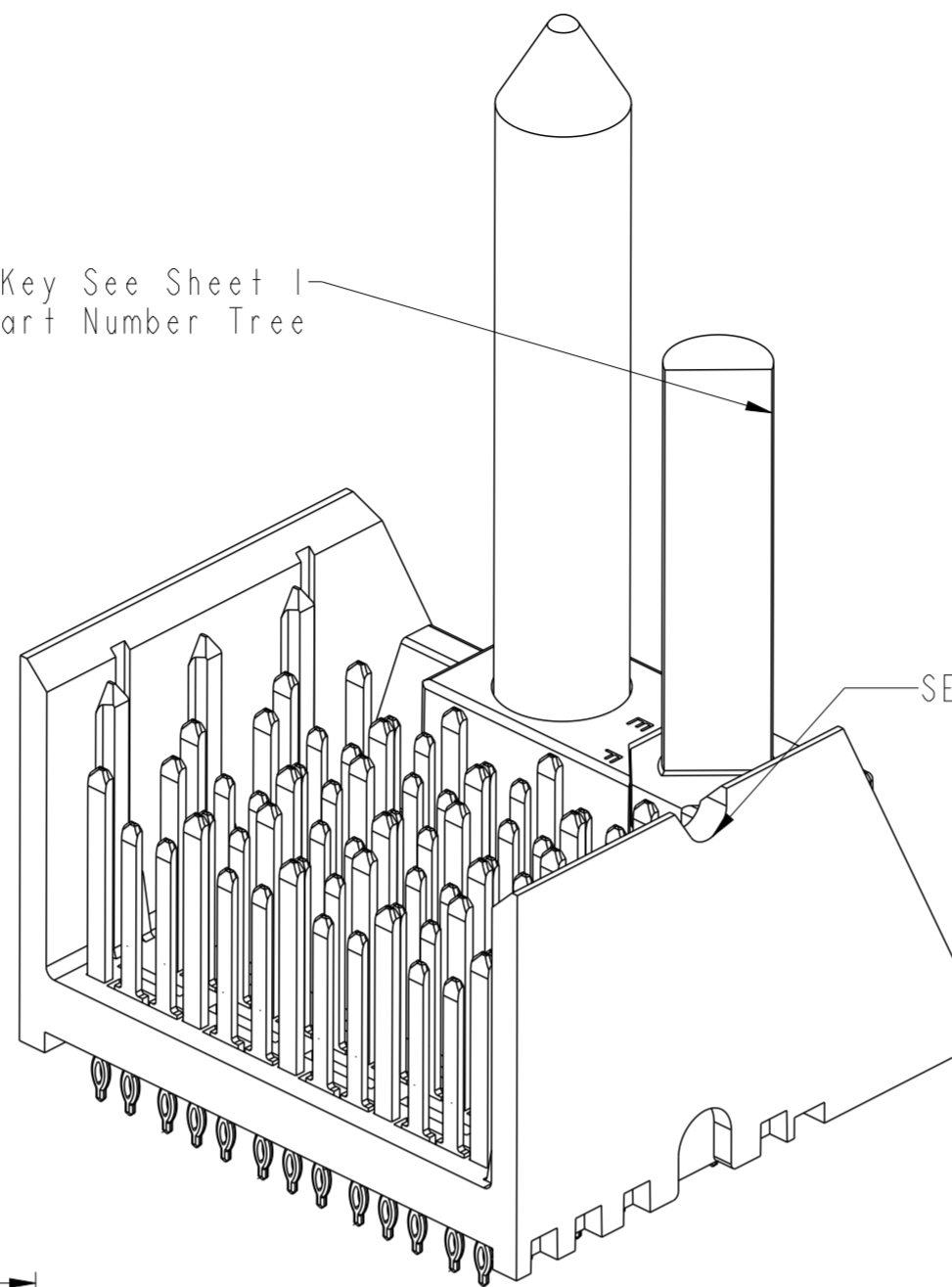

SEE NOTE 5

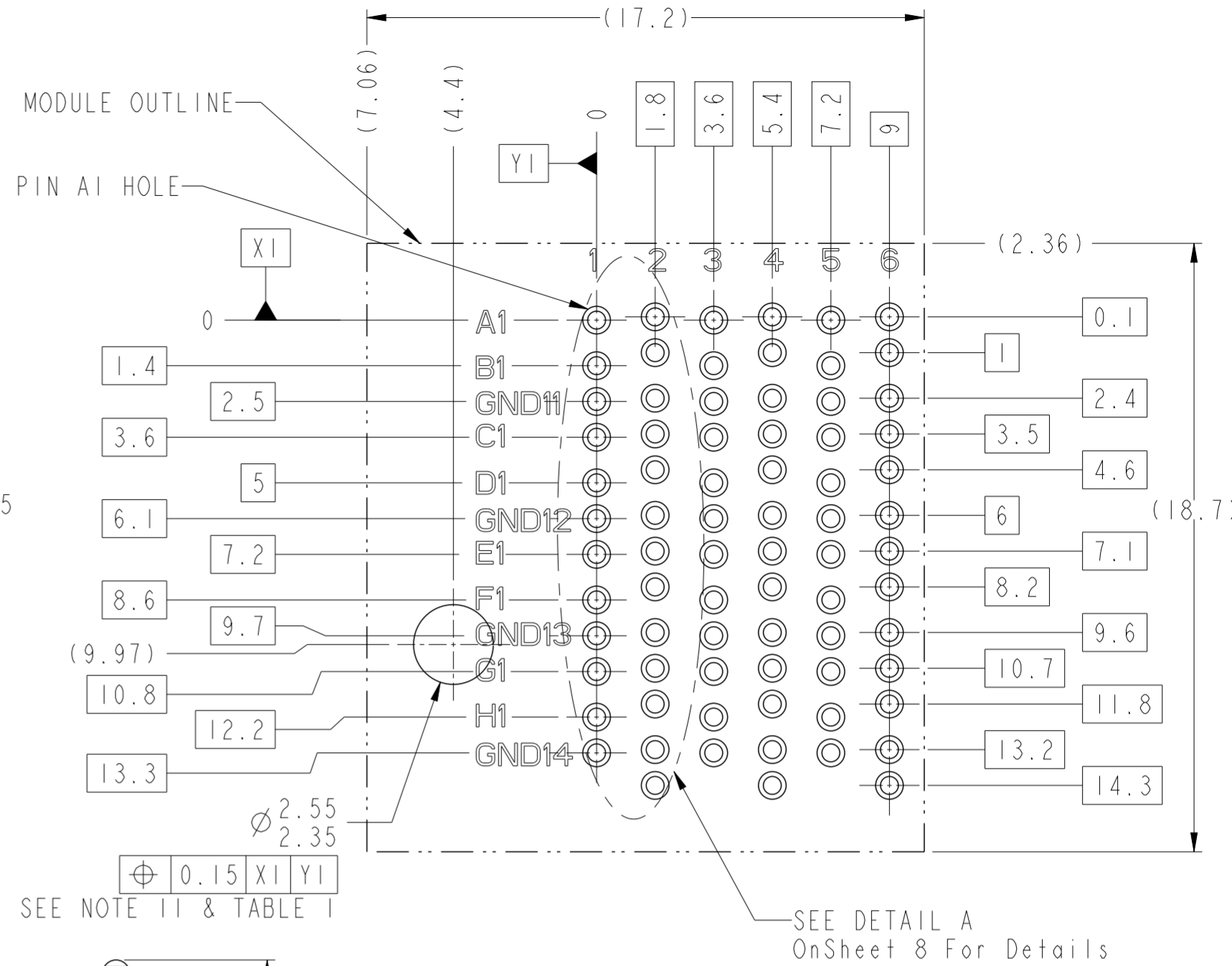

SEE DETAIL A
OnSheet 8 For Details

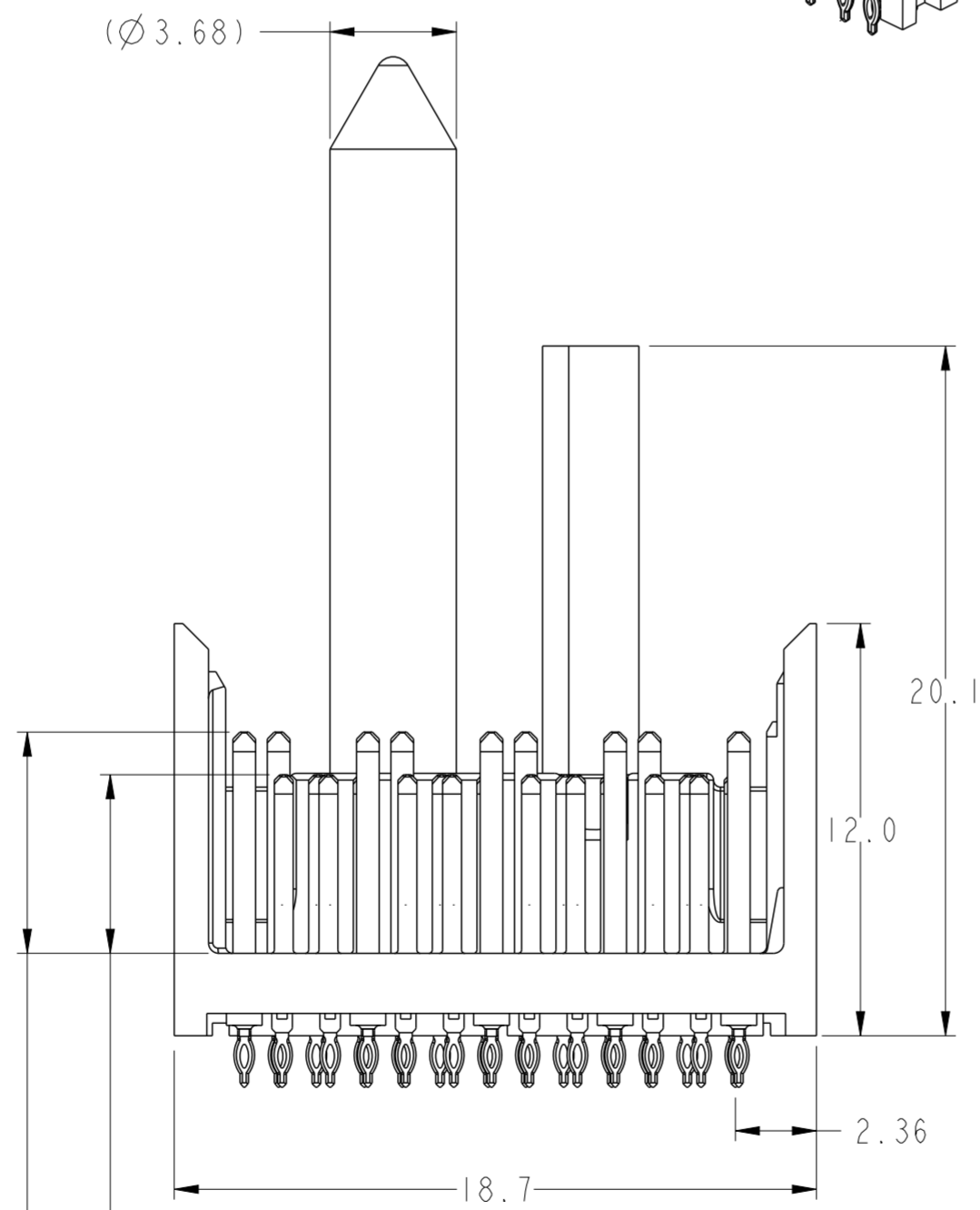
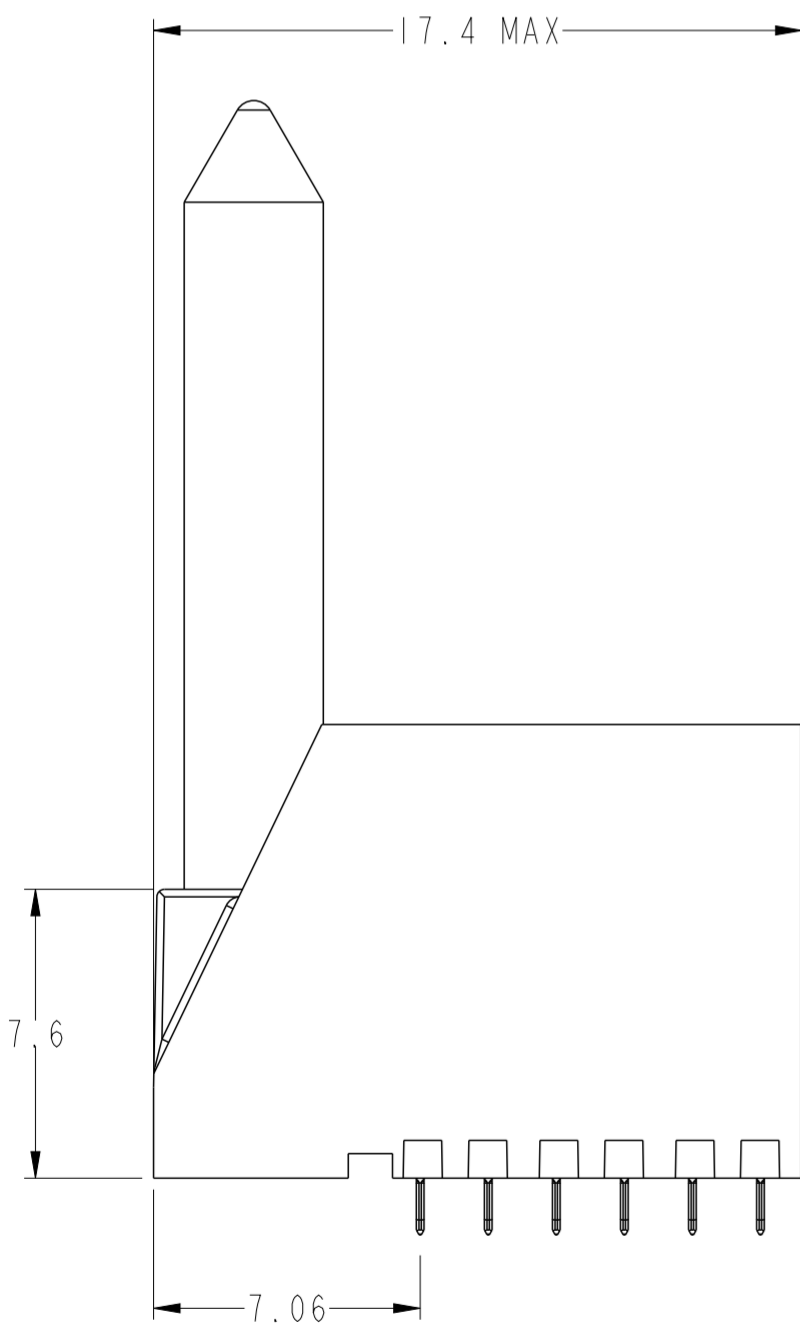

(5.2)
For 3MM Wipe Signal
(4.2)
For 2MM Wipe Signal
(6.4)
For 4MM Wipe Ground
(5.4)
For 3MM Wipe Ground

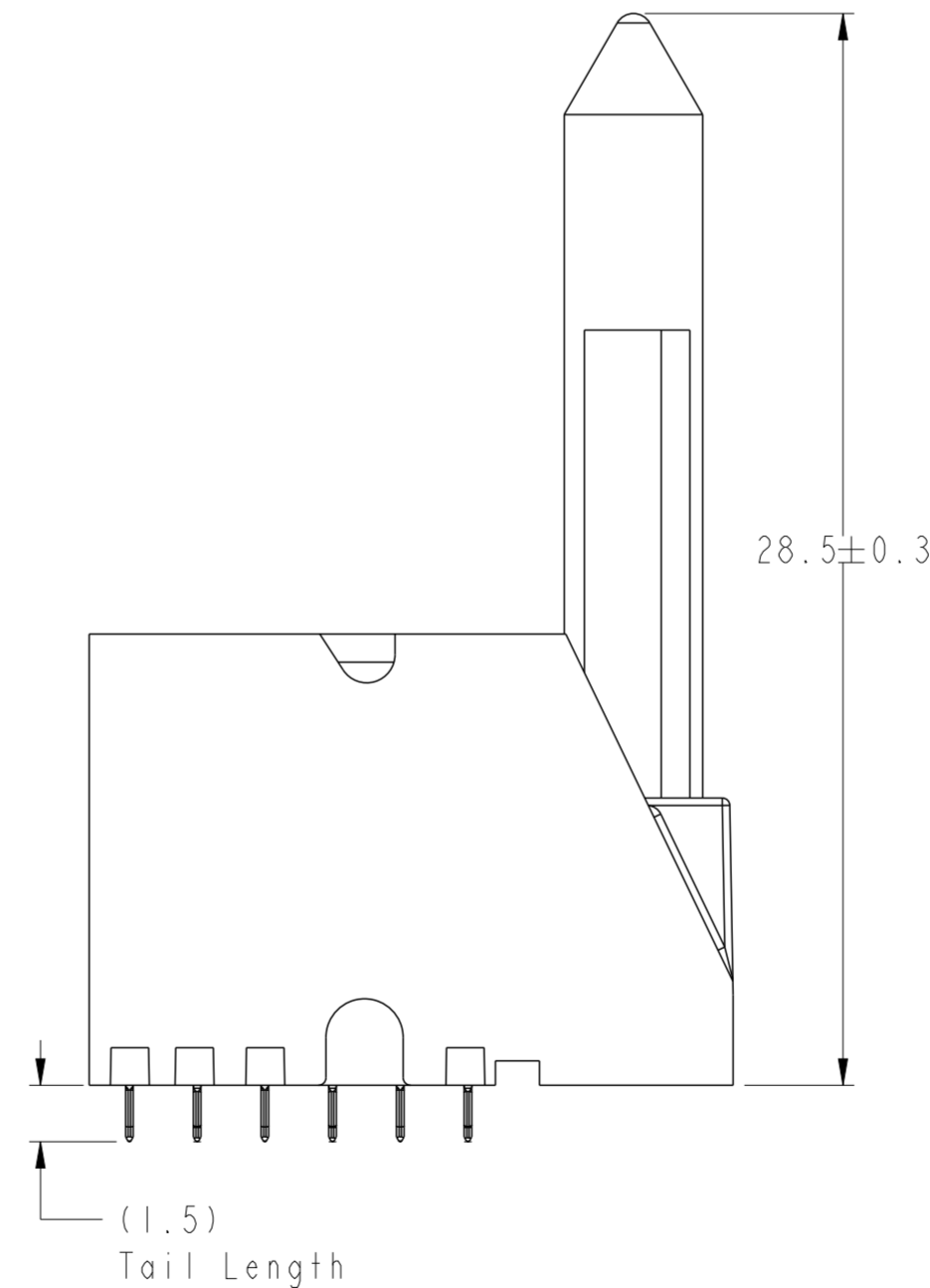

BP HOLE PATTERN COMPONENT SIDE
**LEFT POLARIZING GUIDE MODULE
BACKPLANE FOOTPRINT**

spec ref	-	dr	Yong-Keat Lim	2012/03/01	projection	mm	size	A2	scale	2:1
tolerance std	ISO 406 ISO 1101	eng	Sandar Soe	2016/03/08		mm	ecn no	ELX-S-17624-1	rel level	Released
TOLERANCES UNLESS OTHERWISE SPECIFIED		chr	-	product family						
surface	ISO 1302	appr	Chen-Hong Tan	2016/03/17			cat. no.	10120128	rev	C
linear	0.X ±0.3 0.XX ±0.10 0.XXX ±0.050	Amphenol FCI www.fci.com		MODULE ASSEMBLY, XCEDE HD Vertical Header, 4 Pair 6 Column		Product - Customer Drw	sheet 6 of 8			
angular	0° ±2°	PDS: Rev :C		STATUS:Released		Printed: Mar 17, 2016				

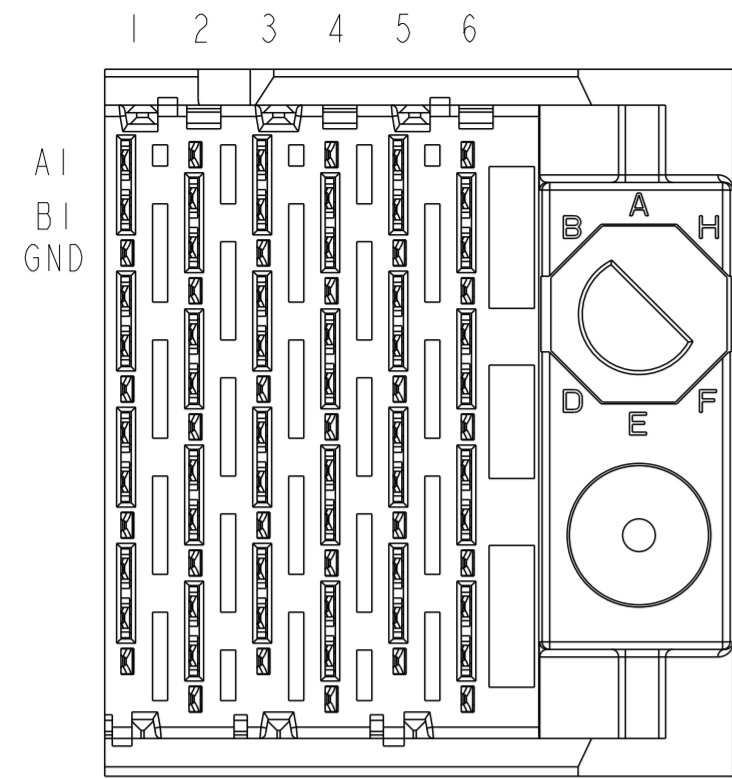

RIGHT POLARIZING/GUIDE MOUDLE

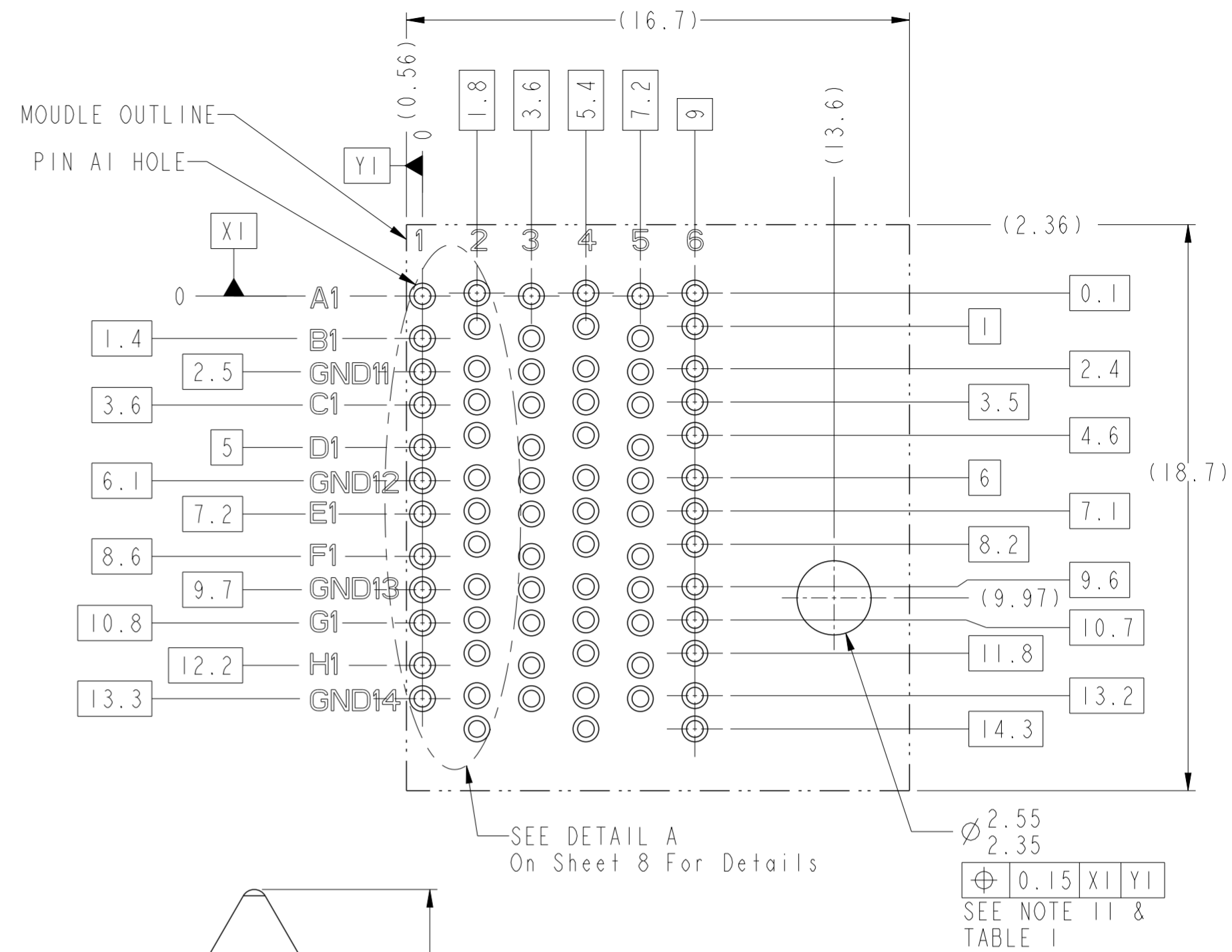
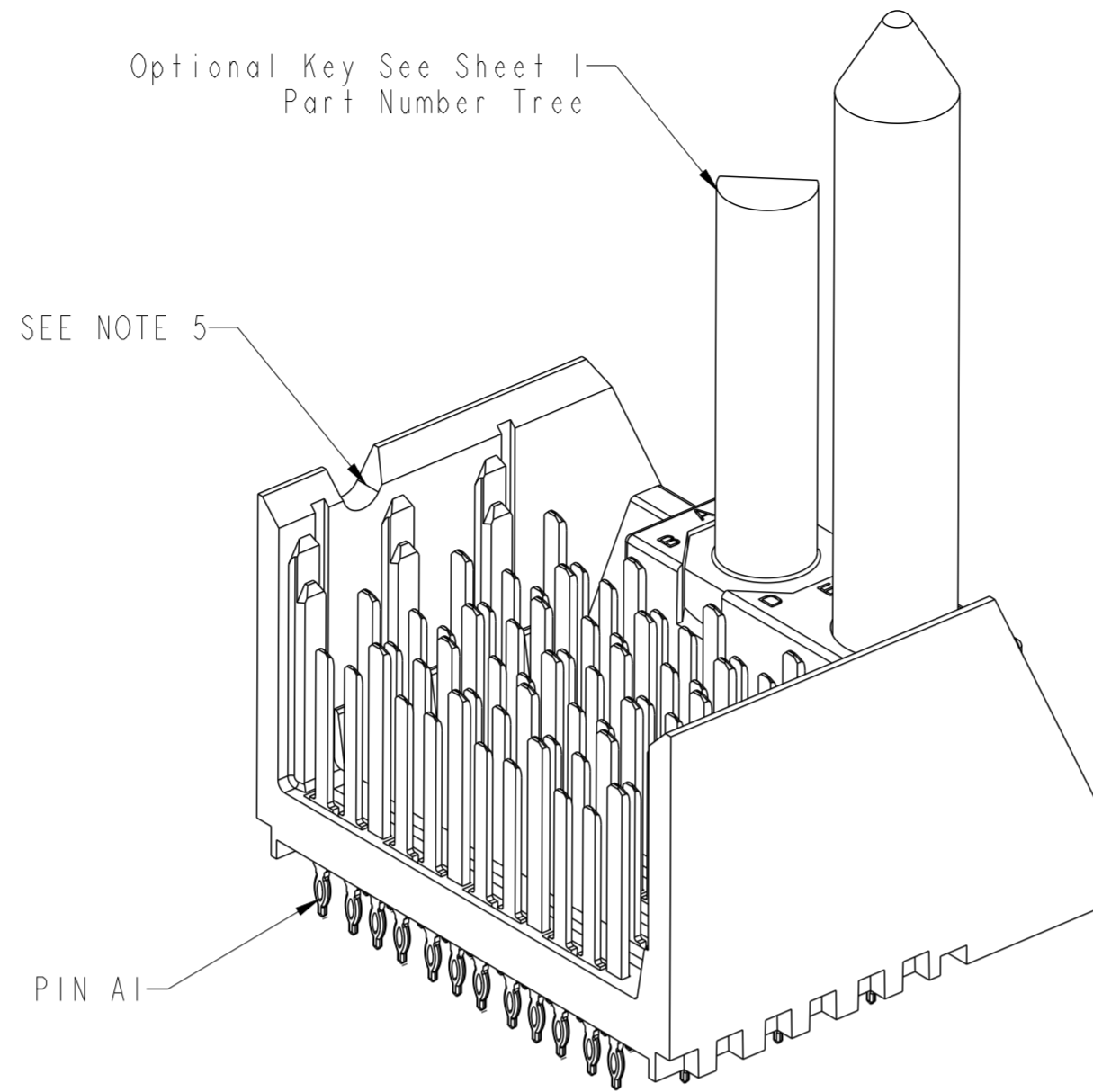

BP HOLE PATTERN COMPONENT SIDE
**RIGHT POLAIZING/GUIDE MODULE
BACKPLANE FOOTPRINT**

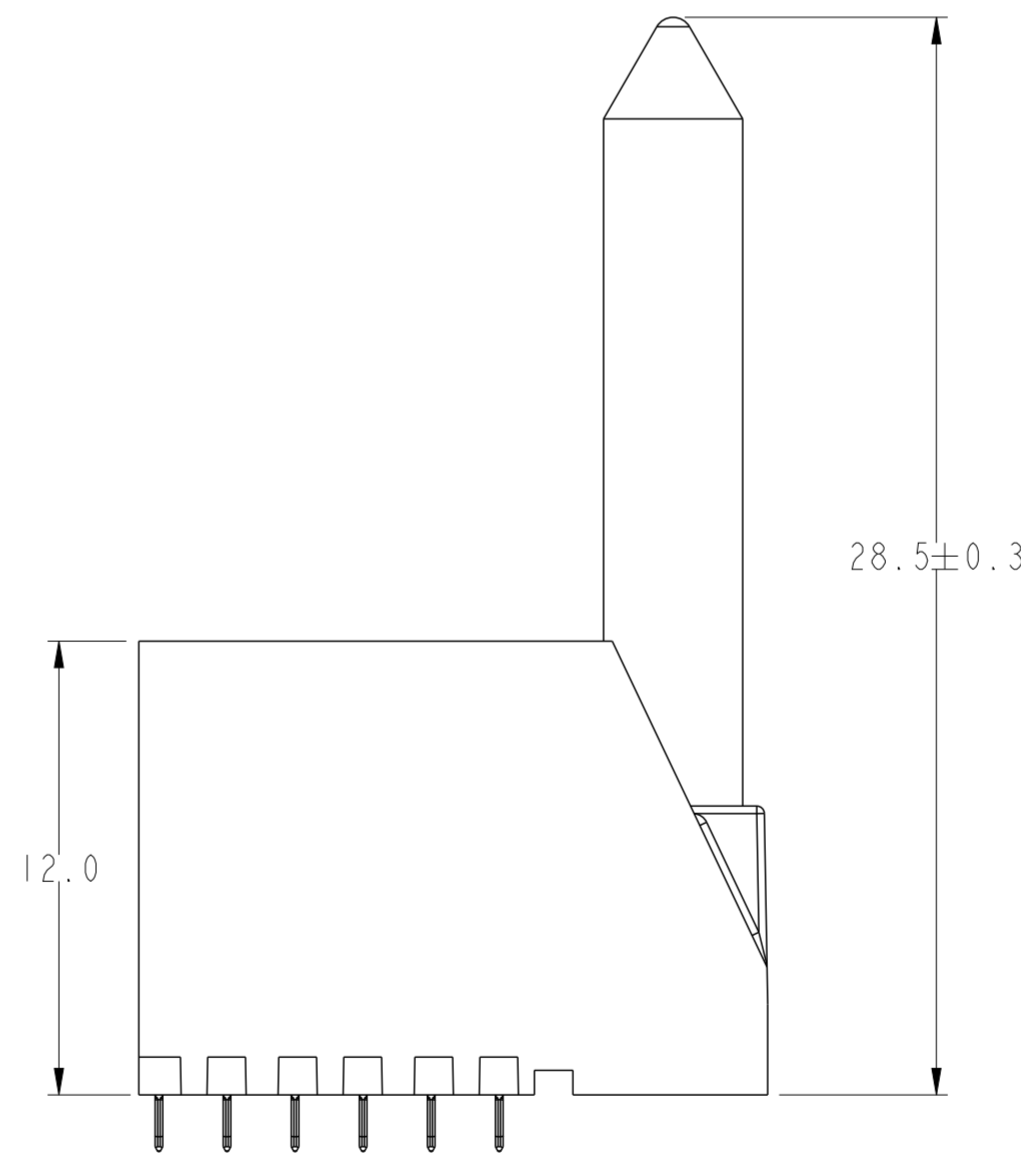
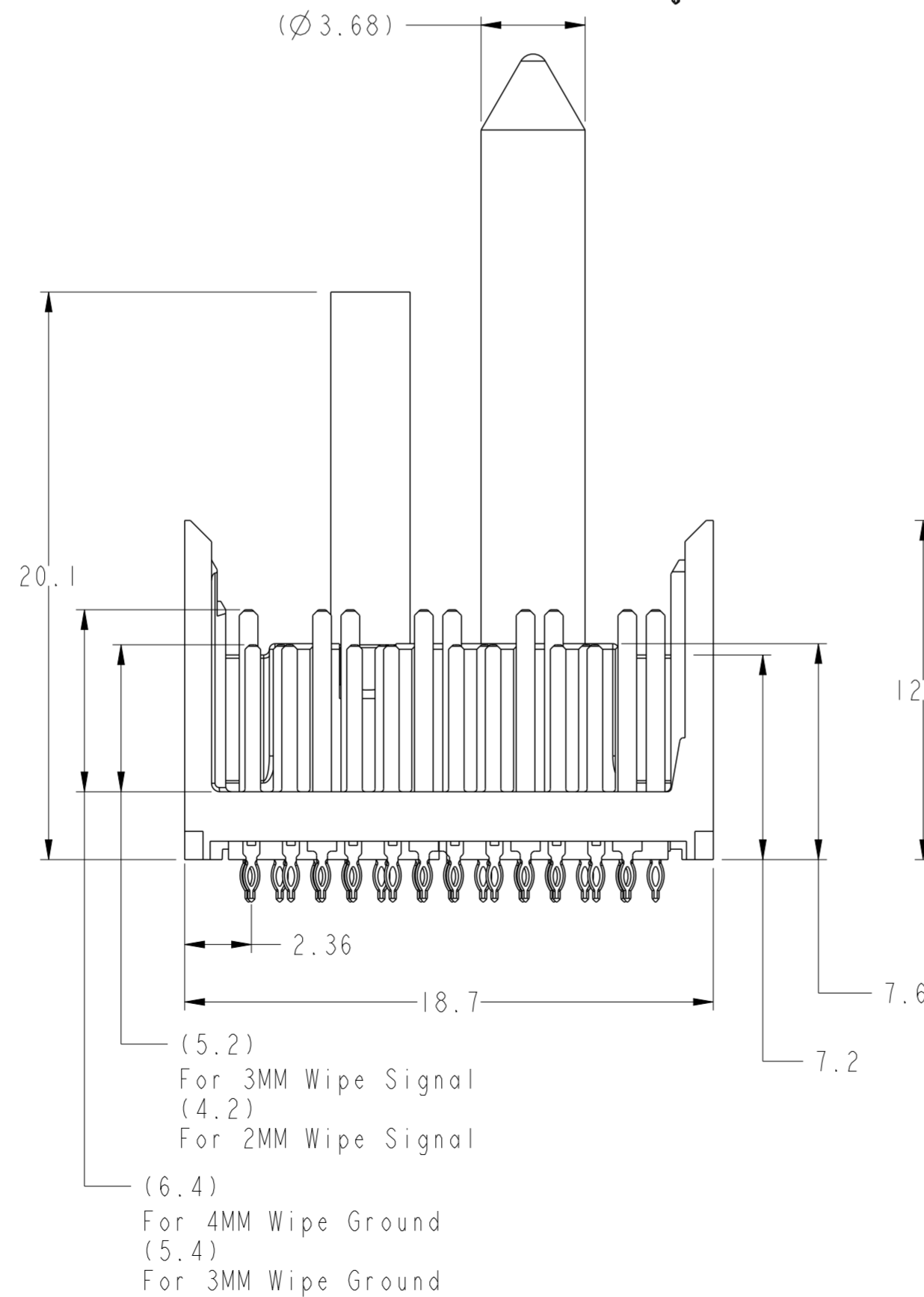
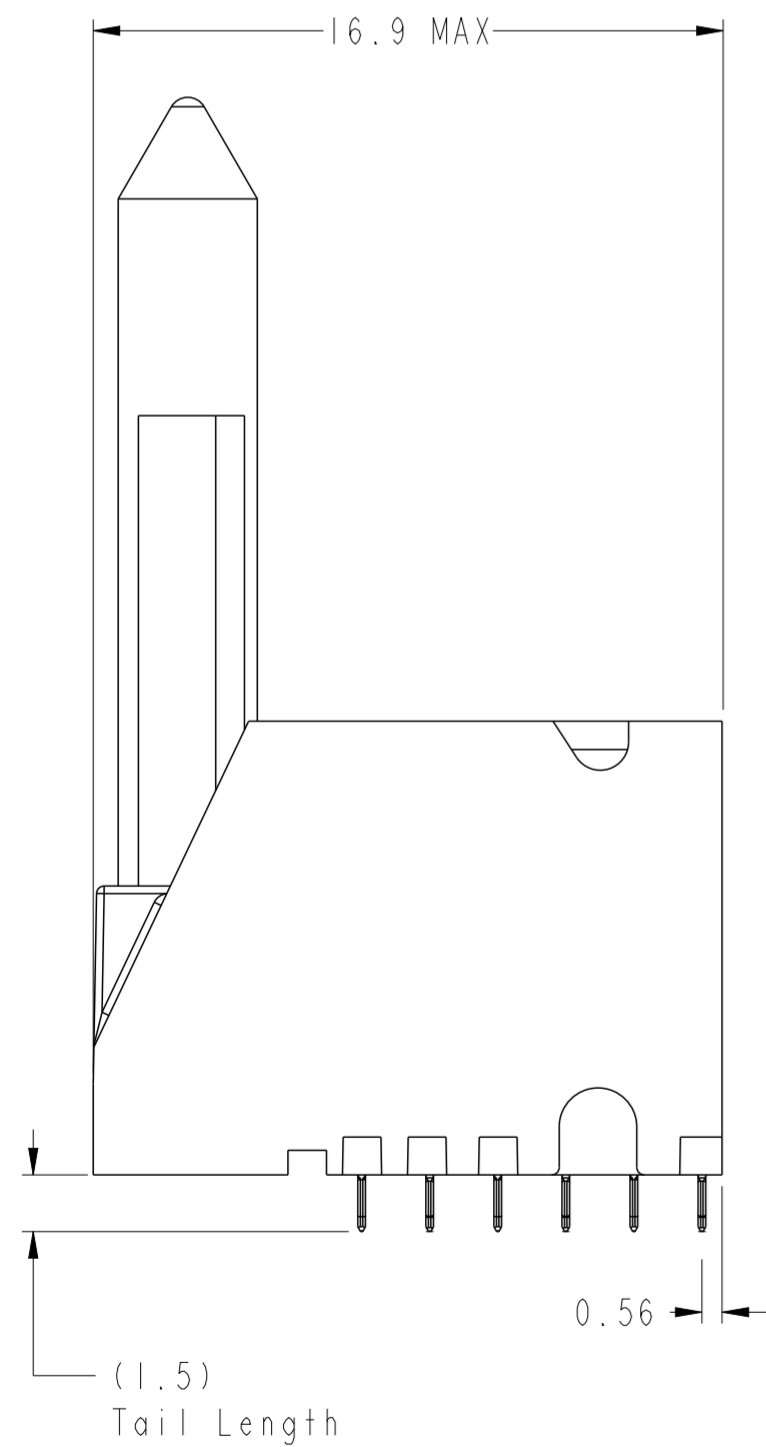

spec ref	-	dr	Yong-Keat Lim	2012/03/01	projection	mm	size	A2	scale	2:1	
tolerance std	ISO 406 ISO 1101	eng	Sandar Soe	2016/03/08		mm	ecn no	ELX-S-17624-1	rel level	Released	
TOLERANCES UNLESS OTHERWISE SPECIFIED		chr	-	appr							Chen-Hong Tan
surface	ISO 1302	linear	0.X	±0.3			title	MODULE ASSEMBLY, XCEDE HD	cat. no.	10120128	
		angular	0°	±2°	www.fci.com		Vertical Header, 4 Pair 6 Column	Product - Customer Drw	sheet 7 of 8	rev	C

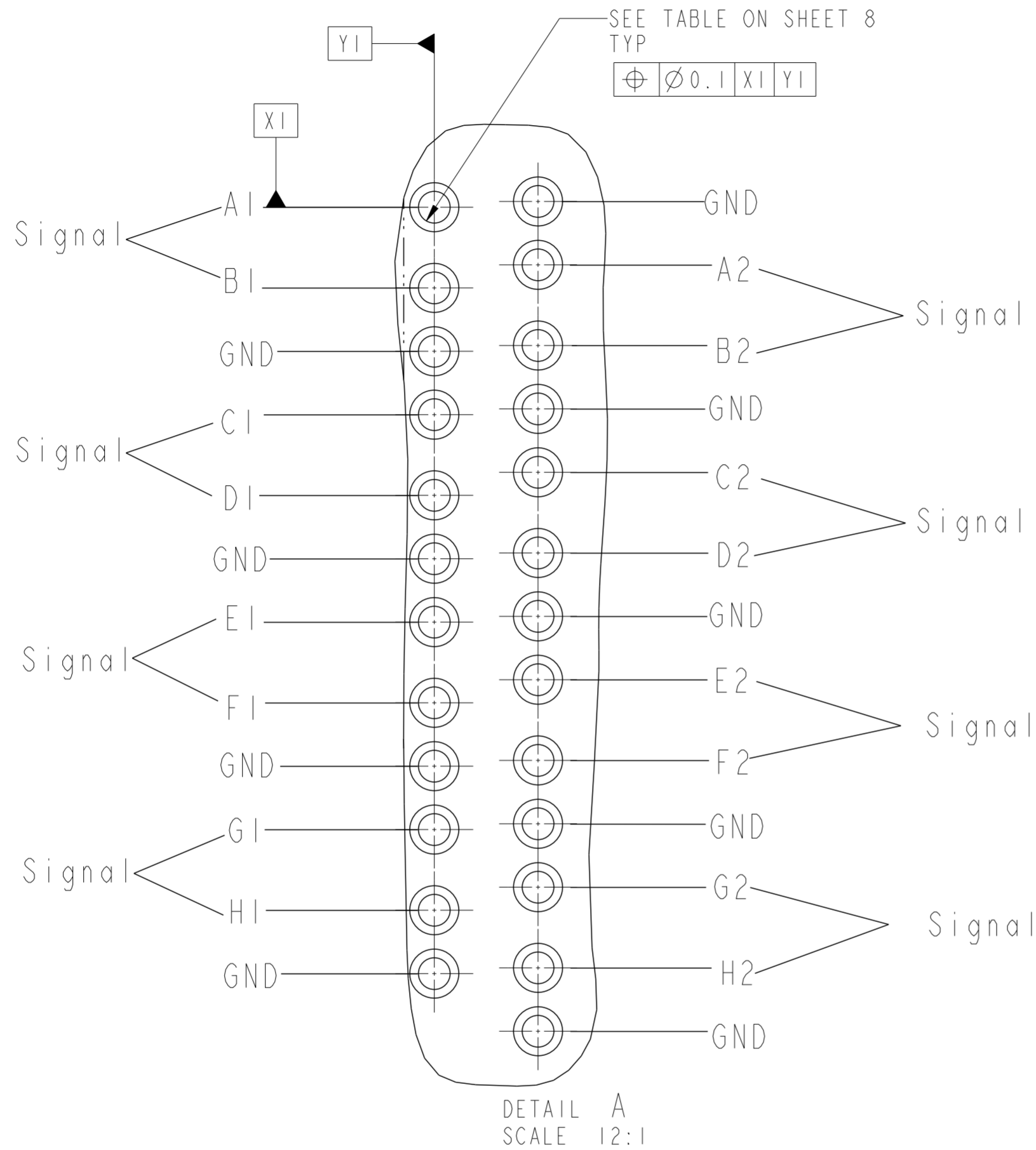

TABLE 3		
	COMPLIANT PIN DRILL $\varnothing 0.55 [0.0217"]$	COMPLIANT PIN DRILL $\varnothing 0.45 [0.0177"]$
PTH	$\varnothing 0.45 \pm 0.05$	$\varnothing 0.36 \pm 0.05$
DRILL	$\varnothing 0.55 [0.0217"]$	$\varnothing 0.45 [0.0177"]$
PAD	$\varnothing 0.85$	$\varnothing 0.75$

NOTES:

- CONNECTOR MATERIALS
SHROUD : HIGH-TEMP POLYMER, COLOR : BLACK, UL94V-0
CONTACTS : HIGH PERFORMANCE COPPER ALLOY
- PRODUCT SPECIFICATION : GS-12-0936
- APPLICATION SPECIFICATION : GS-20-0348
- PRODUCT MARKING :
PART NUMBER (10120128-X0C-XXXLF)
"FCI" AND DATE CODE (FCI P#####)
- NOTCH DESIGNATES "ROW A" SIDE OF CONNECTOR. NOTCH FEATURE ON OPPOSITE FOR PRODUCT MARKING.
- PLATING THICKNESS OF SIGNAL & GROUND CONTACT ARE DETERMINED BY PLATING CODE, REFER TO P/N TREE ON SHEET 1.
- PACKAGING MEETS GS-14-920 LEAD-FREE LABELING SPECIFICATION.
- GUIDE-PIN STYLE DESIGNATION ONLY APPLIES TO MODULE VERSIONS THAT REQUIRE GUIDE-PIN HARDWARE. FOR ALL NON-GUIDE-PIN VERSIONS, THE DEFAULT DASH-NUMBER DIGIT IN THAT LOCATION IS STILL '0'.
- SEE APPLICATION SPECIFICATION FOR ROUTING GUIDELINES, ADDITIONAL PTH GUIDELINES, MATED DIMENSIONS, GUIDE PIN SELECTION, ETC.
- A $\triangle C$ SYMBOL WILL BE NEXT TO ANY DIMENSION, VIEW OR NOTE THAT HAS BEEN MODIFIED WITH THE CURRENT DRAWING REVISION.
- OPTIONAL HOLE LOCATION FOR GROUNDED PIN OR ADDITIONAL GUIDE-PIN SUPPORT. SEE TABLE 1 SHEET 1 FOR ADDITIONAL DETAILS.
- SCREW IS OPTIONAL AND ENGAGES WITH BOTTOM OF GUIDE PIN FROM BENEATH THE PCB FOR ADDITIONAL GUIDE-PIN SUPPORT.

spec ref	-	dr	Yong-Keat Lim	2012/03/01	projection	mm	size	A2	scale	2:1
tolerance std	ISO 406 ISO 1101	eng	Sandar Soe	2016/03/08		mm	ecn no	ELX-S-17624-1	rel level	Released
TOLERANCES UNLESS OTHERWISE SPECIFIED		chr	-	appr						
surface	ISO 1302	linear	0.X	± 0.3			part no	10120128	rev	C
			0.XX	± 0.10	MODULE ASSEMBLY, XCEDE HD Vertical Header, 4 Pair 6 Column		cat. no.	-	Product - Customer Drw	sheet 8 of 8
		angular	0°	$\pm 2^\circ$	www.fci.com					