

General Description

The HXT8212 VCSEL driver array is a key component for compact, robust, low-power optical transmitter modules. In conjunction with the VCSEL array, the chip handles the complete digital-to-optical conversion, including CML input, laser driver, drive control, and supervision. Standard silicon technology and a small number of additional components allow for cost-effective and compact assemblies.

Applications

- 250G Ethernet SR10
- InfiniBand 300G EDR transceivers
- InfiniBand 300G EDR active cables
- Proprietary multi-channel optical modules

Features

- Low power consumption of 113mW per channel while delivering 5mA average and 5mA modulation current
- Compatible with common cathode and isolated VCSEL arrays
- 2-wire interface control and symmetric pad design maximize module design flexibility
- Up to 10 mA average and 10 mA modulation current
- QSFP MSA compliant

Ordering Information

Part	Temp Range	Pin-Package
HXT8212-DNT	0°C to +85°C	Bare Die* 1975 x 3600µm
HXT8212-EVB	Room Temp	Evaluation Board

* Die Design Size; Actual die size may be slightly larger

For price, delivery schedules, and to place orders, please contact IDT: www.IDT.com/go/sales

Device Diagram

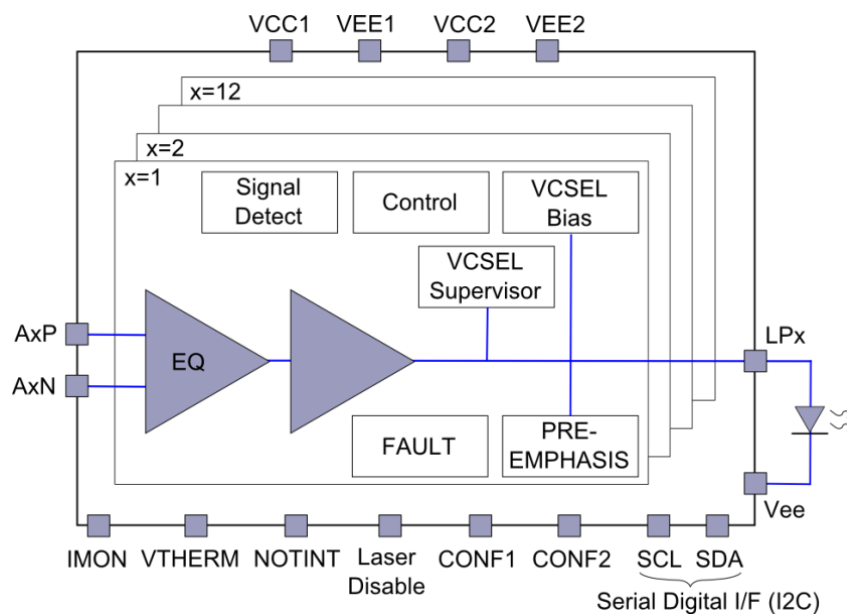

Figure 1: Device diagram



Corporate Headquarters
6024 Silver Creek Valley Road
San Jose, CA 95138
www.IDT.com

Sales
1-800-345-7015 or
408-284-8200
Fax: 408-284-2775
www.IDT.com/go/sales

Tech Support
www.IDT.com/go/support

DISCLAIMER Integrated Device Technology, Inc. (IDT) and its affiliated companies (herein referred to as "IDT") reserve the right to modify the products and/or specifications described herein at any time, without notice, at IDT's sole discretion. Performance specifications and operating parameters of the described products are determined in an independent state and are not guaranteed to perform the same way when installed in customer products. The information contained herein is provided without representation or warranty of any kind, whether express or implied, including, but not limited to, the suitability of IDT's products for any particular purpose, an implied warranty of merchantability, or non-infringement of the intellectual property rights of others. This document is presented only as a guide and does not convey any license under intellectual property rights of IDT or any third parties.

IDT's products are not intended for use in applications involving extreme environmental conditions or in life support systems or similar devices where the failure or malfunction of an IDT product can be reasonably expected to significantly affect the health or safety of users. Anyone using an IDT product in such a manner does so at their own risk, absent an express, written agreement by IDT.

Integrated Device Technology, IDT and the IDT logo are trademarks or registered trademarks of IDT and its subsidiaries in the United States and other countries. Other trademarks used herein are the property of IDT or their respective third party owners. For datasheet type definitions and a glossary of common terms, visit www.idt.com/go/glossary. All contents of this document are copyright of Integrated Device Technology, Inc. All rights reserved.