

**Features**

- Lead Free Finish/RoHS Compliant(Note 1) ("P" Suffix Designates Compliant. See Ordering Information)
- Halogen Free Available Upon Request By Adding Suffix "-HF"
- High Frequency Operation
- High Surge Forward Current Capability
- Epoxy Meets UL 94 V-0 Flammability Rating
- Planar Structure Die and Soft Recovery Characteristics

**Maximum Ratings**

- Operating Junction Temperature Range: -55°C to +150°C
- Storage Temperature Range: -55°C to +150°C
- Thermal Resistance: 1°C/W Junction to Case

MCC Part Number	Device Marking	Maximum Recurrent Peak Reverse Voltage	Maximum RMS Voltage	Maximum DC Blocking Voltage
MUR3060BS	MUR3060BS	600V	420V	600V

**Electrical Characteristics @ 25°C Unless Otherwise Specified**

Average Rectified Forward Current	$I_{F(AV)}$	30A	$T_C=100^\circ\text{C}$	
Peak Forward Surge Current	$I_{FSM}$	300A	8.3ms, Half Sine	
Instantaneous Forward Voltage	$V_F$	1.50V(Typ.) 1.80V(Max.) 1.60V(Max.)	$I_{FM}=30A; T_J=25^\circ\text{C}$ $I_{FM}=30A; T_J=25^\circ\text{C}$ $I_{FM}=30A; T_J=125^\circ\text{C}$	
Reverse Current At Rated DC Blocking Voltage	$I_R$	5 $\mu\text{A}$ (Max.) 200 $\mu\text{A}$ (Max.)	$T_J=25^\circ\text{C}$ $T_J=125^\circ\text{C}$	
Current Squared Time	$I^2t$	373A <sup>2</sup> s	1ms $\leq t \leq$ 8.3ms, $T_J=25^\circ\text{C}$	
Reverse Recovery Time	$t_{rr}$	35ns(Typ.) 45ns(Max.)	$I_F=0.5A; I_R=1.0A;$ $I_{RR}=0.25A$	
		75ns(Typ.) 125ns(Typ.)	$T_J=25^\circ\text{C}$ $T_J=125^\circ\text{C}$	
Peak recovery current	$I_{RRM}$	4.9A(Typ.) 12.8A(Typ.)	$T_J=25^\circ\text{C}$ $T_J=125^\circ\text{C}$	
Reverse recovery charge	$Q_{rr}$	180nC(Typ.) 780nC(Typ.)	$T_J=25^\circ\text{C}$ $T_J=125^\circ\text{C}$	

$I_F=30A$   
 $di_F/dt=-200A/\mu s$   
 $V_R=400V$

Note:1. High Temperature Solder Exemptions Applied, See EU Directive Annex 7a.

**Internal Structure**



**30 Amp  
Ultra Fast  
Recovery Rectifier  
600 Volts**

**TO-247AD**

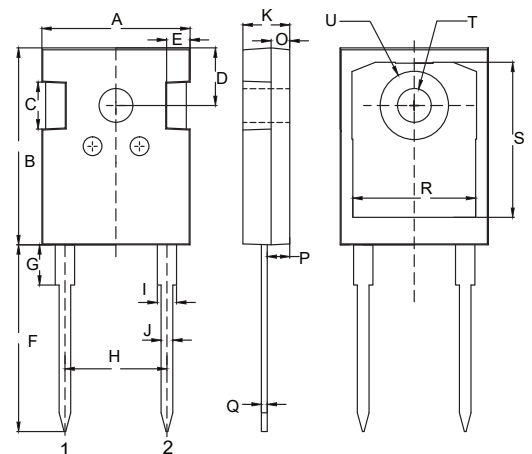

DIM	INCHES		MM		NOTE
	MIN	MAX	MIN	MAX	
A	0.602	0.642	15.30	16.30	
B	0.799	0.839	20.30	21.30	
C	0.189	0.205	4.80	5.20	
D	0.242		6.15		BSC.
E	0.091	0.106	2.30	2.70	
F	0.768	0.807	19.50	20.50	
G	0.189		4.80		
H	0.428		10.88		BSC.
I	0.075	0.087	1.91	2.21	
J	0.044	0.054	1.11	1.36	
K	0.189	0.205	4.80	5.20	
O	0.073	0.085	1.85	2.15	
P	0.087	0.103	2.21	2.61	
Q	0.020	0.030	0.51	0.75	
R	0.512	0.535	13.00	13.60	
S	0.640	0.663	16.25	16.85	
T	0.134	0.150	3.40	3.80	$\Phi$
U	0.287		7.30		$\Phi$

**Curve Characteristics**

Fig. 1 - Forward Current Derating Curve

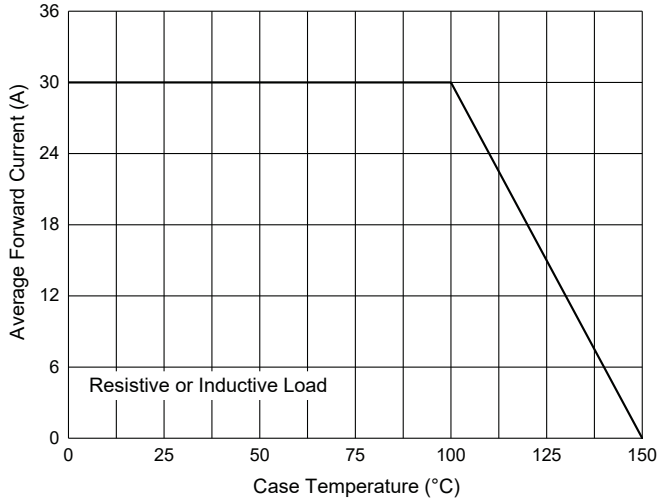

Fig. 2 - Maximum Non-Repetitive Peak Forward Surge Current

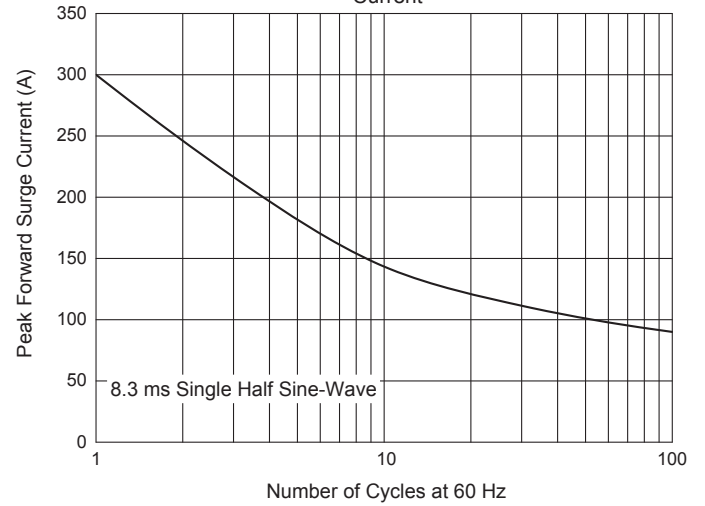

Fig. 3 - Typical Instantaneous Forward Characteristics

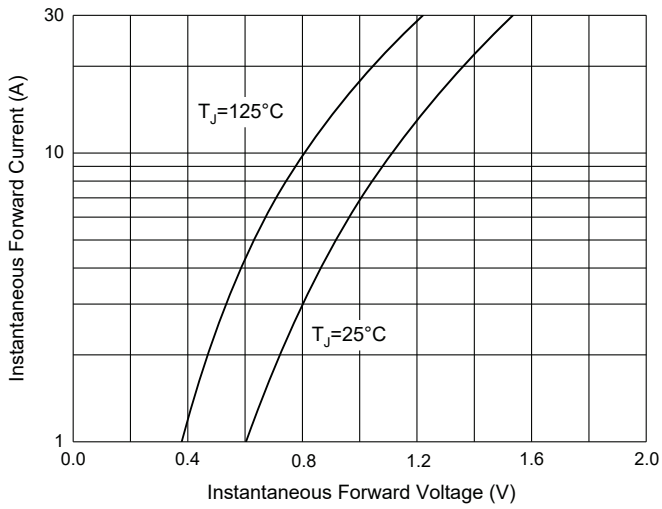
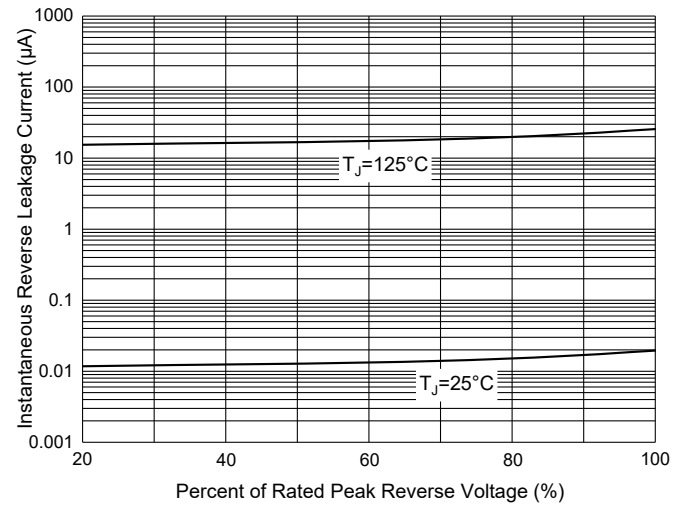

Fig. 4 - Typical Reverse Leakage Characteristics



## Ordering Information

Device	Packing
Part Number-BP	Bulk:30pcs/Tube,360pcs/Box,1.8Kpcs/Carton

Note : Adding "-HF" Suffix For Halogen Free, eg. Part Number-BP-HF

### \*\*\*IMPORTANT NOTICE\*\*\*

**Micro Commercial Components Corp.** reserves the right to make changes without further notice to any product herein to make corrections, modifications , enhancements , improvements , or other changes . **Micro Commercial Components Corp.** . does not assume any liability arising out of the application or use of any product described herein; neither does it convey any license under its patent rights ,nor the rights of others . The user of products in such applications shall assume all risks of such use and will agree to hold **Micro Commercial Components Corp.** . and all the companies whose products are represented on our website, harmless against all damages. **Micro Commercial Components Corp.** products are sold subject to the general terms and conditions of commercial sale, as published at <https://www.mccsemi.com/Home/TermsAndConditions>.

### \*\*\*LIFE SUPPORT\*\*\*

MCC's products are not authorized for use as critical components in life support devices or systems without the express written approval of Micro Commercial Components Corporation.

### \*\*\*CUSTOMER AWARENESS\*\*\*

Counterfeiting of semiconductor parts is a growing problem in the industry. Micro Commercial Components (MCC) is taking strong measures to protect ourselves and our customers from the proliferation of counterfeit parts. MCC strongly encourages customers to purchase MCC parts either directly from MCC or from Authorized MCC Distributors who are listed by country on our web page cited below. Products customers buy either from MCC directly or from Authorized MCC Distributors are genuine parts, have full traceability, meet MCC's quality standards for handling and storage. **MCC will not provide any warranty coverage or other assistance for parts bought from Unauthorized Sources.** MCC is committed to combat this global problem and encourage our customers to do their part in stopping this practice by buying direct or from authorized distributors.