

THIS DRAWING IS UNPUBLISHED. RELEASED FOR PUBLICATION
 © COPYRIGHT - By - ALL RIGHTS RESERVED.

LOC	DIST	REVISIONS			
P	LTR	DESCRIPTION	DATE	DWN	APVD
AF	50	R	REVISED PER ECR-13-004343	30JUL13	KH KR

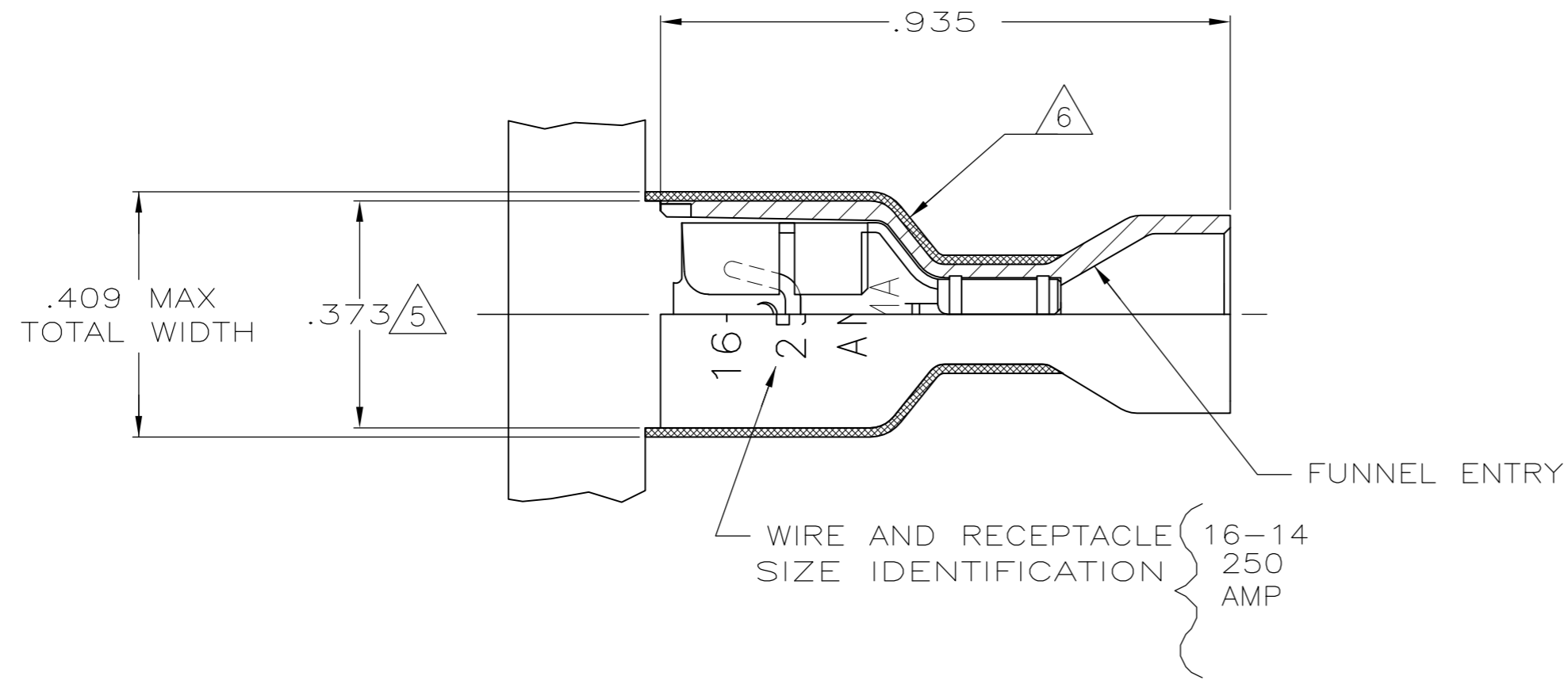

- 1 MATES WITH .032±.001x.250 TAB
- 2 WIRE STRIP LENGTH .281
- 3 INSULATION SIZE .260 MAX DIA
- 4 CONTINUOUS STRIP ON REELS
- 5 DIMENSION DOES NOT INCLUDE TRIM BURR
- 6 .015 MAX CARRIER TRIM BURR PER SIDE IS ALLOWABLE IN THE SHADED AREA
- 7 PRELIMINARY - NOT FOR PRODUCTION

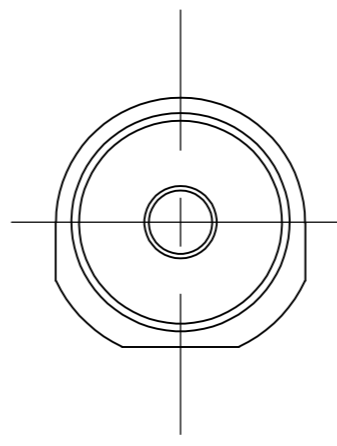
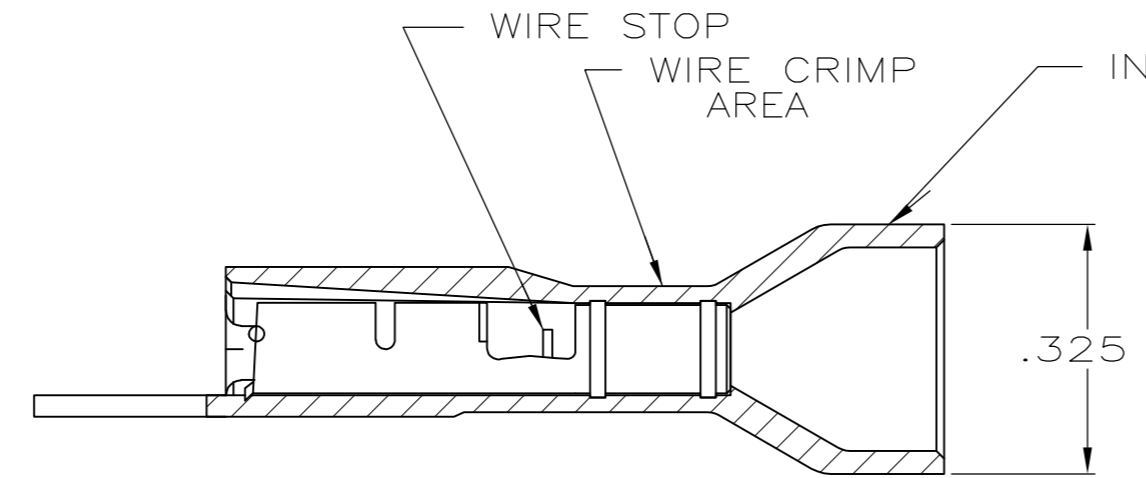
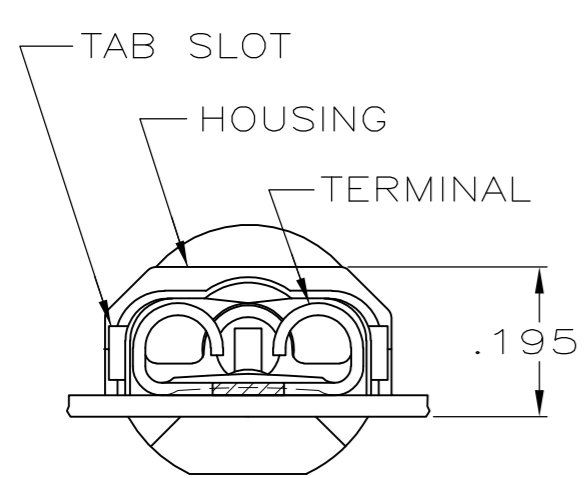

STANDARD	HOUSING: NYLON, COLOR - BLACK RECEPTACLE: BRASS, TIN	9-520140-2
BULK	HOUSING: NYLON, COLOR - BLUE TRANSLUCENT RECEPTACLE: BRASS, TIN	5-520140-2
STANDARD	HOUSING: NYLON, COLOR - BLUE TRANSLUCENT RECEPTACLE: #3 HARD PH BRONZE, TIN	3-520140-4
STANDARD	HOUSING: NYLON, COLOR - BLUE TRANSLUCENT RECEPTACLE: BRASS, TIN	3-520140-2
PACKAGING	MATERIAL & FINISH	PART NO.

THIS DRAWING IS A CONTROLLED DOCUMENT.		DWN	JR RUTH	21NOV00	TE TE Connectivity
DIMENSIONS: INCHES		CHK	MS FEHER	21NOV00	
TOLERANCES UNLESS OTHERWISE SPECIFIED:		APVD	J HUMMEL	21NOV00	
0 PLC ± - 1 PLC ± - 2 PLC ± - 3 PLC ± .015 4 PLC ± - ANGLES ± -		PRODUCT SPEC	108-2043	NAME	
MATERIAL	SEE TABLE	FINISH	SEE TABLE	WEIGHT	-
CUSTOMER DRAWING		SCALE	4:1	SHEET	1 OF 1
		REV	R		

520140