

FEATURES

44 V supply maximum ratings
V_{SS} to V_{DD} analog signal range
Low on resistance: <35 Ω
Ultralow power dissipation: < 35 μW
Fast transition time: 160 ns maximum
Break-before-make switching action
Plug-in replacement for DG419

APPLICATIONS

Precision test equipment
Precision instrumentation
Battery-powered systems
Sample hold systems

GENERAL DESCRIPTION

The ADG419 is a monolithic CMOS SPDT switch. This switch is designed on an enhanced LC²MOS process that provides low power dissipation yet gives high switching speed, low on resistance, and low leakage currents.

The on resistance profile of the ADG419 is very flat over the full analog input range, ensuring excellent linearity and low distortion. The part also exhibits high switching speed and high signal bandwidth. CMOS construction ensures ultralow power dissipation, making the parts ideally suited for portable and battery-powered instruments.

Each switch of the ADG419 conducts equally well in both directions when on and has an input signal range that extends to the supplies. In the off condition, signal levels up to the supplies are blocked. The ADG419 exhibits break-before-make switching action.

FUNCTIONAL BLOCK DIAGRAM

Figure 1.

PRODUCT HIGHLIGHTS

1. Extended Signal Range.
The ADG419 is fabricated on an enhanced LC²MOS process, giving an increased signal range that extends to the supply rails.
2. Ultralow Power Dissipation.
3. Low R_{ON}.
4. Single-Supply Operation.
For applications where the analog signal is unipolar, the ADG419 can be operated from a single rail power supply. The part is fully specified with a single 12 V power supply and remains functional with single supplies as low as 5 V.

Rev. B

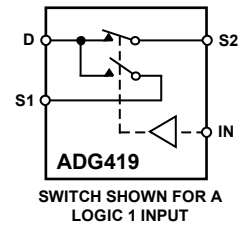
Information furnished by Analog Devices is believed to be accurate and reliable. However, no responsibility is assumed by Analog Devices for its use, nor for any infringements of patents or other rights of third parties that may result from its use. Specifications subject to change without notice. No license is granted by implication or otherwise under any patent or patent rights of Analog Devices. Trademarks and registered trademarks are the property of their respective owners.

TABLE OF CONTENTS

Features	1	Absolute Maximum Ratings	5
Applications.....	1	ESD Caution.....	5
Functional Block Diagram	1	Pin Configuration and Function Descriptions.....	6
General Description	1	Typical Performance Characteristics	7
Product Highlights	1	Test Circuits.....	9
Revision History	2	Terminology	11
Specifications.....	3	Outline Dimensions	12
Dual Supply	3	Ordering Guide	13
Single Supply	4		

REVISION HISTORY

8/09—Rev. B to Rev. C

Updated Format.....	Universal
Changes to Table 1.....	3
Changes to Table 2.....	4
Updated Outline Dimensions	12
Changes to Ordering Guide	13

SPECIFICATIONS

DUAL SUPPLY

$V_{DD} = 15\text{ V} \pm 10\%$, $V_{SS} = -15\text{ V} \pm 10\%$, $V_L = 5\text{ V} \pm 10\%$, $GND = 0\text{ V}$, unless otherwise noted.

Table 1.

Parameter ¹	B Version			T Version		Unit	Test Conditions/Comments
	+25°C	-40°C to +85°C	-40°C to +125°C	+25°C	-55°C to +125°C		
ANALOG SWITCH							
Analog Signal Range			V_{SS} to V_{DD}		V_{SS} to V_{DD}		
R_{ON}	25			25		Ω typ	$V_D = \pm 12.5\text{ V}$, $I_S = -10\text{ mA}$
	35	45	45	35	45	Ω max	$V_{DD} = +13.5\text{ V}$, $V_{SS} = -13.5\text{ V}$
LEAKAGE CURRENTS							
Source Off Leakage, I_S (Off)	± 0.1			± 0.1		nA typ	$V_{DD} = +16.5\text{ V}$, $V_{SS} = -16.5\text{ V}$
Drain Off Leakage, I_D (Off)	± 0.25	± 5	± 15	± 0.25	± 15	nA max	$V_D = \pm 15.5\text{ V}$, $V_S = \mp 15.5\text{ V}$; see Figure 12
	± 0.1			± 0.1		nA typ	$V_D = \pm 15.5\text{ V}$, $V_S = \mp 15.5\text{ V}$; see Figure 12
Channel On Leakage, I_D , I_S (On)	± 0.75	± 5	± 30	± 0.75	± 30	nA max	$V_S = V_D = \pm 15.5\text{ V}$; see Figure 13
	± 0.4			± 0.4		nA typ	
	± 0.75	± 5	± 30	± 0.75	± 30	nA max	
DIGITAL INPUTS							
Input High Voltage, V_{INH}		2.4	2.4		2.4	V min	
Input Low Voltage, V_{INL}		0.8	0.8		0.8	V max	
Input Current							
I_{INL} or I_{INH}		± 0.005	± 0.005		± 0.005	μA typ	$V_{IN} = V_{INL}$ or V_{INH}
		± 0.5	± 0.5		± 0.5	μA max	
DYNAMIC CHARACTERISTICS ²							
$t_{TRANSITION}$	160	200	200	145	200	ns max	$R_L = 300\ \Omega$, $C_L = 35\text{ pF}$; $V_{S1} = \pm 10\text{ V}$, $V_{S2} = \mp 10\text{ V}$; see Figure 14
Break-Before-Make Time Delay, t_D	30			30		ns typ	$R_L = 300\ \Omega$, $C_L = 35\text{ pF}$; $V_{S1} = V_{S2} = \pm 10\text{ V}$; see Figure 15
Off Isolation	5			5		ns min	
Channel-to-Channel Crosstalk	80			80		dB typ	$R_L = 50\ \Omega$, $f = 1\text{ MHz}$; see Figure 16
C_S (Off)	90			70		dB typ	$R_L = 50\ \Omega$, $f = 1\text{ MHz}$; see Figure 17
C_D , C_S (On)	6			6		pF typ	$f = 1\text{ MHz}$
	55			55		pF typ	$f = 1\text{ MHz}$
POWER REQUIREMENTS							
I_{DD}	0.0001			0.0001		μA typ	$V_{DD} = +16.5\text{ V}$, $V_{SS} = -16.5\text{ V}$
	1	2.5	2.5	1	2.5	μA max	$V_{IN} = 0\text{ V}$ or 5 V
I_{SS}	0.0001			0.0001		μA typ	
	1	2.5	2.5	1	2.5	μA max	
I_L	0.0001			0.0001		μA typ	$V_L = 5.5\text{ V}$
	1	2.5	2.5	1	2.5	μA max	

¹ Temperature ranges are as follows: B Version: -40°C to $+125^\circ\text{C}$; T Version: -55°C to $+125^\circ\text{C}$.

² Guaranteed by design, not subject to production test.

ADG419

SINGLE SUPPLY

$V_{DD} = 12\text{ V} \pm 10\%$, $V_{SS} = 0\text{ V}$, $V_L = 5\text{ V} \pm 10\%$, $GND = 0\text{ V}$, unless otherwise noted.

Table 2.

Parameter ¹	B Version			T Version		Unit	Test Conditions/Comments
	+25°C	-40°C to +85°C	-40°C to +125°C	+25°C	-55°C to +125°C		
ANALOG SWITCH							
Analogue Signal Range			0 to V_{DD}		0 to V_{DD}	V	
R_{ON}	40	60	70	40	70	Ω typ Ω max	$V_D = 3\text{ V}, 8.5\text{ V}, I_S = -10\text{ mA}$ $V_{DD} = 10.8\text{ V}$
LEAKAGE CURRENT							
Source OFF Leakage, I_S (Off)	± 0.1			± 0.1		nA typ	$V_{DD} = 13.2\text{ V}$ $V_D = 12.2\text{ V}/1\text{ V}, V_S = 1\text{ V}/12.2\text{ V}$; see Figure 12
Drain OFF Leakage, I_D (Off)	± 0.25 ± 0.1	± 5	± 15	± 0.25 ± 0.1	± 15	nA max nA typ	$V_D = 12.2\text{ V}/1\text{ V}, V_S = 1\text{ V}/12.2\text{ V}$; see Figure 12
Channel ON Leakage, I_D, I_S (On)	± 0.75 ± 0.4 ± 0.75	± 5	± 30	± 0.75 ± 0.4 ± 0.75	± 30	nA max nA typ nA max	$V_S = V_D = 12.2\text{ V}/1\text{ V}$; see Figure 13
DIGITAL INPUTS							
Input High Voltage, V_{INH}		2.4	2.4		2.4	V min	
Input Low Voltage, V_{INL}		0.8	0.8		0.8	V max	
Input Current I_{INL} or I_{INH}		± 0.005 ± 0.5	± 0.005 ± 0.5		± 0.005 ± 0.5	μA typ μA max	$V_{IN} = V_{INL}$ or V_{INH}
DYNAMIC CHARACTERISTICS²							
$t_{TRANSITION}$	180	250	250	170	250	ns max	$R_L = 300\ \Omega, C_L = 35\text{ pF}; V_{S1} = 0\text{ V}/8\text{ V}, V_{S2} = 8\text{ V}/0\text{ V}$; see Figure 14
Break-Before-Make Time Delay, t_D	60			60		ns typ	$R_L = 300\ \Omega, C_L = 35\text{ pF}; V_{S1} = V_{S2} = 8\text{ V}$; see Figure 15
Off Isolation	80			80		dB typ	$R_L = 50\ \Omega, f = 1\text{ MHz}$; see Figure 16
Channel-to-Channel Crosstalk	90			70		dB typ	$R_L = 50\ \Omega, f = 1\text{ MHz}$; see Figure 17
C_S (Off)	13			13		pF typ	$f = 1\text{ MHz}$
C_D, C_S (On)	65			65		pF typ	$f = 1\text{ MHz}$
POWER REQUIREMENTS							
I_{DD}	0.0001			0.0001		μA typ	$V_{DD} = 13.2\text{ V}$ $V_{IN} = 0\text{ V}$ or 5 V
	1	2.5	2.5	1	2.5	μA max	
I_L	0.0001			0.0001		μA typ	$V_L = 5.5\text{ V}$
	1	2.5	2.5	1	2.5	μA max	

¹ Temperature ranges are as follows: B Version: -40°C to $+125^\circ\text{C}$; T Version: -55°C to $+125^\circ\text{C}$.

² Guaranteed by design, not subject to production test.

ABSOLUTE MAXIMUM RATINGS

$T_A = 25^\circ\text{C}$ unless otherwise noted.

Table 3.

Parameter	Rating
V_{DD} to V_{SS}	44 V
V_{DD} to GND	-0.3 V to +25 V
V_{SS} to GND	+0.3 V to -25 V
V_L to GND	-0.3 V to $V_{DD} + 0.3$ V
Analog, Digital Inputs ¹	$V_{SS} - 2$ V to $V_{DD} + 2$ V or 30 mA, whichever occurs first
Continuous Current, S or D	30 mA
Peak Current, S or D (Pulsed at 1 ms, 10% Duty-Cycle Maximum)	100 mA
Operating Temperature Range	
Industrial (B Version)	-40°C to +125°C
Extended (T Version)	-55°C to +125°C
Storage Temperature Range	-65°C to +150°C
Junction Temperature	150°C
CERDIP Package, Power Dissipation	600 mW
θ_{JA} , Thermal Impedance	110°C/W
Lead Temperature, Soldering (10 sec)	300°C
PDIP Package, Power Dissipation	400 mW
θ_{JA} , Thermal Impedance	100°C/W
Lead Temperature, Soldering (10 sec)	260°C
SOIC Package, Power Dissipation	400 mW
θ_{JA} , Thermal Impedance	155°C/W
MSOP Package, Power Dissipation	315 mW
θ_{JA} , Thermal Impedance	205°C/W
Lead Temperature, Soldering	
Vapor Phase (60 sec)	215°C
Infrared (15 sec)	220°C

¹Overvoltages at IN, S or D is clamped by internal diodes. Limit current to the maximum ratings given.

Stresses above those listed under Absolute Maximum Ratings may cause permanent damage to the device. This is a stress rating only; functional operation of the device at these or any other conditions above those indicated in the operational section of this specification is not implied. Exposure to absolute maximum rating conditions for extended periods may affect device reliability.

ESD CAUTION



ESD (electrostatic discharge) sensitive device.

Charged devices and circuit boards can discharge without detection. Although this product features patented or proprietary protection circuitry, damage may occur on devices subjected to high energy ESD. Therefore, proper ESD precautions should be taken to avoid performance degradation or loss of functionality.

ADG419

PIN CONFIGURATION AND FUNCTION DESCRIPTIONS

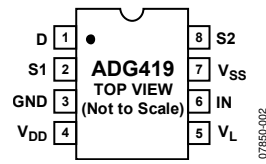

Figure 2. Pin Configuration

Table 4. Pin Function Description

Pin No.	Mnemonic	Description
1	D	Drain terminal. May be an input or an output.
2	S1	Source terminal. May be an input or an output.
3	GND	Ground (0 V) reference.
4	V _{DD}	Most positive power supply potential.
5	V _L	Logic power supply (5 V).
6	IN	Logic control input.
7	V _{SS}	Most negative power supply potential in dual-supply applications. In single-supply applications, it may be connected to GND.
8	S2	Source terminal. May be an input or an output.

Table 5. Truth Table

Logic	Switch 1	Switch 2
0	On	Off
1	Off	On

TYPICAL PERFORMANCE CHARACTERISTICS

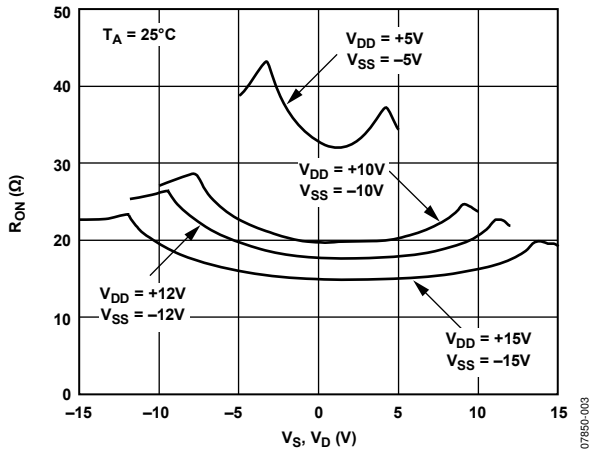

Figure 3. R_{ON} as a Function of V_D (V_S), Dual-Supply Voltage

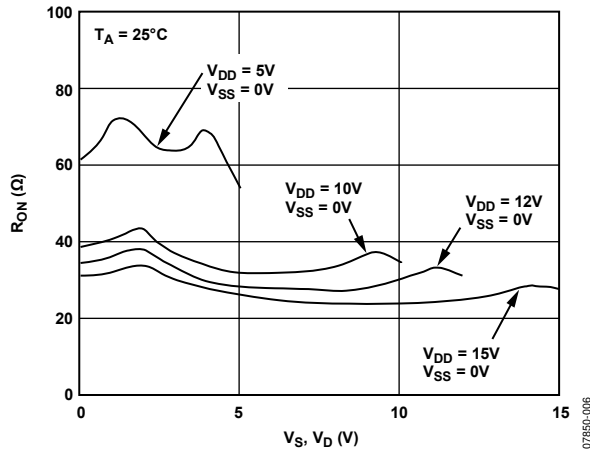

Figure 6. R_{ON} as a Function of V_D (V_S), Single-Supply Voltage

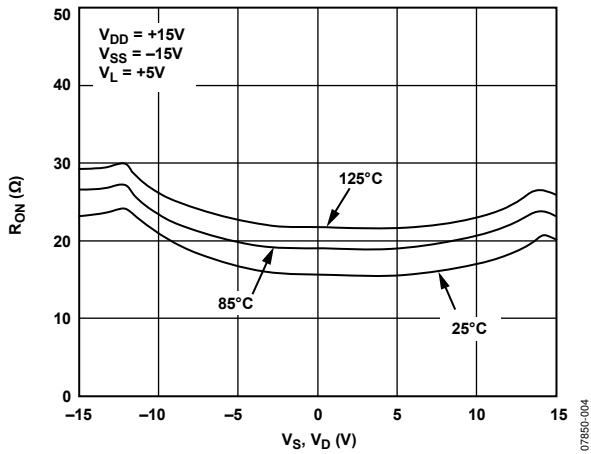

Figure 4. R_{ON} as a Function of V_D (V_S) for Different Temperatures

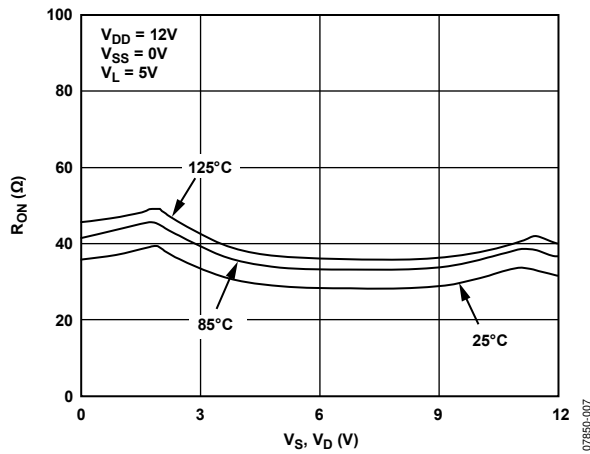

Figure 7. R_{ON} as a Function of V_D (V_S) for Different Temperatures

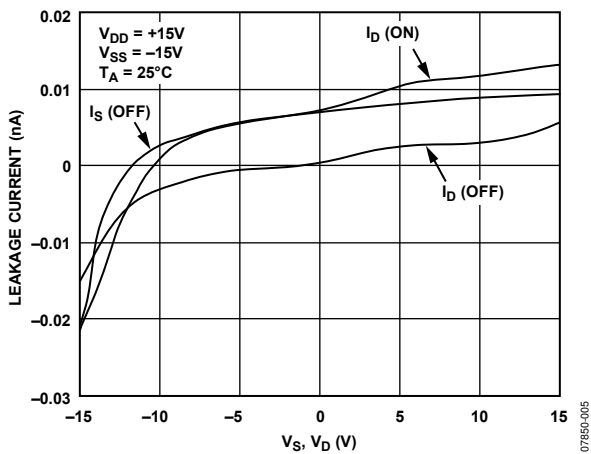

Figure 5. Leakage Currents as a Function of V_S (V_D)

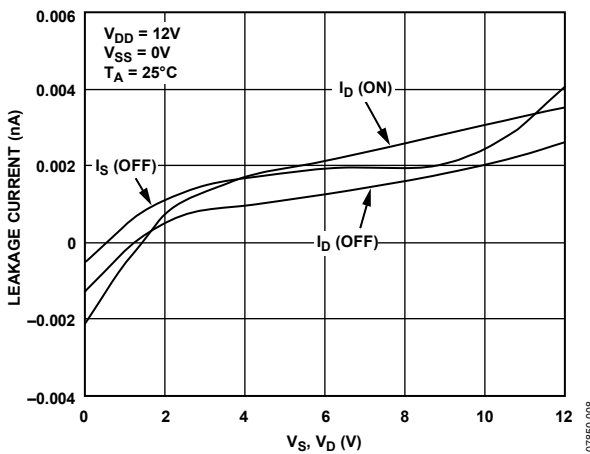

Figure 8. Leakage Currents as a Function of V_S (V_D)

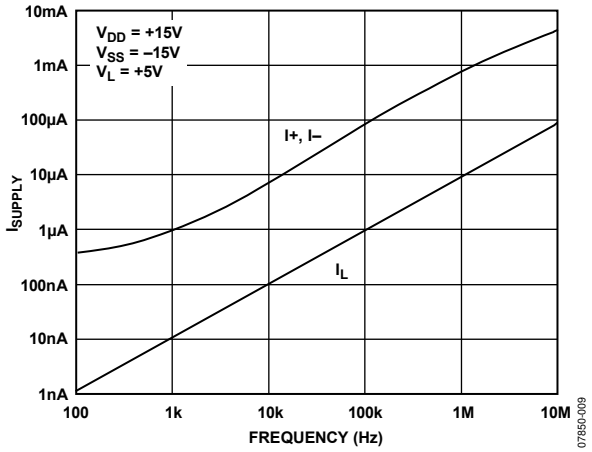

Figure 9. Supply Current (I_{SUPPLY}) vs. Input Switching Frequency

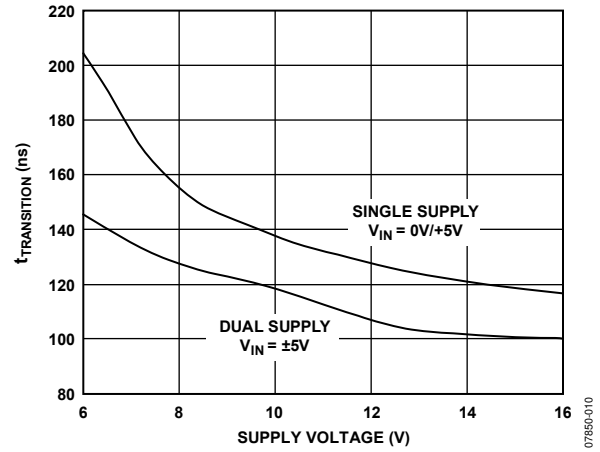

Figure 10. Transition Time ($t_{TRANSITION}$) vs. Power Supply Voltage

TEST CIRCUITS

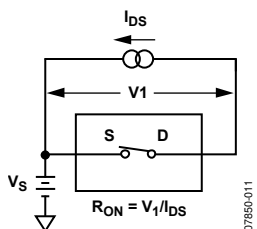

Figure 11. On Resistance

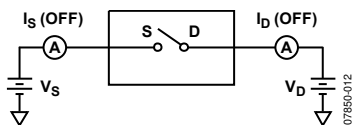

Figure 12. Off Leakage

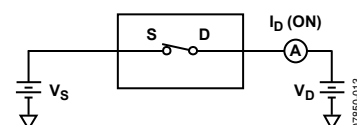

Figure 13. On Leakage

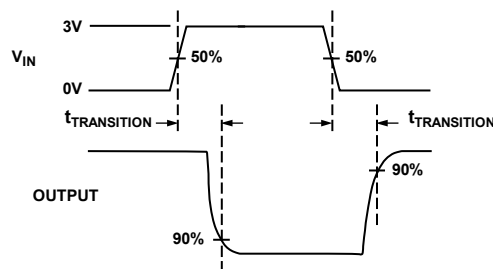
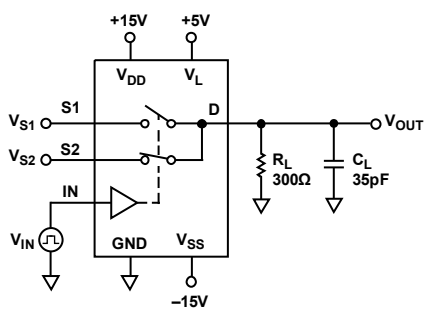

Figure 14. Transition Time, $t_{\text{TRANSITION}}$

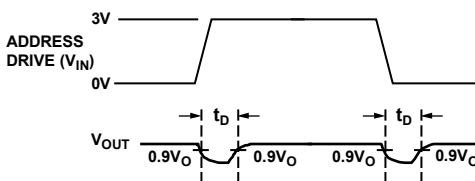
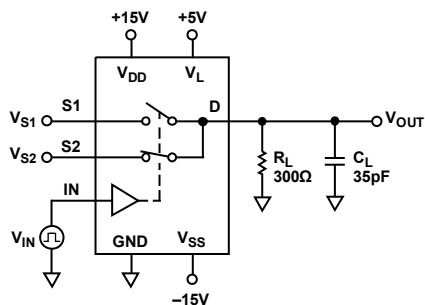

Figure 15. Break-Before-Make Time Delay, t_D

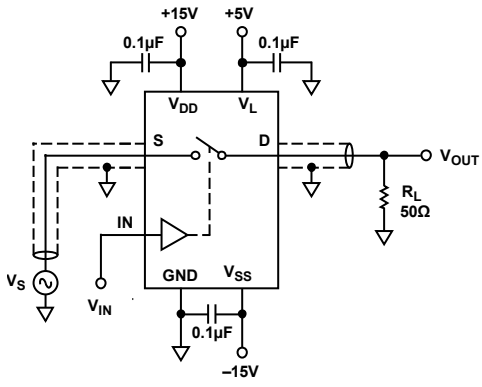
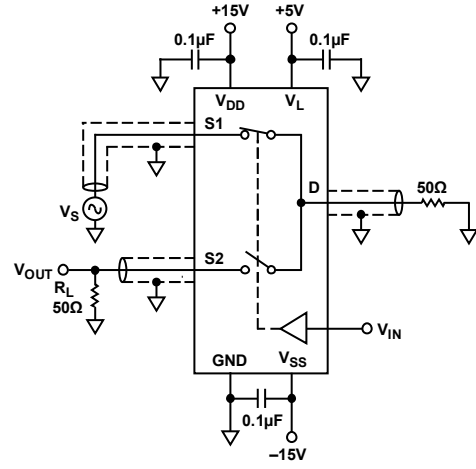

Figure 16. Off Isolation

07850-016



$$\text{CHANNEL-TO-CHANNEL CROSSTALK} = 20 \times \log |V_S/V_{OUT}|$$

Figure 17. Crosstalk

07850-017

TERMINOLOGY

V_{DD}

Most positive power supply potential.

V_{SS}

Most negative power supply potential in dual-supply applications.
In single-supply applications, it may be connected to GND.

V_L

Logic power supply (5 V).

GND

Ground (0 V) reference.

S

Source terminal. May be an input or an output.

D

Drain terminal. May be an input or an output.

IN

Logic control input.

R_{ON}

Ohmic resistance between D and S.

I_S (Off)

Source leakage current with the switch off.

I_D (Off)

Drain leakage current with the switch off.

I_D, I_S (On)

Channel leakage current with the switch on.

V_D (V_S)

Analog voltage on terminals D, S.

C_S (Off)

Off switch source capacitance.

C_D, C_S (On)

On switch capacitance.

t_{TRANSITION}

Delay time between the 50% and 90% points of the digital inputs and the switch on condition when switching from one address state to another.

t_D

Off time or on time measured between the 90% points of both switches when switching from one address state to the other.

V_{INL}

Maximum input voltage for Logic 0.

V_{INH}

Minimum input voltage for Logic 1.

I_{INL} (I_{INH})

Input current of the digital input.

Crosstalk

A measure of unwanted signal that is coupled through from one channel to another as a result of parasitic capacitance.

Off Isolation

A measure of unwanted signal coupling through an off channel.

I_{DD}

Positive supply current.

I_{SS}

Negative supply current.

OUTLINE DIMENSIONS

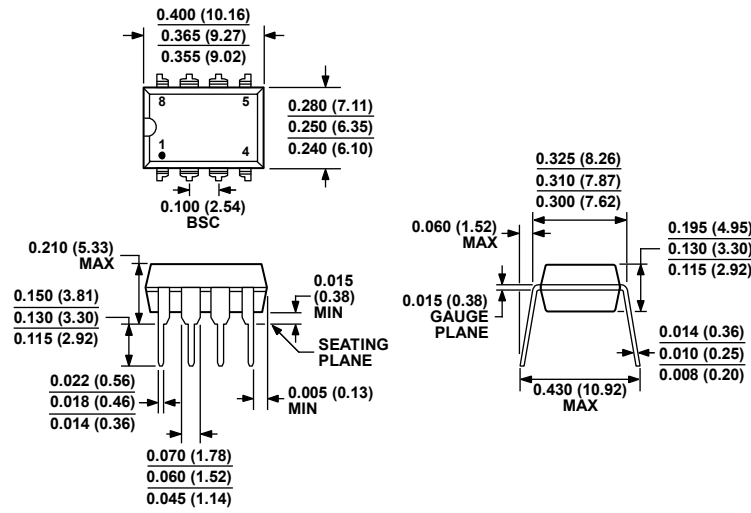

COMPLIANT TO JEDEC STANDARDS MS-001
 CONTROLLING DIMENSIONS ARE IN INCHES; MILLIMETER DIMENSIONS
 (IN PARENTHESES) ARE ROUNDED-OFF INCH EQUIVALENTS FOR
 REFERENCE ONLY AND ARE NOT APPROPRIATE FOR USE IN DESIGN.
 CORNER LEADS MAY BE CONFIGURED AS WHOLE OR HALF LEADS.

Figure 18. 8-Lead Plastic Dual In-Line Package [PDIP]
 Narrow Body
 (N-8)

Dimensions shown in inches and (millimeters)

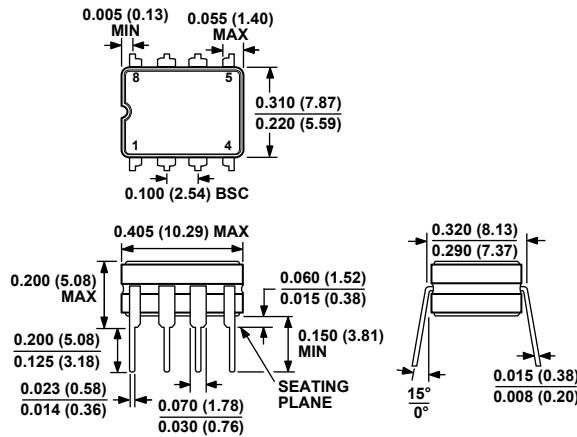

CONTROLLING DIMENSIONS ARE IN INCHES; MILLIMETER DIMENSIONS
 (IN PARENTHESES) ARE ROUNDED-OFF INCH EQUIVALENTS FOR
 REFERENCE ONLY AND ARE NOT APPROPRIATE FOR USE IN DESIGN.

Figure 19. 8-Lead Ceramic Dual In-Line Package [CERDIP]
 (Q-8)

Dimensions shown in inches and (millimeters)

070606-A

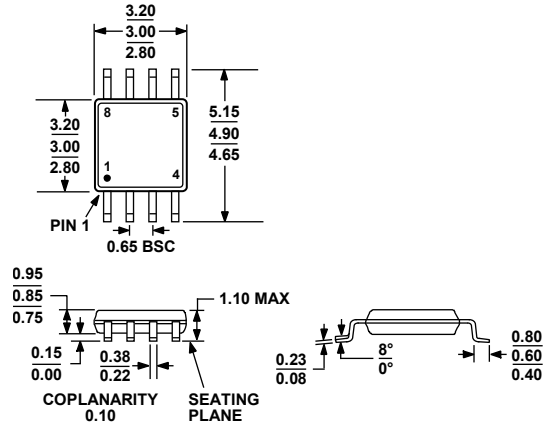

COMPLIANT TO JEDEC STANDARDS MO-187-AA

Figure 20. 8-Lead Mini Small Outline Package [MSOP] (RM-8)

Dimensions shown in millimeters

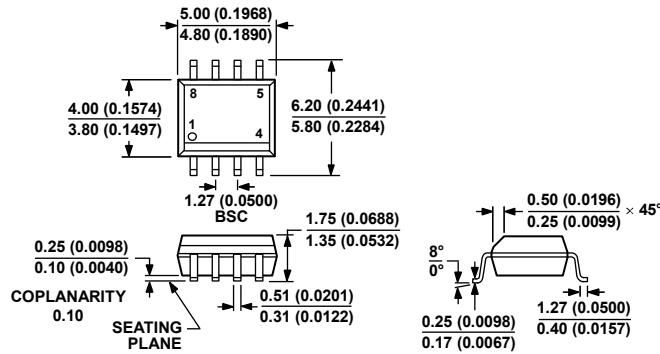

COMPLIANT TO JEDEC STANDARDS MS-012-AA
CONTROLLING DIMENSIONS ARE IN MILLIMETERS; INCH DIMENSIONS (IN PARENTHESES) ARE ROUNDED-OFF MILLIMETER EQUIVALENTS FOR REFERENCE ONLY AND ARE NOT APPROPRIATE FOR USE IN DESIGN.

Figure 21. 8-Lead Standard Small Outline Package [SOIC_N]

Narrow Body (R-8)

Dimensions shown in millimeters and (inches)

012407-A

ORDERING GUIDE

Model	Temperature Range	Package Description	Package Option	Branding
ADG419BN	-40°C to +125°C	8-Lead Plastic Dual In-Line Package [PDIP]	N-8	
ADG419BNZ ¹	-40°C to +125°C	8-Lead Plastic Dual In-Line Package [PDIP]	N-8	
ADG419BR	-40°C to +125°C	8-Lead Standard Small Outline Package [SOIC_N]	R-8	
ADG419BR-REEL	-40°C to +125°C	8-Lead Standard Small Outline Package [SOIC_N]	R-8	
ADG419BR-REEL7	-40°C to +125°C	8-Lead Standard Small Outline Package [SOIC_N]	R-8	
ADG419BRZ ¹	-40°C to +125°C	8-Lead Standard Small Outline Package [SOIC_N]	R-8	
ADG419BRZ-REEL ¹	-40°C to +125°C	8-Lead Standard Small Outline Package [SOIC_N]	R-8	
ADG419BRZ-REEL7 ¹	-40°C to +125°C	8-Lead Standard Small Outline Package [SOIC_N]	R-8	
ADG419BRM	-40°C to +125°C	8-Lead Mini Small Outline Package [MSOP]	RM-8	SBB
ADG419BRM-REEL	-40°C to +125°C	8-Lead Mini Small Outline Package [MSOP]	RM-8	SBB
ADG419BRM-REEL7	-40°C to +125°C	8-Lead Mini Small Outline Package [MSOP]	RM-8	SBB
ADG419BRMZ ¹	-40°C to +125°C	8-Lead Mini Small Outline Package [MSOP]	RM-8	SBB#
ADG419BRMZ-REEL ¹	-40°C to +125°C	8-Lead Mini Small Outline Package [MSOP]	RM-8	SBB#
ADG419BRMZ-REEL7 ¹	-40°C to +125°C	8-Lead Mini Small Outline Package [MSOP]	RM-8	SBB#
ADG419TQ	-55°C to +125°C	8-Lead Ceramic Dual In-Line Package [CERDIP]	Q-8	

¹ Z = RoHS Compliant Part, # denotes that RoHS compliant part is top or bottom marked.

ADG419

NOTES

NOTES

ADG419

NOTES