

FEATURES

- TO-5, 5 Pin Package
- Windowless Package

Electro-Optical Characteristics at 25°C (Per Element)

Parameters	Test Conditions	Min	Typ	Max	Units
Active Area	Per Quadrant		1.25		mm ²
Responsivity	@ 254 nm		0.02		A/W
Dark Current, I _{dr}	V _R = ± 18 V		1	100	nA
Reverse Breakdown Voltage, V _R	I _R = 1 μA	20			Volts
Capacitance, C	V _R = 0 V		100	300	pF
Response Time, t _r	V _R = 0 V		1		μsec
Shunt Resistance	V _f = ± 10 mV	100			MOhms

Thermal Parameters

Storage and Operating Temperature Range	Units
Ambient	-10°C to 40°C
Nitrogen or Vacuum	-20°C to 80°C
Lead Soldering Temperature ¹	260°C

¹ 0.08" from case for 10 seconds.

Typical Photon Responsivity

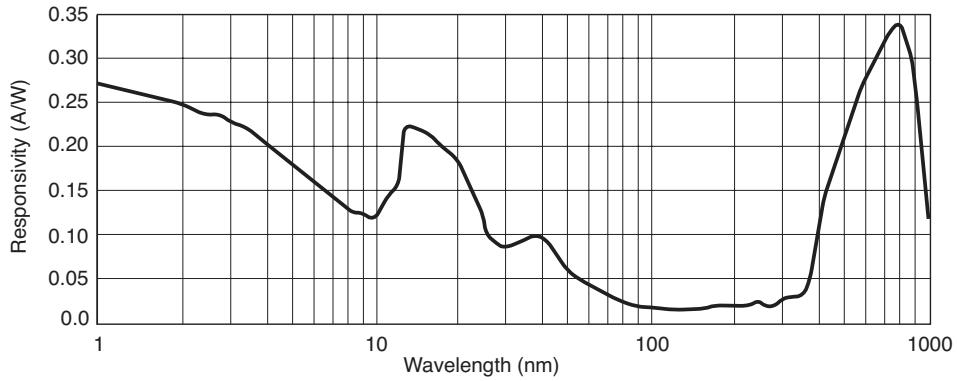

Capacitance vs. Voltage

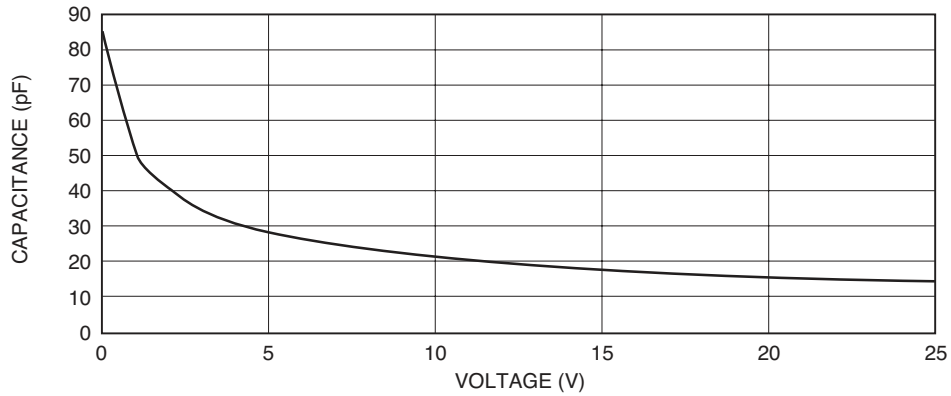

Dark Current vs. Voltage

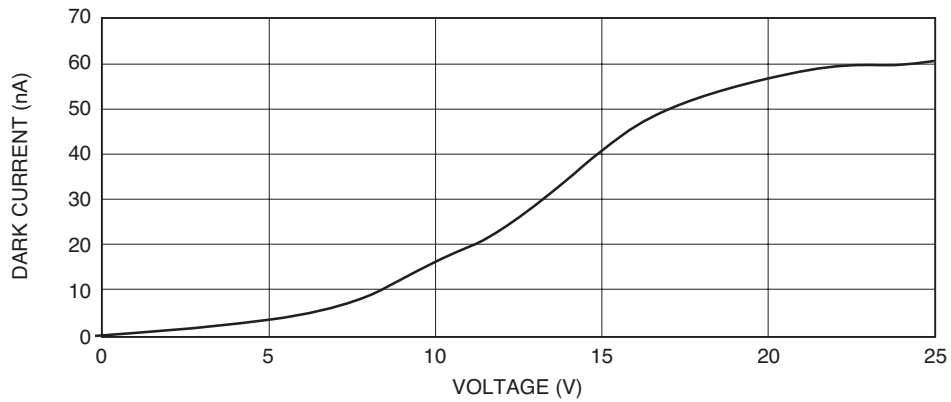

Package Information

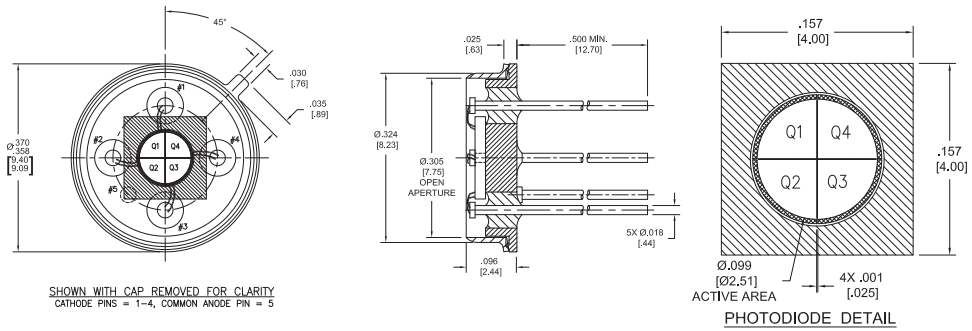

Dimensions are in inches [metric] units.

Specifications are subject to change without prior notice.