

REFERENCE FOR REEL ACCORDING TO FEEDING DIRECTION

GAUGE	REEL OF 5000 FEMALE CTS		REEL OF 10 000 FEMALE CTS		GAUGE	REEL OF 5000 PIN CONTACTS		REEL OF 10 000 PIN CTS	
# 24-28	86566510064	86566510064LF		-	# 24-28	86564510064	86564510064LF		-
# 20-24	86566520064	86566520064LF	86566530064	86566530064LF	# 20-24	86564520064	86564520064LF	86564530064	86564530064LF

\varnothing 450 mm reel of 5000
 \varnothing 600 mm reel of 10 000

SEE DETAIL B

SEE DETAIL A

DETAIL B
SCALE 3.000

DETAIL A
SCALE 3.000

Manufacturer's code

CONTACT DIMENSIONS
SEE SHEET 2/2

CORE RANGE



Copyright FCI.

NOTE: ROHS INFORMATIONS
 The LF products meet European union directives and other country regulations as described in GS-22-008
 Terminations plating spec: 2µm Nickel min + 2µm Sn min
 Packaging spec: see GS-14-920

rev	ecn no	dr	date
F	LS06-196	MPE	27/11/2006
G	LS08-0127	MPE	2008/05/13
H	I09-0152	AMR	2009-07-27
J	I10-0070	AMR	2010-03-09
-	-	-	-
-	-	-	-
-	-	-	-

www.fciconnect.com		surface ISO 1302	- ✓	tolerance std ISO 406 ISO 1101	projection ISO 1101	mm
TOLERANCES UNLESS OTHERWISE SPECIFIED				size A3		Scale 1.000
Dr	-	18/04/03	ANGULAR	0.X	±0.3	ECN 110-0070
Eng	-	-	LINEAR	0.XX	±0.1	Spec ref -
Chr	-	-	0° ±2°	0.XXX	±0.05	
Appr	-	-	Product family			
FCI		CRIMP PIN		dwg no C01-8656-0522		Rev. J
#Wire 24-28 Ø1.02		catalog no		customer		sheet 1 of 2

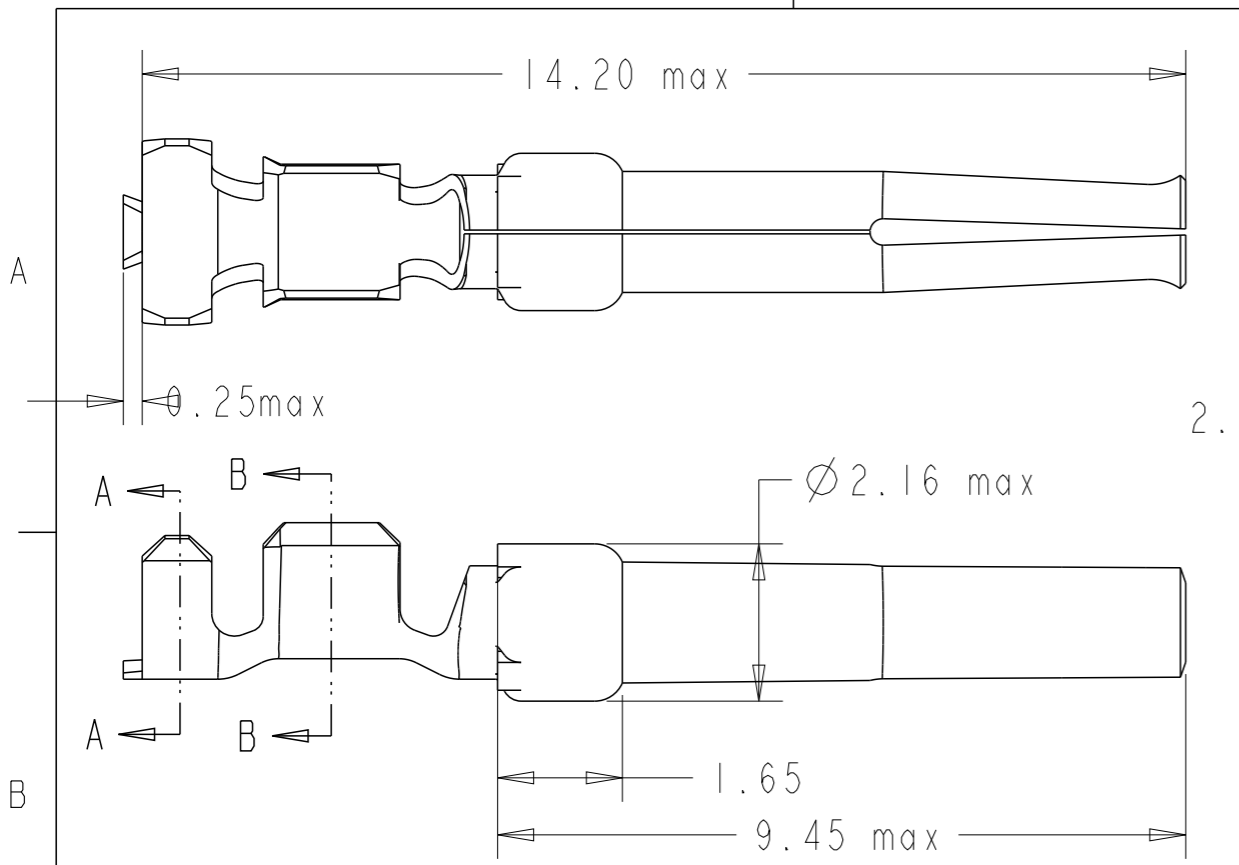

CROSS SECTIONS
FOR CT #20-24

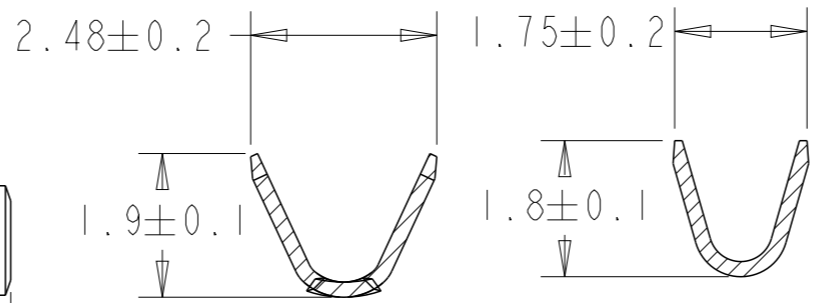

SECTION A-A SECTION B-B

- NOTES:
- 1-Material: Phosphor bronze, thickness 0.20
socket :Phosphor bronze
 - 2-Finish on contact area:
-termination 064.. gold flash
 finish on termination:bright tin over nickel
 - 3-Wire range:20 to 28 AWG(see ref sheet 1/2)
 - 4-Max outer dia of wire insulator:
-1.73 mm for contact #20-24
-1.02 mm for contact #24-28
 - 5-Current carrying capacity per contact:
 5.Amps max when crimped to #20 AWG
 5 Amps max when crimped to #22 AWG
 3 Amps max when crimped to #24 AWG
 2 Amps max when crimped to #26 AWG
 1 Amps max when crimped to #28 AWG
 - 6-After 5 insertions into connector,
 contact retention must be 5 pounds axial load min
 - 7-When contact is crimped to 20 AWG, the insulation
 support crimped height must be 1.78 mm max to ensure
 a proper insertion into housing
 - 6-Packaging:Reel

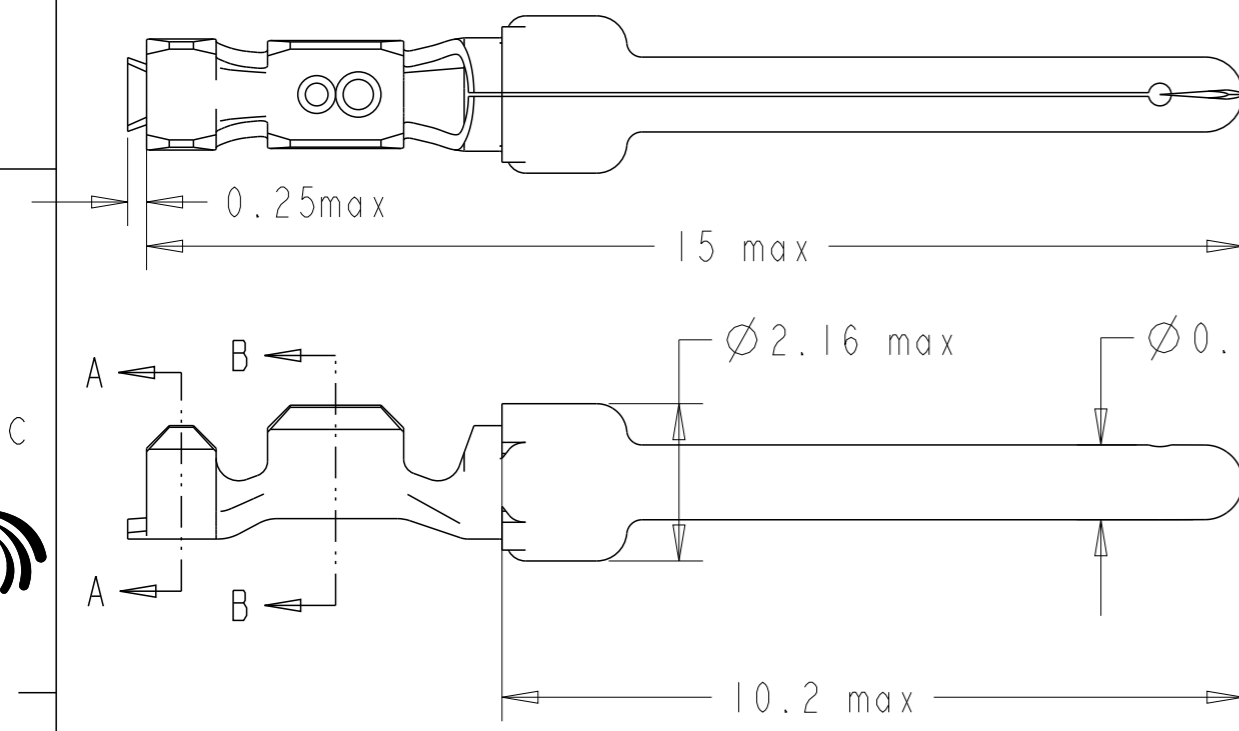

CROSS SECTIONS
FOR CT #24-28

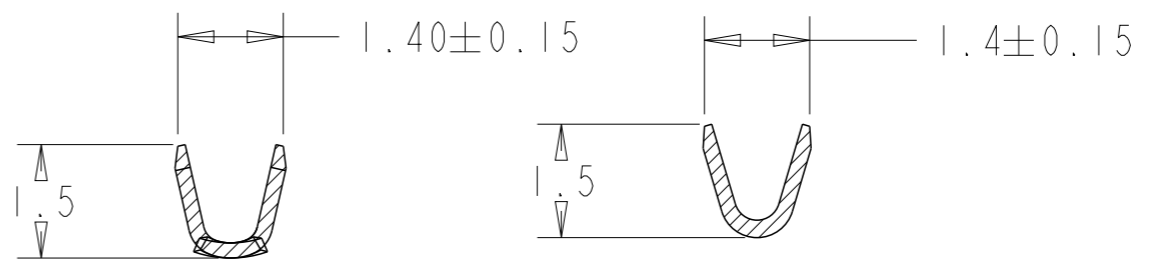

SECTION A-A SECTION B-B



Copyright FCI.

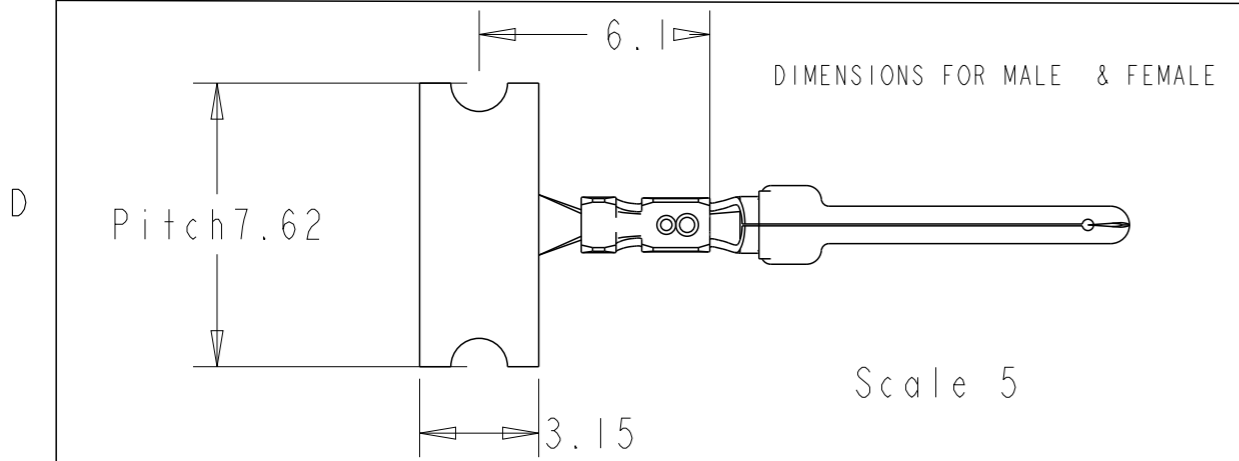

www.fciconnect.com		surface - ✓ ISO 1302	tolerance std ISO 406 ISO 1101	projection mm
TOLERANCES UNLESS OTHERWISE SPECIFIED				
Dr	-	18/04/03	ANGULAR	0.X ±0.3
Eng	-	-	LINEAR	0.XX ±0.1
Chr	-	-	0° ±2°	0.XXX ±0.05
Appr	-	-	Product family	ECN 110-0070
FCI		CRIMP PIN		Rev. J
#Wire 24-28 Ø1.02		catalog no		customer
dwg no		C01-8656-0522		sheet 2 of 2