

# MAXIM

## Programmable Positive Voltage Regulator

ICL7663

### General Description

The Maxim ICL7663 is a high efficiency positive voltage regulator with a quiescent current of less than  $10\mu\text{A}$ . The output voltage is set by two external resistors to any voltage in the 1.3–16V range, with an input voltage range of 1.5–16V. The ICL7663 is well suited for battery powered supplies, featuring low quiescent current, 40mA output current capability, low  $V_{\text{IN}}$  to  $V_{\text{OUT}}$  differential, and a logic input level shutdown control. In addition, the ICL7663 has a negative temperature coefficient output suitable for generating a temperature compensated display drive voltage for multiplexed LCD display systems.

The Maxim ICL7663A is an enhanced version of the ICL7663, with a 1% accurate voltage reference, which eliminates the need for trimming the output voltage in most applications.

The ICL7663B is a reduced input voltage range version limited to a maximum of 10V input.

### Applications

Designed specifically for battery powered systems, the ICL7663 positive voltage regulator excels wherever low quiescent power, wide voltage range operation, medium output current levels, current limiting, and logic-controlled shutdown is desired.

Handheld Instruments                      Pager  
LCD Display Module and                  Remote Data Loggers  
Systems

### Pin Configuration

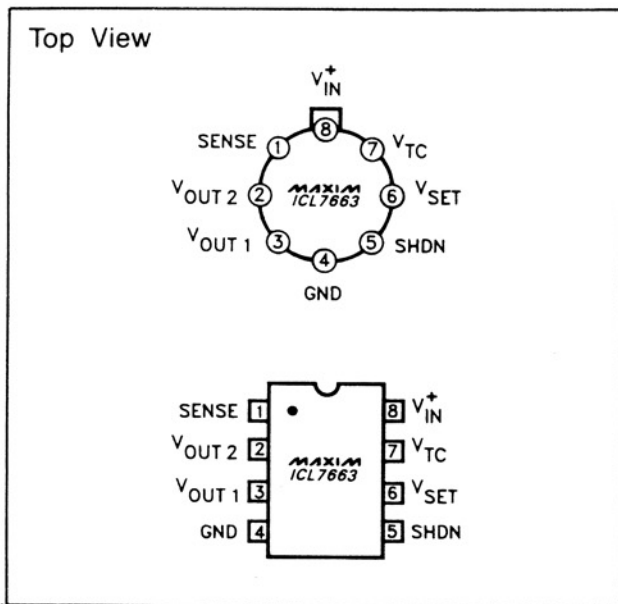

### Features

- ◆ Improved 2nd Source! (See 3rd page for "Maxim Advantage™").
- ◆ 1% Output Voltage Accuracy (ICL7663A)
- ◆ Quiescent Current guaranteed over Temperature
- ◆ Improved Temperature Coefficient of Output Voltage
- ◆ 40mA Output Current, with Current Limiting
- ◆ 1.5V to 16V Operating Range
- ◆ Adjustable Output Voltage
- ◆ Low Input-to-Output Voltage Drop
- ◆ Monolithic, Low Power CMOS Design

### Ordering Information

PART	TEMP. RANGE	PACKAGE
ICL7663C/D	0°C to +70°C	Dice
ICL663CPA	0°C to +70°C	8 Lead Plastic DIP
ICL7663CSA	0°C to +70°C	8 Lead Small Outline
ICL7663IJA	-20°C to +85°C	8 Lead CERDIP
ICL7663ITV	-20°C to +85°C	8 Lead TO-99
ICL7663AC/D	0°C to +70°C	Dice
ICL7663ACPA	0°C to +70°C	8 Lead Plastic DIP
ICL7663ACSA	0°C to +70°C	8 Lead Small Outline
ICL7663AIJA	-20°C to +85°C	8 Lead CERDIP
ICL7663AITV	-20°C to +85°C	TO-99
ICL7663BC/D	0°C to +70°C	Dice
ICL7663BCPA	0°C to +70°C	8 Lead Plastic DIP
ICL7663BIJA	-20°C to +85°C	8 Lead CERDIP
ICL7663BITV	-20°C to +85°C	8 Lead TO-99

### Typical Operating Circuit

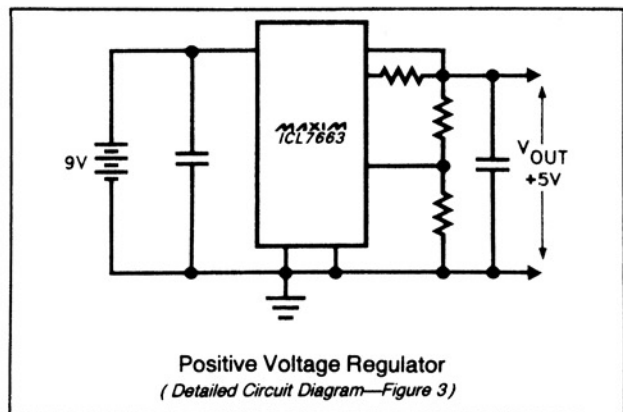

# Programmable Positive Voltage Regulator

## ABSOLUTE MAXIMUM RATINGS

Input Supply Voltage	+ 18V
Any Input or Output Voltage (Note 1) (Terminals 1, 2, 3, 5, 6, 7) (GND - 0.3V) to (V <sub>IN</sub> <sup>+</sup> + 0.3V)	
Output Source Current (Terminal 2)	50mA
(Terminal 3)	25mA

Output Sinking Current (Terminal 7)	- 10mA
Power Dissipation (Note 2)	
Minidip	200mW
TO-99 Can	300mW
Cerdip (Maxim)	500mW

Stresses above those listed under "Absolute Maximum Ratings" may cause permanent damage to the device. These are stress ratings only and functional operation of the device at these or any other conditions above those indicated in the operational sections of the specifications is not implied. Exposure to absolute maximum rating conditions for extended periods may affect device reliability.

## ELECTRICAL CHARACTERISTICS

V<sub>IN</sub><sup>+</sup> = 9V, V<sub>OUT</sub> = 5V, T<sub>A</sub> = +25°C, test circuit unless noted.

PARAMETER	SYMBOL	TEST CONDITIONS	LIMITS			UNIT	
			MIN	TYP	MAX		
Input Voltage	V <sub>IN</sub> <sup>+</sup>	ICL7663	1.5		16.0	V	
		T <sub>A</sub> = 25°C	1.6		16.0	V	
		20°C ≤ T <sub>A</sub> ≤ +70°C					
		ICL7663B	1.5		10	V	
		T <sub>A</sub> = 25°C	1.6		10	V	
		20°C ≤ T <sub>A</sub> ≤ +70°C					
Quiescent Current	I <sub>Q</sub>	$\left\{ \begin{array}{l} R_L = \infty \\ 1.4V \leq V_{OUT} \leq 8.5V \end{array} \right\}$	V <sub>IN</sub> <sup>+</sup> = 16V, ICL7663 only		4.0	12	μA
			V <sub>IN</sub> <sup>+</sup> = 9V		3.5	10	μA
Reference Voltage	V <sub>SET</sub>		1.2	1.3	1.4	V	
Temperature Coefficient	$\frac{\Delta V_{SET}}{\Delta T}$	8.5V < V <sub>IN</sub> <sup>+</sup> < 9V		±200		ppm	
Line Regulation	$\frac{\Delta V_{SET}}{V_{SET} \Delta V_{IN}}$	2V < V <sub>IN</sub> <sup>+</sup> < 15V, ICL7663		0.03		%/V	
		2V < V <sub>IN</sub> <sup>+</sup> < 9V, ICL7663B		0.03		%/V	
V <sub>SET</sub> Input Current	I <sub>SET</sub>			±0.01	10	nA	
Shutdown Input Current	I <sub>SHDN</sub>			±0.01	10	nA	
Shutdown Input Voltage	V <sub>SHDN</sub>	V <sub>SHDN</sub> HI: Both V <sub>OUT</sub> Disabled	1.4			V	
		V <sub>SHDN</sub> LO: Both V <sub>OUT</sub> Enabled			0.3	V	
Sense Pin Input Current	I <sub>SENSE</sub>			0.01	10	nA	
Sense Pin Input Threshold Voltage	V <sub>CL</sub>	V <sub>CL</sub> = V <sub>OUT2</sub> - V <sub>SENSE</sub> (Current-Limit Threshold)		0.7		V	
Input-Output Saturation Resistance (Note 3)	R <sub>SAT</sub>	V <sub>IN</sub> <sup>+</sup> = 2V		200		Ω	
		V <sub>IN</sub> <sup>+</sup> = 9V		70		Ω	
		V <sub>IN</sub> <sup>+</sup> = 15V, ICL7663 only		50		Ω	
Load Regulation	$\frac{\Delta V_{OUT}}{\Delta I_{OUT}}$	ΔI <sub>OUT1</sub> = 100μA @ V <sub>OUT1</sub> = 5V		2.0		Ω	
		ΔI <sub>OUT2</sub> = 10mA @ V <sub>OUT2</sub> = 5V		1.0		Ω	
Available Output Current (V <sub>OUT2</sub> )	I <sub>OUT2</sub>	V <sub>IN</sub> <sup>+</sup> = 3V V <sub>OUT</sub> = V <sub>SET</sub>	10			mA	
		V <sub>IN</sub> <sup>+</sup> = 9V V <sub>OUT</sub> = 5V	25			mA	
		V <sub>IN</sub> <sup>+</sup> = 15V V <sub>OUT</sub> = 5V, ICL7663 only	40			mA	
Negative Tempco Output (Note 4)	V <sub>TC</sub>	Open-Circuit Voltage		0.9		V	
	I <sub>TC</sub>	Maximum Sink Current	0	8	2.0	mA	
Temperature Coefficient	$\frac{\Delta V_{TC}}{\Delta T}$	Open Circuit		+ 2.5		mV/°C	
Minimum Load Current	I <sub>L(min)</sub>	(Includes V <sub>SET</sub> Divider)			1.0	μA	

**Note 1:** Connecting any terminal to voltages greater than (V<sub>IN</sub><sup>+</sup> + 0.3V) or less than (GND - 0.3V) may cause destructive device latch-up. It is recommended that no inputs from sources operating on external power supplies be applied prior to ICL7663 power-up.

**Note 2:** Derate linearly above 50°C at 5mW/°C for minidip and 7.5mW/°C for TO-99 can.

**Note 3:** This parameter refers to the saturation resistance of the MOS pass transistor. The minimum input-output voltage differential at low current (under 5mA), can be determined by multiplying the load current (including set resistor current, but not quiescent current) by this resistance.

**Note 4:** This output has a positive temperature coefficient. Using it in combination with the inverting input of the regulator at V<sub>SET</sub>, a negative coefficient results in the output voltage. See Figure 5 for details. Pin will not source current.

The electrical characteristics above are a reproduction of a portion of Intersil's copyrighted (1983/1984) data book. This information does not constitute any representation by Maxim that Intersil's products will perform in accordance with these specifications. The "Electrical Characteristics Table" along with the descriptive excerpts from the original manufacturer's data sheet have been included in this data sheet solely for comparative purposes.

# MAXIM ADVANTAGE™ Programmable Positive Voltage Regulator

- ◆ 1% Output Voltage Accuracy (ICL7663A)
- ◆ Guaranteed Line and Load Regulation
- ◆ Kev Specifications Guaranteed Over Temperature
- ◆ Improved ESD Protection (Note 5)
- ◆ Improved Output Voltage Temperature Coefficient
- ◆ Maxim Quality and Reliability

**ABSOLUTE MAXIMUM RATINGS:** This device conforms to the Absolute Maximum Ratings on adjacent page.

**ELECTRICAL CHARACTERISTICS** Specifications below satisfy or exceed all "tested" parameters on adjacent page.

$V_{IN}^+ = 9V$ ,  $V_{OUT} = 5V$ ,  $T_A = 25^\circ C$ , test circuit unless noted.

**ICL7663**

PARAMETER	SYMBOL	CONDITIONS	MIN	TYP	MAX	UNITS
Input Voltage	$V_{IN}^+$	ICL7663 $T_A = +25^\circ C$ Over Temperature	1.5		16	V
		ICL7663A Over Temperature	1.6		16	V
		ICL7663B $T_A = +25^\circ C$ Over Temperature	2.0		16	V
Quiescent Current	$I_Q$	$1.4V \leq V_{OUT} \leq 8.5V$ , no load $V_{IN}^+ = 9V$ ICL7663, ICL7663A, Over Temperature ICL7663B, $T_A = 25^\circ C$			10	$\mu A$
		$V_{IN}^+ = 16V$ ICL7663, ICL7663A, Over Temperature			10	$\mu A$
		ICL7663B, $T_A = 25^\circ C$			12	$\mu A$
Reference Voltage	$V_{SET}$	$I_{OUT1} = 100\mu A$ , $V_{OUT} = V_{SET}$ , $T_A = +25^\circ C$ ICL7663, ICL7663B	1.2		1.4	V
		ICL7663A	1.275	1.3	1.325	V
Temperature Coefficient	$\frac{\Delta V_{SET}}{\Delta T}$	Over Temperature		100		ppm/ $^\circ C$
Line Regulation	$\frac{\Delta V_{SET}}{V_{SET} \Delta V_{IN}}$	ICL7663, ICL7663A, $V_{IN} = 2 - 15V$ , Over Temperature		0.03	0.35	%/V
		ICL7663B, $V_{IN} = 2 - 9V$		0.03		%/V
$V_{SET}$ Input Current	$I_{SET}$	ICL7663, ICL7663A, Over Temperature		0.01	10	nA
		ICL7663B, $T_A = +25^\circ C$		0.01	10	nA
Shutdown Input Current	$I_{SHDN}$			$\pm 0.01$	10	nA
Shutdown Input Voltage	$V_{SHDN}$	$V_{SHDNHI}$ : Both $V_{OUT}$ Disabled	1.4			V
		$V_{SHDNLO}$ : Both $V_{OUT}$ Enabled			0.3	V
Sense Pin Input Current	$I_{SENSE}$			0.01	10	nA
Sense Pin Input Threshold	$V_{CL}$			0.5		V
Input-Output Saturation Resistance (Note 3)	$R_{SAT}$	ICL7663A, ICL7663				
		$V_{IN}^+ = 2V$ , $I_{OUT1} = 1mA$		200	500	$\Omega$
		$V_{IN}^+ = 9V$ , $I_{OUT1} = 2mA$		70	150	$\Omega$
		$V_{IN}^+ = 15V$ , $I_{OUT1} = 5mA$		50	100	$\Omega$
Load Regulation	$\frac{\Delta V_{OUT}}{\Delta I_{OUT}}$	ICL7663A, ICL7663				
		$1mA \leq I_{OUT2} \leq 20mA$ $50\mu A \leq I_{OUT1} \leq 5mA$		1	5	$\Omega$
Available Output Current ( $V_{OUT2}$ )	$I_{OUT2}$	$3V \leq V_{IN} \leq 16$ , $V_{IN} - V_{OUT2} = 1.5V$	40			mA
Negative-Tempco Output (Note 4)	$V_{TC}$	Open-Circuit Voltage		0.9		V
	$I_{TC}$	Maximum Sink Current	0	8	2.0	mA
Temperature Coefficient	$\frac{\Delta V_{TC}}{\Delta T}$	Open Circuit		+2.5		mV/ $^\circ C$
Minimum Load Current	$I_{L(min)}$	(Includes $V_{SET}$ Divider) $T_A = +25^\circ C$ Over Temperature			1.0	$\mu A$
				0.2	5	$\mu A$

**Note 1:** Connecting any terminal to voltages greater than ( $V_{IN}^+ + 0.3V$ ) or less than ( $GND - 0.3V$ ) may cause destructive device latch-up. It is recommended that no inputs from sources operating on external power supplies be applied prior to ICL7663 power-up.

**Note 2:** Derate linearly above  $50^\circ C$  at  $5mW/^\circ C$  for plastic minidip,  $7.5mW/^\circ C$  for TO-99 can, and  $10mW/^\circ C$  for CERDIP.

**Note 3:** This parameter refers to the saturation resistance of the MOS pass transistor. The minimum input-output voltage differential at low current (under 5mA), can be determined by multiplying the load current (including set resistor current, but not quiescent current) by this resistance.

**Note 4:** This output has a positive temperature coefficient. Using it in combination with the inverting input of the regulator at  $V_{SET}$ , a negative coefficient results in the output voltage. See Figure 3 for details. Pin will not source current.

**Note 5:** All pins are designed to withstand electrostatic discharge (ESD) levels in excess of 2000V. (Mil Std 883B, Method 3015.1 Test Circuit.)

# Programmable Positive Voltage Regulator

## Typical Operating Characteristics

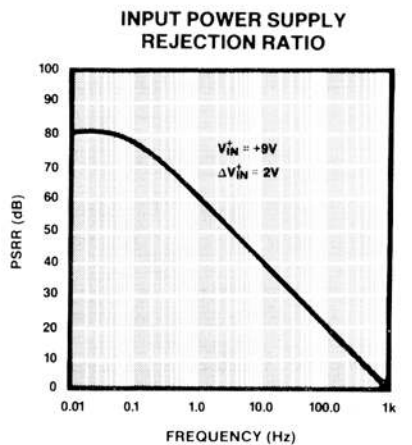
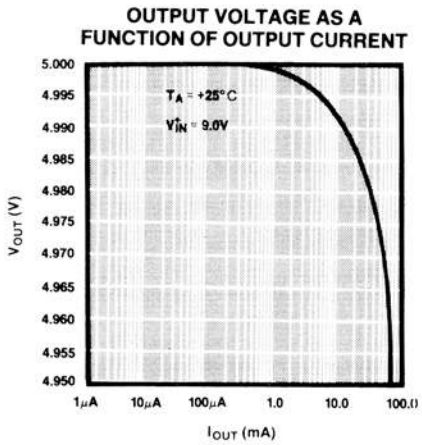
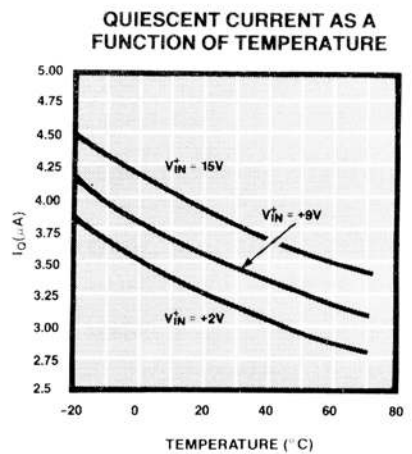
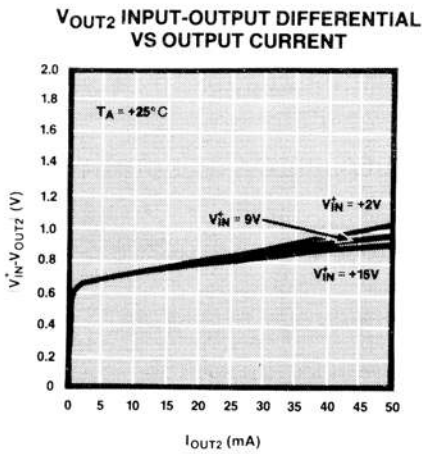
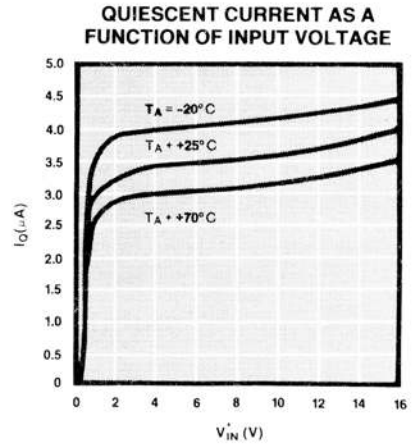
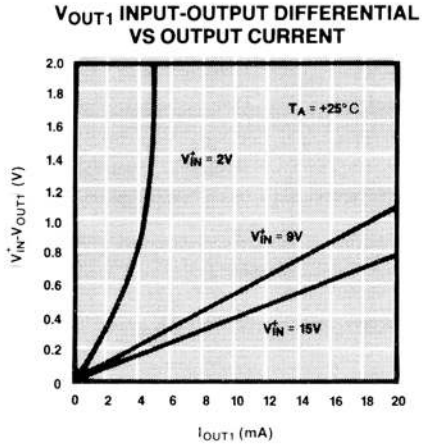

# Programmable Positive Voltage Regulator

ICL7663

## Detailed Description Block Diagram

As shown in the block diagram of Figure 2, the main elements of the ICL7663 are a micropower bandgap reference, an error amplifier, and an output driver with both FET and NPN bipolar transistors.

The bandgap reference of the Maxim ICL7663A, which uses less than  $1\mu\text{A}$  of quiescent current, is precisely trimmed to  $1.30\text{V} \pm 25\text{mV}$ . The output of the bandgap reference and the input voltage at the  $V_{\text{SET}}$  terminal are compared in Amplifier A. This output drives the series pass FET output driver which is connected to  $V_{\text{OUT1}}$ . This output, suitable for output currents less than  $5\text{mA}$ , can drive low current loads with a input-to-output voltage differential that approaches  $0\text{V}$  with low current loads. The minimum input-to-output differential voltage is the product of the output current and the output saturation resistance. For higher current loads, use the  $V_{\text{OUT2}}$  pin. The  $V_{\text{OUT2}}$  pin is driven by an on-chip NPN bipolar transistor whose base is internally connected to the  $V_{\text{OUT1}}$  output. The NPN bipolar transistor of the Maxim ICL7663 can drive up to  $40\text{mA}$  loads with a guaranteed input-to-output differential of  $1.5\text{V}$  maximum.

Also onboard the ICL7663 is a sense comparator that will current limit the output when the voltage across the current sense resistor,  $R_{\text{CL}}$ , is greater than approximately  $0.7\text{V}$ ; a logic shutdown input that turns off the output by logic level control; and an auxiliary output,  $V_{\text{TC}}$ , that has a positive temperature coefficient. Using it in combination with the inverting input of Amplifier A, a negative coefficient results in the output voltage.

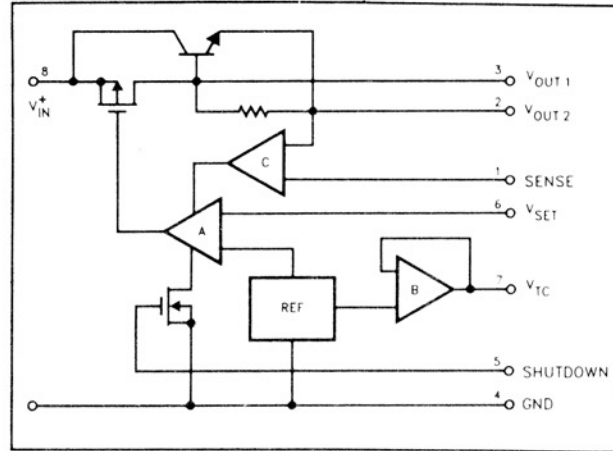

Figure 2. Maxim ICL7663 Block Diagram.

## Basic Circuit Operation

Figure 3 shows a typical positive voltage regulator using the ICL7663. The input voltage,  $V_{\text{IN}}$ , can range from a maximum of  $16\text{V}$  to a minimum of the output voltage plus the input-output differential. The output voltage is set by the resistors  $R_2$  and  $R_1$ , and the output current limit is set by  $R_{\text{CL}}$ . The  $0.047\mu\text{F}$  capacitor on the input limits the rate-of-rise during power-up and also removes some of the high frequency noise on the input voltage. In Figure 3, the logic shutdown is not used and is therefore grounded.  $V_{\text{OUT2}}$  should be connected directly to SENSE if current limiting is not used.

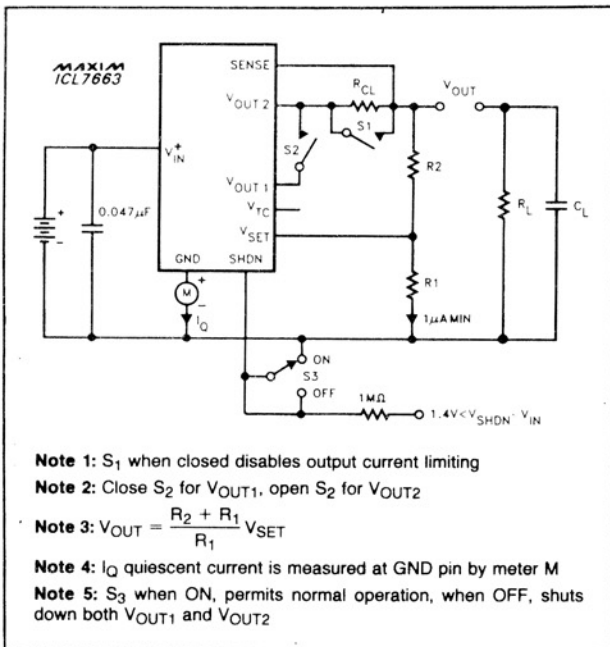

Figure 1. Maxim ICL7663 Test Circuit.

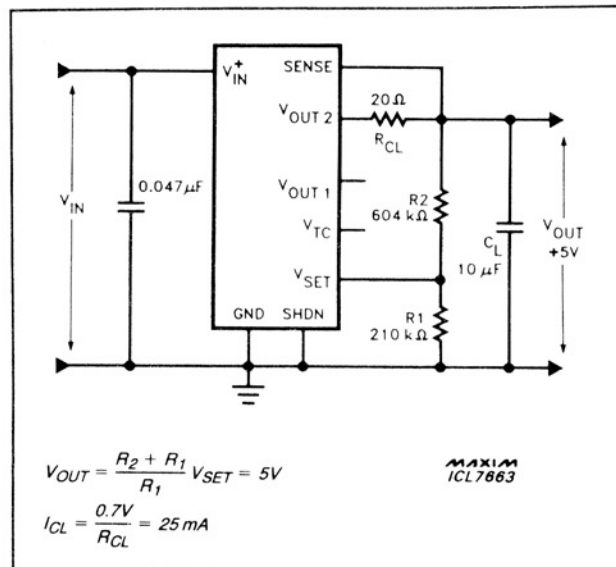

Figure 3. Maxim's Application of ICL7663 (Positive Regulator, Current Limit).

# Programmable Positive Voltage Regulator

## Output Voltage Selection

The output voltage can be calculated from the formula:

$$V_{OUT} = V_{SET} \times \left(1 + \frac{R_2}{R_1}\right) = V_{SET} \times \left(\frac{R_1 + R_2}{R_1}\right)$$

The Maxim ICL7663A  $V_{SET}$  voltage is guaranteed to be  $1.30V \pm 25mV$ , eliminating the need for trim pots in most cases. Specifically, using the Maxim ICL7663A and the resistor values shown in Figure 3, the initial voltage will be within  $\pm 2.7\%$  of 5V, assuming  $\pm 1\%$  tolerance resistors. The output voltage will remain within  $5V \pm 5\%$ , over  $0-70^\circ C$ . This tolerance includes the effect of ICL7663A  $V_{SET}$  error, the  $\pm 1\%$  initial tolerance on both resistors, and the resistor ratio temperature coefficient of nearly 200 ppm/ $^\circ C$ . Since the resistor ratio temperature coefficient is generally much lower than the absolute temperature coefficient, 100 or 200 ppm resistors can be used, even over the full temperature range while still allowing the output to stay within 4.75V–5.25V.

For 5V supplies that have a looser tolerance, the 5% resistor values of 150k $\Omega$  and 430k $\Omega$  or 560k $\Omega$  and 1.6M $\Omega$  are suitable values for R2 and R1. With resistors of  $\pm 5\%$  initial tolerance, the initial output voltage will be  $5V \pm 8.8\%$  and, neglecting the tempco of the resistors, will stay within  $5V \pm 10\%$  over the entire temperature range.

## Current Limiting

The circuit in Figure 3 will limit the output current to approximately 35mA. Current limiting will start, when the output current exceeds 35mA and the voltage drop across the 20 $\Omega$   $R_{CL}$  is 500mV. For other current limits the value of  $R_{CL}$  can be calculated from the formula:

$$R_{CL} = \frac{0.7V}{I_{CL}}; \text{ where } I_{CL} \text{ is the current limit value.}$$

The current limit resistor should be chosen so that neither the 50mA absolute maximum output current specification nor the maximum power dissipation specification is violated.

## Input-Output Differential Voltage

The minimum input-output differential voltage (also called dropout voltage) sets the lower limit for the battery voltage in battery powered supplies. The ICL7663 has a dropout voltage of less than one volt. For example, the ICL7663 will continue to supply a regulated 5V output at 40mA until the battery voltage is less than 6.0V. This is significantly better performance than the standard 3 terminal regulators which require a minimum input-output differential of 2–3V to maintain regulation.

As shown in the Typical Characteristics graphs, the minimum input-output differential for the high current output,  $V_{OUT2}$ , is relatively independent of output current, varying from 0.6V at low current to about 0.9V at 40mA. This minimum 0.6V input-output differential is caused by the base-emitter voltage drop of the NPN bipolar transistor that drives  $V_{OUT2}$ .

By using  $V_{OUT1}$  this 0.6V minimum input-output differential voltage is eliminated, but the required input-output differential rises more rapidly (at the rate set by the output saturation resistance — see Electrical Specifications). Ordinarily, it is advantageous to use  $V_{OUT1}$  for output currents less than 5mA, and to use  $V_{OUT2}$  for higher currents.

If a current limiting resistor is used, the voltage drop across it at the desired operating current must be added to obtain the minimum input-output differential required.

## Output Current Booster

Figure 4 shows a circuit that will supply 5 volts at 1 ampere, with a 6.5V input. The high power external series pass NPN transistor is connected in parallel with the internal NPN transistor. The 100 $\Omega$  resistor in series with  $V_{OUT2}$  keeps the current supplied by the ICL7663, and therefore the power dissipation, within the absolute maximum ratings.

This circuit is particularly useful for battery powered systems that alternately draw high current, then shutdown to extend the battery life.

## Logic Level Shutdown

The ability to turn off the output of the ICL7663 using a single logic level pin is useful in systems where the equipment is on intermittently. By shutting down the output, the total battery drain is reduced to only the quiescent current of the ICL7663, typically 4 $\mu A$ . The shutdown input should preferably be driven by CMOS logic since the input logic low level is only 0.3V. An alternate way of driving is with an open collector PNP transistor and a resistive pull-down. The pull-down resistor need only draw a fraction of a microamp since the Shutdown terminal input current is less than 10nA.

Figure 4 shows a system that will supply up to 1 ampere of output current when active, but will shutdown to 4 $\mu A$  quiescent current by merely switching the Shutdown pin to the high state.

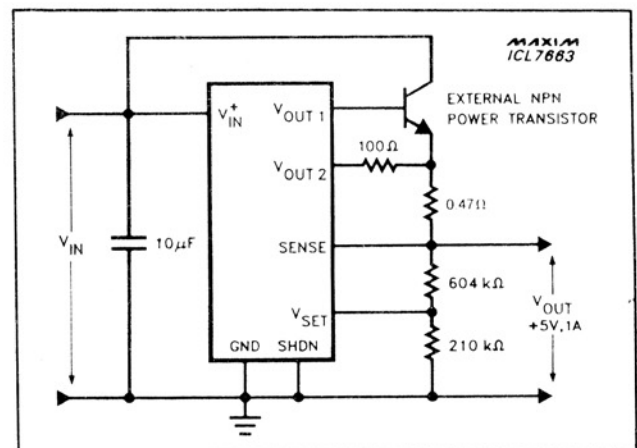

Figure 4. Boosting Output Current with External Transistor.

# Programmable Positive Voltage Regulator

ICL7663

## Negative Temperature Coefficient Output

The  $V_{TC}$  pin has a positive temperature coefficient of about +2.5mV. When connected via a resistor to the inverting summing junction of the error amplifier (the  $V_{SET}$  terminal), this positive coefficient results in a controllable negative temperature coefficient at the output of the ICL7663. Figure 5 shows a simplified diagram of the ICL7663 and the pertinent equations for setting both the output voltage and the output tempo.

Negative output temperature coefficients are most commonly used in multiplexed LCD modules or display systems to compensate for the negative temperature coefficient of the LCD threshold. Figure 6 shows an ICL7663 generating a temperature compensated  $V_{DISP}$  for the Maxim ICM7233 triplexed LCD display driver.

## Cautions

The ICL7663 is designed for low quiescent current battery powered systems and has limited line and load regulation at frequencies above 10Hz. The high frequency load and line regulation is easily improved by adding an output filter capacitor across the load.

As with all junction isolated CMOS devices, the ICL7663 can be destroyed by SCR latchup if standard precautions are not observed. First, no pins should ever be driven more than 0.3V below ground or more than 0.3V above  $V_{IN}^+$ . Secondly, the rate-of-rise on  $V_{IN}^+$  should not be excessive. The rate-of-rise can be several hundred volts per microsecond if the  $V_{IN}^+$  source has a low internal impedance (such as Nicad or lead-acid batteries). There is no current limiting resistance or inductance between the battery and the ICL7663, and there is no input filtering.

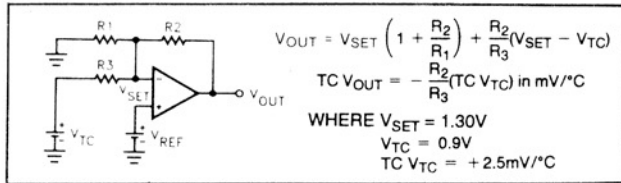

Figure 5. Maxim's Generation of Negative Temperature Coefficients.

Carbon-zinc or alkaline batteries normally do not have sufficient current output capability to cause a rate-of-rise SCR, but the simple addition of a 0.1 $\mu$ F or greater bypass capacitor on the input will ensure that these batteries will not cause SCR latchup.

## $\pm 5V$ Power Supply Using One 9V Battery

The ICL7660 inverts the +9V input voltage to -9V which is then regulated by the ICL7664 negative regulator to a constant -5V output (Refer to Figure 7). The ICL7663 positive voltage regulator uses the +9V input directly to generate a regulated +5V output. The combined quiescent current of the Maxim ICL7660 and the two regulators is less than 100 $\mu$ A, while the output current capability is 40mA. The external oscillator capacitor reduces the oscillation frequency of the ICL7660. This allows the battery voltage to be inverted more efficiently.

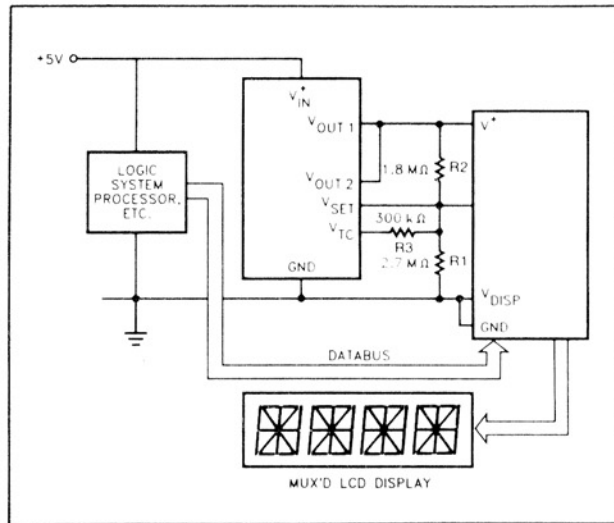

Figure 6. Driving a Multiplexed LCD Display. Consistent operation over more than 40 $^\circ$ C temperature span, as opposed to about 10 $^\circ$ C with a fixed drive voltage, is allowed by negative temperature coefficient drive voltage to the displays. Based on EPSON LDB-728 Display or equivalent.

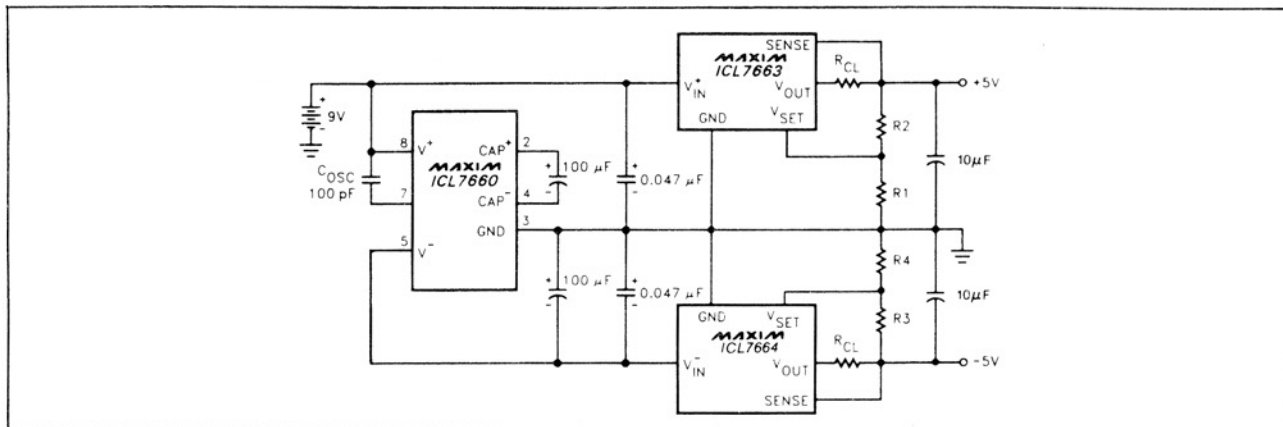

Figure 7.  $\pm 5V$  power supply using one 9V battery.

# Programmable Positive Voltage Regulator

## Package Information

(The package drawing(s) in this data sheet may not reflect the most current specifications. For the latest package outline information go to [www.maxim-ic.com/packages](http://www.maxim-ic.com/packages).)

ICL7663

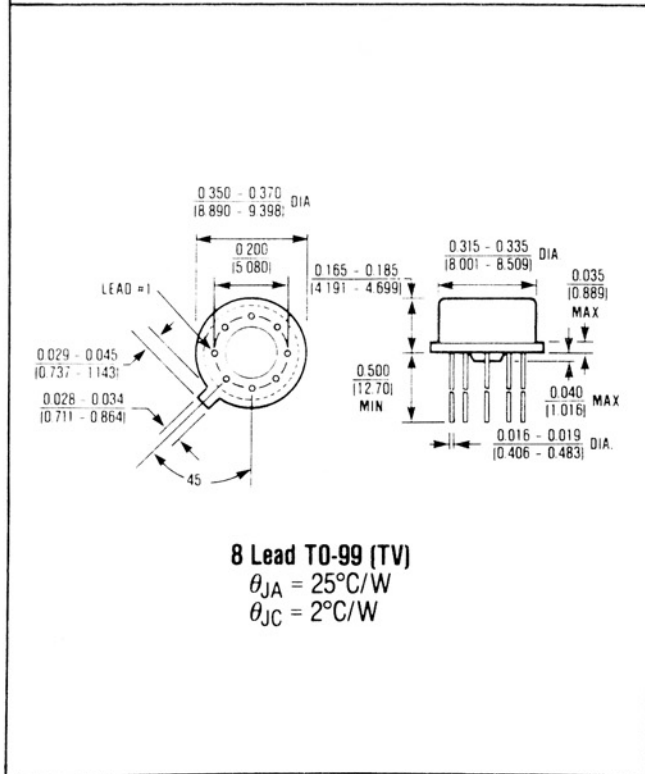
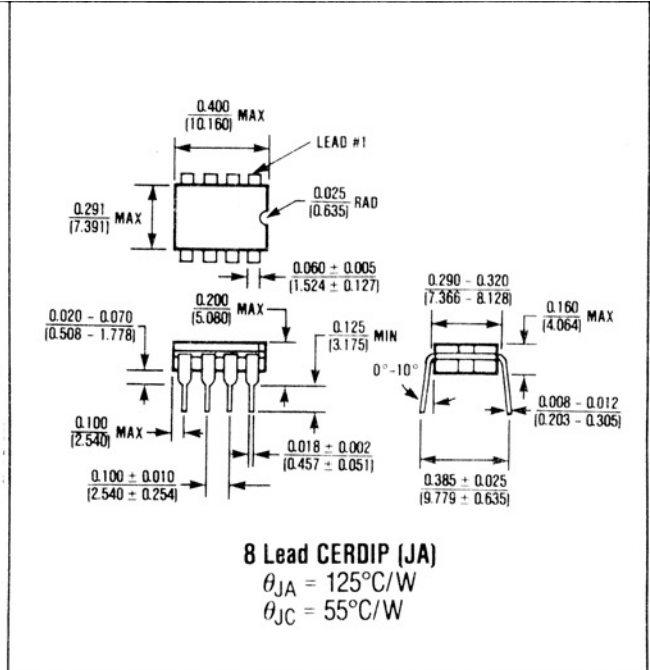
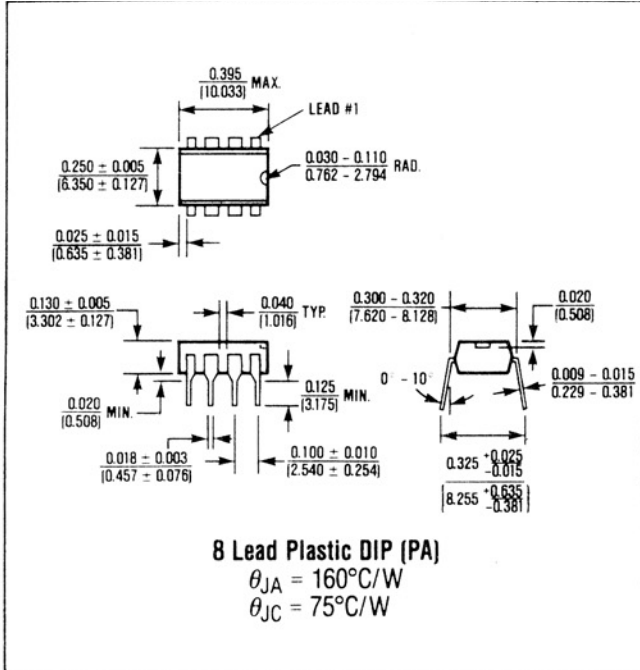

## Chip Topography

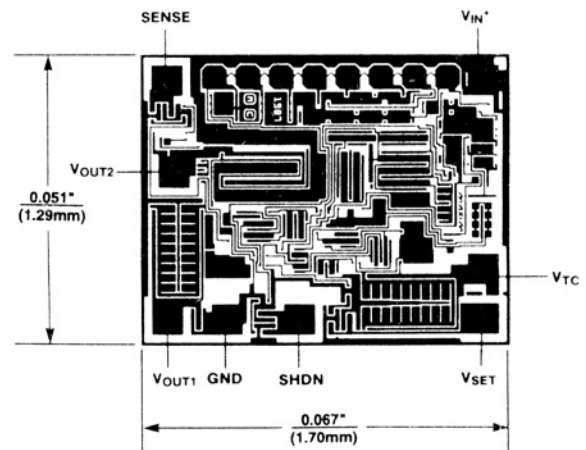

Maxim cannot assume responsibility for use of any circuitry other than circuitry entirely embodied in a Maxim product. No circuit patent licenses are implied. Maxim reserves the right to change the circuitry and specifications without notice at any time.