

REVISONS		DATE	BY	APPV
P	LTR			
C	REV PER ECO	15-005906	5-19-15	CT DM

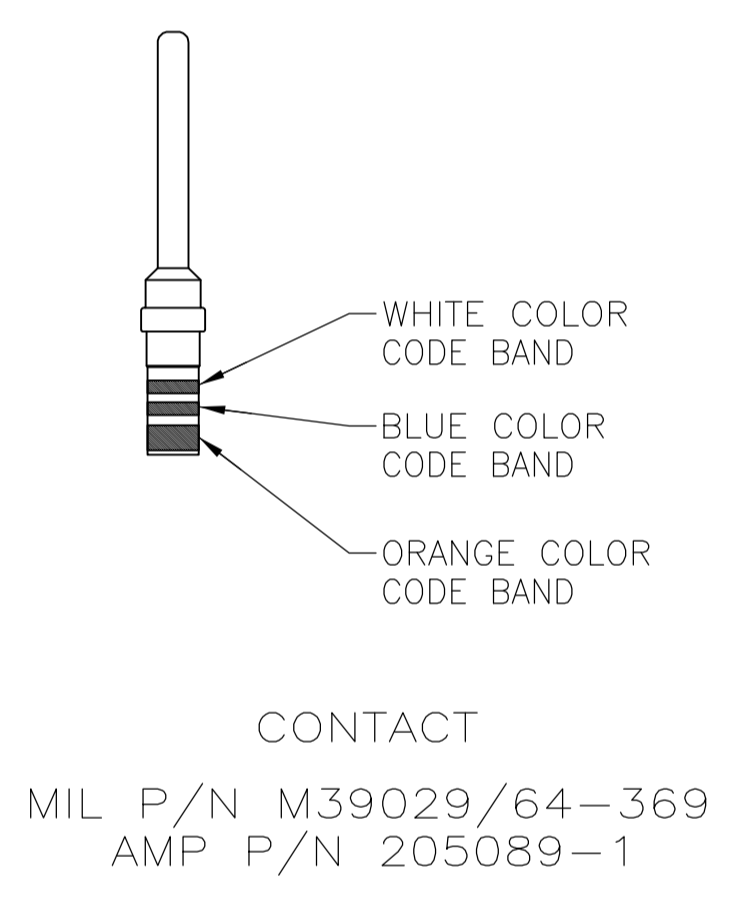

- THIS CONNECTOR ASSEMBLY IS SUPPLIED WITH METAL CONTACT RETENTION CLIPS INSTALLED IN THE INSERT ASSEMBLY.
- THIS CONNECTOR ASSEMBLY MEETS THE REQUIREMENTS OF MIL-C-24308 AND MATES WITH ANY RECEPTACLE CONNECTOR WITH THE SAME INSERT ARRANGEMENT.
- THE PART NUMBER MARKED ON THE CONNECTOR DIFFERS FROM THE PART NUMBER ORDERED DUE TO THE MARKING REQUIREMENTS OF MIL-C-24308/4 (PART NUMBER MARKED ON CONNECTOR REPRESENTS CONNECTOR ASSEMBLY WITH CONTACTS). MARK WITH .047 [1.19]-.062 [1.57] HIGH CHARACTERS. FAR SIDE REFERS TO THE WIDE SIDE OF THE KEYSTONE. NEAR SIDE REFERS TO THE NARROW SIDE OF THE KEYSTONE. IF THE REAR SHELL IS TOO SMALL FOR THE ENTIRE MILITARY PART NUMBER, MARKING SHALL BE LOCATED AS FOLLOWS:
  - "M24308" ON FRONT SHELL, FAR SIDE.
  - SLASH SHEET AND DASH NUMBER ON REAR SHELL, FAR SIDE.
  - "AMP" AND DATE CODE ON FRONT SHELL, NEAR SIDE.
  - AMP PART NUMBER ON REAR SHELL, NEAR SIDE.
 IF THE FRONT SHELL IS TOO SMALL FOR "AMP", AMP PART NUMBER AND DATE CODE, THEN SPLIT AS FOLLOWS:
  - AMP PART NUMBER ON REAR SHELL, NEAR SIDE.
  - "AMP" AND DATE CODE ON FRONT SHELL, NEAR SIDE.
  - MILITARY PART NUMBER ON REAR SHELL, FAR SIDE.
- REQUIREMENT FOR FULL PIN DIAMETER EXTENSION:
  - .164 [4.17] MIN, SHELL SIZES 1 AND 2.
  - .155 [3.94] MIN, SHELL SIZES 3, 4, AND 5.
  - CONTACT SHOWN INSTALLED FOR DIMENSIONAL REFERENCE ONLY.
- MAXIMUM WIRE INSULATION TO BE USED WITH THIS CONNECTOR ASSEMBLY IS .072 [1.83] DIAMETER.
- FOR CONTACT CRIMPING INSTRUCTION SHEET REFER TO AMP IS 408-7516. FOR CONTACT INSTALLATION AND REMOVAL INSTRUCTION SHEET REFER TO AMP IS 408-7508.
- FLOAT SPECIFICATIONS ARE .004 [0.10]-.012 [0.30] VERTICALLY AND .026 [0.66]-.036 [0.91] HORIZONTALLY.
- PART NUMBER FOR ORDERING.
- DIMENSIONS AND TOLERANCES PER ANSI Y14.5M-1982.
- THIS DRAWING SHALL BE INTERPRETED IN ACCORDANCE WITH APPLICABLE STANDARDS LISTED IN MIL-STD-100.

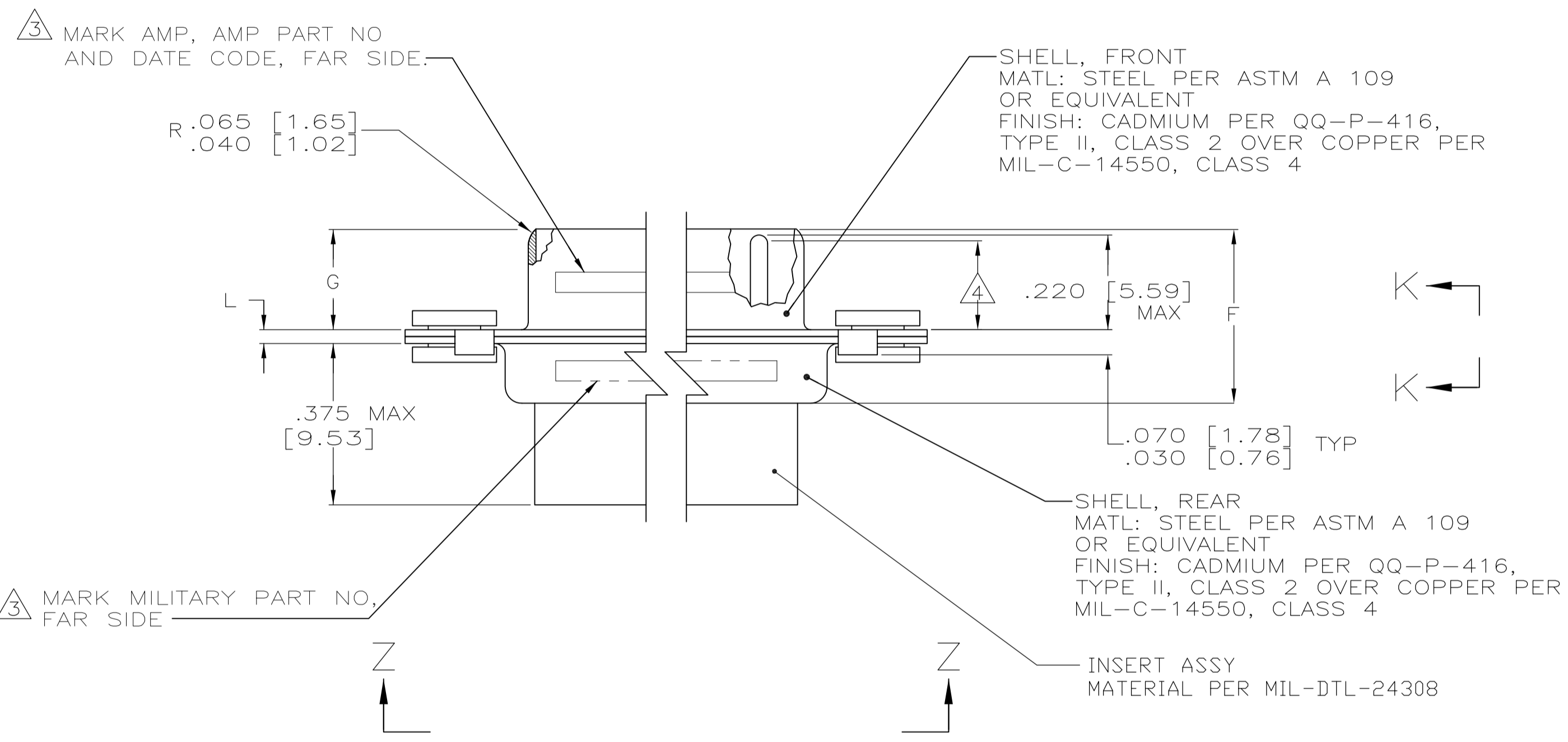
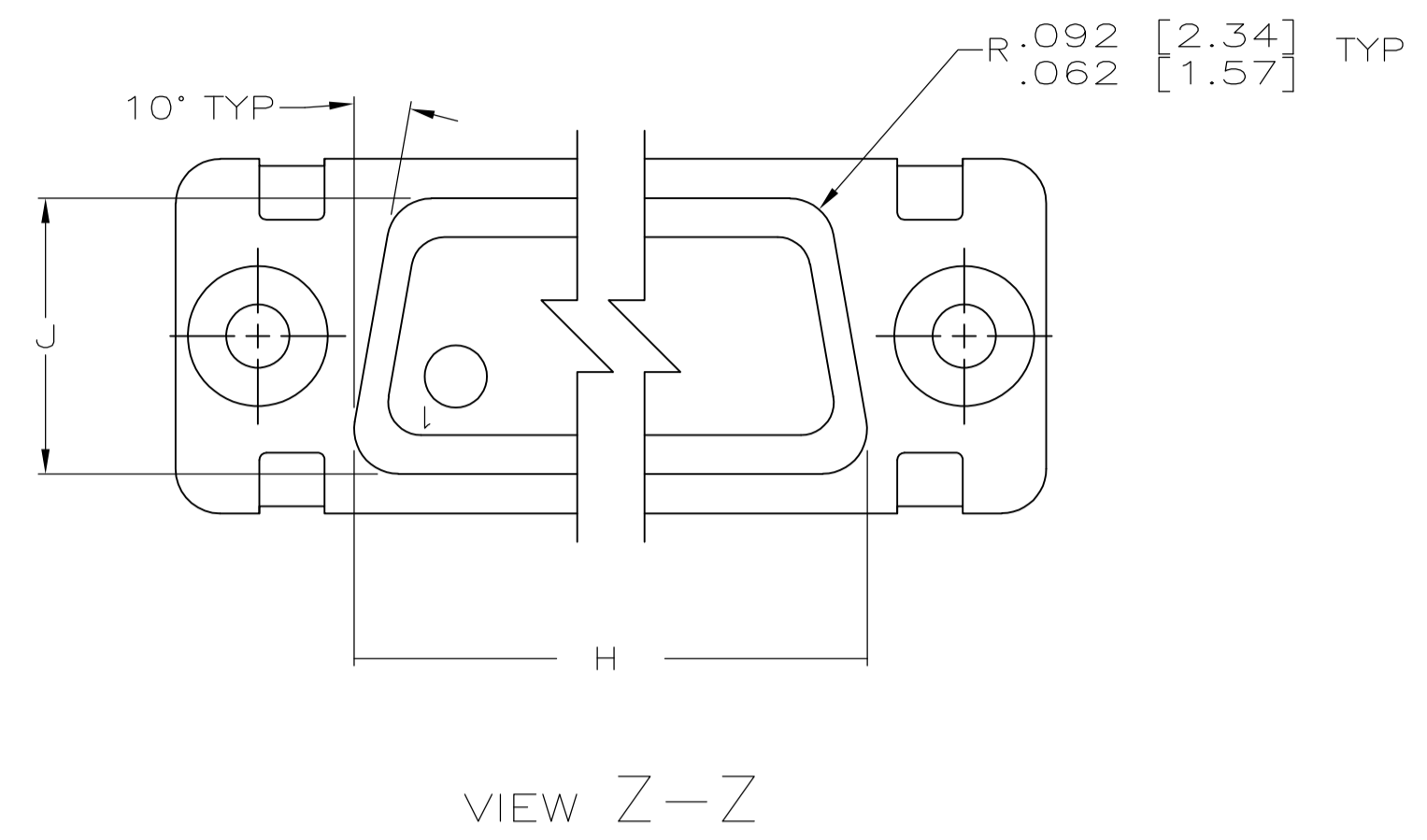
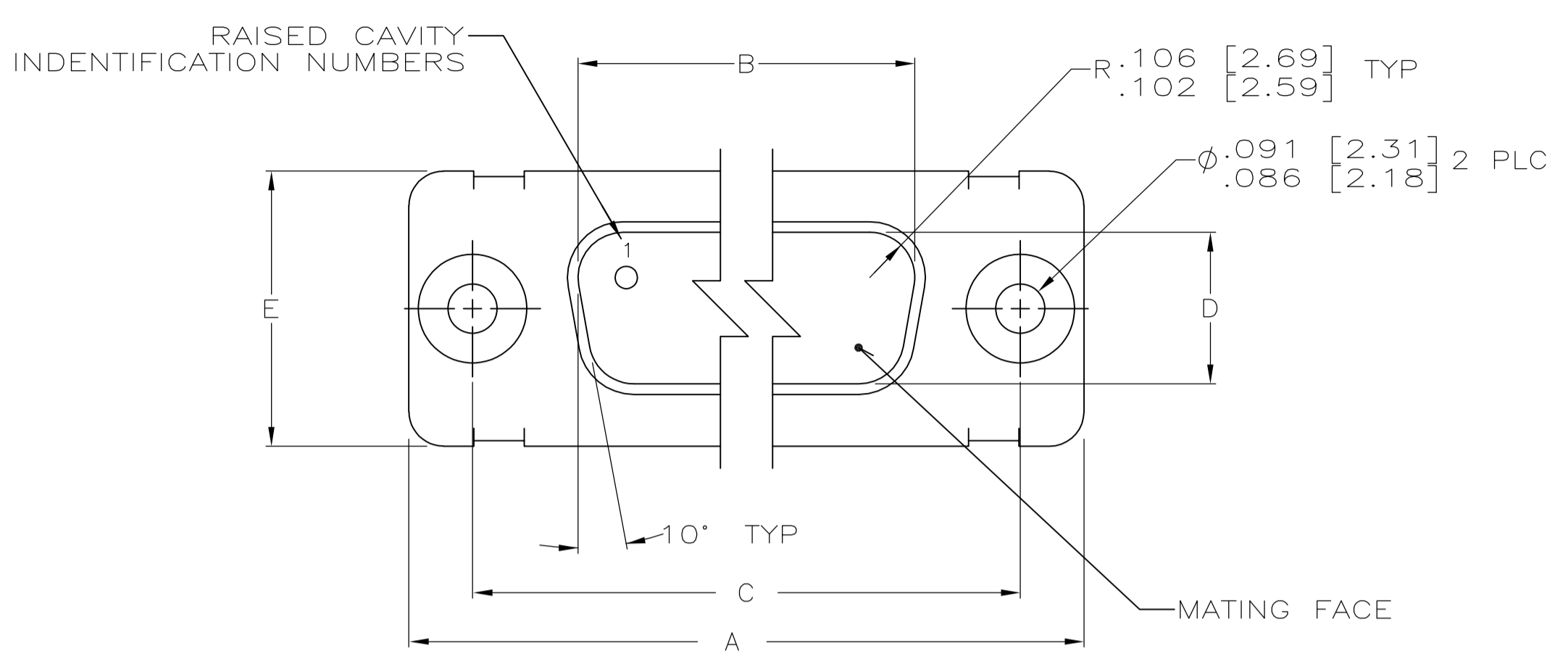
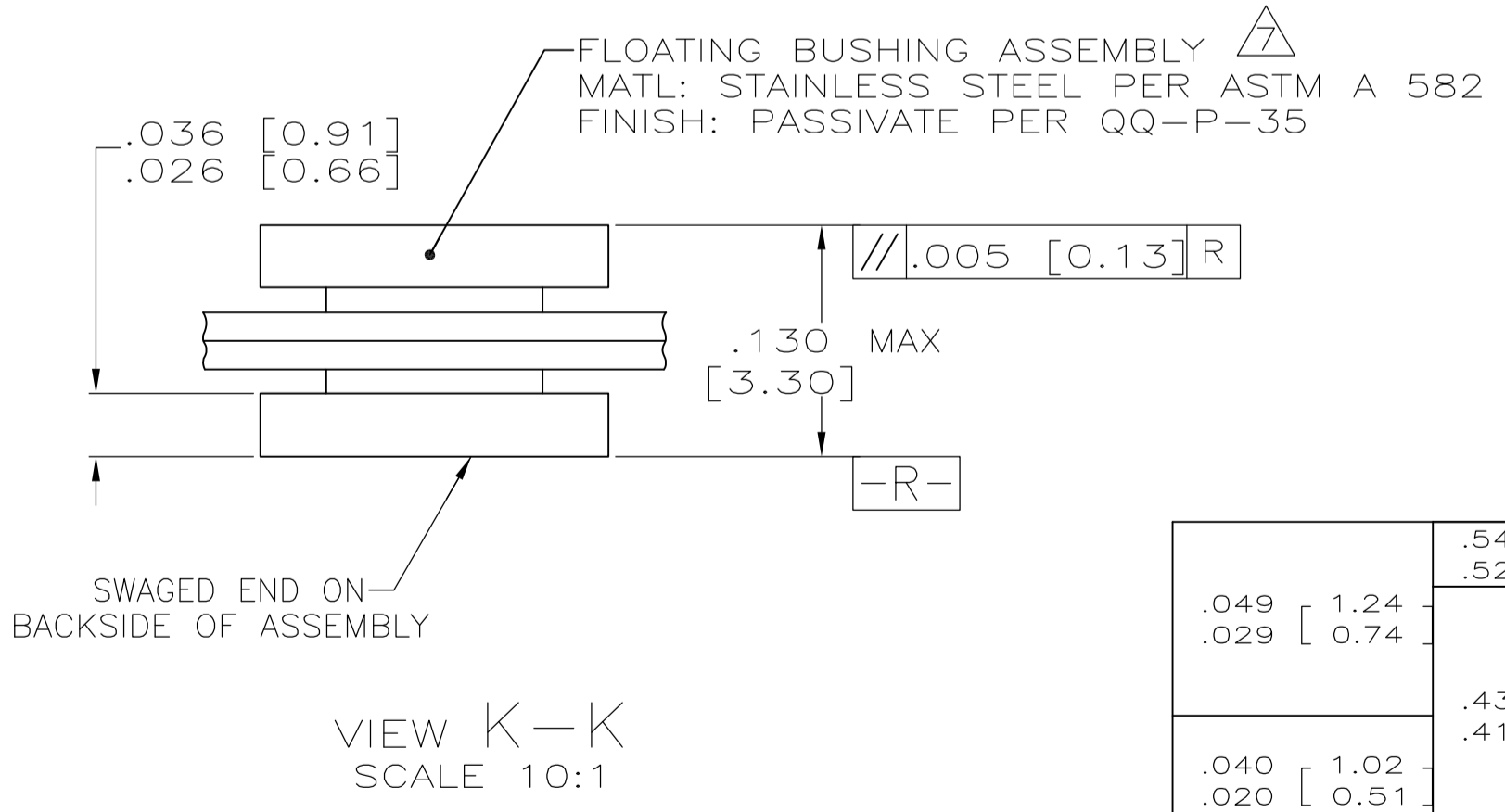
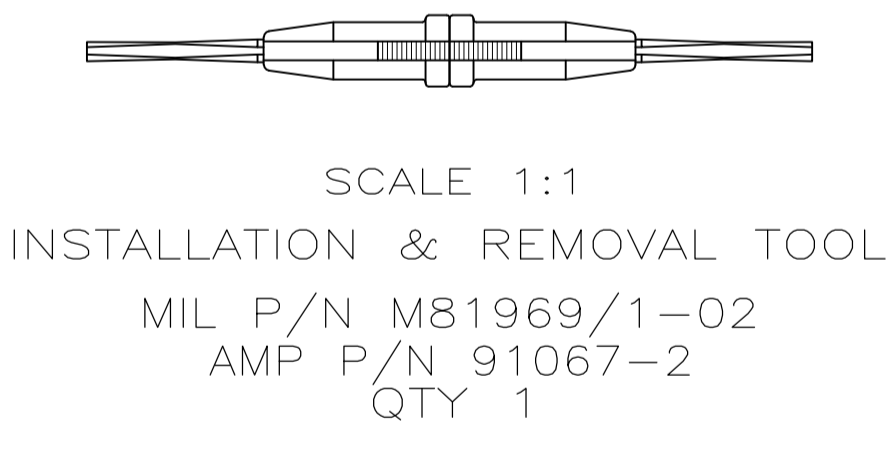

L	J	H	G	F	E	D	C	B	A	INSERT ARRANGEMENT	NO OF POS	SHELL SIZE	PACKAGE MILITARY P/N	MILITARY P/N ON CONNECTOR	AMP P/N ON CONNECTOR	PART NUMBER
.049 [1.24]	.544 [13.82]	2.188 [55.58]	.236 [5.99]	.436 [11.07]	.620 [15.75]	.446 [11.33]	2.411 [61.24]	2.084 [52.93]	2.650 [67.31]	MS18277-1	50	5	M24308/4-317F	M24308/4-306F	593030-5	593032-5
.029 [0.74]	.524 [13.31]	2.168 [55.07]	.224 [5.69]	.416 [10.57]	.590 [14.99]	.436 [11.07]	2.401 [60.99]	2.074 [52.68]	2.620 [66.55]	MS18276-1	37	4	M24308/4-316F	M24308/4-305F	593030-4	593032-4
		1.635 [41.53]					1.857 [47.17]	1.539 [39.09]	2.103 [53.42]	MS18275-1	25	3	M24308/4-315F	M24308/4-304F	593030-3	593032-3
	.432 [10.97]	1.615 [41.02]			.509 [12.93]	.334 [8.48]	1.847 [46.91]	1.529 [38.84]	2.073 [52.65]	MS18274-1	15	2	M24308/4-314F	M24308/4-303F	593030-2	593032-2
.040 [1.02]	.412 [10.46]	1.093 [27.76]	.241 [6.12]	.432 [10.97]	.479 [12.17]	.324 [8.23]	1.317 [33.45]	.999 [25.37]	1.556 [39.52]	MS18273-1	9	1	M24308/4-313F	M24308/4-302F	593030-1	593032-1
.020 [0.51]		1.073 [27.25]	.229 [5.82]	.412 [10.46]			1.307 [33.20]	.989 [25.12]	1.526 [38.76]							
		.769 [19.53]					.989 [25.12]	.671 [17.04]	1.228 [31.19]							
		.749 [19.02]					.979 [24.87]	.661 [16.79]	1.198 [30.43]							

THIS DRAWING IS A CONTROLLED DOCUMENT.

DIMENSIONS: INCHES	TOLERANCES UNLESS OTHERWISE SPECIFIED:	APVD: F. KINSEY	DATE: 10-29-92
0 PLC ± .005	1 PLC ± .005	NAME: AJ GRAFF	DATE: 10-20-92
2 PLC ± .005	3 PLC ± .005	CHK: B. GILLMAN	DATE: 10-29-92
4 PLC ± .005	ANGLES ± .005	DATE: 10-29-92	

MATERIAL: SEE CALLOUTS  
FINISH: SEE CALLOUTS

WEIGHT: —  
CUSTOMER DRAWING

SCALE: 4:1  
SHEET: 1 OF 1  
REV: C

STE TE Connectivity  
AMPLIMITE PLUG ASSY WITH SERIES 109, FLOATING BUSHING, SHELL SIZES 1 THRU 5  
MIL-C-24308  
SIZE: A1  
CAGE CODE: 00779  
DRAWING NO: 593032