

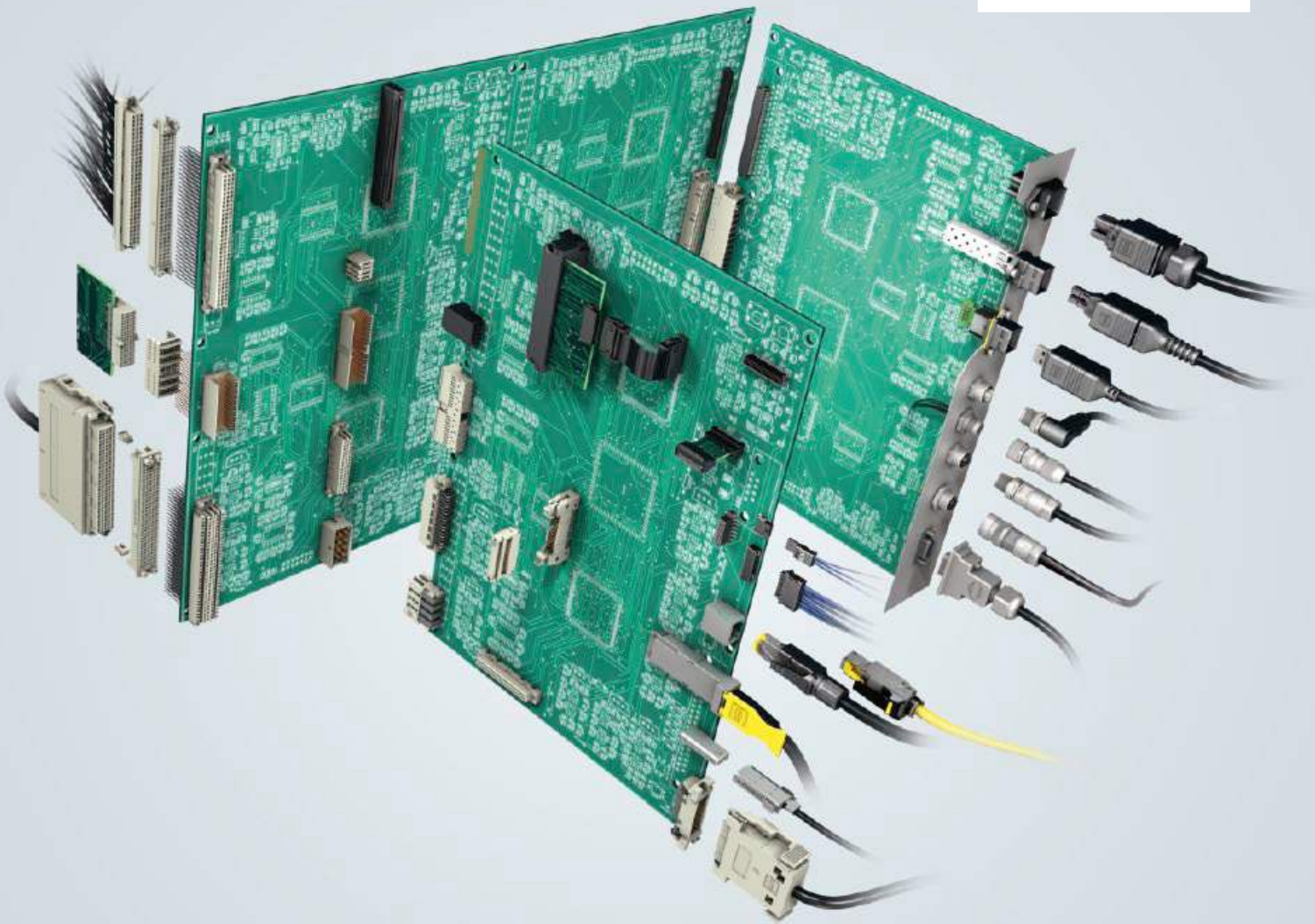

Pushing Performance



People | Power | Partnership

HARTING

Device Connectivity

Transforming customer wishes into concrete solutions



The HARTING Technology Group is skilled in the fields of electrical, electronic and optical connection, transmission and networking technology, as well as in manufacturing, mechatronics and software creation. The Group uses these skills to develop customized solutions and products such as connectors for energy and data-transmission/data-networking applications, including, for example, mechanical engineering, rail technology, wind energy plants, factory automation and the telecommunications sector. In addition, HARTING also produces electro-magnetic components for the automobile industry and offers solutions in the field of hoisting technology and shop systems.

The HARTING Group currently comprises 53 sales companies and production plants worldwide employing a total of about 4,200 staff.



HARTING Subsidiary



HARTING Representation

We aspire to top performance.

Connectors ensure functionality. As core elements of electrical and optical termination, connection and infrastructure technologies, they are essential in enabling the modular construction of devices, machines and systems across an extremely wide range of industrial applications. Their reliability is a crucial factor guaranteeing smooth functioning in the manufacturing area, telecommunications, applications in medical technology – in short, connectors are at work in virtually every conceivable application area. Thanks to the ongoing development of our technologies, our customers enjoy investment security and benefit from durable, long-term functionality.

Wherever our customers are, we're there.

Increasing industrialization is creating growing markets that are characterized by widely diverging demands and requirements. What these markets all share in common is the quest for perfection, increasingly efficient processes and reliable technologies. HARTING is providing these technologies – in Europe, the Americas and Asia. In order to implement customer requirements in the best possible manner, the HARTING professionals at our international subsidiaries engage in up-close, partnership-based interaction with our customers, right from the very early product development phase.

Our on-site staff form the interface to the centrally coordinated development and production departments. In this way, our customers can rely on consistently high, superior product quality – worldwide.

Our claim: Pushing Performance.

HARTING provides more than optimally attuned components. In order to offer our customers the best possible solutions, on request HARTING contributes a great deal more and is tightly integrated into the value-creation process.

From ready-assembled cables through to control racks or ready-to-go control desks. Our aim is to generate maximum benefit for our customers – with no compromises!

Quality creates reliability – and warrants trust.

The HARTING brand stands for superior quality and reliability – worldwide. The standards we set are the result of consistent, stringent quality management that is subject to regular certifications and audits.

EN ISO 9001, the EU Eco-Audit and ISO 14001 are key elements here. We take a proactive stance towards new requirements, which is why HARTING is the first company worldwide to have obtained the IRIS quality certificate for rail vehicles.



HARTING technology creates added value for customers.

Technologies by **HARTING** are at work worldwide. **HARTING**'s presence stands for smoothly functioning systems powered by intelligent connectors, smart infrastructure solutions and sophisticated network systems. Over the course of many years of close, trust-based cooperation with its customers, the **HARTING** Technology Group has become one of the leading specialists globally for connector technology. We offer individual customers specific and innovative solutions that go beyond the basic standard functionalities. These tailored solutions deliver sustained results, ensure investment security and enable customers to achieve significant added value.

Opting for HARTING opens up an innovative, complex world of concepts and ideas.

In order to develop and produce connectivity and network solutions serving an exceptionally wide range of connector applications in a professional and cost-effective manner, **HARTING** not only commands the full array of conventional tools and basic technologies. Above and beyond these capabilities, **HARTING** is constantly harnessing and refining its broad base of knowledge and experience to create new solutions that also ensure continuity. To secure its lead in know-how, **HARTING** draws on a wealth of sources from its in-house research and applications.

Salient examples of these sources of innovative knowledge include microstructure technologies, 3D design and connection technol-

ogy, high-temperature and ultrahigh-frequency applications that are finding use in telecommunications and automation networks, in the automotive industry, or in industrial sensor and actuator applications, RFID and wireless technologies, in addition to packaging and housing made of plastics, aluminum and stainless steel.

HARTING overcomes technological limitations.

Drawing on the comprehensive resources of the group's technology pool, **HARTING** devises practical solutions for its customers. Whether this involves industrial networks for manufacturing automation, or hybrid interface solutions for wireless telecommunication infrastructures, 3D circuit carriers with microstructures, or cable assemblies for high-temperature applications in the automotive industry – **HARTING** technologies offer not only components, but comprehensive solutions attuned to individual customer requirements and preferences. The range of cost-effective solutions covers ready-to-use cable configurations, completely assembled backplanes and board system carriers, as well as fully wired and tested control panels.

In order to ensure the future-proof design of RF and EMC-compatible interface solutions, the central **HARTING** laboratory (accredited according to DIN EN ISO/IEC 17 025) employs simulation tools, as well as experimental, testing and diagnostics facilities all the way to Industrial computed tomography. In addition to product and process suitability considerations, lifecycle and environmental aspects play a key role in the selection of materials and processes.



HARTING's knowledge is practical know-how that generates synergy effects.

HARTING commands decades of experience with regard to the applications conditions involved in connections in telecommunications, computer, network and medical technologies, as well as industrial automation technologies, e.g. in the mechanical engineering and plant engineering areas, in addition to the power generation industry and the transportation sector. HARTING is highly

conversant with the specific application areas in all of these technology fields. In every solution approach, the key focus is on the application. In this context, uncompromising, superior quality is our hallmark. Every new solution found invariably flows back into the HARTING technology pool, thereby enriching our resources. And every new solution we go on to create will draw on this wealth of resources in order to optimize each and every individual solution. HARTING is synergy in action.

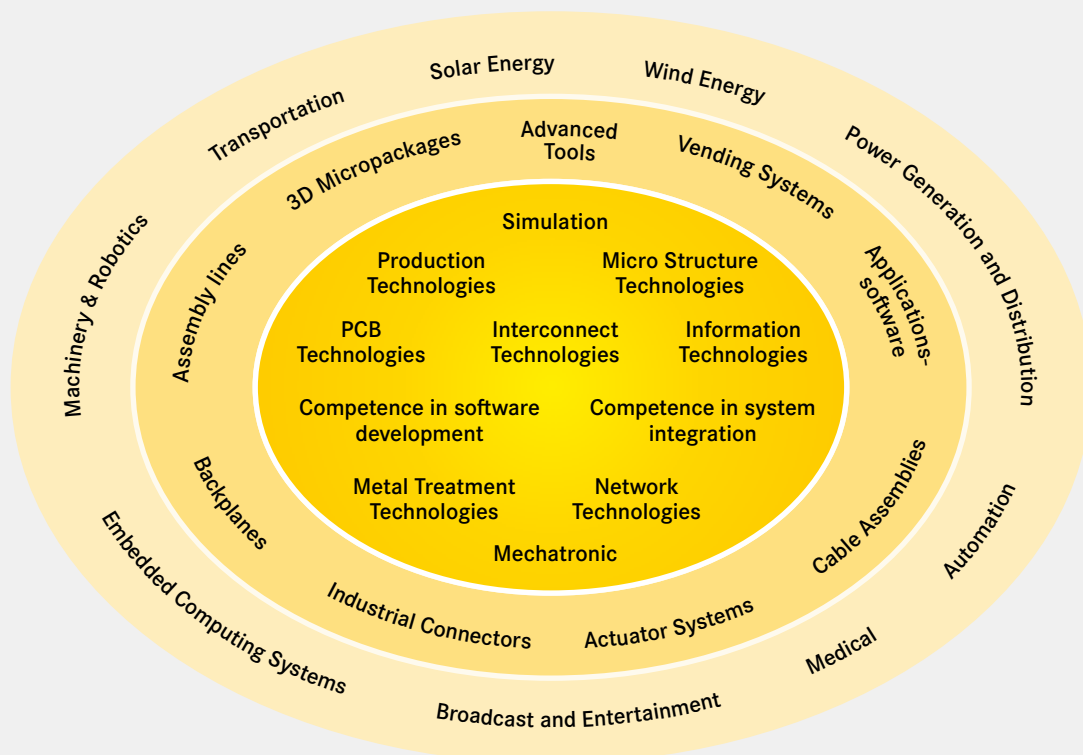

Smart Network Infrastructure



INTELLIGENT NETWORK SOLUTIONS

With its product series Ha-VIS, HARTING offers a consistent range of Ethernet network components and cabling products, which form the communication platform of convergent

automation IT networks. Under Ha-VIS HARTING offers fully integrated RFID solutions.

Installation Technology



INDUSTRIAL CONNECTORS Han®

This catalogue documents the worldwide standard for industrial connectors. Han® connectors represent the preferential solution in the cable-to-cable interconnection of data, signal and power

applications operating under the most demanding conditions and meeting stringent requirements with regard to safe and detachable electrical connections with high degree of protection IP65 / IP67. Installations making use of Han® connectors impress with their rugged design, convenient handling and modularity of data, signal and power connections. Han® connectors represent the worldwide standard in industry, railway technology, as well as in power generation and distribution.

Device Connectivity



DEVICE CONNECTIVITY

The Device Connectivity catalogue provides a universal, innovative product portfolio of PCB connections and of termination technology. The product range comprises board-to-

board and cable-to-board connectors for industrial electronic devices with degree of protection IP20 to IP65 / IP67. These HARTING solutions offer appropriate device connectivity for a wide range of devices, ranging from sensors to industrial computers and their respective data, signal and power interfaces.

Contents

Chapter

HARTING RJ Industrial® – RJ45 Ethernet Connectors	01
PushPull Connectors	02
Circular Connectors	03
Industrial Connectors Han®	04
Subminiature D Connectors	05
<i>har-mik</i> ® Interface Connectors – Since 2016 the <i>har-mik</i> ® product family is not any more part of HARTING's product portfolio.	
<i>har-link</i> ® Interface Connectors	07
SEK IDC Connectors	08
DIN 41612 Connectors	09
Mini Coax Connectors	10
<i>har-bus</i> ® HM Connectors	11
TCA Connectors	12
Micro Card Edge Connectors	13
<i>har-flex</i> ® Connectors	14
<i>har-flexicon</i> ® Connectors	15
Tools	20
Custom Device Connectivity	31
Technical Appendix	40



CABLE- / WIRE-TO-BOARD

Whatever your applications may be, HARTING has the ideal solutions for your data, signal and power connectivity requirements with its matching cable-to-board and wire-to-board technologies with degree of protection IP20 to IP65 / IP67.

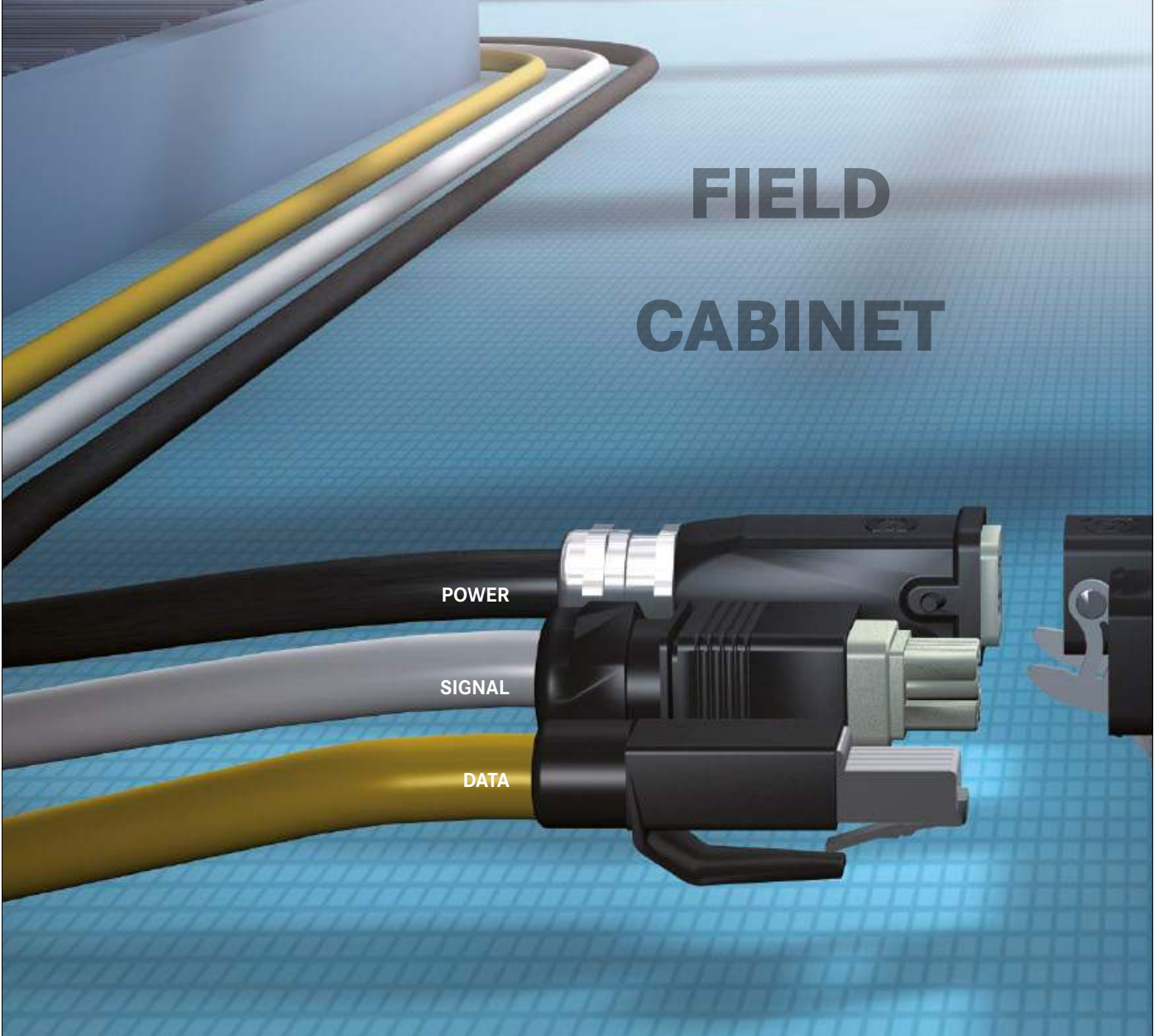

FIELD CABINET

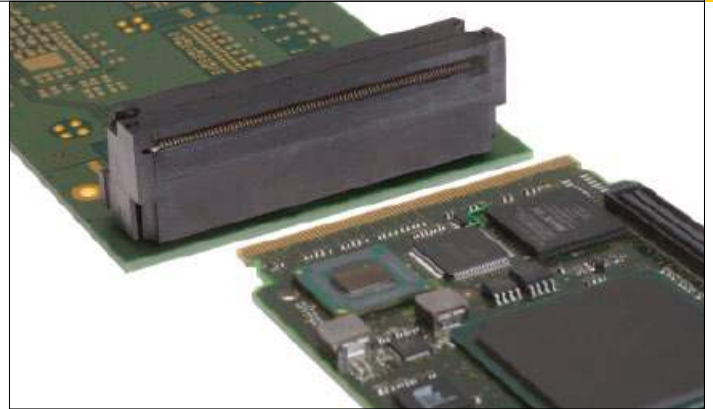

BOARD-TO-BOARD

Regardless of your device configuration, HARTING always has an ideal board-to-board connector with maximum packing density and optimal performance with regard to signal transmission and integrity.

DEVICE



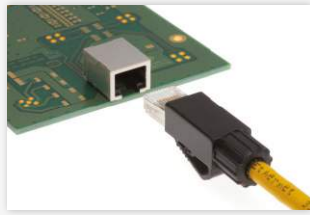

01. HARTING RJ INDUSTRIAL® – RJ45 ETHERNET CONNECTORS

HARTING offers a wide range of RJ45 contact inserts and matching RJ45 connectors for quick and reliable termination of your 2- or 4-pair Ethernet cables. The RJ Industrial connector family also supports Ethernet automation profiles such as PROFINET, Ethernet/IP, EtherCAT and Powerlink. The HARTING RJ Industrial® connectors provide standard RJ45 connection technology for the industrial field level.



02. PushPull CONNECTORS

HARTING has set the standard for connection technology for innovative IP65 / IP67 installation concepts with its new generation of the PushPull series. The multifunctional PushPull connector is available for data, signal and power applications and provides a concept with many connector mating faces. The universal PushPull product line is complemented by additional interfaces such as USB, LC or SCRJ.



03. CIRCULAR CONNECTORS

HARTING offers a comprehensive portfolio of M8, M12, M23, 7/8" and Han-Max® circular connectors for industrial applications. In addition to assembled system cables, HARTING also offers connectors with HARAX® fast termination technology for onsite installation directly in the field.



04. INDUSTRIAL CONNECTORS Han®

Han® industrial connectors with degree of protection IP65 / IP67 represent the worldwide connector standard with regard to safe installation, efficient commissioning and servicing of machines and plants

Power

Signal



05. Subminiature D Connectors

D-Sub connectors are a classic solution for cable-to-board applications. Thanks to their versatility, they represent a universal solution for applications in the field of device connectivity, and offer a wide range of data, signal and power connection technology for applications in automation systems.

Data



07. har-link® INTERFACE CONNECTORS

The har-link® connector is characterized by its ability to handle the highest data rates in combination with perfect shielding functions. HARTING complements the har-link® connector family by assembled system cables with shielded and unshielded twisted-pair design.

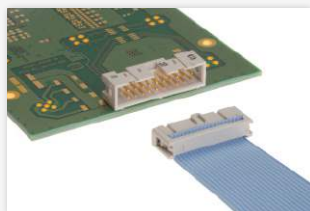

08. SEK INSULATION DISPLACEMENT CONNECTORS

IDC connectors for flat ribbon cables facilitate the simple and cost-effective configuration of devices and are preferably implemented as internal connections. HARTING offers a wide range of these cable-to-board connectors.



09. DIN 41 612 CONNECTORS

For many years, connectors to DIN 41 612 have established themselves as a standard both for board-to-board and cable-to-board applications. HARTING offers a wide product range of DIN 41 612 connectors for data, signal and power lines, including corresponding accessories.



10. Mini Coax CONNECTORS

Mini Coax connectors facilitate multi-channel, coaxial and highfrequency data transmission for board-to-board and cable-to-board applications. Device integration is supported with straight and angled contact inserts with press-in technology and SMT/ SMC. The housings support applications up to IP65.

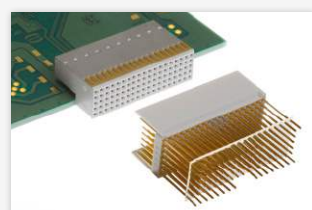

11. har-bus[®] HM CONNECTORS

har-bus[®] HM connectors form the basis for the assembly of high-performance backplanes for control systems and for industrial computer systems with 19" technology. The board-to-board connectors are available with press-in technology for backplanes and solder versions for sub-boards.



12. TCA CONNECTORS

TCA connectors represent the next generation of backplane connectors. Their new concept supports direct or indirect connection. TCA connector versions are available for connecting data channels and the power supply to the modules.



13. MICRO CARD EDGE CONNECTORS

The HARTING Micro Card Edge connector for applications requiring board-to-board mezzanine or small pluggable daughter card connections. The key feature is the very flexible stacking height of parallel boards by utilizing a small board between the connectors.



14. har-flex[®] CONNECTORS

HARTING's new har-flex[®] connector series is a space-saving, rugged and flexible PCB connector for the widest range of board-to-board and board-to-cable applications. In addition to straight connector models, the product family also includes compatible insulation displacement connectors, along with angled models.

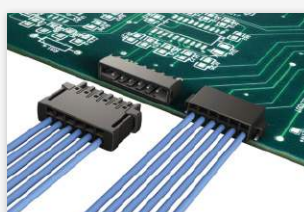

15. har-flexicon[®] PCB TERMINAL BLOCKS AND CONNECTORS

har-flexicon[®] is the robust PCB termination technology for single wires. Components for the termination of industrial devices in the pitches of 1.27 mm, 2.54 mm, 3.50/3.81 mm and 5.00/5.08 mm are available. All components are particularly suited for reflow-soldering on the PCB and offer field assembly with PushIn and insulation displacement termination for single wires.

PRODUCT GROUP	CONNECTION TYPE		ENVIRONMENT		Data
	Board to Board	Cable / Wire to Board	IP20	IP65 / IP67	
01 HARTING RJ Industrial® – RJ45 Ethernet Connectors		●	●		●
02 PushPull Connectors		●		●	●
03 Circular Connectors		●		●	●
04 Industrial Connectors Han®		●		●	●
05 Subminiature D Connectors	●	●	●	●	●
07 <i>har-link</i> ® Interface Connectors		●	●		●
08 SEK IDC Connectors		●	●		●
09 DIN 41 612 Connectors	●	●	●		●
10 Mini Coax Connectors	●	●	●		●
11 <i>har-bus</i> ® HM Connectors	●		●		●
12 TCA Connectors	●		●		●
13 Micro Card Edge Connectors	●		●		●
14 <i>har-flex</i> ® Connectors	●	●	●		●
15 <i>har-flexicon</i> ® Connectors and PCB terminal blocks	●	●	●		●

APPLICATION						APPLICATION STANDARD	
Signal	Power	high performance				Voltage/ current	
		Data rate	Shielding	Number of poles/ contact density			
		*10 Gbit category 6A					
		*10 Gbit Cu & LWL					
		*10 Gbit Cu & LWL				*40 A @ 400 V	
						*40 A 4 kV	
		*> 1.5 Gbit					
						*40 A 2.8 kV	
		*4 GHz					
		*> 6 Gbit				*16 A	
		*14 Gbps					
						*600 V / 17.5 A	

We ensure convincing connectivity for each and every device you bring to the markets.

HARTING will develop the ideal connectivity for your devices in cooperation with your product management and device developers. For us, this means: Design-in support.

HARTING, THE SPECIALIST FOR INDUSTRIAL DEVICE CONNECTIVITY

The versatility of industrial electronic devices and the potential solutions for device connectivity go hand in hand.

HARTING supports industrial electronic systems with a wide standard portfolio of device connectivity for data, signal and power applications.

This portfolio facilitates the comfortable and quick implementation of the majority of connectivity solutions. Future device generations are frequently subject to specific requirements in terms of their interfaces. In order to implement Device Connectivity solutions that are tailored to these requirements, we utilize all expert resources of the HARTING Technology Group, drawing on our in-house development, tool production, extensive vertical range of manufacture and our accredited test laboratories. The connectivity of future industrial device generations is driven by market trends towards minimization of sizes, increase of performance and utilization of Ethernet communication with rapidly rising transmission rates. Consequently, as one of the leaders on the telecommunication connectivity market, HARTING integrates the knowledge acquired in this market segment to develop new Device Connectivity for industrial devices.

The MicroTCA telecommunications connector, for example, is implemented as a board-to-board connector for the latest devices in the field of drive control and computer technology. The new generation of PushPull connectors is also used as a robust IP67 cable-to-board solution in both market application segments. These applications have formed a general trend of convergence in the field of device connection technology. HARTING offers more than innovative device connectors, as the connectivity provided by HARTING extends far beyond conventional connector offerings, and covers the entire range of connectors, assembled units and complete backplane solutions.

HARTING IS YOUR PARTNER IN THE DESIGN-IN PROCESS

Our field service department is your first contact partner in terms of the selection and design of the ideal connectivity solution for your device. This service is supported by HARTING's technical application support with device-specific knowledge.

HARTING also places a team of experts in the fields of RF, EMC, housing technology, mechanical strength, high-current applications and installation concepts (cabling classes) at your disposal. These capabilities allow us to simulate your applications in advance and test it in the course of development in an accredited laboratory.

The HARTING Technology Group holds all the key technologies for integrated device connectivity, such as connection technology for PCBs based on SMD, THT, THR or press-fit technology and develops connectivity solutions for international standardization in cooperation with user groups.

The latest generation of PushPull connectors was developed in cooperation with the German automotive industry and subsequently standardized on an international level.

You determine which part of the design-In process should be handled by HARTING.

There are three ways of finding the ideal device connectivity with HARTING:

1. You select the suitable device connection technology from the DeviceCon catalog and handle the design-in by yourself with the help of our technical applications support.
2. You define the scope of requirements for the device interfaces. HARTING supports you in selecting the device connection technology, with the focus always set on choosing the ideal connection technology for device integration. HARTING also holds the respective know-how for handling the entire design and the production of custom assembled units or backplanes.
3. You plan a new device generation with individualized device connectivity, which is defined in the course of a joint project. The result is a tailored, cost-effective solution for your series product and the differentiation of such products thanks to innovative device connectivity.

Whichever procedure you may prefer, you can always count on unrestricted HARTING support, as we are dedicated to ensuring convincing connectivity for each and every device you bring to the markets.



The **HARTING eCatalogue / eShop** can be found on our homepage at www.HARTING.com or at the direct link www.eCatalogue.HARTING.com.

The HARTING e-Catalogue is your platform for conveniently selecting individual products as well as configuring complete solutions. Our comprehensive product pages provide you with all necessary technical information and CAD files in various formats for downloading. You may also contact our technical sales department directly.

Find out about **product innovations and news** on the start page of the HARTING e-Catalogue or go directly to www.product-news.HARTING.com.

Registered users can take advantage of MyHARTING to check on availability or prices, and to place or track their orders. Here, your customized „HARTING history“ provides you with a list of your inquiries, quotations and more.

Sign up now for your free e-Catalogue account at HARTING!

www.eShop.HARTING.com

Product samples: Fast-track delivery to your desk, free of charge

The new free express sample service in the HARTING eCatalogue allows customers to order samples immediately, easily and completely free of charge. A broad selection from the device connectivity product portfolio is now available. If a product is unavailable, the system offers alternative products with similar features that can be requested at a mouse click.

The free samples are shipped within 24 hours at no cost to you. This service enables tremendous flexibility, especially in the design phase of projects.

General information

It is the customer's responsibility to check whether the components illustrated in this catalogue also comply with different regulations from those stated in special fields of applications.

We reserve the right to modify designs or substance of content in order to improve quality, keep pace with technological advancement or meet particular requirements in production.

No part of this catalogue may be reproduced in any form (print, photocopy, microfilm or any other process) or processed, duplicated or distributed by means of electronic systems without the prior written consent of HARTING Electronics GmbH, Espelkamp. We are bound by the German version only.



1. Han-Quick Lock® SPRING CLAMP TECHNOLOGY

The Quick Lock® radial spring clamp technology combines the benefits of a spring-loaded contact with crimp technology. The result is a simple and vibration-proof wiring technology with the crimp technology contact grid. Quick Lock® technology is suited for wiring flexible conductors. The stranded wires are split up by means of a center mandrel and are then pressed onto this mandrel by means of radial spring force. The spring is opened and activated using a standard screwdriver, which ensures convenient on-site termination, repair or service work.

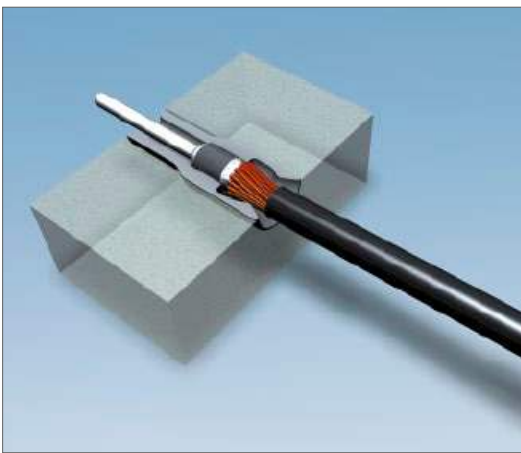

2. AXIAL SCREW TERMINALS

Flexible stranded wires inserted into axial screw terminals are split up by a center mandrel and are then pressed onto the outer wall of the contact by screwing down the mandrel. This vibration-proof connection technology is also a convenient solution for repair work and is capable of handling conductor cross-sections to 100 mm². The axial screw terminal is an ideal alternative to applications that required special crimp tools for wiring large conductor cross-sections.



3. CAGE CLAMP TERMINALS

The cage clamp terminal technology is used to terminate flexible and solid conductors by means of spring force. After the spring has been opened by an actuator element, the stripped conductor is simply inserted into the contact chamber. This connection technology requires minimum operating expense and is characterized by its high functional safety. The spring-loaded connection also allows the termination of more than one wire per contact and excels with high vibration and shock resistance.

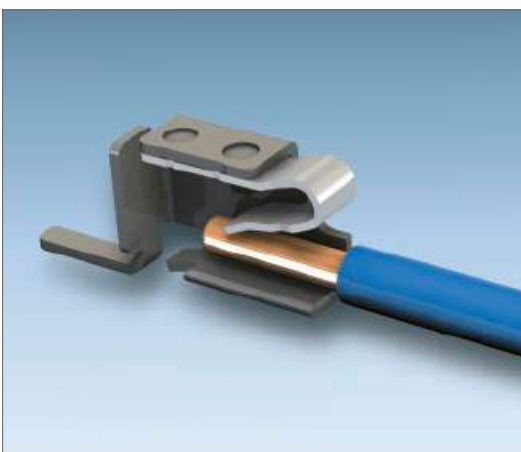

4. PUSH-IN SPRING CONNECTION

Push-in spring connector technology connects flexible and solid conductors by means of a spring. In a time-saving manner rigid conductors and flexible prefabricated conductors with wire-end ferrules can be connected directly, without the need for tools. Push-in spring connector technology ensures low insertion force and high conductor withdrawal force, and multiple connections are possible. When it comes to flexible conductor connection, before plugging in the terminal point should be opened via the activation element or with a suitable screw-driver.

5. SCREW TERMINALS

The screw terminal represents classic connection technology, with screws retaining the stripped conductors in the contact chambers. Screw technology is suited for wiring solid and flexible conductors. Screw terminals with wire protection allows the insertion of stranded wire into the contact chamber without a ferrule. Handling screw terminal technology requires nothing more than a screwdriver. The pull out forces of screw terminal technology are standardized in IEC 60 999-1.

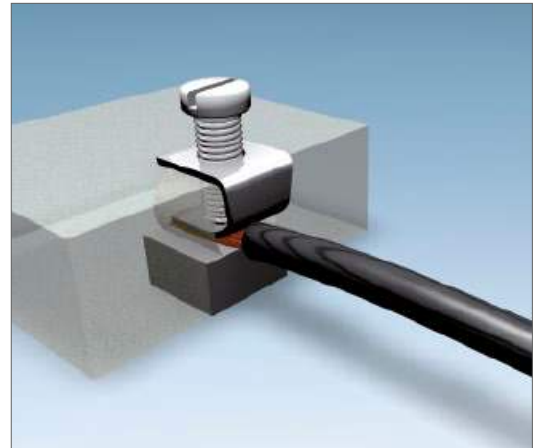

6. IDC INSULATION DISPLACEMENT TERMINALS

IDC (insulation displacement contact) technology facilitates the simple and safe termination of solid and flexible conductors. With IDC technology, a blade cuts through the wire insulation and produces an elastic termination in a single pass. This gas-proof connection provides maximum safety even for the lowest currents and voltages. *HARAX*[®] Fast termination technology is a special feature offered by HARTING which combines the insulation displacement connector with a wire guide element for conveniently producing on-site field installation without special tools. Technical requirements for IDC technology are standardized in IEC 60 352-3.



7. CRIMP TERMINALS

Gas-proof and the miniaturized contact technology are synonymous with crimp technology. The flexible conductor is inserted into the crimp contact and is retained by controlled deformation. This technology is similar to a cold welding process and provides maximum aging resistance and mechanical resistance to shock and vibration. Crimp machines facilitate the efficient, streamlined production of system cable assemblies, and crimp technology can also be deployed for field assemblies using the corresponding hand crimp tools. The technical requirements for crimp technology are standardized in IEC 60 352-2.

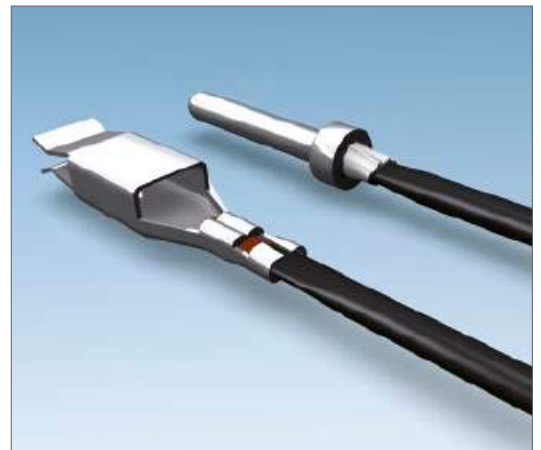

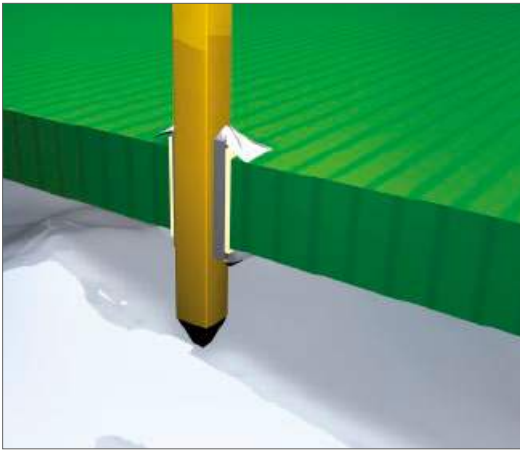

8. THT SOLDERING TECHNOLOGY

Proven over decades, standard soldering technologies deliver maximum stability and process reliability.

The soldering pins of the connectors are inserted into the through-plated PCB holes and can then be soldered simultaneously with other components in a wave soldering process.

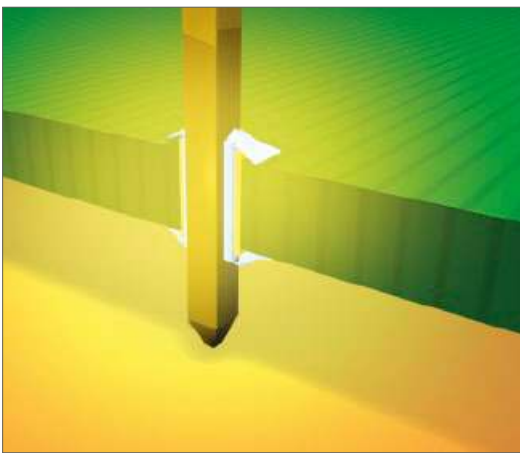

9. SMC SOLDERING TECHNOLOGY

The connector is inserted into through-plated PCB holes similar to standard component assembly for processing with SMC (Surface Mount Compatible) soldering technology. Insertion of these SMT components can be automated by means of Pick & Place assembly in preparation for a reflow soldering process together with the surface-mounted component.

This connection technology is characterized by high mechanical strength and is facilitated by a design that is specially adapted to the reflow soldering process (high-temperature materials).

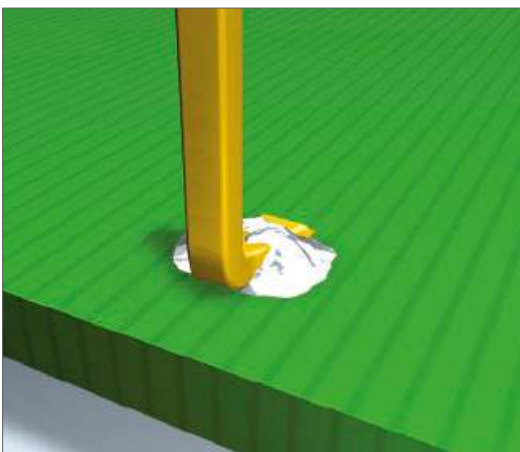

10. SMT SOLDERING TECHNOLOGY

By contrast to through-plated assembly, the SMT (Surface Mounted Technology) connectors are soldered directly onto the PCB surface by means of soldering pads. This process represents a uniform connection technology for PCB assembly and offers the advantage of SMT connectors that do not require separate wave soldering.

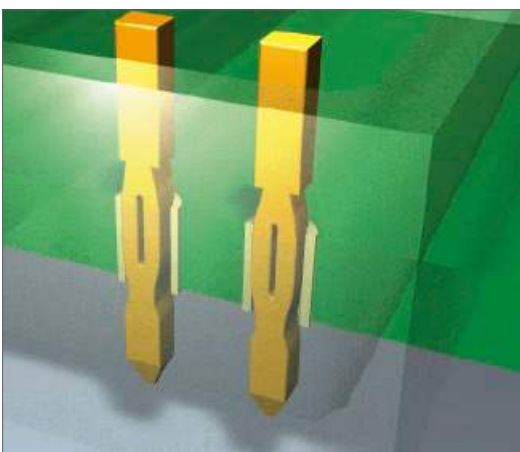

11. PRESS-IN TECHNOLOGY

This solder-free connection technology is based on press-in mounting of a pin in a through-plated PCB hole. The implementation of a state-of-the-art, flexible press-fit zone allows for the compensation of tolerances of PCB holes and meets high electrical and mechanical requirements for properties such as low press-in forces and high holding forces.

Press-in technology supports unlimited cost efficient processing, especially of pins with selective gold plating for backplane bus systems.

Grid area for notes

01. HARTING RJ Industrial® – RJ45 Ethernet Connectors

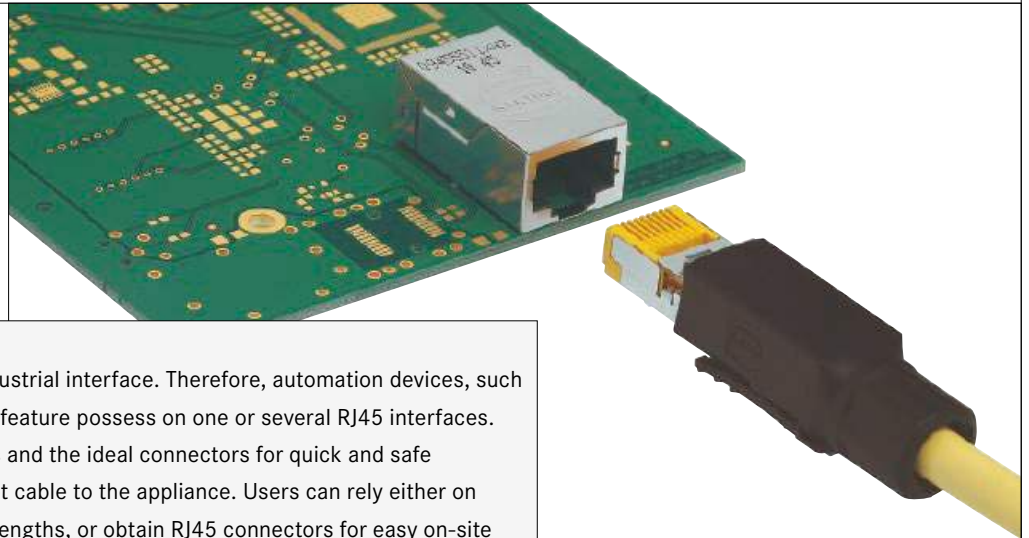

Ethernet is coming up to standard industrial interface. Therefore, automation devices, such as controllers, sensors and actuators feature possess on one or several RJ45 interfaces. HARTING offers the matching sockets and the ideal connectors for quick and safe connection of the 2- or 4-pair Ethernet cable to the appliance. Users can rely either on ready-to-use patch cables in various lengths, or obtain RJ45 connectors for easy on-site dressing of the cables without using special tools.

HARTING relies on the *HARAX*® quick connection technology for on-site preparation of cables, meeting all industrial requirements made on safe and durable contacting. The HARTING RJ Industrial® connector family also supports Ethernet automation profiles such as PROFINET, Ethernet/IP, POWERLINK and EtherCAT for the integration of RJ45 connection technology at field levels.

Application profile:

CONNECTION TYPE		ENVIRONMENT		APPLICATION							
Board to Board	Cable/Wire to Board	IP20	IP65 / IP67	Data	Signal	Power	high performance				
							Data transfer rate	Shielding	Number of contacts, contact density	Voltage, working current	
Cable termination			PCB termination			Application standard					
<i>Han-Quick Lock</i> ®	<i>IDC HARAX</i> ®	<i>Crimp</i>	<i>THT</i>	<i>SMC</i>	<i>SMT</i>	<i>PROFINET</i>	<i>EtherNet/IP</i>	<i>IEEE 802.3</i>	<i>ISO IEC 24702</i>	<i>ETHERNET POWERLINK</i>	<i>EtherCAT Technology Group</i>
<i>Screw</i>	<i>Cage clamp</i>	<i>Axial screw</i>	<i>Press-in</i>								
						Housing integration					
						<i>Separate housing</i>	<i>integrated housing</i>				

1) Piercing contacts



Contents

	Page
Introduction HARTING RJ Industrial®	01.02
HARTING RJ Industrial® RJ45 – Jacks for device integration and accessories	01.04
HARTING RJ Industrial® RJ45 – Coupler and adapter pcb's	01.09
HARTING RJ Industrial® RJ45 – Connectors, 4-poles	01.14
HARTING RJ Industrial® RJ45 Gigalink – Connectors, 8-poles	01.18
HARTING RJ Industrial® 10G	01.19
HARTING RJ Industrial® – Tools	01.20
HARTING RJ Industrial® – System cables	01.21
Ha-VIS preLink®	01.23
<i>har-port</i> – Coupler	01.36

The modular HARTING RJ Industrial® connector family is based on the standard RJ45 pin profile and was developed especially for use in rugged industrial environments.

This technology charts a new course in the wiring of appliances with Ethernet interfaces, enabling the on-site configuration of connectors for many industrial applications, no matter if the product is a power connector or a communications connector.

For the fast wiring of all Ethernet networks, HARTING relies consistently on the *HARAX*® IDC connection technology which has proved its worth in many industrial applications.

Solid or flexible conductors up to a cross-section of AWG 22 are terminated by IDC technology, without stripping or using any special tool.

For all Gigabit Ethernet networks HARTING offers the 8-pole data module with piercing connection technology and the new 8-pole data module with *HARAX*® quick termination technology.

All data modules have the same dimensions.

The replacement of the data module enables the conversion of any 100 MBit Fast Ethernet network into a Gigabit Ethernet network using HARTING RJ Industrial® connectors. This innovative platform strategy also permits the use of the RJ45 data module in combination with the PushPull, Han-Max® and Han® 3 A connector families.

Based on this data module, HARTING has developed a comprehensive connector family which covers all applications for Fast Ethernet, 1/10 Gigabit Ethernet, PROFINET, Ethernet/IP and other Ethernet profiles in the industrial environment.

Degree of protection IP20 is available for the standard RJ45 connectors, either for configuration in the field, or as molded system patch cable.

APPLIANCE INTEGRATION:

HARTING offers various RJ45 jacks for direct mounting on the PCBs of appliances.

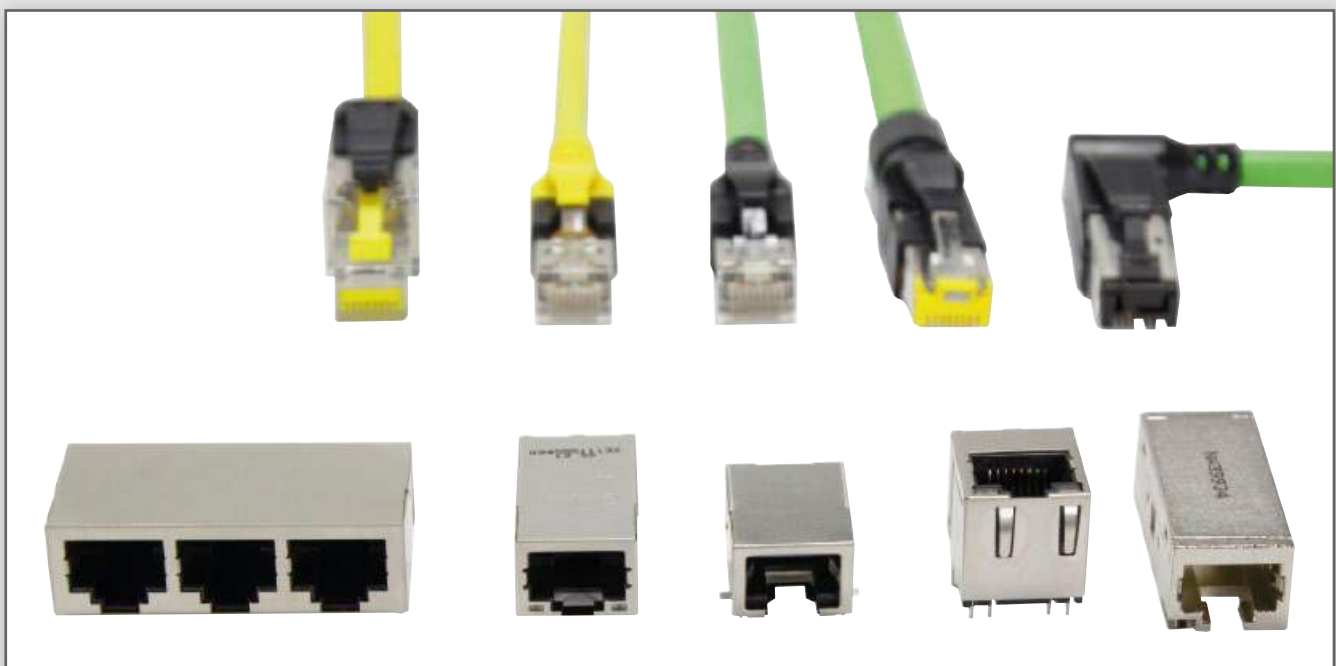

RJ45 QUICK CONNECTION WITH HARAX®:

The HARTING HARAX® quick connection technology is the ideal solution for dressing RJ45 connectors on-site. In order to produce a gas-proof and vibration resistant Ethernet connection, users only have to strip the cable insulation, insert the conductors, terminate the shielding plates and close the connector.

HARAX® is the most convenient handling standard connection for Ethernet where the emphasis is set on the assembly of connectors in the field.

HARAX® is an ideal IDC connection technology which is deployed universally in a very wide range of data, signal and power series.

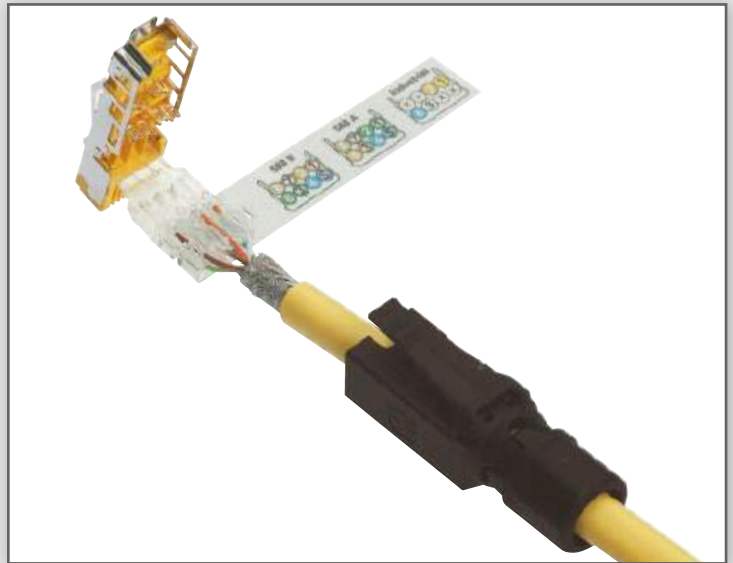

ASSEMBLED SYSTEM CABLES:

HARTING offers a comprehensive range of ready-to-use RJ45 system cables for the simple and easy connection of Ethernet devices. HARTING also provides assembled and tested system cables for special Ethernet profiles such as PROFINET and Ethernet/IP.

The range of solution comprises star quad, double-pair and four-pair cables of diverse structure, as required in drag chain applications, for example.

Consequently, HARTING system cables can be deployed in all Ethernet applications and all ambient conditions.

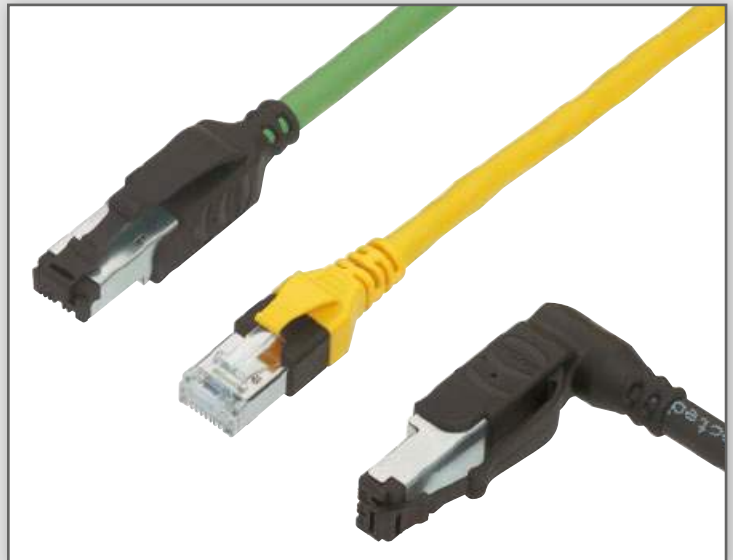

PERFORMANCE FOR THE FUTURE:

The HARTING RJ Industrial® portfolio offers a wide range of solutions for Industrial Ethernet, independent of wiring strategies to ISO/IEC 11801 currently deployed to wire appliances.

HARTING RJ Industrial® provides field connection technology based on 2-pair category 5 variant and on 4-pair category 6 variant.

HARTING RJ Industrial® is ideal for the future-proof planning of appliance interfaces, regardless of whether your future applications will involve Fast or Gigabit Ethernet, or 10 Gigabit Ethernet.





HARTING RJ Industrial® RJ45 jacks for direct device integration

Advantages

- Compact design
- Category of transmission Cat. 5
- Suitable for PoE (IEEE 802.3af) and PoE+ (IEEE 802.3at)
- Temperature range -40 °C ... +70 °C

Technical characteristics

Locking	RJ45 acc. to IEC 60603-7
Number of contacts	8
Degree of protection	IP20
Rated voltage	125 V AC
Rated current	1.5 A
Mating face	RJ45 acc. to IEC 60603-7
Mating cycles	min. 750
	UL approval

Identification	Part number	Drawing	Dimensions in mm
----------------	-------------	---------	------------------

Components device side

RJ45 jack (low profile)

Solder variant SMD,
90° angled

09 45 551 1100¹⁾
09 45 551 1110²⁾

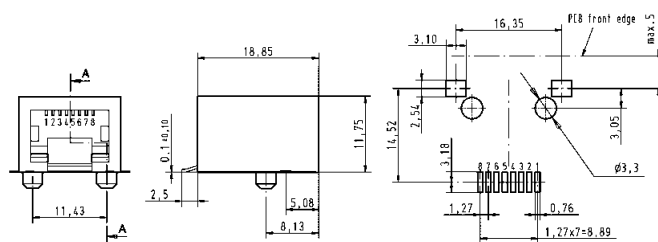

Solder variant THT,
90° angled
with EMC contacts

09 45 551 1101¹⁾

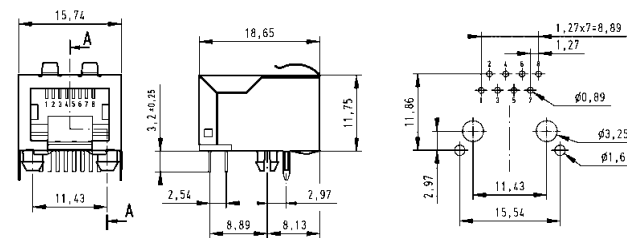

Solder variant THT,
90° angled

09 45 551 1102¹⁾

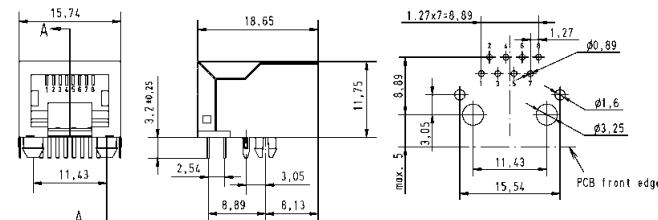

Solder variant THT,
vertical

09 45 551 1103³⁾

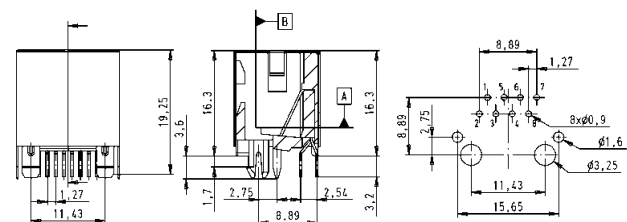

1) Packaging: Blister à 120 pieces
2) Packaging: Tape & Reel à 130 pieces
2) Packaging: Blister à 80 pieces



HARTING RJ Industrial® RJ45 jacks for direct device integration

Advantages

- Compact design
- Category of transmission Cat. 6
- Suitable for PoE (IEEE 802.3af) and PoE+ (IEEE 802.3at)
- Temperature range -40 °C ... +85 °C

Technical characteristics

Locking	RJ45 acc. to IEC 60603-7
Number of contacts	8
Degree of protection	IP20
Rated voltage	125 V AC
Rated current	1.5 A
Mating face	RJ45 acc. to IEC 60603-7
Mating cycles	min. 750
Temperature range	-40 °C ... +85 °C
	UL approval

Identification	Part number	Drawing	Dimensions in mm
----------------	-------------	---------	------------------

Components device side

RJ45 jack (Standard)

Solder variant overmoulded (THT),
90° angled

09 35 002 2101¹⁾

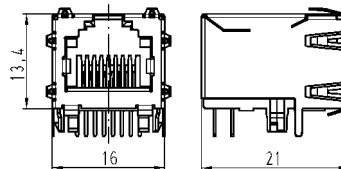

Solder variant overmoulded (THT),
180° straight

09 35 002 2102²⁾

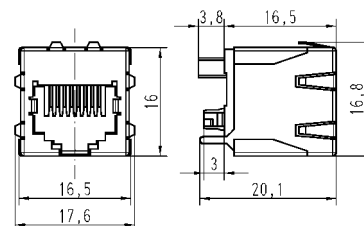

PCB layout, component side

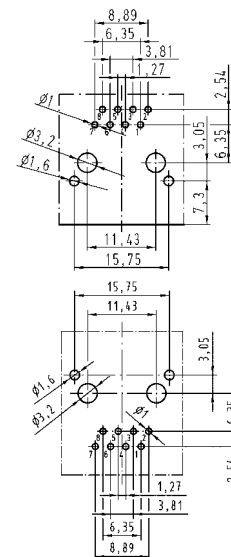

1) Packaging: Blister à 360 pieces
2) Packaging: Blister à 400 pieces



HARTING RJ Industrial® RJ45 jacks for direct device integration

Advantages

- Compact design
- Excellent EMC behaviour due to integrated transformers and filters for 10/100 Mbit or 1 Gbit Ethernet
- Versions from 10/100 Mbit up to 10 Gbit Ethernet resp. Cat. 5

Technical characteristics

Mating face	RJ45 acc. to IEC 60603-7
Number of contacts	8
Degree of protection	IP20
Mating cycles	min. 750
Temperature range	-40 °C ... +85 °C

Identification	Part number	Drawing	Dimensions in mm
----------------	-------------	---------	------------------

Components device side

RJ45 jack Cat. 5

with bicolour LED

09 45 551 1119

without LED

09 45 551 1120

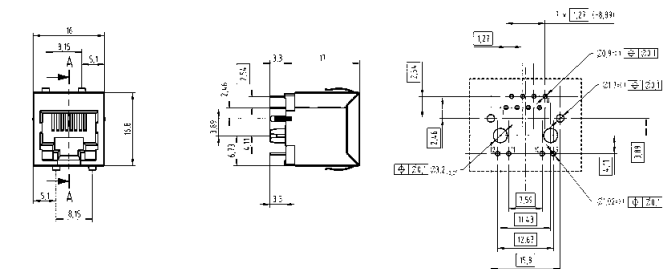

RJ45 jack with transformer

10/100 Mbit with bicolour LED

09 45 551 1140

10/100 Mbit with LED green/yellow

09 45 551 1142

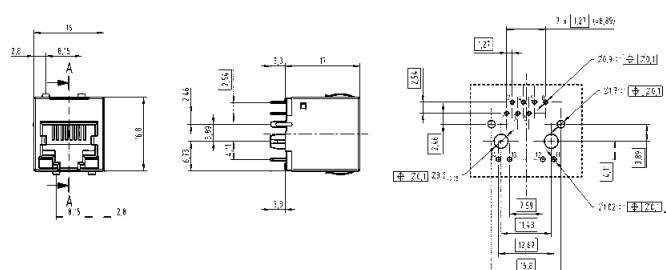

1 Gbit with bicolour LED

09 45 551 1141

1 Gbit with LED green/yellow

09 45 551 1143

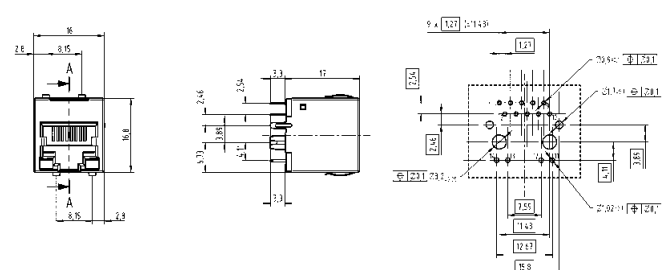



HARTING RJ Industrial® RJ45 jacks with transformer

Advantages

- Compact design
- Integrated optical fibres
- Excellent EMC behaviour due to integrated transformers and filters for 10/100 Mbit or 1 Gbit Ethernet
- SMC compatible
- Versions from 10/100 Mbit up to 10 Gbit Ethernet and PoE
- Usable for IP65 / IP67 device integration with HARTING PushPull and Han® 3 A RJ45

Technical characteristics

Mating face	RJ45 acc. to IEC 60603-7
Number of contacts	8
Degree of protection	IP20
Rated voltage	30 V DC
Rated current	8 mA DC
Mating cycles	min. 750
Temperature range	-25 °C ... +70 °C

Identification	Part number	Drawing	Dimensions in mm
----------------	-------------	---------	------------------

Components device side

RJ45 jack with transformer (low profile)

90° angled, THT
10/100 Mbit Ethernet

Schematic:

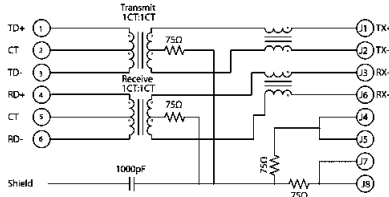

10/100 Mbit Ethernet and PoE

09 45 551 1130¹⁾

90° angled, THT
1 Gbit Ethernet

Schematic:

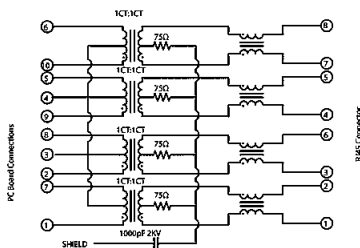

1 Gbit Ethernet and PoE

09 45 551 1131¹⁾

09 45 551 1530¹⁾

09 45 551 1531¹⁾

90° angled, THT
10 Gbit Ethernet

09 45 551 1560¹⁾

Customer specific versions on request

¹⁾ Packaging: Blister à 56 pieces

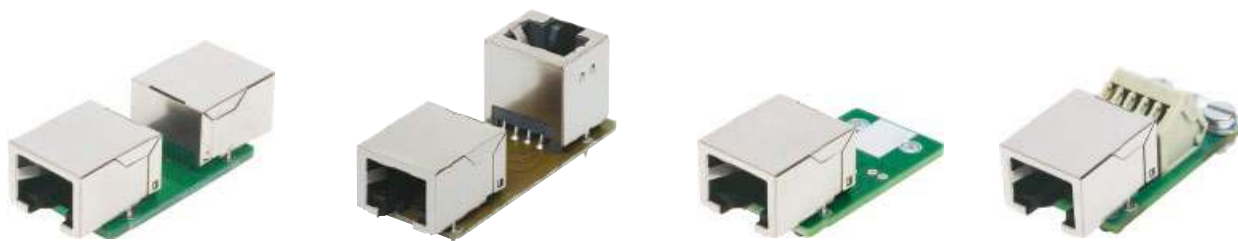

HARTING RJ Industrial® RJ45 – coupler and adapter PCB's

Advantages

- Compatible with Han® 3 A¹⁾ and HARTING PushPull
- Suitable for PoE (IEEE 802.3af) and PoE+ (IEEE 802.3at)
- Temperature range -40 °C ... +70 °C

Technical characteristics

Rated voltage	125 V AC
Rated current	1.5 A
Mating face	RJ45 acc. to IEC 60603-7
Mating cycles	min. 750

Identification	Part number	Drawing	Dimensions in mm
----------------	-------------	---------	------------------

Coupler PCB 2x RJ45 8-poles

2 x RJ45 jack
(09 45 551 1102)

09 45 545 1130

1 x RJ45 jack horizontal
(09 45 551 1102) and
1 x RJ45 jack vertical
(09 45 551 1103)

09 45 545 1138

Adapter PCB 1x RJ45 8-poles to solder points

to solder points

09 45 545 1134

Adapter PCB 1x RJ45 8-poles cage clamp, 5-pole, 1.5 mm²

cage clamp, 5-pole, 1.5 mm²

09 45 545 1135

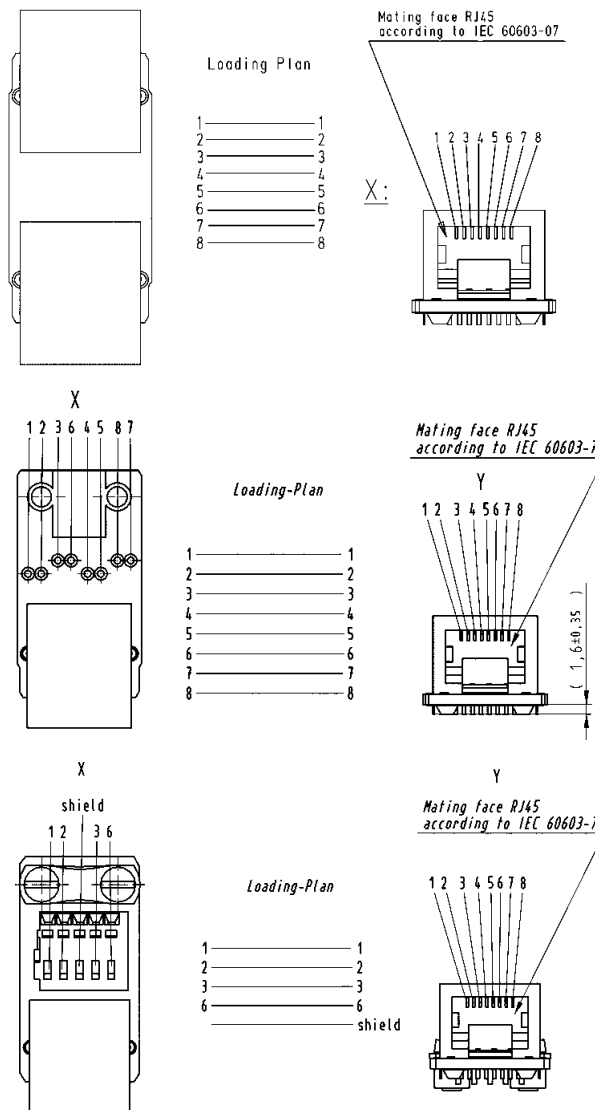

¹⁾ with suitable adapter, see page 04.04

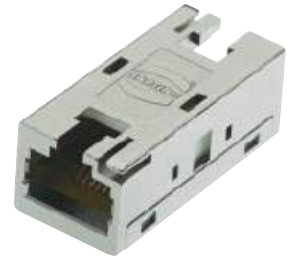

HARTING RJ Industrial® 10G RJ45 bulkhead

Advantages

- Compact and robust design
- 360° shielding
- Compatible with HIFF dimensions for use in:
 - Han® 3 A series
 - HARTING PushPull (V4)
 - Han® PushPull (V14)
 - *har*-port
 Details see page 01.11
- Suitable for PoE (IEEE 802.3af) and PoE+ (IEEE 802.3at)

Technical characteristics

Mating face	RJ45 acc. to IEC 60603-7
Number of contacts	8
Transmission category	Cat. 6, performance class E _A , suitable for 1/10 Gigabit Ethernet
Degree of protection	IP20
Mating cycles	min. 750
Temperature range	–40 °C ... +70 °C
Housing material	Zinc die-cast, nickel-plated
Flammability acc. to UL 94	V0

Identification	Part number	Drawing	Dimensions in mm
----------------	-------------	---------	------------------

HARTING RJ Industrial® 10G RJ45 bulkhead (HIFF version)

09 45 545 1560

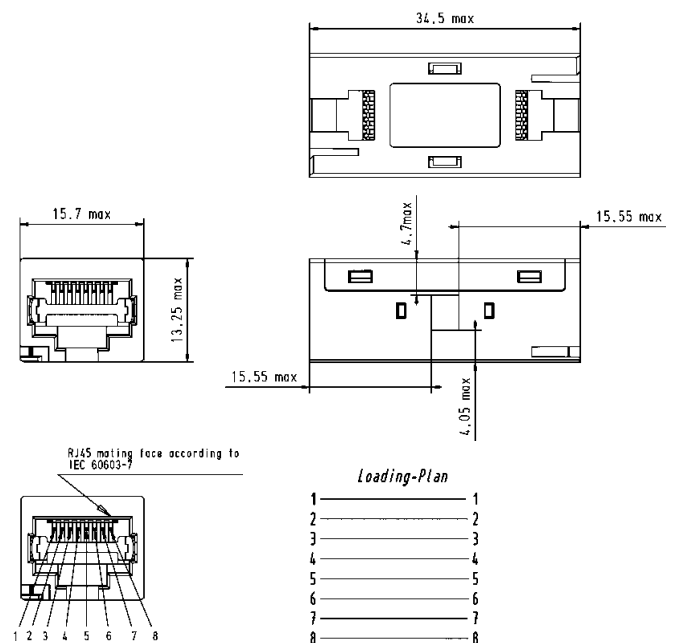

HARTING RJ Industrial® 10G RJ45 bulkhead (keystone version)

09 45 545 1568

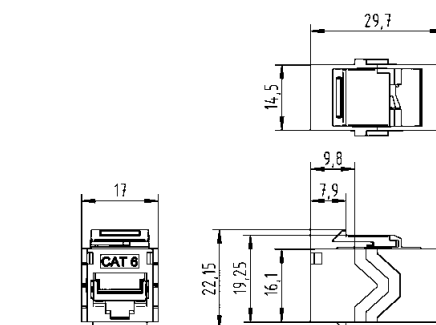



HARTING RJ Industrial® cable jack (HIFF version)

Advantages

- Compact and robust design
- 360° shielding
- Category of transmission Cat. 6
- Suitable for solid and stranded wires
- Field-assembly with *HARAX*® quick termination in IDC technology
- Compatible with HIFF dimensions for use in:
 - Han® 3 A series with HIFF adapter 09 45 515 0024
 - HARTING PushPull (V4)
 - Compact bulkhead mounting housing 09 45 545 0028
 - EasyInstall bulkhead mounting housing 09 45 545 0032
 - Han® PushPull (V14)
 - Panel feed-through plastic 09 35 012 0331
 - Panel feed-through metal rectangular 09 35 012 0311
 - Panel feed-through metal circular 09 35 012 0312
 - *har*-port 09 45 452 0000
- Suitable for PoE (IEEE 802.3af) and PoE+ (IEEE 802.3at)

Technical characteristics

Connector type	RJ45 connector acc. to IEC 60603-7
Number of contacts	8
Transmission category	Category 6, class E _A , suitable for 1/10 Gigabit Ethernet
Transmission performance	Category 6 / Class E _A up to 500 MHz acc. to ISO/IEC 11801:2002, EN 50173-1
Transmission rate	10/100 Mbit/s and 1/10 Gbit/s
Shielding	fully shielded, 360° shielding contact
Mounting	Field-assembly
Cable termination	with IDC-contacts, without tools
Connectable cables	
- Conductor cross section	AWG 27 ... AWG 24 (solid/stranded) ¹⁾
- Conductor diameter	AWG 24 ... AWG 22 (solid/stranded) ²⁾
- Cable diameter	max. 1.6 mm (incl. insulation) 5 ... 9 mm
Mating cycles	min. 750
Degree of protection	IP20
Temperature range	-40 °C ... +70 °C
Housing material	Zinc die-cast, nickel-plated

Identification	Part number	Drawing	Dimensions in mm
HARTING RJ Industrial® 10G cable jack, 8-poles			
AWG 28 ... 24	09 45 545 1561		
AWG 24 ... 22	09 45 545 1562		
HARTING RJ Industrial® PN cable jack, 4-poles, Cat. 5			
AWG 24 ... 22	09 45 545 1120		
Unlocking tool for opening of the HARTING RJ Industrial® cable jacks	20 82 000 9916		

¹⁾ For part number 09 45 545 1561

²⁾ For part number 09 45 545 1562 and 09 45 545 1120

HARTING RJ Industrial® cable jack (keystone version)



Advantages

- Compact and robust design
- 360° shielding
- Category of transmission Cat. 6A
- Suitable for solid and stranded wires
- Field-assembly with *HARAX*® quick termination in IDC technology
- Keystone form factor – usable for DIN-rail outlet 09 45 851 0000 and a wide range of typical patch panels and wall outlets
- Suitable for PoE (IEEE 802.3af) and PoE+ (IEEE 802.3at)

Technical characteristics

Connector type	RJ45 connector acc. to IEC 60 603-7
Number of contacts	8
Transmission category	Category 6A, class EA, suitable for 1/10 Gigabit Ethernet
Transmission performance	Category 6A / Class EA up to 500 MHz acc. to ISO/IEC 11 801:2002, EN 50 173-1
Transmission rate	10/100 Mbit/s and 1/10 Gbit/s
Shielding	fully shielded, 360° shielding contact
Mounting	Field-assembly
Cable termination	with IDC-contacts, without tools
Connectable cables	
- Conductor cross section	AWG 27 ... AWG 24 (solid/stranded) ¹⁾ AWG 24 ... AWG 22 (solid/stranded) ²⁾
- Conductor diameter	max. 1.6 mm (incl. insulation) ¹⁾ max. 1.2 mm (incl. insulation) ²⁾
- Cable diameter	5 ... 9 mm
Mating cycles	min. 750
Degree of protection	IP 20
Temperature range	-40 °C ... +70 °C
Housing material	Zinc die-cast, nickel-plated

Identification	Part number	Drawing	Dimensions in mm
HARTING RJ Industrial® 10G cable jack, 8-poles			
AWG 28 ... 24	09 45 545 1563		
AWG 24 ... 22	09 45 545 1564		
HARTING RJ Industrial® PN cable jack, 4-poles, Cat. 5			
AWG 24 ... 22	09 45 545 1122		
Unlocking tool for opening of the HARTING RJ Industrial® cable jacks	20 82 000 9916		

¹⁾ For part number 09 45 545 1564

²⁾ For part number 09 45 545 1563 and 09 45 545 1122

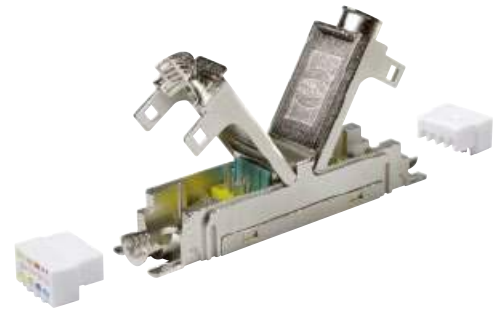

HARTING RJ Industrial® 10G Extender

Advantages

- Simple, fast and reliable connection of data cables
- Compact and robust design
- 360° shielding
- Category of transmission Cat. 6_A
- Suitable for solid and stranded wires
- Field assembly without special tools

Application

- Extension of cables for data communication
- Connection of cables with different cross-sections
- Linking of fire compartments

Technical characteristics

Connector type	RJ45 connector acc. to IEC 60 603-7
Number of contacts	8
Transmission category	Category 6 _A , Class E _A , suitable for 1/10 Gigabit Ethernet
Transmission performance	Category 6 _A / Class E _A up to 500 MHz acc. to ISO/IEC 11 801:2002, EN 50 173-1
Transmission rate	10/100 Mbit/s and 1/10 Gbit/s
Shielding	fully shielded, 360° shielding contact
Mounting	IDC termination
Connectable cables	
– Conductor cross section	AWG 23 ... AWG 22 (solid and stranded)
– Conductor diameter	1.3 ... 1.6 mm
Cable diameter	5 ... 9 mm
Degree of protection	IP20
Temperature range	-40 °C ... +70 °C
Housing material	Zinc die-cast, nickel-plated

Identification

Part number

Drawing

Dimensions in mm

HARTING RJ Industrial®
10G Extender

09 45 545 1569

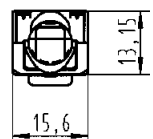
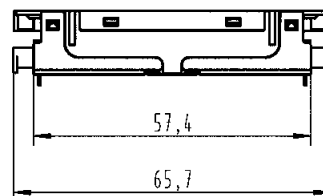



HARTING RJ Industrial® connector set RJ45, 4-poles

Advantages

- RJ45 Ethernet-Data connector suitable for industry
- Tool-less field-assembly with *HARAX*® rapid termination in IDC technology
- Compact design
- Ergonomical unlocking clip
- Less weight assures shock- and vibration-resisting connection
- Category of transmission Cat. 5
- Suitable for termination of solid and stranded cables
- Up to 10 x reconductable
- PROFINET compatible
- Suitable for PoE (IEEE 802.3af) and PoE+ (IEEE 802.3at)

Technical characteristics

Connector type	RJ45 connector acc. to IEC 60 603-7
Number of contacts	4
Transmission performance	Category 5 / Class D up to 100 MHz acc. to ISO/IEC 11 801:2002, EN 50 173-1
Transmission rate	10/100 Mbit/s
Mounting	field-assembly
Cable termination	with IDC-contacts, without tools
Connectable cables	
- Conductor cross section	AWG 24/7 ... AWG 22/7 (stranded) AWG 23/1 ... AWG 22/1 (solid) AWG 26/7 (09 45 151 1109)
- Conductor diameter	max. 1.6 mm (09 45 151 1100 / 09 45 151 1108) max. 1.2 mm (09 45 151 1109)
- Cable diameter	6.1 ... 6.9 mm
Mating cycles	min. 750
Degree of protection	IP20
Temperature range	-40 °C ... +70 °C
Housing material	Polyamide, UL 94-V0
Colour	black
	UL approval (E102079)

Identification	Part number	Drawing	Dimensions in mm
----------------	-------------	---------	------------------

HARTING RJ Industrial® connector set RJ45, 4-poles

incl.:
housing with shielding,
splicing element, cable gland
and instruction manual

like 09 45 151 1100
but for AWG 26

09 45 151 1100
09 45 151 1108¹⁾

09 45 151 1109

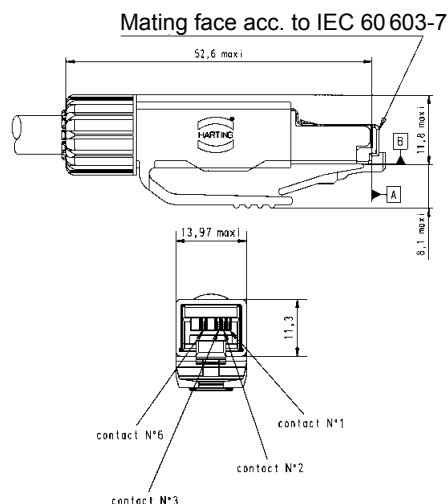

¹⁾ Packaging with 100 sets

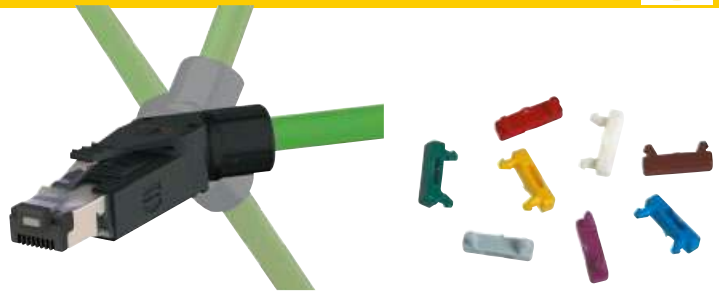

HARTING RJ Industrial® PN connector set RJ45, 4-poles

Advantages

- RJ45 Ethernet-Data connector suitable for industry
- Field-assembly with *HARAX*® quick termination in IDC technology
- Compact design
- Ergonomically unlocking clip
- Less weight assures shock- and vibration resisting connection
- Category of transmission Cat. 5
- Suitable for solid and stranded wires
- Suitable for PoE (IEEE 802.3af) and PoE+ (IEEE 802.3at)

Technical characteristics

Connector type	RJ45 connector acc. to IEC 60603-7
Number of contacts	4
Transmission category	Category 5, class D
Transmission performance	Category 5 / Class D up to 100 MHz acc. to ISO/IEC 11801:2002, EN 50 173-1
Transmission rate	10/100 Mbit/s
Shielding	fully shielded, 360° shielding contact
Mounting	Field-assembly
Cable termination	with IDC-contacts, without tools
Connectable cables	
- Conductor cross section	AWG 27 ... AWG 22 (solid / stranded)
- Conductor diameter	max. 1.6 mm (incl. insulation)
- Cable diameter	4.5 ... 9 mm (straight version) 4.5 up to 8 mm (45° angled version)
Mating cycles	min. 750
Degree of protection	IP20
Temperature range	-40 °C ... +70 °C
Housing material	Polyamide, UL 94-V0
Colour	black

Identification	Part number	Drawing	Dimensions in mm
HARTING RJ Industrial® PN connector set RJ45, 4-poles			
straight version	09 45 151 1120		
45° angled version (four different cable outlets possible)	09 45 151 1121		

Identification	Colour	Part number
Colour clips for colour coding the HARTING RJ Industrial® PN connector If required the colour clips can be equipped with an RFID-chip for automatic patch cable-ID recognition and storage.	White	09 45 850 0001
	Grey	09 45 850 0002
	Yellow	09 45 850 0003
	Magenta	09 45 850 0005
	Red	09 45 850 0007
	Blue	09 45 850 0008
	Green	09 45 850 0009
	Brown	09 45 850 0010

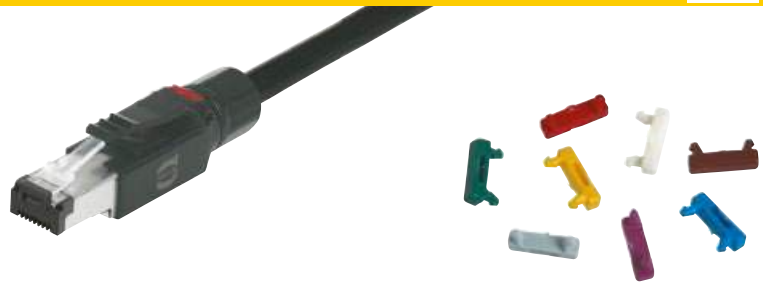

HARTING RJ Industrial® EtherRail® RJ45 connector set, 4-poles

Advantages

- RJ45 Ethernet-Data connector suitable for industry
- Field-assembly with *HARAX*® quick termination in IDC technology
- Compact design
- Ergonomically unlocking clip
- Less weight assures shock- and vibration resisting connection
- Category of transmission Cat. 5
- Suitable for solid and stranded wires
- Suitable for PoE (IEEE 802.3af) and PoE+ (IEEE 802.3at)
- Optimized version for Ha-VIS EtherRail® Ethernet cable, Shielded Star Quad Cable, AWG 22/19 ultra-flexible, according Cat. 5 cabling standard (ISO/IEC 11 801), part numbers 09 45 600 0188, 09 45 600 0138, 09 45 600 0148 and 09 45 600 0158

Technical characteristics

Connector type	RJ45 connector acc. to IEC 60 603-7
Number of contacts	4
Transmission category	Category 5, class D
Transmission performance	Category 5 / Class D up to 100 MHz acc. to ISO/IEC 11 801:2002, EN 50 173-1
Transmission rate	10/100 Mbit/s
Shielding	fully shielded, 360° shielding contact
Mounting	Field-assembly
Cable termination	with IDC-contacts, without tools
Connectable cables	
- Conductor cross section	AWG 27 ... AWG 22 (solid / stranded)
- Conductor diameter	max. 2 mm (incl. insulation)
- Cable diameter	4.5 ... 9 mm
Mating cycles	min. 750
Degree of protection	IP20
Temperature range	-40 °C ... +70 °C
Housing material	Polyamide, UL 94-V0
Colour	black

Identification	Part number	Drawing	Dimensions in mm
HARTING RJ Industrial® EtherRail® RJ45 connector set, 4-poles straight version	09 45 151 1122		

Identification	Colour	Part number
Colour clips for colour coding the HARTING RJ Industrial® EtherRail® RJ45 connector If required the colour clips can be equipped with an RFID-chip for automatic patch cable-ID recognition and storage.	White	09 45 850 0001
	Grey	09 45 850 0002
	Yellow	09 45 850 0003
	Magenta	09 45 850 0005
	Red	09 45 850 0007
	Blue	09 45 850 0008
	Green	09 45 850 0009
	Brown	09 45 850 0010



HARTING RJ Industrial® PN Compact connector set, 4-poles

Advantages

- RJ45 Ethernet-Data connector suitable for industry
- Field-assembly with piercing contacts
- Compact design
- Less weight assures shock- and vibration resisting connection
- Category of transmission Cat. 5
- Suitable for PoE (IEEE 802.3af) and PoE+ (IEEE 802.3at)

Technical characteristics

Connector type	RJ45 connector acc. to IEC 60 603-7
Number of contacts	4
Transmission performance	Category 5 / Class D up to 100 MHz acc. to ISO/IEC 11 801:2002, EN 50 173-1
Transmission rate	10/100 Mbit/s
Shielding	fully shielded, 360° shielding contact
Mounting	Field-assembly
Cable termination	with piercing contacts
Connectable cables	
- Conductor cross section	AWG 24/7 ... AWG 22/7 (stranded)
- Conductor diameter	max. 1.6 mm (incl. insulation)
- Cable diameter	4.5 ... 7.5 mm
Mating cycles	min. 750
Degree of protection	IP20
Temperature range	-40 °C ... +70 °C
Housing material	PA, UL 94-V0
Colour	green
	UL approval (E102079)

Identification	Part number	Drawing	Dimensions in mm
----------------	-------------	---------	------------------

HARTING RJ Industrial®
PN Compact connector set,
4-poles

Compact version

09 45 151 1130¹⁾

Assembly tool

09 45 800 0530

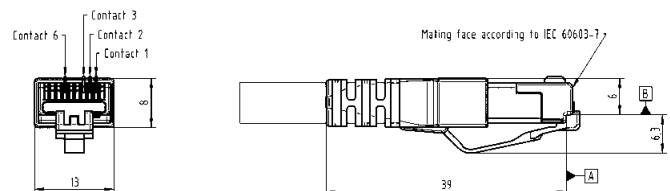

¹⁾ Packaging with 100 sets



HARTING RJ Industrial® connector set RJ45, 8-poles

Advantages

- RJ45 Ethernet-Data connector suitable for industry
- Field-assembly with piercing contacts
- Compact design
- Ergonomically unlocking clip
- Less weight assures shock- and vibration resisting connection
- Category of transmission Cat. 6_A
- Suitable for PoE (IEEE 802.3af) and PoE+ (IEEE 802.3at)

Technical characteristics

Connector type	RJ45 connector acc. to IEC 60603-7
Number of contacts	8
Transmission performance	Category 6 _A / Class E _A up to 500 MHz acc. to ISO/IEC 11801:2002, EN 50173-1
Transmission rate	10/100 Mbit/s and 1/10 Gbit/s
Shielding	fully shielded, 360° shielding contact
Mounting	Field-assembly
Cable termination	with piercing contacts
Connectable cables	
- Conductor cross section	AWG 28/7 ... AWG 24/7 (stranded)
- Conductor diameter	max. 1.05 mm (incl. insulation)
- Cable diameter	6.1 ... 6.9 mm
Mating cycles	min. 750
Degree of protection	IP20
Temperature range	-40 °C ... +70 °C
Housing material	Polycarbonate, UL 94-V0
Colour	black
	UL approval (E102079)



Identification	Part number	Drawing	Dimensions in mm
HARTING RJ Industrial® connector set RJ45, 8-poles incl.: housing with shielding, cable gland and instruction manual	09 45 151 1520 09 45 151 1520 XL ¹⁾		
Assembly tool for 09 45 151 1520	09 45 800 0520		
Compact version	09 45 151 1525 ¹⁾		
Assembly tool for 09 45 151 1525	09 45 800 0025		

¹⁾ Packaging with 100 sets



HARTING RJ Industrial® 10G connector set RJ45, 8-poles

Advantages

- RJ45 Ethernet-Data connector suitable for industry
- Field-assembly with *HARAX*® quick termination in IDC technology
- Compact design
- Ergonomically unlocking clip
- Less weight assures shock- and vibration resisting connection
- Category of transmission Cat. 6
- Suitable for solid and stranded wires
- Suitable for PoE (IEEE 802.3af) and PoE+ (IEEE 802.3at)





Technical characteristics

Connector type	RJ45 connector acc. to IEC 60603-7
Number of contacts	8
Transmission category	Category 6, class E _A , suitable for 1/10 Gigabit Ethernet
Transmission performance	Category 6 / Class E _A up to 500 MHz acc. to ISO/IEC 11801:2002, EN 50173-1
Transmission rate	10/100 Mbit/s and 1/10 Gbit/s
Shielding	fully shielded, 360° shielding contact
Mounting	Field-assembly
Cable termination	with IDC-contacts, without tools
Connectable cables	
- Conductor cross section	AWG 27 ... AWG 22 (solid / stranded)
- Conductor diameter	max. 1.6 mm (incl. insulation)
- Cable diameter	4.5 ... 9 mm (straight version) 4.5 up to 8 mm (45° angled version)
Mating cycles	min. 750
Degree of protection	IP20
Temperature range	-40 °C ... +70 °C
Housing material	Polyamide, UL 94-V0
Colour	black

Identification	Part number	Drawing	Dimensions in mm
HARTING RJ Industrial® 10G connector set RJ45, 8-poles			
straight version	09 45 151 1560 09 45 151 1560 XL ¹⁾		
45° angled version (four different cable outlets possible)	09 45 151 1561		

Identification	Colour	Part number
Colour clips for colour coding the HARTING RJ Industrial® 10G connector If required the colour clips can be equipped with an RFID-chip for automatic patch cable-ID recognition and storage.	White	09 45 850 0001
	Grey	09 45 850 0002
	Yellow	09 45 850 0003
	Magenta	09 45 850 0005
	Red	09 45 850 0007
	Blue	09 45 850 0008
	Green	09 45 850 0009
	Brown	09 45 850 0010

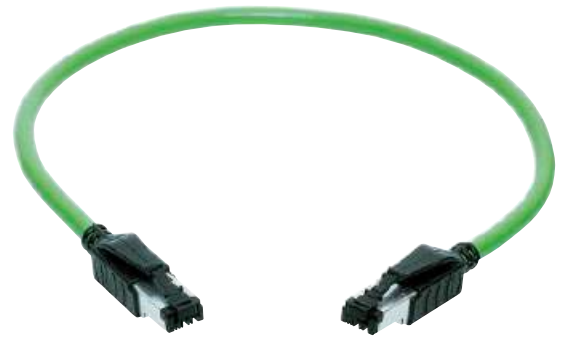

¹⁾ Packaging with 100 sets

Identification	Part number	
<p>HARTING RJ Industrial® Stripping Tool Stripping tool for Ethernet cables including blade cassette</p> <p>Spare blade cassette</p>	<p>09 45 800 0000</p> <p>09 45 800 0001</p>	 <p>The RJ Industrial Stripping Tool is ready to remove insulation from cables for fast mounting with diameters from 2.5 to 8 mm quick and easy. It allows to remove cable sheath and shielding braid in one.</p>
<p>Stripping tool</p>	<p>09 45 800 0002</p>	
<p>HARTING RJ Industrial® Gigalink Mounting tools for HARTING RJ Industrial® Gigalink connectors</p> <p>for HARTING RJ Industrial® Gigalink Cat. 6_A compact connectors</p>	<p>09 45 800 0520</p> <p>09 45 800 0025</p>	 <p>With the RJ Industrial Gigalink Assembly Tool Ethernet connectors can be quickly, easily and reliably connected to flexible cables.</p>
<p>Wire cutter</p>	<p>09 45 800 0005</p>	
<p>Cable shear</p>	<p>09 45 800 0004</p>	



RJ45
RJ Industrial

HARTING RJ Industrial® system cable RJ45, 4-wire, IP20 RJ45 patch cords for switch cabinet or PLC

Description	Part number		Technical characteristics
	Standard	Multiport	
<p>For the cabling of Industrial Ethernet networks (for example in accordance with the PROFINET guideline), based on RJ45 connectors.</p> <p>Wiring: Contacts RJ45 1/2 and 3/6</p>			<p>Transmission properties in accordance with ISO/IEC 11 801:2002: Class D</p> <p>Mating face: 2 x RJ45 in acc. with IEC 60 603-7</p> <p>Protection level: IP20 (if mated)</p> <p>Temperature range -40 °C ... +70 °C</p> <p>Electrical characteristics at 20 °C</p> <p>Contact resistance: ≤ 20 mΩ</p> <p>Insulation resistance: ≥ 500 MΩ</p> <p>Dielectric withstanding voltage: contact - contact 1 kV contact - ground 1.5 kV</p> <p>Electrical characteristics after damp heat cycles</p> <p>Contact resistance: ≤ 20 mΩ</p> <p>Insulation resistance: ≥ 100 MΩ</p> <p>Dielectric withstanding voltage: contact - contact 1 kV contact - ground 1.5 kV</p>
<p>HARTING RJ Industrial® system cable RJ45, 4-wire Type A</p>  <p>Length 1.5 m Length 3.0 m Length 5.0 m Length 10.0 m Length 20.0 m</p>	<p>09 45 771 0023 09 45 771 0025 09 45 771 0027 09 45 771 0051 09 45 771 0053</p>	<p>09 47 343 4006 09 47 343 4009 09 47 343 4012 09 47 343 4018 09 47 343 4020</p>	<p>Cable type: Industrial Ethernet Standard Cable, 2 x 2 x AWG 22/1, double shielding (PROFINET Typ A)</p> <p>Sheath: PVC green, Ø 6.5 mm</p> <p>Connectors: 2 x HARTING RJ Industrial® IP20 Data with overmolded housings</p>
<p>HARTING RJ Industrial® system cable RJ45, 4-wire Type B</p>  <p>Length 1.5 m Length 3.0 m Length 5.0 m Length 10.0 m Length 20.0 m</p>	<p>09 45 771 1123 09 45 771 1125 09 45 771 1127 09 45 771 1151 09 45 771 1153</p>	<p>09 47 343 4034 09 47 343 4037 09 47 343 4040 09 47 343 4046 09 47 343 4048</p>	<p>Cable type: Industrial Ethernet Stranded Cable, 2 x 2 x AWG 22/7, double shielding (PROFINET Typ B)</p> <p>Sheath: PVC green, Ø 6.5 mm</p> <p>Connectors: 2 x HARTING RJ Industrial® IP20 Data with overmolded housings</p>
<p>HARTING RJ Industrial® system cable RJ45, 4-wire Type C</p>  <p>Length 1.5 m Length 3.0 m Length 5.0 m Length 10.0 m Length 20.0 m</p>	<p>09 45 771 1164 09 45 771 1166 09 45 771 1168 09 45 771 1173 09 45 771 1175</p>	<p>09 47 343 4090 09 47 343 4093 09 47 343 4096 09 47 343 4102 09 47 343 4104</p>	<p>Cable type: Industrial Ethernet Trailing Cable, 2 x 2 x AWG 22/7, double shielding (PROFINET Typ C)</p> <p>Sheath: PUR green, Ø 6.5 mm</p> <p>Connectors: 2 x HARTING RJ Industrial® IP20 Data with overmolded housings</p>

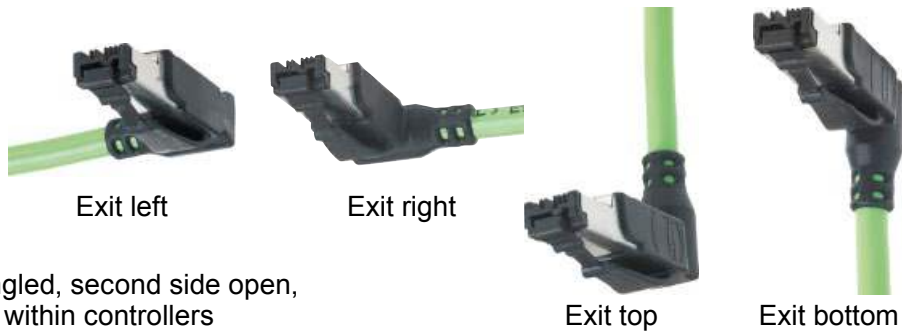

HARTING RJ Industrial® system cable RJ45 angled, 4-wire, IP20

RJ45 connection cable, first end angled, second side open, for control or distributor cabinets or within controllers

Identification	Part number				
	angled left	angled right	angled top	angled bottom	
HARTING RJ Industrial® System cable RJ45 angled, 4-wire one side pre-assembled, second side open Cable type A, green 2 x 2 x AWG 22/1	Length 0.5 m Length 1.0 m Length 1.5 m Length 2.0 m Length 3.0 m Length 5.0 m	09 47 050 0001 09 47 050 0002 09 47 050 0003 09 47 050 0004 09 47 050 0005 09 47 050 0007	09 47 060 0001 09 47 060 0002 09 47 060 0003 09 47 060 0004 09 47 060 0005 09 47 060 0007	09 47 030 0001 09 47 030 0002 09 47 030 0003 09 47 030 0004 09 47 030 0005 09 47 030 0007	09 47 040 0001 09 47 040 0002 09 47 040 0003 09 47 040 0004 09 47 040 0005 09 47 040 0007
HARTING RJ Industrial® System cable RJ45 angled, 4-wire one side pre-assembled, second side open Cable type B, green 2 x 2 x AWG 22/7	Length 0.5 m Length 1.0 m Length 1.5 m Length 2.0 m Length 3.0 m Length 5.0 m	09 47 050 0023 09 47 050 0024 09 47 050 0025 09 47 050 0026 09 47 050 0027 09 47 050 0029	09 47 060 0023 09 47 060 0024 09 47 060 0025 09 47 060 0026 09 47 060 0027 09 47 060 0029	09 47 030 0023 09 47 030 0024 09 47 030 0025 09 47 030 0026 09 47 030 0027 09 47 030 0029	09 47 040 0023 09 47 040 0024 09 47 040 0025 09 47 040 0026 09 47 040 0027 09 47 040 0029
HARTING RJ Industrial® System cable RJ45 angled, 4-wire one side pre-assembled, second side open Cable type C, green 2 x 2 x AWG 22/7	Length 0.5 m Length 1.0 m Length 1.5 m Length 2.0 m Length 3.0 m Length 5.0 m	09 47 050 0045 09 47 050 0046 09 47 050 0047 09 47 050 0048 09 47 050 0049 09 47 050 0051	09 47 060 0045 09 47 060 0046 09 47 060 0047 09 47 060 0048 09 47 060 0049 09 47 060 0051	09 47 030 0045 09 47 030 0046 09 47 030 0047 09 47 030 0048 09 47 030 0049 09 47 030 0051	09 47 040 0045 09 47 040 0046 09 47 040 0047 09 47 040 0048 09 47 040 0049 09 47 040 0051
HARTING RJ Industrial® System cable RJ45 angled, 4-wire one side pre-assembled, second side open Outdoor cable, black 2 x 2 x AWG 22/7	Length 0.5 m Length 1.0 m Length 1.5 m Length 2.0 m Length 3.0 m Length 5.0 m	09 47 050 0067 09 47 050 0068 09 47 050 0069 09 47 050 0070 09 47 050 0071 09 47 050 0073	09 47 060 0067 09 47 060 0068 09 47 060 0069 09 47 060 0070 09 47 060 0071 09 47 060 0073	09 47 030 0067 09 47 030 0068 09 47 030 0069 09 47 030 0070 09 47 030 0071 09 47 030 0073	09 47 040 0067 09 47 040 0068 09 47 040 0069 09 47 040 0070 09 47 040 0071 09 47 040 0073

RJ45
RJ Industrial

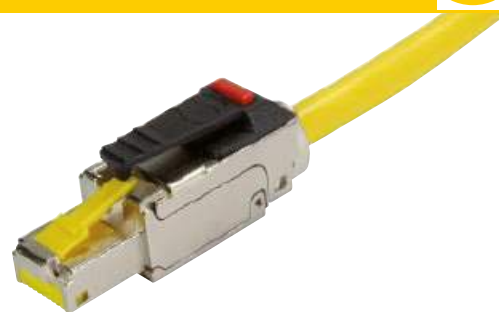

Ha-VIS preLink® RJ45 connector

Advantages

- RJ45 Ethernet-Data connector suitable for industry
- Compact and robust design
- 360° shielding
- Ergonomically unlocking clip
- Category of transmission Cat. 6_A
- Suitable for solid and stranded wires
- Suitable for PoE (IEEE 802.3af) and PoE+ (IEEE 802.3at)

Technical characteristics

Connector type	RJ45 connector acc. to IEC 60 603-7
Number of contacts	8
Transmission category	Category 6 _A , Class E _A , suitable for 1/10 Gigabit Ethernet
Transmission performance	Category 6 _A / Class E _A up to 500 MHz acc. to ISO/IEC 11 801:2002, EN 50 173-1
Transmission rate	10/100 Mbit/s and 1/10 Gbit/s
Shielding	fully shielded, 360° shielding contact
Mounting	IDC termination
Cable termination for preLink® terminal module, yellow, 20 82 000 0001	
Connectable cables	
– Conductor cross section	AWG 23 ... AWG 22 (solid and stranded)
– Conductor diameter	1.3 ... 1.6 mm
Cable termination for preLink® terminal module, white, 20 82 000 0003	
Connectable cables	
– Conductor cross section	AWG 27 ... AWG 26 (solid and stranded)
– Conductor diameter	0.8 ... 1.1 mm
Cable diameter	5 ... 9 mm
Degree of protection	IP20
Mating cycles	min. 750
Temperature range	-40 °C ... +70 °C
Housing material	Zinc die-cast, nickel-plated

Identification	Part number	Drawing	Dimensions in mm
Ha-VIS preLink® RJ45 connector	20 82 101 0010		
Ha-VIS preLink® RJ45 terminal module	20 82 000 0001		
AWG 22/23, yellow ¹⁾ AWG 26/27, white ¹⁾	20 82 000 0003		
Ha-VIS preLink® assembly tool	20 82 000 9901		

Identification	Colour	Part number
Colour clips for colour coding the Ha-VIS preLink® connectors	White	09 45 850 0001
	Grey	09 45 850 0002
	Yellow	09 45 850 0003
	Magenta	09 45 850 0005
	Red	09 45 850 0007
	Blue	09 45 850 0008
	Green	09 45 850 0009
	Brown	09 45 850 0010

¹⁾ Packaging with 10 pieces



Ha-VIS preLink® RJ45 jacks (HIFF)

Advantages

- Compact and robust design
- Category of transmission Cat. 6
- Suitable for solid and stranded wires
- Compatible with HIFF dimensions for use in:
 - Han® 3 A series with HIFF adapter 09 45 515 0024
 - HARTING PushPull (V4)
 - Compact bulkhead mounting housing 09 45 545 0028
 - EasyInstall bulkhead mounting housing 09 45 545 0032
 - Han® PushPull (V14)
 - Panel feed-through plastic 09 35 012 0331
 - Panel feed-through metal rectangular 09 35 012 0311
 - Panel feed-through metal circular 09 35 012 0312
 - *har*-port 09 45 452 0000
- Suitable for PoE (IEEE 802.3af) and PoE+ (IEEE 802.3at)

Technical characteristics

Connector type	RJ45 connector acc. to IEC 60 603-7
Number of contacts	8
Transmission category	Category 6 _A , Class E _A , suitable for 1/10 Gigabit Ethernet
Transmission performance	Category 6 _A / Class E _A up to 500 MHz acc. to ISO/IEC 11 801:2002, EN 50 173-1
Transmission rate	10/100 Mbit/s and 1/10 Gbit/s
Shielding	fully shielded, 360° shielding contact
Mounting	IDC termination
Cable termination for preLink® terminal module,	yellow, 20 82 000 0001
Connectable cables	
– Conductor cross section	AWG 23 ... AWG 22 (solid and stranded)
– Conductor diameter	1.3 ... 1.6 mm
Cable termination for preLink® terminal module,	white, 20 82 000 0003
Connectable cables	
– Conductor cross section	AWG 27 ... AWG 26 (solid and stranded)
– Conductor diameter	0.8 ... 1.1 mm
Cable diameter	5 ... 9 mm
Degree of protection	IP20
Mating cycles	min. 750
Temperature range	-40 °C ... +70 °C
Housing material	Zinc die-cast, nickel-plated

Identification	Part number	Drawing	Dimensions in mm
Ha-VIS preLink® set RJ45 jack consists of: • 1x RJ45 module • 1x terminal module • 1x cable tie	AWG 22/23 20 82 001 0001 AWG 26/27 20 82 001 0002		
Ha-VIS preLink® RJ45 jack module	20 82 000 0002		
Ha-VIS preLink® RJ45 terminal module	AWG 22/23, yellow ¹⁾ 20 82 000 0001 AWG 26/27, white ¹⁾ 20 82 000 0003		
Ha-VIS preLink® protection cover	20 82 000 9915		
Ha-VIS preLink® unlocking tool	20 82 000 9916		
Ha-VIS preLink® assembly tool	20 82 000 9901		

¹⁾ Packaging with 10 pieces



Ha-VIS preLink®
19" Patch panel, HIFF

Advantages

- Flexible, suitable for Ha-VIS preLink® modules RJ45 jack and HARTING RJ Industrial® modules in HIFF size
- Economical, time-saving installation due to the slidable module carrier, frontward and backward removal
- Safety, additional strain-relief
- Fully shielded modules connected by module carrier
- Earth bolt
- IP20 installation for distributors and switch cabinets

Technical characteristics

Number of modules	24
Transmission performance	Category 6 / Class E _A up to 500 MHz acc. to ISO/IEC 11 801:2002, EN 50 173-1
Transmission rate	up to 10 Gbit/s
Assembly	in 19" racks acc. to IEC/DIN EN 60 297-3-100 (DIN 41 494-1)
Dimensions (W x H x D)	482.6 mm (19") x 44.5 mm (1 U) x 181 mm
Degree of protection	IP20
Operating temperature range	-40 °C ... +70 °C
Material	
module carrier, 2-parts	steel sheet
front cover	stainless steel

Identification	Part number	Drawing	Dimensions in mm
----------------	-------------	---------	------------------

Ha-VIS preLink®
19" patch panel, unloaded

20 82 400 0001

Suitable modules:

- Ha-VIS preLink® RJ45 jack, HIFF
- mixed loading possible

Range of delivery::

- Screw set M5
- 24 cable ties
- 1x earth conductor 6 mm²

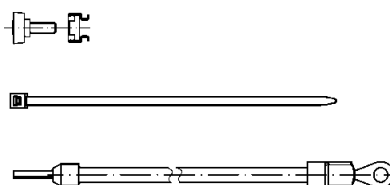
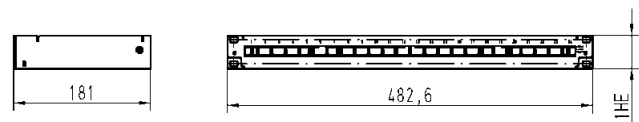



Ha-VIS preLink® HIFF RJ45 AP Box

Advantages

- Flexible, suitable for on-wall mounting or for top-hat mounting rail (35 mm)
- Economical, time-saving installation due to the use of pre-assembled data cables with Ha-VIS preLink® termination
- Robust design, powder-coated steel plate housing
- Structured cabling for industrial premises

Technical characteristics

Number of ports, Copper / Termination	2 / RJ45 jack HIFF
Transmission performance	Category 6 / Class E _A up to 500 MHz acc. to ISO/IEC 11 801:2002, EN 50 173-1
Transmission rate	up to 10 Gbit/s
Shielding	Fully shielded, 360° shielding contact
Cable diameter	5 mm ... 9 mm
Mounting	on-wall or DIN Rail
Dimensions (WxHxD)	60 x 81 x 70 mm
Degree of protection	IP20
Operating temperature	-40 °C ... +70 °C
Housing material	steel plate
Colour	Anthracite grey (RAL 7016)

Identification	Part number	Drawing	Dimensions in mm
<p>Ha-VIS preLink® HIFF RJ45 AP Box</p> <p>RJ45 wall-mounted box consisting of:</p> <ul style="list-style-type: none"> • 1x steel-plate housing, 2-parts • 2x Ha-VIS preLink® Set, RJ45 jack HIFF, AWG 22/23 • 2x grommet with membrane • 1x assembly instruction 	20 82 101 0220		
<p>Accessory</p> <p>DIN Rail mounting bracket</p>	20 80 000 0003		

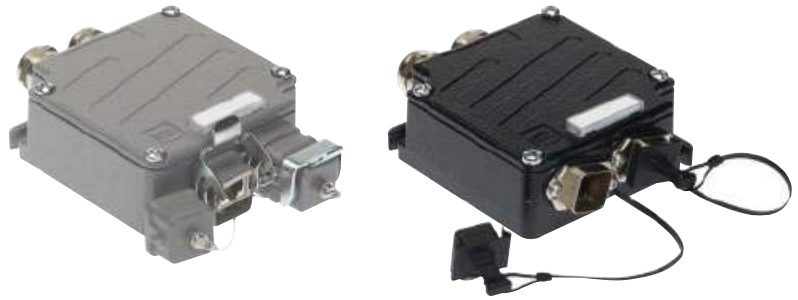

Ha-VIS preLink® Han® PushPull Metal Outlet and Han® 3 A Metal Outlet

Advantages

- Simple mounting, fixing and earth connection both outside
- Fast termination of data cables due to Ha-VIS preLink® technology
- Structured cabling for industrial premises
- Mating face AIDA compliant, protection cover incl.
- PROFINET compatible

Technical characteristics

Number of ports, Copper / Termination	2 x Han® PushPull RJ45 (IP65 / IP67) or Han® 3 A RJ45
Transmission performance	Category 6 / Class E _A up to 500 MHz acc. to ISO/IEC 11 801:2002, EN 50 173-1
Transmission rate	up to 10 Gbit/s
Termination	Ha-VIS preLink®
Wire gauge	AWG 24 ... 22 (0.25 mm ² ... 0.34 mm ²) solid and stranded
Strand diameter	Ø 1.3 mm ... 1.6 mm
Cable diameter	7.2 mm ... 8 mm
Shielding	Fully shielded 360° flexible shielding termination
Mounting	Wall mounting
Dimensions (H x W x D)	105 x 105 x 40.5 mm
Degree of protection	IP65 / IP67
Operating temperature range	-40 °C ... +70 °C
Housing material	Aluminium, die-cast
Colour	Black

Identification	Part number	Drawing	Dimensions in mm
Ha-VIS preLink® Han® PushPull Metal Outlet consists of: <ul style="list-style-type: none"> • 1x Housing including protection covers • 2x Ha-VIS preLink® Set RJ45 jack AWG 22/23 • 2x Cable gland with slotted seal • 1x Assembly instruction 	20 82 104 0101		
Ha-VIS preLink® Han® 3 A Metal Outlet consists of: <ul style="list-style-type: none"> • 1x Housing including protection covers • 2x Ha-VIS preLink® Set RJ45 jack AWG 22/23 • 2x Cable gland with slotted seal • 1x Assembly instruction 	20 82 102 0101		



Ha-VIS preLink® RJ45 jack
(keystone version)

Advantages

- RJ45 Ethernet-Data jack suitable for industry
- Compact and robust design
- 360° shielding
- Ergonomically unlocking clip
- Category of transmission Cat. 6A
- Suitable for solid and stranded wires
- Compatible with keystone panel cut out acc. to IEC 60 603-7
- Suitable for PoE (IEEE 802.3af) and PoE+ (IEEE 802.3at)

Technical characteristics

Connector type	RJ45 connector acc. to IEC 60 603-7
Number of contacts	8
Transmission category	Category 6A, Class E _A , suitable for 1/10 Gigabit Ethernet
Transmission performance	Category 6A / Class E _A up to 500 MHz acc. to ISO/IEC 11 801:2002, EN 50 173-1
Transmission rate	10/100 Mbit/s and 1/10 Gbit/s
Shielding	fully shielded, 360° shielding contact
Mounting	IDC termination
Cable termination for preLink® terminal module, yellow, 20 82 000 0001	
Connectable cables	
– Conductor cross section	AWG 23 ... AWG 22 (solid and stranded)
– Conductor diameter	1.3 ... 1.6 mm
Cable termination for preLink® terminal module, white, 20 82 000 0003	
Connectable cables	
– Conductor cross section	AWG 27 ... AWG 26 (solid and stranded)
– Conductor diameter	0.8 ... 1.1 mm
Cable diameter	5 ... 9 mm
Degree of protection	IP20
Mating cycles	min. 750
Temperature range	-40 °C ... +70 °C
Housing material	Zinc die-cast, nickel-plated

Identification	Part number	Drawing	Dimensions in mm
Ha-VIS preLink® set RJ45 keystone jack consists of: <ul style="list-style-type: none"> • 1x RJ45 module • 1x terminal module • 1x cable tie AWG 22/23	20 82 501 0001		
Ha-VIS preLink® RJ45 keystone jack module	20 82 500 0001		
Ha-VIS preLink® RJ45 angled keystone jack module	20 82 500 0002 ²⁾		
Ha-VIS preLink® RJ45 terminal module AWG 22/23, yellow ¹⁾ AWG 26/27, white ¹⁾	20 82 000 0001 20 82 000 0003		
Ha-VIS preLink® protection cover	20 82 000 9915		
Ha-VIS preLink® unlocking tool	20 82 000 9916		
Ha-VIS preLink® assembly tool	20 82 000 9901		

¹⁾ Packaging with 10 pieces
²⁾ Packaging with 24 pieces



Ha-VIS preLink®
19" Patch panel, keystone

Advantages

- Suitable for Ha-VIS preLink® RJ45 module in keystone size
- Economic due to easy design
- Safety, additional strain-relief
- Fully shielded modules connected through metal holding fixture
- Earth bolt

Technical characteristics

Number of modules	24
Transmission performance	Category 6 / Class E _A up to 500 MHz acc. to ISO/IEC 11 801:2002, EN 50 173-1
Transmission rate	up to 10 Gbit/s
Module design	Keystone size acc. to EN 60 603-7:2009
Assembly	in 19" racks acc. to IEC/DIN EN 60 297-3-100 (DIN 41 494-1)
Dimensions (W x H x D)	482.6 mm (19") x 44.5 mm (1 U) x 107 mm
Degree of protection	IP20
Operating temperature range	-40 °C ... +70 °C
Material	steel sheet

Identification	Part number	Drawing	Dimensions in mm
----------------	-------------	---------	------------------

Ha-VIS preLink®
19" patch panel, keystone

20 82 405 0001

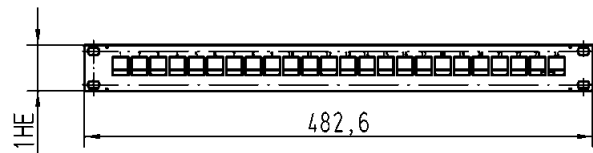

Range of delivery:

24 pieces of:

- Ha-VIS preLink® RJ45 keystone jack
- terminal modules for AWG 22 / 23
- strain relief

Ha-VIS preLink®
19" patch panel, keystone
empty

20 82 400 0002

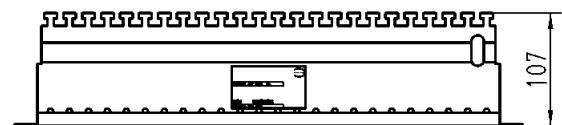



HARTING Cabinet Outlet RJ45, 8-poles
RJ45 distribution module for IP20 environments
(top-hat rail mounting)

Advantages

- Simple mounting
- Dust protection caps
- Port identification
- Angled output

Technical characteristics

Number of ports, Copper / Termination	1 / RJ45 (Twisted Pair)
Transmission performance	Category 6A / Class EA up to 250 MHz acc. to ISO/IEC 11 801:2002, EN 50 173-1
Transmission rate	10/100 Mbit/s and 1/10 Gbit/s
Mounting	To 35 mm top-hat mounting rail acc. to DIN EN 60 715, alignable
Dimensions (H x W x D)	71 x 18 x 68 mm
Degree of protection	IP20
Operating temperature range	-20 °C ... +70 °C
Housing material	Polyamide, UL94 V-0
Colour	Grey

Identification	Part number	Drawing	Dimensions in mm
HARTING RJ Industrial® Cabinet Outlet RJ45	09 45 851 0000		
Protection cover set for 09 45 851 0000	09 45 851 0001		
Usable RJ45 cable jacks			
• Ha-VIS preLink® keystone set AWG 22/23 (with Ha-VIS preLink® terminal block)	20 82 501 0001		
• Ha-VIS preLink® keystone set (without Ha-VIS preLink® terminal block)	20 82 500 0001		
Usable with Ha-VIS preLink® terminal blocks			
• Ha-VIS preLink® terminal block AWG 22/23 (24)	20 82 000 0001		
• Ha-VIS preLink® terminal block AWG 26/27	20 82 500 0003		
Usable RJ45 cable jacks			
• RJ45 keystone module IDC AWG 24 – AWG 22	09 45 545 1564		
• RJ45 keystone module IDC AWG 27 – AWG 26	09 45 545 1563		



Ha-VIS preLink® Patch cables

Advantages

- Pre-assembled system cable, fast, flexible and reliable in the application
- Simple in handling
- Robust in design
- Installation of Ha-VIS preLink® cables for industrial environment
- Connection cable for control or distributor cabinets or within controllers

Technical characteristics

Cable types	4 x 2 AWG 27/7, shielded, S/FTP Cat. 7
Sheath material	PUR
Wiring	TIA/EIA 568B, 1:1
Transmission performance	Category 6 / Class E _A up to 500 MHz acc. to ISO/IEC 11 801:2002, EN 50 173-1
Transmission rate	up to 10 Gbit/s
Shielding	Copper braid, tinned
Operating temperature range	
fixed operation	-35 °C ... +70 °C
flexible operation	-5 °C ... +50 °C
Standard lengths	0.6 m / 1 m / 2 m / 3 m / 5 m / 10 m other lengths available on request
Colour	Yellow

Identification	Part number	Drawing	Dimensions in mm
Ha-VIS preLink® Patch cable			
	Yellow		
terminal module to one side, secured by protection cap I	Length 0.2 m	20 82 600 1002	
	0.4 m	20 82 600 1004	
	0.6 m	20 82 600 1006	
	0.8 m	20 82 600 1008	
	1.0 m	20 82 600 1010	
	2.0 m	20 82 600 1020	
	3.0 m	20 82 600 1030	
	4.0 m	20 82 600 1040	
	5.0 m	20 82 600 1050	
	10.0 m	20 82 600 1100	
terminal module to both sides, secured by protection cap II	Length 0.2 m	20 82 600 2002	
	0.4 m	20 82 600 2004	
	0.6 m	20 82 600 2006	
	0.8 m	20 82 600 2008	
	1.0 m	20 82 600 2010	
	2.0 m	20 82 600 2020	
	3.0 m	20 82 600 2030	
	4.0 m	20 82 600 2040	
	5.0 m	20 82 600 2050	
	10.0 m	20 82 600 2100	
Side 1 with terminal module, secured by protection cap III	Length 0.2 m	20 82 601 1002	
	0.4 m	20 82 601 1004	
	0.6 m	20 82 601 1006	
	0.8 m	20 82 601 1008	
	1.0 m	20 82 601 1010	
	2.0 m	20 82 601 1020	
	3.0 m	20 82 601 1030	
	4.0 m	20 82 601 1040	
	5.0 m	20 82 601 1050	
	10.0 m	20 82 601 1100	



Ha-VIS preLink® Extender

Advantages

- Simple, fast and reliable connection of data cables
- Compact and robust design
- 360° shielding
- Category of transmission Cat. 6_A
- Suitable for solid and stranded wires

Application

- Extension of cables for data communication
- Connection of cables with different cross-sections
- Linking of fire compartments

Technical characteristics

Connector type	RJ45 connector acc. to IEC 60 603-7
Number of contacts	8
Transmission category	Category 6 _A , Class E _A , suitable for 1/10 Gigabit Ethernet
Transmission performance	Category 6 _A / Class E _A up to 500 MHz acc. to ISO/IEC 11 801:2002, EN 50 173-1
Transmission rate	10/100 Mbit/s and 1/10 Gbit/s
Shielding	fully shielded, 360° shielding contact
Mounting	IDC termination
Cable termination for preLink® terminal module, yellow, 20 82 000 0001	
Connectable cables	
– Conductor cross section	AWG 23 ... AWG 22 (solid and stranded)
– Conductor diameter	1.3 ... 1.6 mm
Cable termination for preLink® terminal module, white, 20 82 000 0003	
Connectable cables	
– Conductor cross section	AWG 27 ... AWG 26 (solid and stranded)
– Conductor diameter	0.8 ... 1.1 mm
Cable diameter	5 ... 9 mm
Degree of protection	IP20
Mating cycles	min. 750
Temperature range	-40 °C ... +70 °C
Housing material	Zinc die-cast, nickel-plated

Identification	Part number	Drawing	Dimensions in mm
Ha-VIS preLink® Extender	20 82 101 0001		
Ha-VIS preLink® RJ45 terminal module	20 82 000 0001 20 82 000 0003		
AWG 22/23, yellow ¹⁾ AWG 26/27, white ¹⁾			
Ha-VIS preLink® assembly tool	20 82 000 9901		

¹⁾ Packaging with 10 pieces



Ha-VIS preLink® M12 connector
D-coding

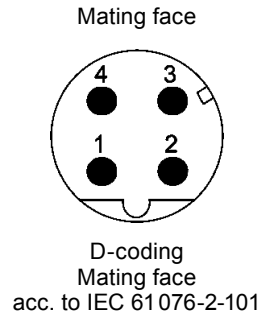

RJ45 Industrial

Advantages

- M12 Ethernet-Data connector suitable for industry
- Robust design
- 360° shielding
- Suitable for solid and stranded wires
- Suitable for PoE (IEEE 802.3af) and PoE+ (IEEE 802.3at)

Technical characteristics

Connector type	M12 D-coding acc. to IEC 61 076-2-101
Number of contacts	4
Transmission category	Category 5, Class D, suitable for 1/10 Gigabit Ethernet
Transmission performance	Category 5 / Class D up to 200 MHz acc. to ISO/IEC 11 801:2002, EN 50 173-1
Transmission rate	10/100 Mbit/s
Shielding	fully shielded, 360° shielding contact
Mounting	IDC termination
Cable termination for preLink® Connectable cables	terminal module, yellow, 20 82 000 0001
– Conductor cross section	AWG 23 ... AWG 22 (solid and stranded)
– Conductor diameter	1.3 ... 1.6 mm
Cable termination for preLink® Connectable cables	terminal module, white, 20 82 000 0003
– Conductor cross section	AWG 27 ... AWG 26 (solid and stranded)
– Conductor diameter	0.8 ... 1.1 mm
Cable diameter	5 ... 9 mm
Degree of protection	IP65 / IP67
Mating cycles	min. 750
Temperature range	-40 °C ... +70 °C
Housing material	Zinc die-cast, nickel-plated

Identification

Part number

Drawing

Dimensions in mm

preLink® M12 housing



20 82 000 1210

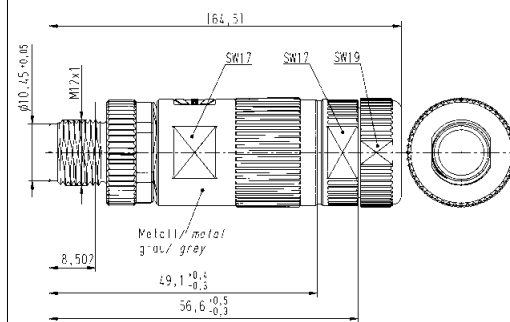

preLink® M12 male module

Male
4 poles,
D-coding



20 82 005 1214

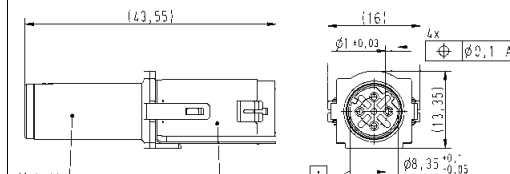

preLink® M12 connector set

D-coding

20 82 005 0001

Ha-VIS preLink® RJ45 terminal module

AWG 22/23, yellow¹⁾
AWG 26/27, white¹⁾

20 82 000 0001
20 82 000 0003

Ha-VIS preLink® assembly tool

20 82 000 9901

¹⁾ Packaging with 10 pieces



RJ45 Industrial

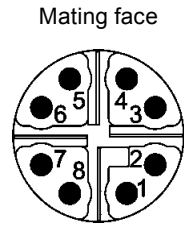

X-coding Mating face acc. to IEC 61 076-2-101



Ha-VIS preLink® M12 connector X-coding

Advantages



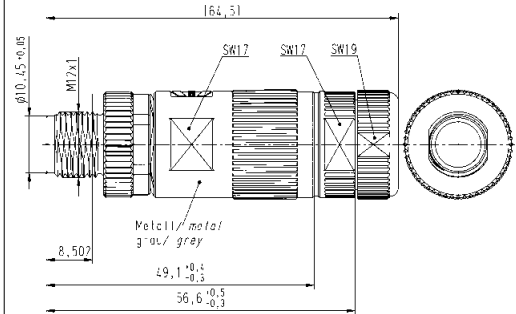

- M12 Ethernet-Data connector suitable for industry
- Robust design
- 360° shielding
- Category of transmission Cat. 6A
- Suitable for solid and stranded wires
- Suitable for PoE (IEEE 802.3af) and PoE+ (IEEE 802.3at)

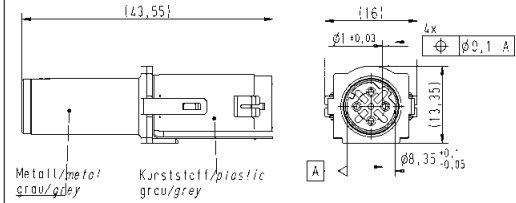
Technical characteristics

Connector type	M12 X-coding acc. to IEC 61 076-2-101
Number of contacts	8
Transmission category	Category 6A, Class EA, suitable for 1/10 Gigabit Ethernet
Transmission performance	Category 6A / Class EA up to 500 MHz acc. to ISO/IEC 11 801:2002, EN 50 173-1
Transmission rate	10/100 Mbit/s and 1/10 Gbit/s
Shielding	fully shielded, 360° shielding contact
Mounting	IDC termination
Cable termination for preLink® Connectable cables	terminal module, yellow, 20 82 000 0001
– Conductor cross section	AWG 23 ... AWG 22 (solid and stranded)
– Conductor diameter	1.3 ... 1.6 mm
Cable termination for preLink® Connectable cables	terminal module, white, 20 82 000 0003
– Conductor cross section	AWG 27 ... AWG 26 (solid and stranded)
– Conductor diameter	0.8 ... 1.1 mm
Cable diameter	5 ... 9 mm
Degree of protection	IP65 / IP67
Mating cycles	min. 750
Temperature range	-40 °C ... +70 °C
Housing material	Zinc die-cast, nickel-plated

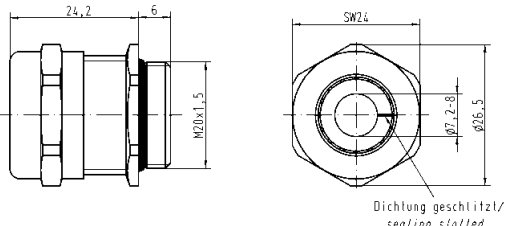
Identification	Part number	Drawing	Dimensions in mm
preLink® M12 housing 	20 82 000 1210		
preLink® M12 male module Male 8 poles, X-coding 	20 82 006 1218		
preLink® M12 connector set X-coding	20 82 005 0002		
Ha-VIS preLink® RJ45 terminal module AWG 22/23, yellow ¹⁾ AWG 26/27, white ¹⁾	20 82 000 0001 20 82 000 0003		
Ha-VIS preLink® assembly tool	20 82 000 9901		

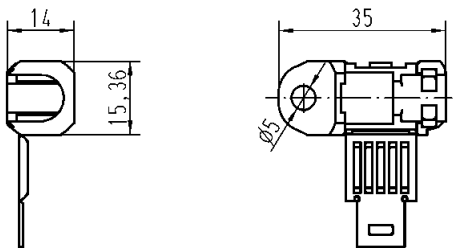
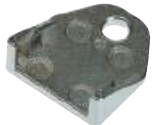
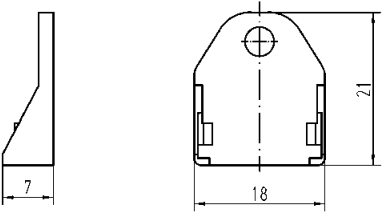
¹⁾ Packaging with 10 pieces

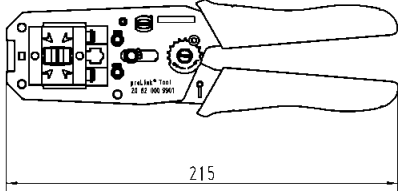
Identification	Part number	
<p>Cable gland M20x1.5 for pre-terminated Ha-VIS preLink® cable assemblies</p> <p>with slotted seal</p> <p>Cable-sheath 7.2 mm ... 8.0 mm</p> <p>Cable-sheath 4.0 mm ... 6.5 mm</p> 	<p>19 00 000 5020</p> <p>19 00 000 5079</p>	
<p>Protection cover for pre-terminated Ha-VIS preLink® cable assemblies</p> <p>Set of 10 pieces</p> 	<p>20 82 000 9915</p>	
<p>Unlocking tool for Ha-VIS preLink® RJ45 module</p> <p>Set of 5 pieces</p> 	<p>20 82 000 9916</p>	
<p>HARTING Assembly tool for Ha-VIS preLink® terminal module</p> 	<p>20 82 000 9901</p>	



har-port USB coupler

Advantages

- Compact and well-shaped service interface in a timeless attractive design
- Easy mounting
- Compact and robust design
- Practical accessories

Technical characteristics

Mounting	Screwable in cover plates (thread M22 x 1)
Degree of protection	IP20
Mating cycles	min. 1500
Temperature range	-25 °C ... +70 °C
Housing material	Polyamide

Identification	Part number		Drawing	Dimensions in mm
	silver	black		
har-port USB 2.0 coupler Type A jack – Type A jack	09 45 452 1901	09 45 452 1903		
har-port USB 3.0 coupler Type A jack – Type A jack	09 45 452 1902	09 45 452 1904		
har-port USB 2.0 coupler with cable Type A jack – Type A connector Length: 0.5 m 1.0 m 1.5 m 2.0 m 3.0 m 5.0 m	09 45 452 1920 09 45 452 1921 09 45 452 1922 09 45 452 1923 09 45 452 1924 09 45 452 1925	09 45 452 1960 09 45 452 1961 09 45 452 1962 09 45 452 1963 09 45 452 1964 09 45 452 1965		
Type B jack – Type B connector Length: 0.5 m 1.0 m 1.5 m 2.0 m 3.0 m 5.0 m	09 45 452 1910 09 45 452 1911 09 45 452 1912 09 45 452 1913 09 45 452 1914 09 45 452 1915			

har-port USB coupler

Identification	Part number		Drawing	Dimensions in mm
	silver	black		
har-port USB 2.0 coupler 2 x Type A jack – Type A connector Length: 0.5 m 1.0 m 1.5 m 2.0 m 3.0 m 5.0 m	09 45 452 1950 09 45 452 1951 09 45 452 1952 09 45 452 1953 09 45 452 1954 09 45 452 1955			
har-port USB 3.0 coupler Type A jack – Type A connector Length: 0.5 m 1.0 m 1.5 m 2.0 m 3.0 m 5.0 m	09 45 452 1930 09 45 452 1931 09 45 452 1932 09 45 452 1933 09 45 452 1934 09 45 452 1935	09 45 452 1970 09 45 452 1971 09 45 452 1972 09 45 452 1973 09 45 452 1974 09 45 452 1975		
har-port USB 2.0 coupler Type Mini-B jack – Type A connector Length: 0.5 m	09 45 452 1940			



har-port RJ45 coupler

Advantages

- Compact and well-shaped service interface in a timeless attractive design
- Easy mounting
- Transmission category 6, performance class E_A, suitable for 1/10 Gigabit Ethernet
- Compact and robust design
- Practical accessories

Technical characteristics

Number of ports	2x RJ45
Transmission performance	Category 6 / class E _A acc. to ISO/IEC 11801:2002, EN 50 173-1
Transmission rate	10/100 Mbit/s and 1/10 Gbit/s
Shielding	Fully shielded, 360° shielding contact
Mounting	Screwable in cover plates
Degree of protection	IP20
Mating cycles	min. 750
Temperature range	-25 °C ... +70 °C
Housing material	Polyamide

Identification	Part number		Drawing	Dimensions in mm
	silver	black		
har-port RJ45 Cat. 6 coupler	09 45 452 1560	09 45 452 1561		
har-port RJ45 Cat. 6 coupler with cable				
Length:				
0.15 m	09 45 452 1500	09 45 452 1530		
0.2 m	09 45 452 1501	09 45 452 1531		
0.3 m	09 45 452 1502	09 45 452 1532		
0.5 m	09 45 452 1504	09 45 452 1534		
0.7 m	09 45 452 1506	09 45 452 1536		
1.0 m	09 45 452 1509	09 45 452 1539		
1.5 m	09 45 452 1510	09 45 452 1540		
2.0 m	09 45 452 1511	09 45 452 1541		
2.5 m	09 45 452 1512	09 45 452 1542		
3.0 m	09 45 452 1513	09 45 452 1543		
3.5 m	09 45 452 1514	09 45 452 1544		
4.0 m	09 45 452 1515	09 45 452 1545		
5.0 m	09 45 452 1516	09 45 452 1546		
7.5 m	09 45 452 1517	09 45 452 1547		
10.0 m	09 45 452 1518	09 45 452 1548		
har-port HIFF coupler housing (for all HIFF compatible modules)	09 45 452 0000	09 45 452 0001		

har-port RJ45 coupler

Identification	Part number silver	Drawing	Dimensions in mm
<p>har-port audio interface 3.5 mm stereo phone jack jack to connector</p> <p>Length: 1.0 m 2.0 m</p>	<p>09 45 452 1000 09 45 452 1001</p>		
<p>HDMI video interface</p>	<p>09 45 452 1010</p>		



har-port accessories

Advantages

- Compact and well-shaped service interface in a timeless attractive design
- Easy mounting
- Compact and robust design
- Practical accessories

Technical characteristics

Temperature range -25 °C ... +70 °C
 Housing material Polyamide

Identification	Part number	Drawing	Dimensions in mm
Accessories			
har-port protection cover IP65 / IP67 black	09 45 502 0000		
har-port sealing cover	09 45 502 0001		
har-port label holder	09 45 502 0002	 har-port label holder 09 45 502 0002	
har-port label for label holder 09 45 502 0002	09 45 502 0003	 position for har-port label 09 45 502 0003	
har-port blind cover IP65 / IP67	09 45 502 0004		
har-port protection cover IP65 / IP67 transparent	09 45 502 0005		
har-port protection cover IP65 / IP67 metal	09 45 502 0006		

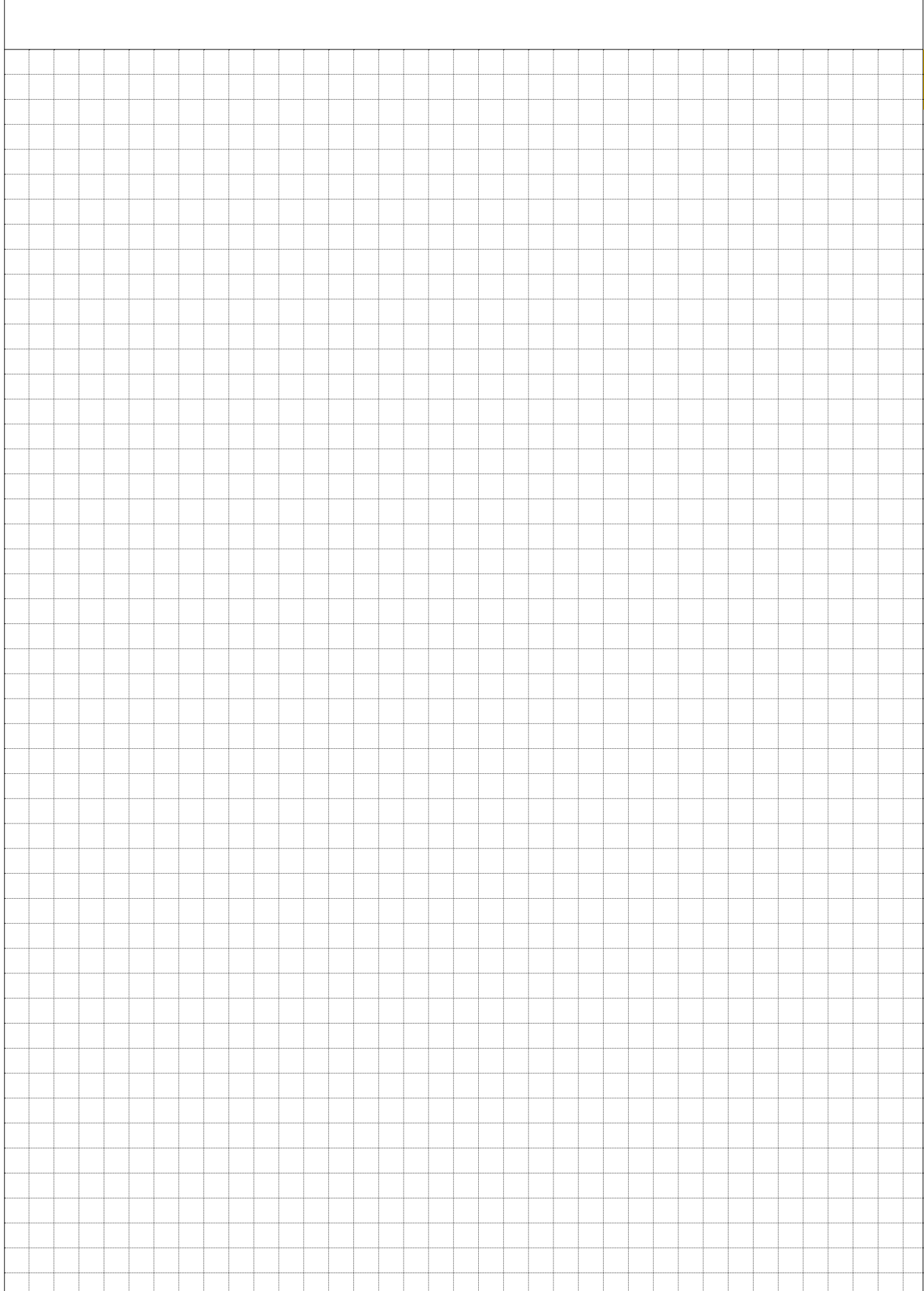

02. PushPull Connectors

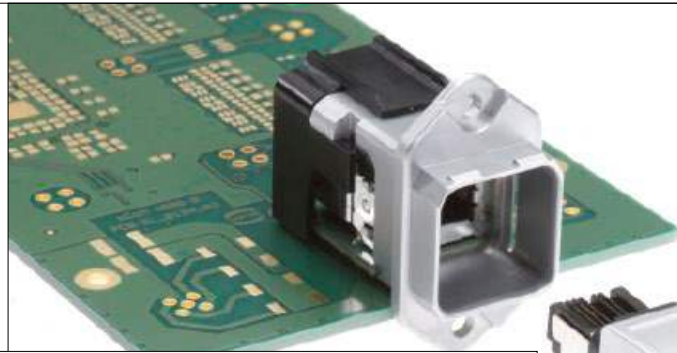

A distributed automation system does not contain any central automated control cabinets. Controls, sensors and actuators are designed for a high degree of protection (IP65 / IP67) and are installed directly in the field. In connection with these innovative installation concepts with distributed devices, users are demanding a standard connector family that is compatible with all interfaces. In response to these needs, the HARTING PushPull series has set the respective new appliance connection standard. PushPull technology is available for data, signal and power applications. Other interfaces accommodating USB or fiber optics (LC, SCRJ) supplement the universal range of the PushPull solutions. The integration of communication and power lines in a hybrid PushPull connector is a genuine trend-setting advance. In view of these strengths, the PushPull container has become the standard for current and future appliance interfaces. The German automotive industry, for example, has opted for the implementation of the PushPull connector family.

Application profile:

CONNECTION TYPE		ENVIRONMENT		APPLICATION						
Board to Board	Cable/Wire to Board	IP20	IP65 / IP67	Data	Signal	Power	high performance			
							Data transfer rate	Shielding	Number of contacts, contact density	Voltage, working current
Cable termination			PCB termination			Application standard				
Han-Quick Lock® IDC HARAX® Crimp			THT SMC SMT							
Screw Cage clamp Axial screw			Press-in			Housing integration				
						Separate housing Integrated housing				

1) Piercing contacts

Contents

Page

Introduction PushPull termination technology	02.02
 HARTING PushPull type acc. to IEC 61 076-3-106 variant 4	
HARTING PushPull – housing bulkhead mounting for device integration	02.04
HARTING PushPull RJ45	02.05
HARTING PushPull LC duplex	02.11
HARTING PushPull Hybrid	02.17
HARTING PushPull Signal	02.21
HARTING PushPull USB	02.23
HARTING PushPull Power, 4-poles, 48 V (12 A)	02.26
HARTING PushPull Power, 3-poles, 250 V (16 A)	02.29
HARTING PushPull Power – Tooling and accessories	02.30
 Han® PushPull type acc. to IEC 61 076-3-117 variant 14	
Han® PushPull RJ45	02.33
Han® PushPull SCRJ and tooling	02.48
Han® PushPull Signal	02.58
Han® PushPull Power 4/0, 5-poles, 230/400 V (16 A)	02.61
Han® PushPull Power 4/0 – Contacts and tooling	02.68
Han® PushPull Power L 4/0, 5-poles, 24 V (16 A)	02.70

The PushPull connector housing is a function container with degree of protection IP65 / IP67 and is available in two standardized housing sizes. These containers are equipped with standard RJ45, FOC or power contacts for operation at 5 x 16 A, depending on application requirements. The PushPull connector can be delivered either as plastic, or as metal variant, depending on the installation environment.

THE PushPull PRINCIPLE

PushPull connector applications combine two basic advantages:

1. Simple operation
2. Safe and vibration resistant sealed IP65 / IP67 connection.

The innovative PushPull lock mechanism dispenses with the need for a latching bracket. The connector can be inserted with one hand, minimum force and an audible click for safe operation. The connection can be removed again just as easily for service work.

COPPER, FOC AND POWER – IN THE SAME DESIGN

HARTING offers two series of the PushPull connector system, which differ in terms of their outer dimensions and module inserts.

Han® PushPull (IEC 61 076-3-117 VARIANT 14)

This series represents the standard PROFINET device interface for the IP67 environment of the German automobile manufacturing industry.

The connector is available as metal and as plastic version. The RJ45 module for copper conductors and the SCRJ module for FOCs are available as data connectors. The RJ45 variant is realized by means of the RJ Industrial module equipped with HARAX® quick connection technology. The power module which is installed in the same container can be assembled on-site, either with crimp contacts or with innovative Quick Lock® technology in order to wire the distributed field devices to 230/400 V (16 A) power. This 5-pole connector enables the transfer of two independent 24 V control



circuits with functional ground, or the transfer of a three-phase voltage of 400 V (16 A).

HARTING PushPull (IEC 61 076-3-106 VARIANT 4)

This extremely compact and space-saving series provides an Ethernet appliance connection with degree of protection IP65 / IP67 that requires no more installation space than a M12 connector. The RJ45 variant for copper conductors and the LC variant for FOCs are available as modules for data connectors. The RJ45 variant is realized by means of *HARAX*[®] quick connection technology as used with HARTING RJ Industrial[®]. The 4-pole module for 48 V (12 A) or the 3-pole module for 250 V (16 A) can be used to supply power to the distributed field devices.

HARTING PushPull HYBRID

The migration from Fieldbus to Ethernet within communication technology has simplified machine installation options. This

simplification is attained by combining the data and the 24 V power lines in a single hybrid cable with hybrid connector, in connection with the spatial requirements of an M12 connector. The HARTING PushPull Hybrid offers trend-setting connection technology for this new method of machine installation.

The PushPull Hybrid reduces everything by half: the number of connection points and cables, and spatial requirements for the connection technology.

The PushPull Hybrid makes everything easier: machine installation, the wiring of connectors and safe insertion.

APPLIANCE INTEGRATION:

In order to support the implementation of appliances with degree of protection IP65 / IP67, HARTING offers panel feed-through devices with integrated couplings and female contact modules for direct mounting on PCBs.

HARTING PushPull

ONE CONCEPT FOR DATA, SIGNAL AND POWER

The internationally standardized PushPull connector represents the latest generation of appliance connection technology with high degree of protection IP65 / IP67, easy insertion and snap-action engagement with audible click.

The PushPull housing family is designed for the integration of a wide range of contact inserts for data, signal and power lines.

INSTALLATION IN PLANTS

WITH Han[®] PushPull CONNECTORS:

- The standard for PROFINET communication
- One housing for the electrical and optical data transfer and for power supply
- Plastic or metal housing variants

INSTALLATION IN MACHINES

WITH HARTING PushPull HYBRID CONNECTORS:

- Combined data lines and appliance power supply up to 5 A in the same connector
- Compact size (comparable with M12)

POWER SUPPLY TO DISTRIBUTED DEVICES

USING PushPull CONNECTORS:

- Variant 4: 48 V (12 A), 4-pole or 250 V (16 A), 3-pole
- Variant 14: 400 V (12 A) 5-pole, or 24 V (16 A) 5-pole
- Latest connection technology QuickLock[®] for on-site assembly without special auxiliary tools





HARTING PushPull Technology acc. to IEC 61 076-3-106 variant 4 housing bulkhead mounting for device integration of RJ45-, USB- and Power-jacks

Advantages

- PushPull housing bulkhead mounting with HARTING PushPull technology
 - Compact, space-saving design for device integration of RJ45-, USB-, Signal- or Power-pcb female
- Housing bulkhead mounting EasyInstall
- for simple device integration round panel cut out
- Housing bulkhead mounting Compact
- high packing density (spacing 27 x 21 mm)

Technical characteristics

Locking	PushPull Technology acc. to IEC 61 076-3-106 variant 4
Shielding	fully shielded, 360° shielding contact
Mating cycles	min. 750
Degree of protection	IP65 / IP67
Temperature range	-40 °C ... +70 °C
Housing material	Plastic, black Zinc die-cast, shining
Flammability acc. to UL 94	V0
	UL approval (E102079)

Identification	Part number	Drawing	Dimensions in mm
<p>Components device side</p> <p>Housing bulkhead mounting – EasyInstall with integrated seal board drillings for M3</p> <p>without fixing clip</p> <p>with fixing clip</p> <p>with fixing clip, for all HIFF compatible modules</p>	<p>09 45 545 0030¹⁾ 09 45 595 0030²⁾⁴⁾</p> <p>09 45 545 0031³⁾ 09 45 595 0031³⁾⁴⁾ 09 45 545 0032</p>	<p>Panel cut out</p>	
<p>Housing bulkhead mounting – Compact Board drillings for M2.5</p> <p>without fixing clip (incl. flat seal)</p> <p>without fixing clip (with integrated seal)</p> <p>with fixing clip (incl. flat seal)</p> <p>with fixing clip (with integrated seal)</p> <p>with fixing clip (with integrated seal) for vertical RJ jack 09 45 551 1103</p> <p>with fixing clip, for all HIFF compatible modules</p>	<p>09 45 545 0023²⁾ 09 45 545 0033²⁾</p> <p>09 45 545 0021³⁾ 09 45 545 0029³⁾ 09 45 545 0027</p> <p>09 45 545 0028</p>		

1) suitable RJ45 jacks: 09 45 551 1100 / ... 1110 / ... 1102 / ... 1103 / ... 1130 / ... 1530
 2) suitable RJ45 jacks: 09 45 551 1100 / ... 1110 / ... 1102 / ... 1130 / ... 1530
 3) suitable RJ45 jacks: 09 45 551 1100 / ... 1110 / ... 1102
 4) Metal version



HARTING PushPull Technology acc. to IEC 61 076-3-106 variant 4
RJ45 jacks and accessories

Advantages

- HARTING PushPull technology
- Low-profile jacks for space-saving PCB integration
- Category of transmission Cat. 5
- Suitable for PoE (IEEE 802.3af) and PoE+ (IEEE 802.3at)

Technical characteristics

Locking	PushPull Technology acc. to IEC 61 076-3-106 variant 4
Transmission rate	10/100/1000 Mbit/s
Shielding	fully shielded, 360° shielding contact
Mating cycles	min. 750
Degree of protection	IP65 / IP67
Temperature range	-40 °C ... +70 °C
Housing material	Plastic, black
Flammability acc. to UL 94	V0
	UL approval (E102079)

Identification	Part number	Drawing	Dimensions in mm pcb layout
Components device side			
RJ45 jacks Cat. 5			
Solder variant SMD, 90° angled	09 45 551 1100 ¹⁾ 09 45 551 1110 ²⁾		
Solder variant overmolded, 90° angled	09 45 551 1102 ¹⁾		
Solder variant overmolded, straight	09 45 551 1103 ³⁾		

1) Packaging: Blister à 120 pieces
2) Packaging: Tape & Reel à 130 pieces
3) Packaging: Tape & Reel à 80 pieces



HARTING RJ Industrial® RJ45 jacks with transformer

Advantages

- Compact design
- Integrated optical fibres
- Excellent EMC behaviour due to integrated transformers and filters for 10/100 Mbit or 1 Gbit Ethernet
- SMC compatible
- Versions from 10/100 Mbit up to 10 Gbit Ethernet and PoE
- Usable for IP65 / IP67 device integration with HARTING PushPull and Han® 3 A RJ45

Technical characteristics

Mating face	RJ45 acc. to IEC 60603-7
Number of contacts	8
Degree of protection	IP20
Rated voltage	30 V DC
Rated current	8 mA DC
Mating cycles	min. 750
Temperature range	-25 °C ... +70 °C

Identification	Part number	Drawing	Dimensions in mm
----------------	-------------	---------	------------------

Components device side

RJ45 jack with transformer (low profile)

90° angled, THT
10/100 Mbit Ethernet

Schematic:

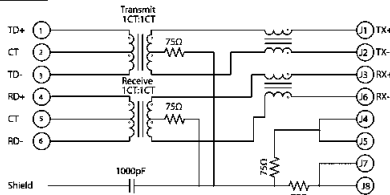

10/100 Mbit Ethernet and PoE

09 45 551 1150¹⁾

09 45 551 1151¹⁾

90° angled, THT
1 Gbit Ethernet

Schematic:

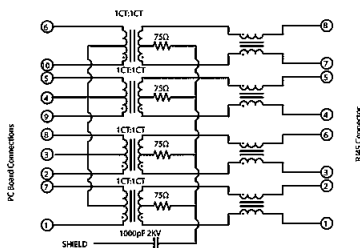

1 Gbit Ethernet and PoE

09 45 551 1540¹⁾

09 45 551 1541¹⁾

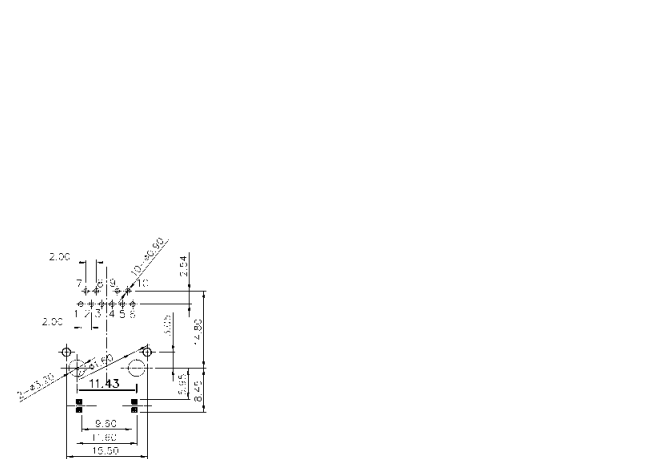
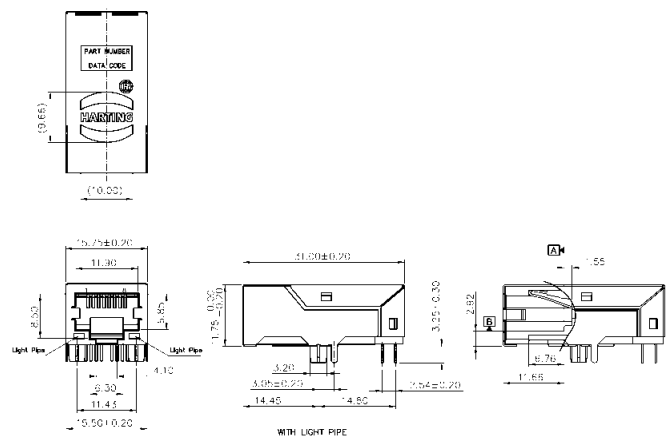

Customer specific versions on request

¹⁾ Packaging: Blister à 56 pieces



HARTING PushPull Technology acc. to IEC 61 076-3-106 variant 4
RJ45-panel feed-throughs and accessories

Advantages

- Small, space-saving PushPull Interfaces in IP65 / IP67
- Easy handling of RJ45 patch cords in switch cabinets or sets
- Mounting to casings

Technical characteristics

Locking	PushPull Technology acc. to IEC 61 076-3-106 variant 4
Transmission rate cat. 5 versions	10/100/1000 Mbit/s
Transmission rate cat. 6 versions	10/100 Mbit/s / 1/10 Gbit/s
Shielding	fully shielded, 360° shielding contact
Mating cycles	min. 750
Degree of protection	IP65 / IP67
Temperature range	-40 °C ... +70 °C
Housing material	Plastic, black Zinc die-cast, shining
Flammability acc. to UL 94	V0 UL approval (E102079)

Identification	Part number	Drawing	Dimensions in mm
Panel feed-through set category of transmission Cat. 5 incl. housing bulkhead mounting EasyInstall with integrated seal, 2 x RJ45-jack board drillings for M3 incl. housing bulkhead mounting Compact, flat seal, 2 x RJ45-jack board drillings for M2.5	09 45 245 1130 09 45 295 1130 (metal version) 09 45 245 1102		
Panel feed-through set category of transmission Cat. 6 incl. housing bulkhead mounting EasyInstall with integrated seal, 2 x RJ45-jack board drillings for M3 incl. housing bulkhead mounting Compact, with integrated seal, 2 x RJ45-jack	09 45 245 1590 09 45 245 1560		

Panel cut outs see page 02.04



HARTING PushPull Technology acc. to IEC 61 076-3-106 variant 4 RJ45-connector

Advantages

- Ethernet connector based on RJ45
- Fully shielded, 360° shielding contact
- Field-assembly connector with IDC contacts (Cat. 5 versions) or piercing contacts (Cat. 6_A versions)

Technical characteristics

Locking	PushPull Technology acc. to IEC 61076-3-106 variant 4
Degree of protection	IP65 / IP67
Mating face	RJ45 acc. to IEC 60603-7
Cable diameter	4.9 ... 8.6 mm
Termination cross section	
Cat. 5	AWG 24/7 ... AWG 22/7 (stranded) AWG 23/1 ... AWG 22/1 (solid)
Cat. 6 _A	AWG 24/7 ... AWG 28/7 (stranded)
Mating cycles	min. 750
Temperature range	-40 °C ... +70 °C
Housing material	Plastic, black Zinc die-cast, shining
Flammability acc. to UL 94	V0
	UL approval (E102079)

Identification	Part number	Drawing	Dimensions in mm
<p>Connector, 4-poles Cat. 5</p> <p>incl. housing with RJ45 connector, shielding and cable gland</p>	<p>09 45 145 1100 09 45 195 1100 (metal version)</p>		
<p>Connector, 8-poles Cat. 6_A</p> <p>incl. housing with RJ45 connector, shielding and cable gland</p>	<p>09 45 145 1520 09 45 145 1520 XL¹⁾ 09 45 195 1520 (metal version)</p>		
<p>suitable assembly tool</p>	<p>09 45 800 0520</p>		

¹⁾ Packaging with 100 sets



HARTING PushPull RJ45 – bulkhead

Advantages

- Small, space-saving PushPull Interfaces in IP65 / IP67
- Easy connection of PushPull RJ45 system cords
- Screwable with 2 x M3 screws

Technical characteristics

Locking	PushPull Technology acc. to IEC 61 076-3-106 variant 4
Number of contacts	8
Transmission category	Cat. 6, performance class EA, suitable for 1/10 Gigabit Ethernet
Transmission rate	10/100 Mbit/s / 1/10 Gbit/s
Shielding	fully shielded, 360° shielding contact
Mating cycles	min. 750
Degree of protection	IP65 / IP67
Temperature range	-40 °C ... +70 °C
Housing material	Plastic, black
Flammability acc. to UL 94	V0
	UL approval (E102079)

Identification

Part number

Drawing

Dimensions in mm

HARTING PushPull RJ45 –
bulkhead

09 45 345 1560

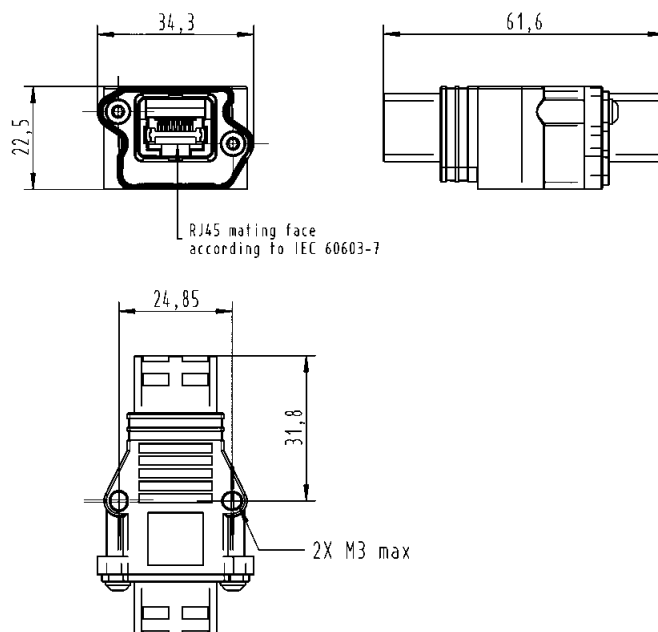



HARTING PushPull Technology acc. to IEC 61 076-3-106 variant 4 RJ45-connector

Advantages

- Ethernet connector based on RJ45
- Fully shielded, 360° shielding contact
- Field-assembly connector with IDC contacts
- Category of transmission: Cat. 6 / class E_A suitable for 1/10 Gbit Ethernet

Technical characteristics

Locking	PushPull Technology acc. to IEC 61076-3-106 variant 4
Mating face	RJ45 acc. to IEC 60603-7
Cable diameter	4.9 ... 8.6 mm
Termination cross section	AWG 27/7 ... AWG 22/7 (stranded) AWG 24/1 ... AWG 22/1 (solid)
Conductor diameter	max. 1.6 mm (incl. insulation)
Mating cycles	min. 750
Degree of protection	IP65 / IP67
Temperature range	-40 °C ... +70 °C
Housing material	Plastic, black Zinc die-cast, shining
Flammability acc. to UL 94	V0
	UL approval (E102079)

Identification

Part number

Drawing

Dimensions in mm

Connector, 8-poles
Cat. 6

incl. housing with RJ45 connector,
shielding and cable gland

09 45 145 1560
09 45 145 1560 XL¹⁾
09 45 195 1560
(metal version)

Colour clips

for colour coding the HARTING
PushPull connectors

White	09 45 840 0011
Yellow	09 45 840 0013
Red	09 45 840 0017
Blue	09 45 840 0018
Green	09 45 840 0019

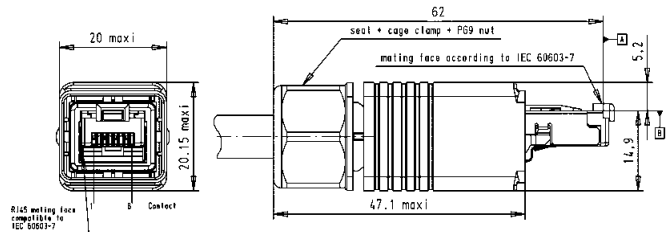



HARTING PushPull type acc. to IEC 61076-3-106 variant 4
LC duplex panel feed-through and connector

Advantages

- Optical PushPull connector based on LC with small form factor (requires 50 % compared to SC and ST)
- EasyInstall and Compact panel feed-through for simple device integration
- Optical module with inserts acc. to IEC 61754-20
- One-piece LC body assures high mechanical stability
- A & B parts identification for Duplex according TIA 568 standard

Technical characteristics

Locking	PushPull Technology acc. to IEC 61076-3-106 variant 4
Degree of protection	IP65 / IP67
Mating face	LC acc. to IEC 61754-20
Cable diameter	5.8 ... 7.2 mm
Mating cycles	min. 200
Temperature range	-40 °C ... +70 °C
Housing material	Plastic, black Zinc die-cast, shining
Flammability acc. to UL 94	V0

Identification	Part number	Drawing	Dimensions in mm
HARTING PushPull LC duplex			
Cable side			
Multimode GOF	09 57 402 0500 000		
	09 57 409 0500 000 (metal version)		
Singlemode GOF	09 57 402 0501 000		
	09 57 409 0501 000 (metal version)		
Device side EasyInstall version			
Multimode GOF	09 57 441 0500 000		
	09 57 468 0500 000 (metal version)		
Singlemode GOF	09 57 441 0501 000		
	09 57 468 0501 000 (metal version)		
Device side Compact version			
Multimode GOF	09 57 442 0502 001		
Singlemode GOF	09 57 442 0503 001		

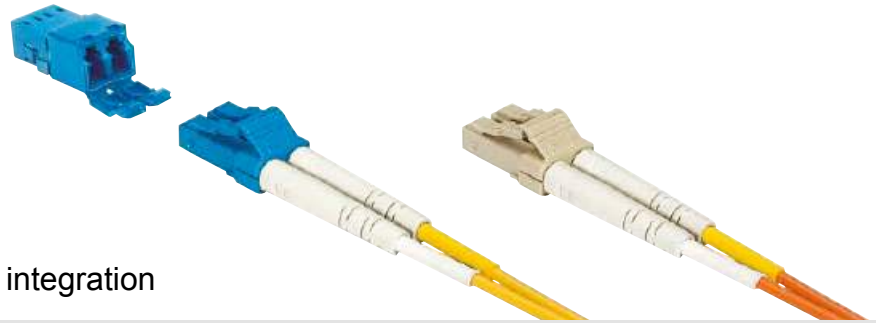

LC duplex IP20 adapter for device integration

Advantages

- Small form factor requires 50 % (compared to SC and ST)
- Compact, space-saving design
- High packing density
- A & B parts identification according TIA 568 standard
- Complement adapter for IP67 connector on device side

Technical characteristics

Degree of protection	IP20
Mating interface	LC duplex with two fibres
Temperature range	-40 °C ... +70 °C

Identification	Part number	Drawing	Dimensions in mm															
Device side																		
Adapter																		
Multimode GOF	09 57 400 0003 000																	
Singlemode GOF	09 57 400 0004 000																	
Connector LC duplex																		
Multimode GOF	09 57 400 0001 000		<table border="1"> <thead> <tr> <th></th> <th>min.</th> <th>max.</th> </tr> </thead> <tbody> <tr> <td>G</td> <td>26.60</td> <td>26.80</td> </tr> <tr> <td>H</td> <td>9.35</td> <td>9.45</td> </tr> <tr> <td>J</td> <td>12.80</td> <td>12.90</td> </tr> <tr> <td>K</td> <td>15.24</td> <td>15.34</td> </tr> </tbody> </table>		min.	max.	G	26.60	26.80	H	9.35	9.45	J	12.80	12.90	K	15.24	15.34
	min.			max.														
G	26.60	26.80																
H	9.35	9.45																
J	12.80	12.90																
K	15.24	15.34																
Singlemode GOF	09 57 400 0002 000																	



Identification	Part number	Drawing	Dimensions in mm
<p>Fibre optic cable, double ended, multi mode, 62.5 µm overmolded</p> <p>Length: a = 1 m</p> <p>a = 5 m</p> <p>a = 10 m</p> <p>a = 20 m</p> <p>a = 40 m</p> <p>a = 50 m</p> <p>a = 60 m</p> <p>a = 100 m</p> <p>a = 300 m</p>	<p>33 58 231 0010 016</p> <p>33 58 231 0050 016</p> <p>33 58 231 0100 016</p> <p>33 58 231 0200 016</p> <p>33 58 231 0400 016</p> <p>33 58 231 0500 016</p> <p>33 58 231 0600 016</p> <p>33 58 231 1000 016</p> <p>33 58 231 3000 016</p>	<p>double ended</p> <p>a = length</p>	
<p>Fibre optic breakout cable, multi mode, 62.5 µm</p> <p>Length: 10 m</p> <p>Length: 20 m</p> <p>Length: 100 m</p>	<p>33 58 751 0100 001</p> <p>33 58 751 0200 001</p> <p>33 58 751 1000 001</p>	<p>PUR jacket</p> <p>2-fibre multi mode 62.5 µm</p> <p>Outer diameter: 7 mm</p> <p>Min. bending radius: 10.5 cm</p> <p>Installation: 7.0 cm</p> <p>Operating: 7.0 cm</p>	

Further cable lengths are available on request

HARTING PushPull LC duplex



Identification

Part number

Drawing

Dimensions in mm

Fibre optic cable, double ended, multi mode, 50 µm overmolded

Length: a =	1 m	33 58 231 0010 017
a =	5 m	33 58 231 0050 017
a =	10 m	33 58 231 0100 017
a =	20 m	33 58 231 0200 017
a =	40 m	33 58 231 0400 017
a =	50 m	33 58 231 0500 017
a =	60 m	33 58 231 0600 017
a =	100 m	33 58 231 1000 017
a =	300 m	33 58 231 3000 017

double ended

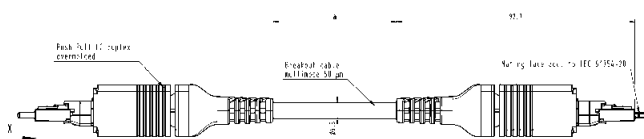

a = length

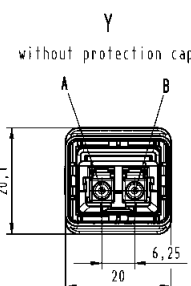
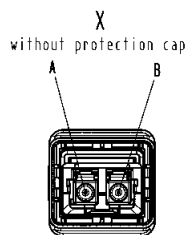

Loading-Plan

A — blue B
B — orange A

Fibre optic breakout cable, multi mode

Length: 10 m	33 58 751 0100 003
Length: 20 m	33 58 751 0200 003
Length: 100 m	33 58 751 1000 003



PUR jacket
2-fibre multi mode 50 µm
Outer diameter: 6.5 mm
Min. bending radius:
Installation: 10.4 cm
Operating: 5.2 cm



Identification	Part number	Drawing	Dimensions in mm
<p>Fibre optic cable, double ended, single mode overmolded</p> <p>Length: a = 1 m</p> <p>a = 5 m</p> <p>a = 10 m</p> <p>a = 20 m</p> <p>a = 40 m</p> <p>a = 50 m</p> <p>a = 60 m</p> <p>a = 100 m</p> <p>a = 300 m</p>	<p>33 58 231 0010 015</p> <p>33 58 231 0050 015</p> <p>33 58 231 0100 015</p> <p>33 58 231 0200 015</p> <p>33 58 231 0400 015</p> <p>33 58 231 0500 015</p> <p>33 58 231 0600 015</p> <p>33 58 231 1000 015</p> <p>33 58 231 3000 015</p>	<p>double ended</p> <p>a = length</p> <p>without protection cap</p> <p>without protection cap</p> <p>Loading-Plan</p> <p>A blue B</p> <p>B orange A</p>	
<p>Fibre optic breakout cable, single mode</p> <p>Length: 10 m</p> <p>Length: 20 m</p> <p>Length: 100 m</p>	<p>33 58 751 0100 002</p> <p>33 58 751 0200 002</p> <p>33 58 751 1000 002</p>	<p>PUR jacket</p> <p>2-fibre single mode</p> <p>Outer diameter: 6.5 mm</p> <p>Min. bending radius: 10.4 cm</p> <p>Installation: 10.4 cm</p> <p>Operating: 5.2 cm</p>	

Further cable lengths are available on request



A large grid area for taking notes, consisting of a grid of small squares. The grid is composed of solid lines forming the outer border and dotted lines forming the inner grid cells.



HARTING PushPull Hybrid
type acc. to IEC 61076-3-106 variant 4

Advantages

HARTING PushPull Hybrid

In the future all new machine generations will be equipped with Fast Ethernet, no matter if PROFINET, Ethernet/IP, Powerlink, Ethercat, Varan or other Ethernetprofiles.

With the change of the communication technology also the possibility is offered of simplifying the machine installation and of introducing an innovative Hybrid installation concept. This simplification will unite by data and 24 V (5 A)-supply in a Hybrid cable, at least with the space requirement of a M12-connector.

For this new installation solution HARTING with the HARTING PushPull Hybrid offers the trend-setting installation technology.

Everything is halved: the number of pluggings, the number of cables and the space requirement for the connection technology. Everything becomes simpler: the installation, attaching and safe plugging.

The Hybrid connectors were developed particular under the criteria of simple attaching in the field and the particular safe data communication with the patented omega screen concept. As contacts D-Sub and HDD Sub contacts worked world-wide are used. This socket pin contact system ensures highest reliability and optimal shock and vibration stability.

With the optional available coding pins 6 different codings can be realized.

Technical characteristics

Advantages

- Compact, space-saving design
- Very compact housing with high degree of protection
- Polarisation with nose
- Sixfold codable

Typical application areas

- Factory and building automation
- Industrial electronics
- Telecommunication and wireless networks
- Transportation
- Industrial monitoring and camera systems
- Lighting and display technology
- Access control systems

Recommended pin assignment

- Power contacts

Contact	Function	Conductor colour
1	V +	Red
2	Ground	Brown
3	V + (switched)	Yellow

- Data contacts

Contact	Signal	Function	Conductor colour
4	RD -	Receiver Data -	Blue
5	RD +	Receiver Data +	White
6	TD -	Transmission Data -	Orange
7	TD +	Transmission Data +	Yellow



Structure Hybrid cable

Data: 4x AWG26/7

Power: 3x AWG20/7



HARTING PushPull Hybrid, type acc. to IEC 61076-3-106 variant 4 device side

Advantages

- Combined data- and power-supply up to 5 A/48 V included to one connector
- HARTING PushPull technology
- Compact design
- High packing density
- Sixfold codable
- Suitable for all Fast-Ethernet variants

Technical characteristics

Locking	PushPull Technology acc. to IEC 61076-3-106 variant 4
Degree of protection	IP65 / IP67
Termination	Solder pins
Transmission performance	Category 5 / Class D up to 100 MHz acc. to ISO/IEC 11801:2002, EN ISO 50 173-1
Transmission rate	10 / 100 Mbit/s
Number of contacts	Data: 4, shielded (Ethernet) Power: 3, (5 A / 48 V)
Housing material	Plastic, black
Flammability acc. to UL 94	V0

Identification	Part number	Drawing	Dimensions in mm
Components device side			
Set straight HARTING PushPull Hybrid housing bulkhead mounting and pcs female shielded, IP65 / IP67, black, 180° straight	09 45 245 1300		
Set angled HARTING PushPull Hybrid housing bulkhead mounting and pcs female shielded, IP65 / IP67, black, 90° angled	09 45 245 1310		
Female insert PCB jack shielded 180° straight PCB jack shielded 90° angled	09 45 545 1300 09 45 545 1305		
Housing bulkhead mounting for female insert straight for female insert angled	09 45 545 1320 09 45 545 1325		
Panel feed-through 1 x Hybrid female IP65 / IP67 on 1 x RJ45 female and 3 pcb clamps, board drillings for M2.5	09 45 245 1320		



HARTING PushPull Hybrid, type acc. to IEC 61076-3-106 variant 4
Hybrid connector

Advantages

- Combined data- and power-supply up to 5 A / 48 V included to one connector
- HARTING PushPull technology
- Compact design
- High packing density
- Sixfold condable
- Suitable for all Fast-Ethernet variants

Technical characteristics

Locking	PushPull Technology acc. to IEC 61076-3-106 variant 4
Degree of protection	IP65 / IP67
Termination	Crimp
Cable diameter	AWG 26 for Ethernet AWG 20 for Power
Transmission performance	Category 5 / Class D up to 100 MHz acc. to ISO/IEC 11801:2002, EN ISO 50173-1
Number of contacts	Data: 4, shielded (Ethernet) Power: 3, (5 A / 48 V)
Housing material	Plastic, black
Flammability acc. to UL 94	V0

Identification	Part number	Drawing	Dimensions in mm
Connector HARTING PushPull Hybrid connector, IP65/ 67, black, with cable gland and crimp contacts straight	09 45 145 1300		
Accessories – Coding pin set to avoid accidental incorrect mating a coding system is required. This coding pins are inserted without loss of contact.	09 45 845 1300		
Tools Crimping tool for data contacts	09 99 000 0535		
Crimping tool for power contacts	09 99 000 0175		
Insertion and removal tool for data contacts	09 99 000 0513		
for power contacts	09 99 000 0171		



HARTING PushPull Hybrid, type acc. to IEC 61076-3-106 variant 4 overmoulded Hybrid system cables

Advantages

- Combined data- and power-supply up to 5 A / 48 V included to one connector
- HARTING PushPull technology
- Robust design, suitable for industrial applications
- High packing density
- Sixfold codable
- Suitable for all Fast-Ethernet variants

Technical characteristics

Cable construction:	Twisted Pair shielded + 3 Power cables
Core structure	Data: 4x AWG 26/7 Power: 3x AWG 20/7
Transmission performance	Category 5 / Class D up to 100 MHz acc. to ISO/IEC 11801:2002, EN ISO 50173-1
Sheath material	FRNC
Cable-outer diameter	∅ (7.0 ±0.4) mm
Shielding	Shielding foil and shielding braid
Temperature range	-40 °C ... +80 °C
Colour	black

Identification	Part number	Drawing	Dimensions in mm
----------------	-------------	---------	------------------

System cables 2x HARTING PushPull Hybrid

Length	0.5 m	09 47 616 1005
	0.8 m	09 47 616 1008
	1 m	09 47 616 1010
	2 m	09 47 616 1020
	3 m	09 47 616 1030
	5 m	09 47 616 1050
	10 m	09 47 616 1100
	20 m	09 47 616 1200

Hybrid cable

ring	20 m	09 45 600 0331
ring	50 m	09 45 600 0341
ring	100 m	09 45 600 0301
reel	500 m	09 45 600 0321



Structure Hybrid cable



HARTING PushPull, type acc. to IEC 61 076-3-106 variant 4
10-poles 50 V / 5 A

Features

- HARTING PushPull technology
- For the transmission of analog, low voltage and bus signals
- Fully shielded
- 10 contacts
- Touch-proof
- Easy and fast cable installation

Technical characteristics

Locking	PushPull technology acc. to IEC 61 076-3-106 variant 4
Degree of protection	IP65 / IP67
Mating face	acc. to IEC/PAS 61076-3-11x
Number of contacts	10
Electrical data acc. to DIN EN 61984	5 A 50 V 1.5 kV 3
Contact resistance	10 mΩ
Termination	Crimp or solder
Conductor cross section	AWG 24 ... 18; 0.25 ... 0.82 mm ²
Conductor diameter	max. 2.1 mm
Outer cable diameter	4.9 ... 8.6 mm
Shielding	Fully shielded, 360° shielding contact
Mating cycles	min. 500
Temperature range	-40 °C ... +70 °C
Housing material	Plastic, black
Flammability acc. to UL 94	V0

Identification	Part number	Drawing	Dimensions in mm
<p>HARTING PushPull Signal</p> <p>Connector set 10-poles incl. plastic housing and female insert</p> <p>Order D-Sub crimp female contacts separately</p>	09 45 145 9010	<p>Gesamtlänge montiert ca. 61 <i>total length assembled of approx. 61</i></p>	
<p>D-Sub crimp contacts for cable side</p> <p>female, turned AWG 24-20; 0.25 - 0.52 mm²</p> <p>female, turned AWG 22-18; 0.33 - 0.82 mm²</p> <p>female, stamped AWG 24-20; 0.25 - 0.56 mm²</p>	<p>09 67 000 8476¹⁾</p> <p>09 67 000 3476¹⁾</p> <p>09 67 000 8278²⁾</p>		

¹⁾ To be used with crimp tool 09 99 000 0501. Suitable locator: 09 99 000 0531

²⁾ To be used with crimp tool 09 99 000 0175.

Identification	Part number	Drawing	Dimensions in mm
HARTING PushPull Signal Insert for panel feed-through HIFF, 10-poles incl. male insert Order D-Sub crimp male contacts separately D-Sub crimp contacts for device side	09 45 545 9010		
male, turned AWG 24-20; 0.25-0.52 mm ²	09 67 000 8576 ¹⁾		
male, turned AWG 22-18; 0.33-0.82 mm ²	09 67 000 3576 ¹⁾		
male, stamped AWG 24-20; 0.25-0.56 mm ²	09 67 000 8178 ²⁾		
HARTING PushPull suitable housing, bulkhead mounting, plastic EasyInstall	09 45 545 0032		
Compact	09 45 545 0028		
HARTING PushPull Signal solder jack angled suitable housings, bulkhead mounting with fixing clip	09 45 545 9011		
without fixing clip	09 45 545 0029		
without fixing clip	09 45 545 0033		
HARTING PushPull Signal solder jack straight suitable housing, bulkhead mounting	09 45 545 9012		
	09 45 545 0027		

¹⁾ To be used with crimp tool 09 99 000 0501. Suitable locator: 09 99 000 0531

²⁾ To be used with crimp tool 09 99 000 0175.



HARTING PushPull USB
Components device side and panel feed-throughs

Advantages

- HARTING PushPull technology
- Compact, space-saving design for the device integration of USB jacks
- USB 2.0 and 3.0 compatible

Technical characteristics

Mating face	USB 2.0 type B and USB 2.0 / 3.0 type A
Number of contacts	USB 2.0: 4 and USB 3.0: 9
Degree of protection	IP65 / IP67
Mating cycles	min. 750
Temperature range	-40 °C ... +70 °C

Identification	Part number	Drawing	Dimensions in mm
Components device side USB 2.0 type B Solder jack, angled 90°, THT	09 45 541 1900		
Adapter PCB USB 2.0 type A Jack to pin header Jack to solder points	09 45 541 1902 09 45 541 1903		
Adapter PCB USB 2.0 type B Jack to jack Type B-B Type B-B, 90° Type A-B	09 45 541 1906 09 45 541 1907 09 45 541 1910		

All solder jacks and adapter PCB's are suitable for the HARTING PushPull bulkhead mounting housings 09 45 545 0029 / ... 0030 / ... 0031 / ... 0033 (see page 02.04)

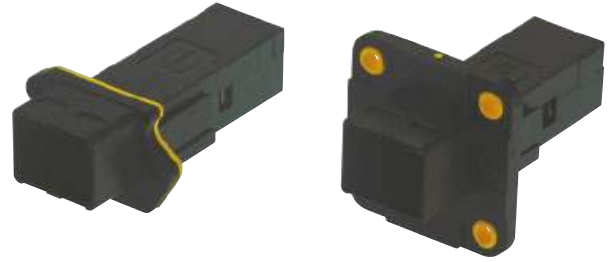

HARTING PushPull USB Panel feed-throughs

Advantages

- HARTING PushPull technology
- Compact, space-saving design for the device integration of USB jacks
- USB 2.0 and 3.0 compatible

Technical characteristics

Mating face	USB 2.0 / 3.0 type A
Number of contacts	USB 2.0: 4 and USB 3.0: 9
Degree of protection	IP65 / IP67
Mating cycles	min. 750
Temperature range	-40 °C ... +70 °C

Identification	Part number	Drawing	Dimensions in mm
Panel feed-throughs EasyInstall style USB 2.0 type A 2 x jack USB 3.0 type A 2 x jack	09 45 245 1903 09 45 245 1905		
Compact style USB 2.0 type A 2 x jack USB 3.0 type A 2 x jack	09 45 245 1902 09 45 245 1904		



HARTING PushPull USB System cables

Advantages

- HARTING PushPull technology
- Compact, space-saving design for the device integration of USB jacks
- USB 2.0 and 3.0 compatible
- Fully shielded, 360° shielding contact
- Robust design, suitable for industrial applications

Technical characteristics

Mating face	USB 2.0 type B and USB 2.0 / 3.0 type A
Number of contacts	USB 2.0: 4 and USB 3.0: 9
Degree of protection	IP65 / IP67
Mating cycles	min. 750
Temperature range	-40 °C ... +70 °C

Identification	Part number	Drawing	Dimensions in mm
System cables 2 x PushPull USB			
USB 2.0 type B-B	Length: 1.5 m 5.0 m	09 45 145 3902 09 45 145 3905	
USB 2.0 type A-A	Length: 1.5 m 5.0 m	09 45 145 1902 09 45 145 1905	
USB 3.0 type A-A	Length: 1.5 m 5.0 m	09 45 145 2902 09 45 145 2905	
System cables 1 x PushPull USB 1 x IP20 USB			
USB 2.0 type B-B	Length: 1.5 m 5.0 m	09 45 145 3912 09 45 145 3915	
USB 2.0 type A-A	Length: 1.5 m 5.0 m	09 45 145 1912 09 45 145 1915	
USB 3.0 type A-A	Length: 1.5 m 5.0 m	09 45 145 2912 09 45 145 2915	
Other types and lengths on request			

HARTING offers with the HARTING PushPull Power connector an universal solution for the power supply in compact and robust applications. It is in its element wherever small dimensions are combined with a high protection class.

The connector is available in a 4-pole 48 V and a 2-pole 250 V version. The power contacts can carry up to 12 resp. 16 A each (see deratings). In spite of this high current carrying capacity the connector gets by with minimal dimensions and fulfils the industrial requirements for clearances and creepage distances at the same time (pollution degree 3 and overvoltage category III).

Additionally the HARTING PushPull Power connector offers the protection class of IP67 and 65. Beside numerous industrial use cases it is thereby suited for diverse applications in the fields of transportation and telecommunication.

The cable side of the HARTING PushPull Power is terminated with crimping technology. For the receptacle several solutions with different termination technologies are offered.

- Regulations**
- VDE 0110
 - DIN EN 61984

- Advantages**
- Minimum space requirements in spite of high current carrying capacity
 - Very compact housing in a high protection class
 - Protection against contact on plug AND receptacle side enables an easy and safe installation
 - For low voltage (48 V) and for power supply (250 V) available
 - Codeable without losing contacts
 - Different termination technologies for individual device integration

- Typical application areas**
- Factory and building automation
 - Industrial electronics
 - Telecommunication and wireless networks
 - Transportation
 - Industrial monitoring and camera systems
 - Lighting and display technology
 - Access control systems

Current carrying capacity

The current carrying capacity is determined in tests which are conducted on the basis of the DIN IEC 60512-5-2. The current carrying capacity is limited by the thermal properties of materials which are used for inserts as well as by the insulating materials. These components have a limiting temperature which should not be exceeded.

Example of a current capacity curve

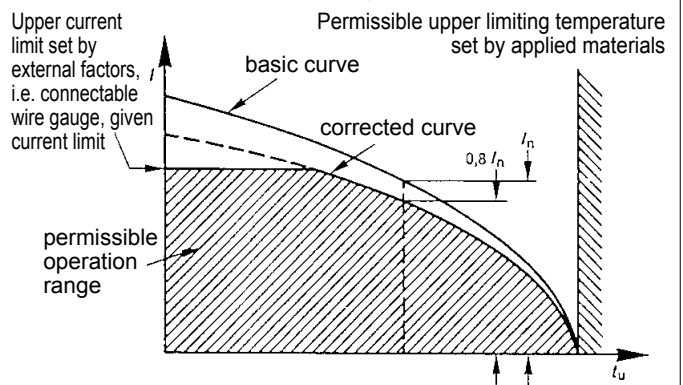

Derating-Diagram for low voltage, 48 V; 4x 12 A

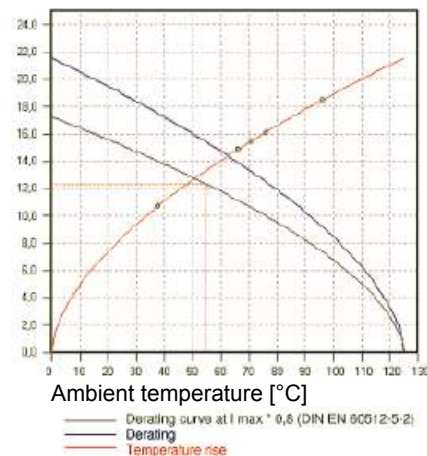

Derating-Diagram for power supply, 250 V; 2x 16 A

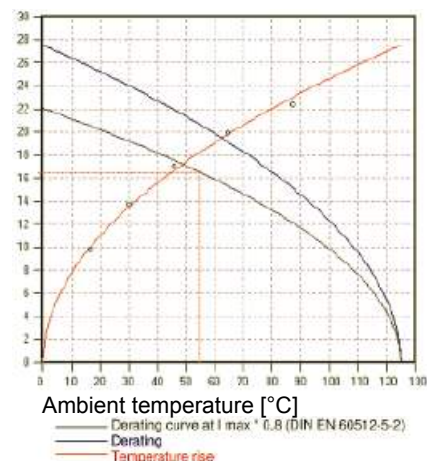



HARTING PushPull Power 4/0, type acc. to IEC 61076-3-106 variant 4
panel feed-throughs 4-poles 48 V / 12 A

Advantages

- Power connectors for devices
- EasyInstall and Compact panel feed-through and females for simple device integration
- Compact, space-saving design
- Touch-proof according to IEC DIN EN 60 529
- Polarisation with nose
- Device side: female with cable cage, crimp or solder termination
- 4 different coding variants without loss of contact

Technical characteristics

Locking	PushPull Technology acc. to IEC 61076-3-106 variant 4
Degree of protection	IP65 / IP67
Number of contacts	4
Electrical data acc. to EN 61984	12 A 48 V 1.5 kV 3
Termination	Crimp
Termination cross section	0.75 - 2.5 mm ² (AWG 20 - 12) stranded
Termination	Solder pins
Termination diameter	1.6 mm
Termination	Cable cage
Termination cross section	0.75 - 2.5 mm ² (AWG 20 - 12) stranded
Mating cycles	min. 750
Temperature range	-40 °C ... +70 °C
Housing material	Plastic, black
Flammability acc. to UL 94	V0

Identification	Part number	Drawing	Dimensions in mm
Panel feed-through set			
Housing bulkhead mounting EasyInstall with 4 turned female contacts and insulation body with crimp termination for 1.5 mm ² with solder termination, 90° angled with cage clamp terminal on pcb	09 46 245 4430 09 46 295 4430 ¹⁾ 09 46 245 4030 09 46 245 4031 09 46 295 4031 ¹⁾		
Housing bulkhead mounting Compact with 4 turned female contacts and insulation body with crimp termination for 1.5 mm ² with solder termination, 90° angled with cage clamp terminal on pcb	09 46 245 4400 09 46 245 4000 09 46 245 4001		
Power-female with solder termination 4-poles, 48 V / 12 A, 90° angled 4-poles, 48 V / 12 A, straight	09 46 500 4400 ²⁾ 09 46 500 4402 ³⁾		
Power-female with crimp termination	09 46 500 4401		

Panel cut outs see page 02.04

- 1) Metal version (without contacts)
- 2) Suitable housings: 09 45 545 0029 / ... 0030 / ... 0031
- 3) Suitable housing: 09 45 545 0027



HARTING PushPull Power 4/0, type acc. to IEC 61076-3-106 variant 4 connector 4-poles 48 V / 12 A

Advantages

- Power connectors for devices
- EasyInstall panel feed-through for simple device integration
- Compact, space-saving design
- Touch-proof according to IEC DIN EN 60529
- Polarisation with nose
- Cable side: Male with crimp termination
- 4 different coding variants without loss of contact

Technical characteristics

Locking	PushPull Technology acc. to IEC 61076-3-106 variant 4
Degree of protection	IP65 / IP67
Number of contacts	4
Electrical data acc. to EN 61984	12 A 48 V 1.5 kV 3
Cable diameter	4.9 ... 8.6 mm
Termination	Crimp
Termination cross section	0.75 - 2.5 mm ² (AWG 20 - 12) stranded
Mating cycles	min. 750
Temperature range	-40 °C ... +70 °C
Housing material	Plastic, black
Flammability acc. to UL 94	V0

Identification

Part number

Drawing

Dimensions in mm

Connector set

incl. 4 turned crimp contacts (male)
for 1.5 mm², insulation body, housing,
cable gland

09 46 145 4400
09 46 195 4400¹⁾

Connector set

without contacts

09 46 145 4401

Accessories – crimp contacts male

- 0.75 mm² (AWG 20 - 18)
- 1.0 mm² (AWG 18)
- 1.5 mm² (AWG 16 - 14)
- 2.5 mm² (AWG 12)

09 46 500 0403
09 46 500 0407
09 46 500 0401
09 46 500 0405

Accessories – crimp contacts female

- 0.75 mm² (AWG 20 - 18)
- 1.0 mm² (AWG 18)
- 1.5 mm² (AWG 16 - 14)
- 2.5 mm² (AWG 12)

09 46 500 0404
09 46 500 0408
09 46 500 0402
09 46 500 0406

Accessories – Coding pin set

to avoid accidental incorrect mating
a coding system is required.
This coding pins are inserted without
loss of contact.

09 46 840 0000

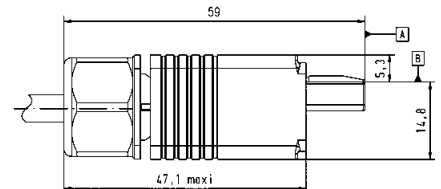
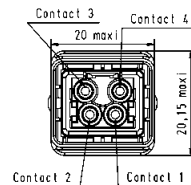

¹⁾ Metal version (without contacts)



HARTING PushPull Power 2/0, type acc. to IEC 61076-3-106 variant 4 panel feed-through and connector, 3-poles, 250 V / 16 A

Advantages

- Power connectors for devices
- EasyInstall panel feed-through for simple device integration
- Compact, space-saving design
- Touch-proof according to IEC DIN EN 60529
- Polarisation with nose
- Cable side: Male with crimp termination
- Device side: female with crimp termination
- 4 different coding variants without loss of contact

Technical characteristics

Locking	PushPull Technology acc. to IEC 61076-3-106 variant 4
Degree of protection	IP65 / IP67
Number of contacts	2 + PE
Electrical data acc. to EN 61984	16 A 250 V 4 kV 3
Cable diameter	4.9 ... 8.6 mm
Termination	Crimp
Termination cross section	0.75 - 2.5 mm ² (AWG 20 - 12) stranded
Mating cycles	min. 750
Temperature range	-40 °C ... +70 °C
Housing material	Plastic, black
Flammability acc. to UL 94	V0

Identification	Part number	Drawing	Dimensions in mm
HARTING PushPull Power 2/0			
Panel feed-through set incl. 3 turned crimp contacts (female) for 1.5 mm ² , insulation body (black), housing bulkhead mounting EasyInstall	09 46 245 3430		
Panel feed-through set incl. 3 turned contacts (female) for 1.5 mm ² , insulation body (black), housing bulkhead mounting, with crimp termination	09 46 245 3410		
Power-female with solder termination¹⁾ angled	09 46 500 3400		
Power-female with crimp termination without contacts	09 46 500 3401		
Connector set incl. 3 turned crimp contacts (male) for 1.5 mm ² , insulation body (black), housing, cable gland	09 46 145 3410		
Connector set without contacts	09 46 145 3411		
Coding pin set to avoid accidental incorrect mating a coding system is required. This coding pins are inserted without loss of contact.	09 46 840 0000		

Crimp contacts see page 02.28

Panel cut outs see page 02.04

¹⁾ Suitable housings: 09 45 545 0029 / ... 0031

Identification

Part number

HARTING PushPull Power
8-indent crimping tool incl. positioner

09 46 800 0000

Locator HARTING PushPull Power
contacts for Buchanan crimping tool
(09 99 000 0001)

09 46 800 0010



For wire gauges
0.08 ... 4.0 mm²
(AWG 28 ... 12).

Insertion tool

09 46 800 0099

Extraction tool

09 46 800 0098



For an easy insertion and
extraction of the male and
female crimp contacts into /
out of the insulator body.

Crimp connection

A perfect crimp connection is gastight, therefore corrosion free and amounts to a cold weld of the parts being connected. For this reason, major features in achieving high quality crimp connections are the design of the contact crimping parts and of course the crimping tool itself. Wires to be connected must be carefully matched with the correct size of crimp contacts. If these basic requirements are met, users will be assured of highly reliable connections with low contact resistance and high resistance to corrosive attack.

The economic and technical advantages are:

- Constant contact resistance as a result of precisely repeated crimp connection quality
- Corrosion free connections as a result of cold weld action
- Pre-preparation of cable forms with crimp contacts fitted
- Optimum cost cable connection

Requirements for crimp connectors are laid down in DIN IEC 60352-2, Amend. 2, as illustrated in the table.

Pull out force of stranded wire

The main criterion to judge the quality of a crimp connection is the retention force achieved by the wire conductor in the terminal section of the contact. DIN IEC 60352, part 2, defines the extraction force in relation to the cross-section of the conductor. When fitted using HARTING crimping tools and subject to their utilization in an approved manner, our crimp connectors comply with the required extraction forces.

Crimping tools

Crimping tools (hand operated or automatic) are carefully designed to produce with high pressure forming parts a symmetrical connection of the crimping part of the contact and the wire being connected with the minimum increase in size at the connection point. The positioner automatically locates the crimp and wire at the correct point in the tool.

A ratchet in the tool performs 2 functions:

- ① It prevents insertion of the crimp into the tool for crimping before the jaws are fully open
- ② It prevents the tool being opened before the crimping action is completed

Identical, perfectly formed, connections can be produced using this crimping system.

Tensile strength of crimped connections

Conductor cross-section		Tensile strength
mm ²	AWG	N
0.08	28	11
0.12	26	15
0.14		18
0.22	24	28
0.25		32
0.32	22	40
0.5	20	60
0.75		85
0.82	18	90
1.0		108
1.3	16	135
1.5		150
2.1	14	200
2.5		230
3.3	12	275
4.0		310

Extract from DIN IEC 60352-2, Amend. 2, Table IV



Crimp-cross section
HARTING crimp profile

Identification	Part number	Drawing	Dimensions in mm
Transport protection for device side IP40	09 45 845 0003		
Protection cover for device side IP65 / IP67			
Version with passive locking without cord	09 45 845 0009 024		
Version with passive locking with plastic cord for fixing screw M3	09 45 845 0009		
Version with passive locking with nylon cord for fixing screw M2.5 / M3	09 45 845 0011 024		
Version with active locking without cord	09 45 845 0015		
Version with active locking with plastic cord for fixing screw M3	09 45 845 0014		
Version with active locking with nylon cord for fixing screw M2.5 / M3	09 45 845 0013		
Protection cover for connectors IP65 / IP67	09 45 845 0010		
Security clip for connectors can be sealed and protects against unauthorized unplugging	09 45 845 0020		
Blinding plate to close PushPull Compact panel cuttings	09 45 845 0019		



HARTING PushPull, type acc. to IEC 61 076-3-106 variant 4
cable to cable housing

Features

- HARTING PushPull technology
- Ideal for prototyping
- Can be combined with panel feed-throughs for power, data and signal

Technical characteristics

Locking	PushPull technology acc. to IEC 61076-3-106 variant 4
Degree of protection	IP65 / IP67
Outer cable diameter	6.5 ... 9.5 mm
Mating cycles	min. 750
Temperature range	-40 °C ... +70 °C
Housing material	Plastic, black
Flammability acc. to UL 94	V0

Identification	Part number	Drawing	Dimensions in mm
HARTING PushPull cable to cable housings, plastic (Order housing bulkhead mounting and insert separately) for outer cable diameter 6.5 ... 9.5 mm	09 45 345 0000	2X M2.5x10 self tapping screws according to EN ISO 7092 	
HARTING PushPull bulkhead housings, plastic (Order housing bulkhead mounting and insert separately)	09 45 345 0001	2X M2.5x10 self tapping screws according to EN ISO 7092 	
Suitable bulkhead housing, plastic for RJ45 / Signal	09 45 545 0028		
Inserts for RJ45 / Signal RJ 45: 8-poles, Cat. 6 / class E _A Ha-Vis preLink® set AWG 22/23 HARTING RJ Industrial® cable jack with IDC termination AWG 22-24, 8-poles AWG 24-28, 8-poles AWG 22-24, 4-poles, Cat. 5	20 82 001 0001 09 45 545 1562 09 45 545 1561 09 45 545 1120		
Signal: 10-poles, 50 V / 5 A*	09 45 545 9010		

* Order D-Sub crimp male contacts separately (see pages 02.19 and 02.20)



Han® PushPull, type acc. to IEC 61 076-3-117 variant 14
Housing bulkhead mounting for device integration and RJ45 jacks

Features

- HARTING PushPull technology
- Compact design
- High packing density
- Device integration via RJ45 PCB connectors

Technical characteristics

Locking	PushPull technology acc. to IEC 61 076-3-117
Degree of protection	IP65 / IP67
Mating face	RJ45 acc. to IEC 60 603-7
Termination type	Jack with solder termination
Mating cycles	min. 750
Temperature range	-40 °C ... +70 °C
Housing material	Plastic, black
Flammability acc. to UL 94	V0

Identification

Part number

Drawing

Dimensions in mm

Components device side

Housing bulkhead mounting plastic

09 35 002 0321

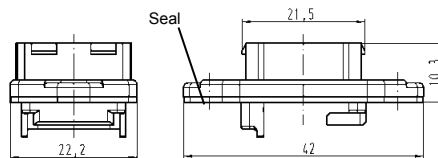

Panel cut out

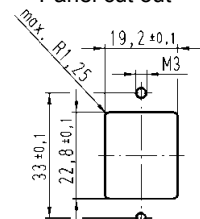

Protection cover IP65 / IP67

09 35 002 5402

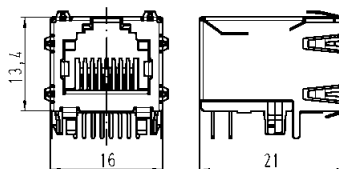

PCB layout

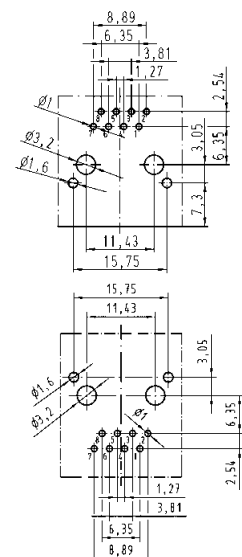

RJ45 jack

Solder variant, 90° angled

09 35 002 2101¹⁾

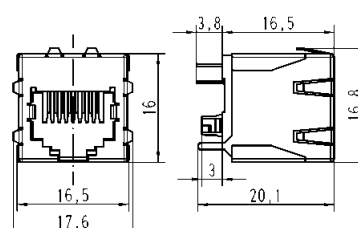

Solder variant, 180° straight

09 35 002 2102²⁾

¹⁾ Packaging: Blister à 90 pieces

²⁾ Packaging: Blister à 100 pieces



PushPull



Han® PushPull, type acc. to IEC 61 076-3-117 variant 14
RJ45 panel feed through

Features

- HARTING PushPull technology
- Compact design
- High packing density
- Device integration via RJ45 PCB connectors

Technical characteristics

Locking	PushPull technology acc. to IEC 61 076-3-117
Degree of protection	IP65 / IP67
Mating face	RJ45 acc. to IEC 60 603-7
Transmission performance	acc. to ISO/IEC 11 801:2002, EN 50 173-1, category 5 / class D up to 100 MHz resp. category 6 / class E _A up to 500 MHz
Transmission rate	10 / 100 Mbit/s and 1 / 10 Gbit/s
Number of contacts	8
Shielding	Fully shielded, 360° shielding contact (Cat. 6)
Mating cycles	min. 750
Temperature range	-40 °C ... +70 °C
Housing material	Plastic, black
Flammability acc. to UL 94	V0

Identification Part number Drawing Dimensions in mm

Han® PushPull RJ45
Panel feed through Cat. 6 including housing and HARTING RJ Industrial® 10G RJ45 bulkhead

09 35 225 0331

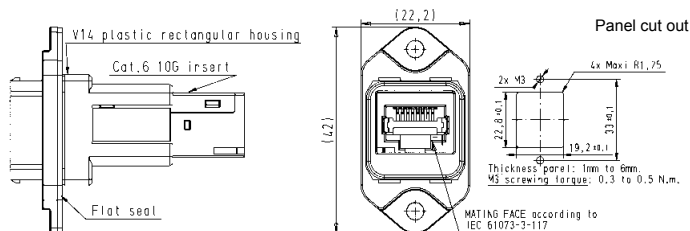

Panel feed through to mount HIFF inserts, e.g. Ha-VIS preLink® RJ45-module
Order inserts separately

09 35 012 0331

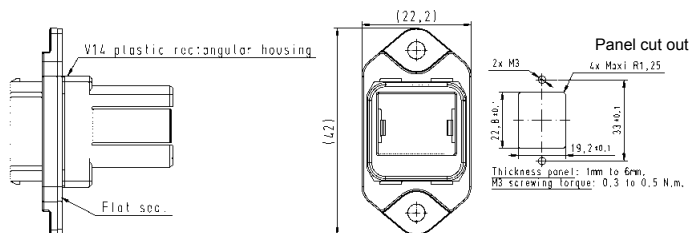

Ha-VIS preLink® set
RJ45 jack AWG 22/23

consists of:

- 1x Ha-VIS preLink® module RJ45 jack
- 1x Ha-VIS preLink® terminal module
- 1x cable tie

20 82 001 0001

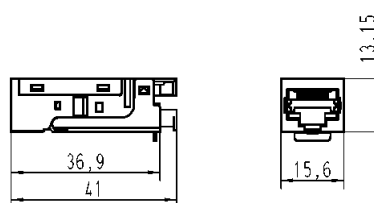

HARTING RJ Industrial®
cable jack IDC

AWG 22-24, 8-poles, Cat. 6

09 45 545 1562

AWG 24-28, 8-poles, Cat. 6

09 45 545 1561

AWG 22-24, 4-poles, Cat. 5

09 45 545 1120



Han® PushPull, type acc. to IEC 61 076-3-117 variant 14 RJ45 connector

Features

- HARTING PushPull technology
- Field-assembly connector with IDC contacts
- Fully shielded

Technical characteristics

Locking	PushPull technology acc. to IEC 61 076-3-117
Degree of protection	IP65 / IP67
Mating face	RJ45 acc. to IEC 60 603-7
Shielding	Fully shielded, 360° shielding contact
Number of contacts	4 respectively 8
Transmission performance	acc. to ISO/IEC 11 801:2002, EN 50 173-1, category 5 / class D up to 100 MHz, category 6 / class E _A up to 500 MHz
Transmission rate	10/100 Mbit/s and 1/10 Gbit/s
Termination for Cat. 5	with IDC contacts, no tools needed / field-assembly
	Conductor cross section AWG 24/7 - 22/7 (stranded) AWG 23/1 - 22/1 (solid)
	Cable diameter 1.6 mm
for Cat. 6	Conductor cross section AWG 22/7 - 27/7 (stranded) AWG 22/1 - 27/1 (solid)
	Cable diameter 1.6 mm
Mating cycles	min. 750
Temperature range	-40 °C ... +70 °C
Housing material	Plastic, black, UL 94 V0

Identification

Part number

Drawing

Dimensions in mm

Connector set, plastic

incl. housing and male insert

Han® RJ Industrial
Category 5, 4-poles, IDC contacts

6.5 - 9.5 mm clamp range

5 - 8 mm clamp range

09 35 221 0421

09 35 222 0421

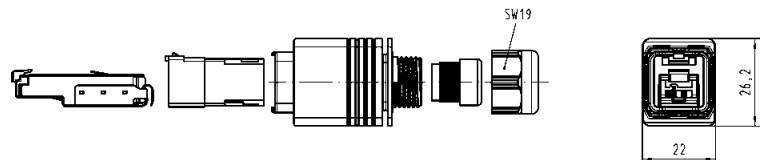

Han® RJ Industrial PN
Category 5, 4-poles, IDC contacts

6.5 - 9.5 mm clamp range

PROFINET-Identification:
PROFINET O-Plug RJ45

09 35 226 0421

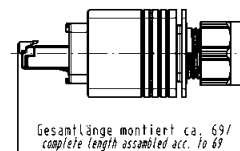

Han® RJ Industrial 10G
Category 6, 8-poles, IDC contacts

6.5 - 9.5 mm clamp range

5 - 8 mm clamp range

09 35 225 0421

09 35 228 0421



Han® PushPull, type acc. to IEC 61 076-3-117 variant 14 RJ45 connector

Features

- HARTING PushPull technology
- Field-assembly connector with piercing contacts
- Fully shielded

Technical characteristics

Locking	PushPull technology acc. to IEC 61 076-3-117
Degree of protection	IP65 / IP67
Mating face	RJ45 acc. to IEC 60 603-7
Shielding	Fully shielded, 360° shielding contact
Number of contacts	8
Transmission performance	acc. to ISO/IEC 11 801:2002, EN 50 173-1, category 6 _A / class E _A up to 500 MHz
Transmission rate	10/100 Mbit/s and 1/10 Gbit/s
Termination	with piercing contacts
Conductor cross section	AWG 24/7 - 27/7 (stranded)
Cable diameter	1.05 mm
Mating cycles	min. 750
Temperature range	-40 °C ... +70 °C
Housing material	Plastic, black, UL 94 V0

Identification

Part number

Drawing

Dimensions in mm

Connector set, plastic
incl. housing and male insert
5 - 8 mm clamp range

Han® RJ Industrial
Category 6_A, 8-poles,
piercing contacts

suitable assembly tool

09 35 227 0421

09 45 800 0520

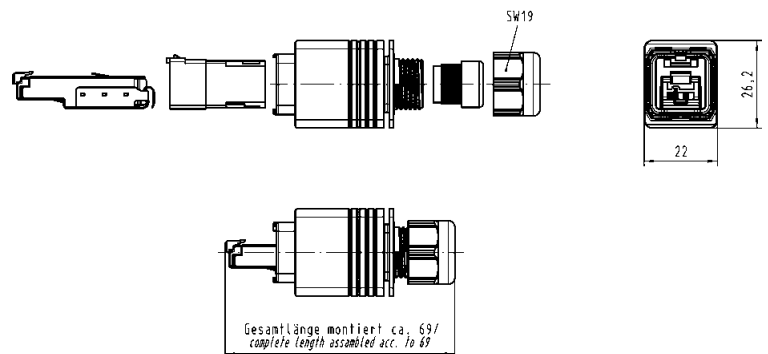



Han® PushPull, type acc. to IEC 61 076-3-117 variant 14
Housing bulkhead mounting for device integration and RJ45 jacks

Features

- HARTING PushPull technology
- Compact design
- High packing density
- Device integration via RJ45 PCB connectors

Technical characteristics

Locking	PushPull technology acc. to IEC 61 076-3-117
Degree of protection	IP65 / IP67
Mating face	RJ45 acc. to IEC 60 603-7
Termination type	Jack with solder termination
Mating cycles	min. 750
Temperature range	-40 °C ... +70 °C
Housing material	Zinc die-cast, nickel plated

Identification

Part number

Drawing

Dimensions in mm

Components device side

Housing bulkhead mounting metal

09 35 002 0301

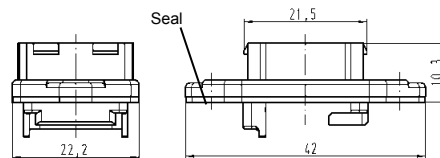

Protection cover IP65 / IP67

09 35 002 5402

Panel cut out

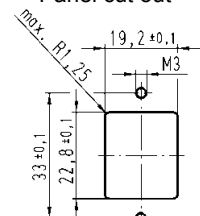

RJ45 jack

Solder variant, 90° angled

09 35 002 2101¹⁾

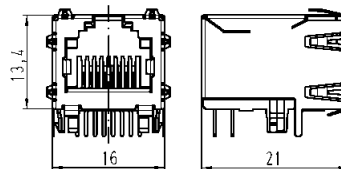

Solder variant, 180° straight

09 35 002 2102²⁾

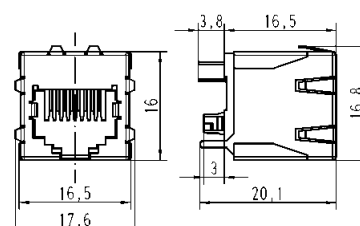

PCB layout

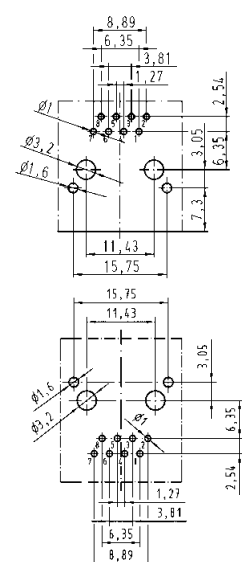

1) Packaging: Blister à 90 pieces
2) Packaging: Blister à 100 pieces



Han® PushPull, type acc. to IEC 61 076-3-117 variant 14
RJ45 10G panel feed through

Features

- HARTING PushPull technology
- Compact and robust design
- 360° shielding
- RJ45 mating compatible
- Transmission category 6, performance class E_A, suitable for 1/10 Gigabit Ethernet
- PROFINET conform

Technical characteristics

Locking	PushPull technology acc. to IEC 61 076-3-117 variant 14 RJ45 acc. to IEC 60 603-7
Mating face	
Transmission performance	Category 6 / class E _A acc. to ISO/IEC 11 801:2002, EN 50 173-1
Transmission rate	10/100 Mbit/s and 1/10 Gbit/s
Shielding	Fully shielded, 360° shielding contact
Mounting	Screwable to cover plates
Degree of protection	IP65 / IP67
Mating cycles	min. 750
Temperature range	-40 °C ... +70 °C
Housing material	Zinc die-cast, nickel-plated

Identification

Part number

Drawing

Dimensions in mm

Han® PushPull RJ45 10G

Panel feed through, Cat. 6 including bulkhead housing for rectangular panel cut out, flat seal and HARTING RJ Industrial® 10G RJ45 bulkhead, isolated bulkhead fixture

09 35 225 0311

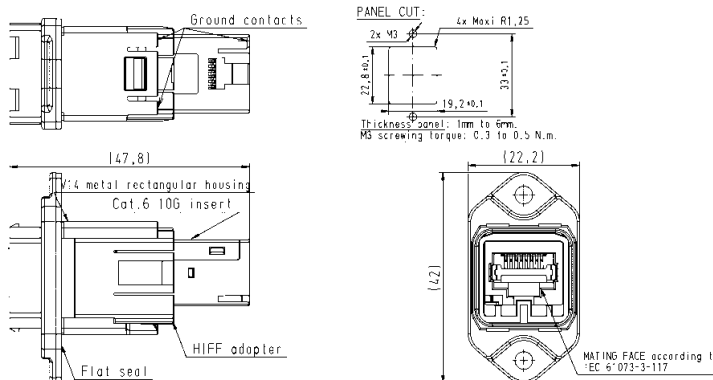

Panel feed through, Cat. 6 including bulkhead housing for circular panel cut out, flat seal and HARTING RJ Industrial® 10G RJ45 bulkhead, isolated bulkhead fixture

09 35 225 0312

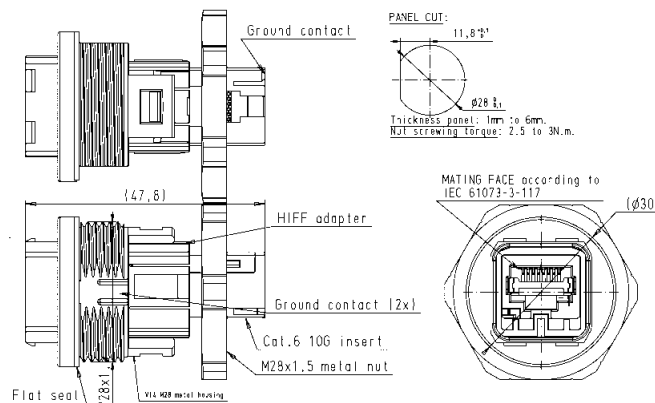

Identification

Part number

Drawing

Dimensions in mm

Han® PushPull RJ45 10G

Panel feed-through to mount HIFF inserts, e.g. Ha-VIS preLink® RJ45-module, RJ Industrial cable jack
Order inserts separately

Bulkhead housing for rectangular panel cut out, incl. plastic adapter

09 35 012 0311

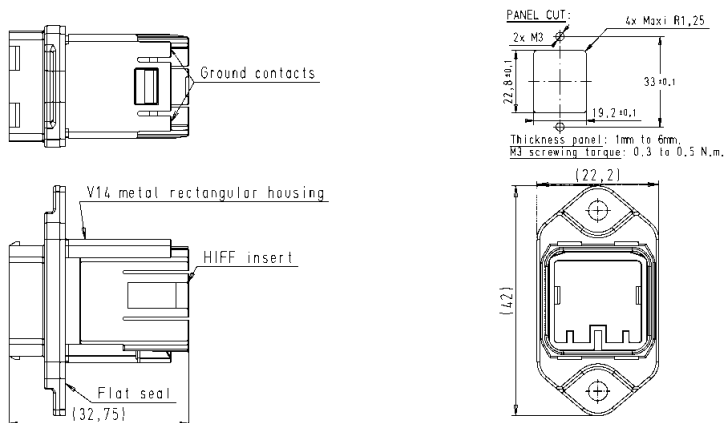

Bulkhead housing for circular panel cut out, incl. plastic adapter and fixing nut

09 35 012 0312

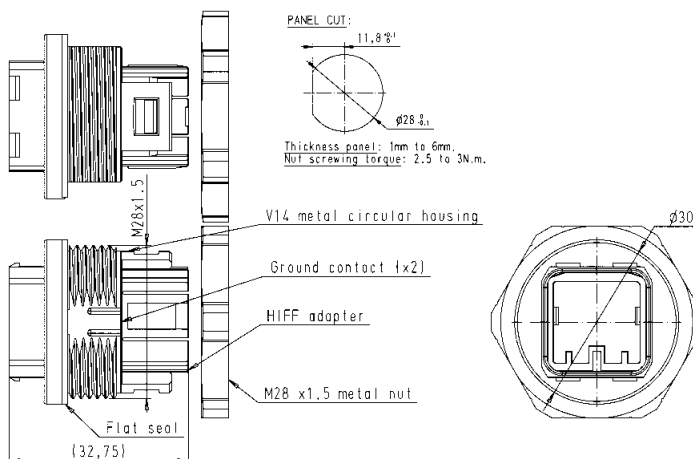

Ha-VIS preLink® set RJ45 jack AWG 22/23

consists of:

- 1x Ha-VIS preLink® module RJ45 jack
- 1x Ha-VIS preLink® terminal module
- 1x cable tie

20 82 001 0001

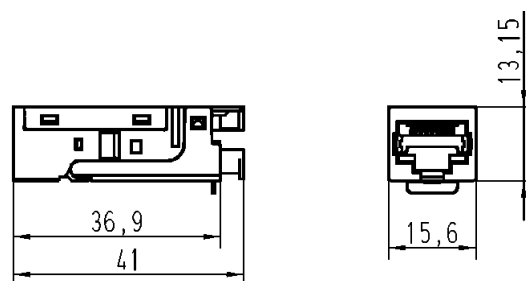

HARTING RJ Industrial® cable jack IDC

- AWG 22-24, 8-poles, Cat. 6
- AWG 24-28, 8-poles, Cat. 6
- AWG 22-24, 4-poles, Cat. 5

09 45 545 1562
09 45 545 1561
09 45 545 1120



Han® PushPull RJ45 Genderchanger Metal
Cat. 6 / Class E_A

Features

- High degree of protection IP65 / IP67
- Robust metal housing
- Standard PROFINET component of the German automotive production
- Allows usage of different cable types (Type B, C) e.g. in robots application
- Extension of cords according to PROFINET guideline
- Can be count as one connection acc. to IEC 11 801 Chapter 10.2.4

Technical characteristics

Transmission performance	Cat. 6 / Class E _A up to 500 MHz
Connector	Han® PushPull RJ45 (PROFINET conform)
Locking	PushPull technology acc. to IEC 61076-3-117 variant 14
Mating face	RJ45 acc. to IEC 60603-7
Mating cycles	min. 750
Housing material	Aluminium anodized
Dimensions	61.2 x 62 x 25.2 mm (unmated)
Degree of protection acc. to DIN 60529	IP65 / IP67 (mated)
Mounting	Wall mountable with 4 screws (type M5)
Temperature range	-40 °C ... +70 °C
Maximum permissible humidity	30 % ... 95 % (no condensation)

Identification	Part number	Drawing	Dimensions in mm
----------------	-------------	---------	------------------

Han® PushPull RJ45
Genderchanger metal

09 35 221 0501

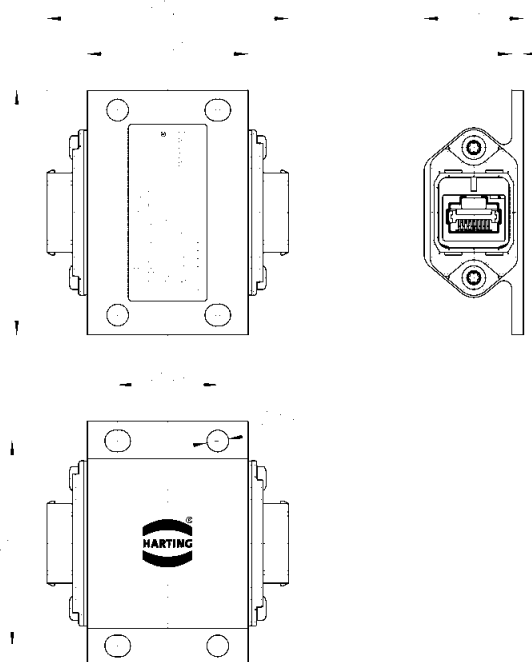



Han® PushPull RJ45 Coupling Metal Cat. 6 / Class E_A

Features

- High degree of protection IP65 / IP67
- Robust metal housing
- Standard PROFINET component of the German automotive production
- Extension of cords according to PROFINET guideline
- Can be count as one connection acc. to IEC 11 801 Chapter 10.2.4
- For an easy robot termination and a fast exchange of tube packages

Technical characteristics

Transmission performance	Cat. 6 / Class E _A up to 500 MHz
Transmission rate	10/100 Mbit/s and 1/10 Gbit/s
Locking	PushPull technology acc. to IEC 61076-3-117 variant 14
Mating face	RJ45 acc. to IEC 60603-7
Number of contacts	8
Usable cables	
Termination cross section	AWG 22-24 stranded/solid
Cable diameter	5 ... 9 mm
Conductor diameter	1.3 ... 1.6 mm
Mating cycles	min. 750
Housing material	Aluminium die-cast
Degree of protection acc. to DIN 60 529	IP65 / IP67
Temperature range	-40 °C ... +70 °C

Identification

Part number

Drawing

Dimensions in mm

Han® PushPull RJ45
Coupling metal
including housing,
Ha-VIS preLink® RJ45 jack,
bulkhead housing and cable gland

61 04 201 1084

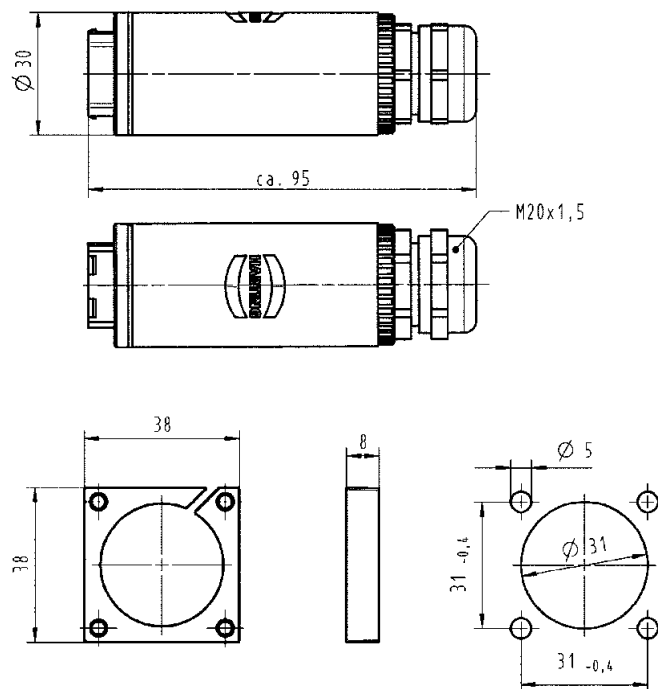

Fixing flange

61 04 600 0182



Han® PushPull, type acc. to IEC 61 076-3-117 variant 14 RJ45 connector

Features

- HARTING PushPull technology
- Field-assembly connector with IDC contacts
- Fully shielded

Technical characteristics

Locking	PushPull technology acc. to IEC 61 076-3-117
Degree of protection	IP65 / IP67
Mating face	RJ45 acc. to IEC 60 603-7
Shielding	Fully shielded, 360° shielding contact
Number of contacts	4 respectively 8
Transmission performance	acc. to ISO/IEC 11 801:2002, EN 50 173-1, category 5 / class D up to 100 MHz category 6 / class E _A up to 500 MHz
Transmission rate	10/100 Mbit/s and 1/10 Gbit/s
Termination	with IDC contacts, no tools needed / field-assembly
for Cat. 5	
Conductor cross section	AWG 24/7 - 22/7 (stranded) AWG 23/1 - 22/1 (solid)
Cable diameter	1.6 mm
for Cat. 6	
Conductor cross section	AWG 22/7 - 27/7 (stranded) AWG 22/1 - 27/1 (solid)
Cable diameter	1.6 mm
Mating cycles	min. 750
Temperature range	-40 °C ... +70 °C
Housing material	Zinc die-cast, nickel-plated

Identification	Part number	Drawing	Dimensions in mm
----------------	-------------	---------	------------------

Connector set, metal
incl. housing and male insert
4 - 11 mm clamp range

Han® RJ Industrial
Category 5, 4-poles, IDC contacts

09 35 221 0401

Han® RJ Industrial PN
Category 5, 4-poles, IDC contacts
PROFINET-Identification:
PROFINET O-Plug RJ45

09 35 226 0401

Han® RJ Industrial 10G
Category 6, 8-poles, IDC contacts

09 35 225 0401

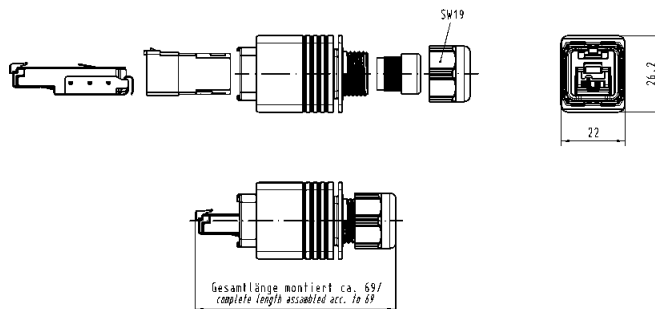



Han® PushPull, type acc. to IEC 61 076-3-117 variant 14
RJ45 connector angled

Features

- HARTING PushPull technology
- Angled cable exit 45° to the top / bottom for a space saving cabling
- Field-assembly connector with IDC contacts
- Fully shielded

Technical characteristics

Locking	PushPull technology acc. to IEC 61 076-3-117
Degree of protection	IP65 / IP67
Mating face	RJ45 acc. to IEC 60 603-7
Shielding	Fully shielded, 360° shielding contact
Number of contacts	4 respectively 8
Transmission performance	acc. to ISO/IEC 11 801:2002, EN 50 173-1, category 5 / class D up to 100 MHz category 6 / class E _A up to 500 MHz
Transmission rate	10/100 Mbit/s and 1/10 Gbit/s
Termination	with IDC contacts, no tools needed / field-assembly
for Cat. 5	
Conductor cross section	AWG 24/7 - 22/7 (stranded) AWG 23/1 - 22/1 (solid)
Cable diameter	1.6 mm
for Cat. 6	
Conductor cross section	AWG 22/7 - 27/7 (stranded) AWG 22/1 - 27/1 (solid)
Cable diameter	1.6 mm
Mating cycles	min. 750
Temperature range	-40 °C ... +70 °C
Housing material	Zinc die-cast, nickel-plated

Identification	Part number	Drawing	Dimensions in mm
----------------	-------------	---------	------------------

Connector set,
metal

incl. housing
and male insert

Han® RJ Industrial PN
Category 5, 4-poles, IDC contacts,
6.5 - 9.5 mm clamp range

Cable exit bottom side

09 35 226 0402

Cable exit top side

09 35 226 0403

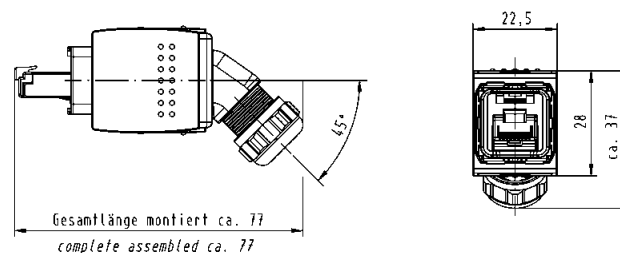

Han® RJ Industrial 10G
Category 6, 8-poles, IDC contacts,
6.5 - 9.5 mm clamp range

Cable exit bottom side

09 35 225 0402

Cable exit top side

09 35 225 0403

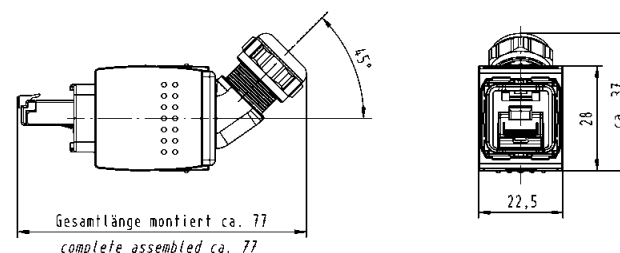



Han® PushPull, type acc. to IEC 61 076-3-117 variant 14 RJ45 connector

Features

- HARTING PushPull technology
- Compact design
- For space saving fitting conditions
- Connector with piercing contacts
- 360° shielding

Technical characteristics

Locking	PushPull technology acc. to IEC 61 076-3-117
Degree of protection	IP65 / IP67
Mating face	RJ45 acc. to IEC 60 603-7
Shielding	Fully shielded, 360° shielding contact
Number of contacts	8
Transmission performance	acc. to ISO/IEC 11 801:2002, EN 50 173-1, category 6 _A / class E _A up to 500 MHz
Transmission rate	10/100 Mbit/s and 1/10 Gbit/s
Termination	with piercing contacts
Conductor cross section	AWG 24/7 - 27/7 (stranded)
Cable diameter	1.05 mm
Mating cycles	min. 750
Temperature range	-40 °C ... +70 °C
Housing material	Zinc die-cast, nickel-plated

Identification	Part number	Drawing	Dimensions in mm
----------------	-------------	---------	------------------

Connector set, metal
incl. housing and male insert
4 - 11 mm clamp range

Han® RJ Industrial
Category 6, 8-poles,
piercing contacts

09 35 227 0401

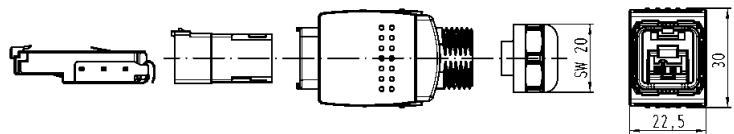

suitable assembly tool

09 45 800 0520



Han® PushPull, type acc. to IEC 61076-3-117 variant 14 preLink® RJ45-connector, straight and angled

Advantages

- HARTING PushPull technology
- 45° angled cable entry, bottom side, for space saving cabling
- 360° shielding
- Category of transmission Cat. 6A
- Suitable for solid and stranded wires
- Suitable for PoE (IEEE 802.3af) and PoE+ (IEEE 802.3at)

Technical characteristics

Locking	PushPull technology acc. to IEC 61076-3-117
Degree of protection	IP65 / IP67
Mating face	RJ45 acc. to IEC 60603-7
Number of contacts	8
Transmission category	Category 6A, Class E _A , suitable for 1/10 Gigabit Ethernet
Transmission performance	Category 6A / Class E _A up to 500 MHz acc. to ISO/IEC 11801:2002, EN 50173-1
Transmission rate	10/100 Mbit/s and 1/10 Gbit/s
Shielding	fully shielded, 360° shielding contact
Mounting	IDC termination
Cable termination for preLink® Connectable cables	terminal module, yellow, 20 82 000 0001
– Conductor cross section	AWG 23 ... AWG 22 (solid and stranded)
– Conductor diameter	1.3 ... 1.6 mm
Cable termination for preLink® Connectable cables	terminal module, white, 20 82 000 0003
– Conductor cross section	AWG 27 ... AWG 26 (solid and stranded)
– Conductor diameter	0.8 ... 1.1 mm
Cable diameter	6.3 ... 8.8 mm
Mating cycles	min. 750
Temperature range	-40 °C ... +70 °C
Housing material	Zinc die-cast, nickel-plated

Identification

Part number

Drawing

Dimensions in mm

Han® PushPull preLink® RJ45 connector, straight

20 82 104 0001

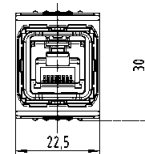
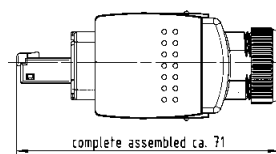

Han® PushPull preLink® RJ45 connector, angled

20 82 104 0045

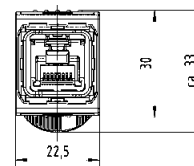
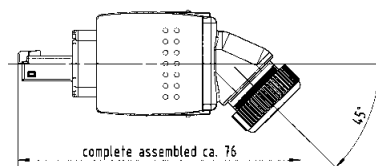

Ha-VIS preLink® RJ45 terminal module

AWG 22/23, yellow¹⁾
AWG 26/27, white¹⁾

20 82 000 0001
20 82 000 0003

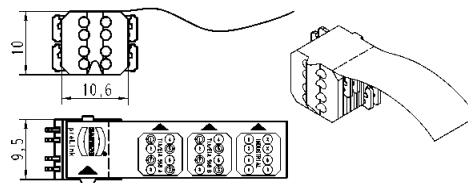

Ha-VIS preLink® assembly tool

20 82 000 9901

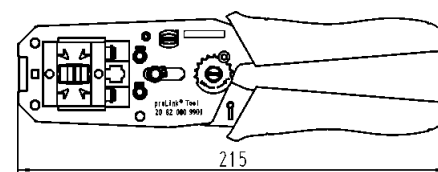

¹⁾ Packaging with 10 pieces



Han® PushPull, type acc. to IEC 61076-3-117 variant 14 cable to cable housing

Features

- HARTING PushPull technology
- Ideal for prototyping
- Can be combined with panel feed-throughs for power, data and signal

Technical characteristics

Locking	PushPull technology acc. to IEC 61076-3-117 variant 14
Degree of protection	IP65 / IP67
Outer cable diameter	6.5 ... 9.5 mm / 9 ... 13 mm
Mating cycles	min. 750
Temperature range	-40 °C ... +70 °C
Housing material	Plastic, black
Flammability acc. to UL 94	V0

Identification	Part number	Drawing	Dimensions in mm
----------------	-------------	---------	------------------

Han® PushPull cable to cable housings, plastic
(Order housing bulkhead mounting and insert separately)

for outer cable diameter 6.5 ... 9.5 mm

09 35 002 0431

2X REMFORM $\phi 3 \times 8$ TORX screws

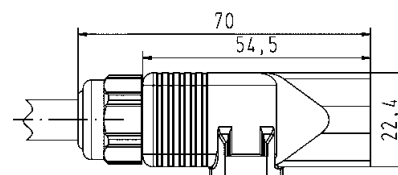
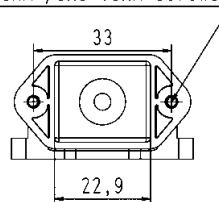

for outer cable diameter 9 ... 13 mm

09 35 002 0433

2X REMFORM $\phi 3 \times 8$ TORX screws

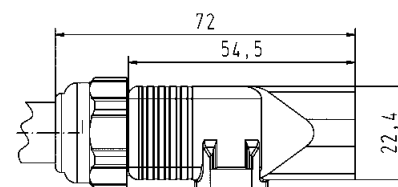
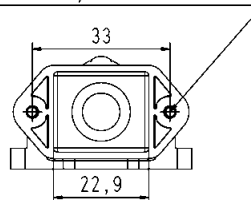

Suitable bulkhead housing, plastic

for RJ45

09 35 012 0331

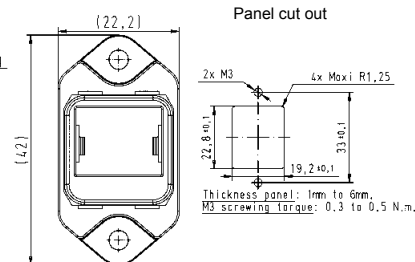
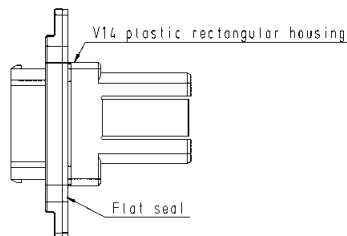

Inserts for RJ45

- RJ 45: 8-poles, Cat. 6 / class E_A
 Ha-Vis preLink® set AWG 22/23
 HARTING RJ Industrial® cable jack with IDC termination
- AWG 22-24, 8-poles
 - AWG 24-28, 8-poles
 - AWG 22-24, 4-poles, Cat. 5



20 82 001 0001

09 45 545 1562

09 45 545 1561

09 45 545 1120

Han® PushPull, type acc. to IEC 61 076-3-117 variant 14 Accessories

Identification	Part number	Drawing	Dimensions in mm
<p>Han® PushPull protection cover IP65 / IP67 for device side</p> <p>without fixing cord</p> <p>with fixing cord</p> <p>with nylon fixing cord</p>	<p>09 35 002 5403 XL¹⁾</p> <p>09 35 002 5402 09 35 002 5402 XL¹⁾</p> <p>09 35 002 5404 09 35 002 5404 XL²⁾</p>		
<p>Han® PushPull protection cover IP65 / IP67 for cable side</p> <p>without fixing cord</p> <p>with nylon fixing cord</p>	<p>09 35 002 5411</p> <p>09 35 002 5413</p>		

¹⁾ Packaging with 100 pieces

²⁾ Packaging with 250 pieces



Han® PushPull, type acc. to IEC 61076-3-117 variant 14
 Housing bulkhead mounting for device integration
 Optical connector based on SCRJ

Features

- HARTING PushPull technology
- Compact design
- High packing density
- Device integration via transceiver
- Han® PushPull SCRJ for POF is according the requirements of AIDA (German Domestic Automobile Manufacturers)

Technical characteristics

Locking	PushPull technology
Degree of protection	IP65 / IP67
Mating face	SCRJ acc. to IEC 61754-24
Fiber Typen	POF ¹⁾ 1 mm HCS ²⁾ 200 µm / 230 µm MM 62.5 µm / 125 µm MM 50 µm / 125 µm SM 10 µm / 125 µm
Mating cycles	min. 750
Temperature range	-40 °C ... +70 °C
Housing material	Plastic, black
Flammability acc. to UL 94	V0

Identification

Part number

Drawing

Dimensions in mm

Components device side

Housing bulkhead mounting
 Optical transceiver
 not included

plastic

09 35 002 0323

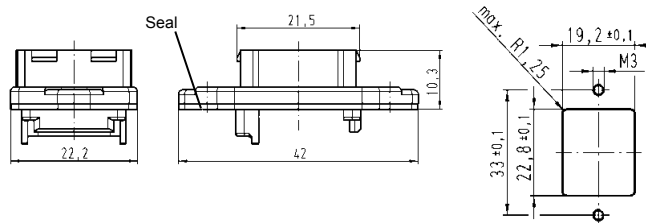

Protection cover IP65 / IP67

09 35 002 5402

Reference for transceiver
 as well as mounting instruction
 on request

1) POF = Polymer-Optical Fibre

2) HCS® = Hard Clad Silica (registered trademark of SpecTran Corporation)



PushPull

Han® PushPull, type acc. to IEC 61 076-3-117 variant 14
RJ45 panel feed through
for optical connector based on SCRJ

Features

- HARTING PushPull technology
- Compact design
- High packing density
- Han® PushPull SCRJ for POF is according the requirements of AIDA (German Domestic Automobile Manufacturers)

Technical characteristics

Locking	PushPull technology
Degree of protection	IP65 / IP67
Mating face	SCRJ acc. to IEC 61 754-24
Fiber Typen	POF ¹⁾ 1 mm HCS ²⁾ 200 µm / 230 µm MM 62.5 µm / 125 µm MM 50 µm / 125 µm SM 10 µm / 125 µm
Mating cycles	min. 750
Temperature range	-40 °C ... +70 °C
Housing material	Plastic, black
Flammability acc. to UL 94	V0

Identification

Part number

Drawing

Dimensions in mm

Han® PushPull SCRJ

Panel feed through

09 35 242 0333

SC contacts order separately

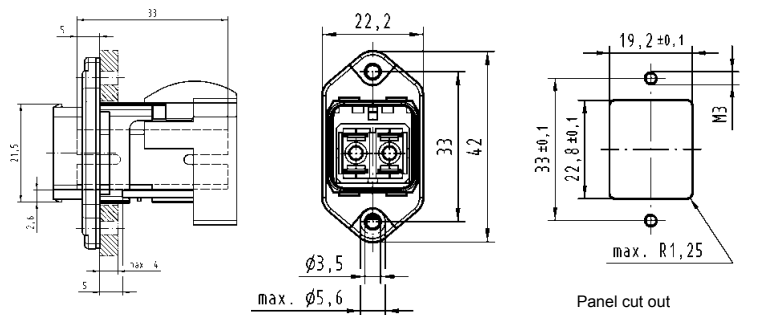

SCRJ IP20

POF connector

with fast termination

09 35 002 4002

with crimp termination

09 35 002 4003

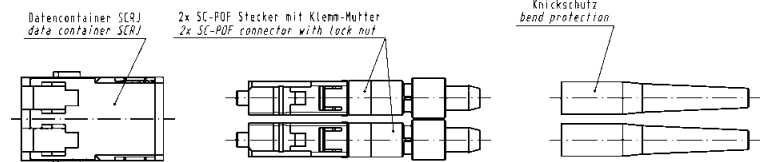

Contacts

SC POF contact, 1 mm

20 10 001 5217

SC 125 GI contact

20 10 125 5211

SC 230 HCS contact

20 10 230 5211

¹⁾ POF = Polymer-Optical Fibre

²⁾ HCS® = Hard Clad Silica (registered trademark of SpecTran Corporation)



PushPull



Han® PushPull, type acc. to IEC 61 076-3-117 variant 14 SCRJ connector

Features

- HARTING PushPull technology
- Compact design
- High packing density
- Han® PushPull SCRJ for POF is according the requirements of AIDA (German Domestic Automobile Manufacturers)
- Field installable

Technical characteristics

Locking	PushPull technology
Degree of protection	IP65 / IP67
Mating face	SCRJ acc. to IEC 61 754-24
Fiber Typen	POF ¹⁾ 1 mm HCS ²⁾ 200 µm / 230 µm MM 62.5 µm / 125 µm MM 50 µm / 125 µm SM 10 µm / 125 µm
Mating cycles	min. 750
Temperature range	-40 °C ... +70 °C
Housing material	Plastic, black
Flammability acc. to UL 94	V0
Cable diameter	6.5 - 9.5 mm

Identification	Part number	Drawing	Dimensions in mm
Connector set, plastic incl. housing and SCRJ insert, POF contacts PROFINET-Identification: PROFINET O-Plug SCRJ incl. housing and SCRJ insert SC contacts order separately	09 35 241 0421 09 35 241 0422		
SCRJ IP20 POF connector	09 35 002 4002		
Protection cover IP65 / IP67	09 35 002 5411		
Contacts SC POF contact, 1 mm SC 125 GI contact SC 230 HCS contact	20 10 001 5217 20 10 125 5211 20 10 230 5211		



Han® PushPull, type acc. to IEC 61076-3-117 variant 14
 Housing bulkhead mounting for device integration
 Optical connector based on SCRJ

Features

- HARTING PushPull technology
- Compact design
- High packing density
- Device integration via transceiver
- Han® PushPull SCRJ for POF is according the requirements of AIDA (German Domestic Automobile Manufacturers)

Technical characteristics

Locking	PushPull technology
Degree of protection	IP65 / IP67
Mating face	SCRJ acc. to IEC 61754-24
Fiber Typen	POF ¹⁾ 1 mm HCS ²⁾ 200 μm / 230 μm MM 62.5 μm / 125 μm MM 50 μm / 125 μm SM 10 μm / 125 μm
Mating cycles	min. 750
Temperature range	-40 °C ... +70 °C
Housing material	Zinc die-cast, nickel plated

Identification	Part number	Drawing	Dimensions in mm
----------------	-------------	---------	------------------

Components device side

Housing bulkhead mounting
 Optical transceiver
 not included

metal

09 35 002 0303

Protection cover IP65 / IP67

09 35 002 5402

Reference for transceiver
 as well as mounting instruction
 on request

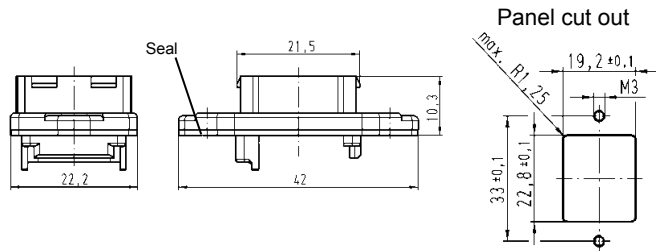

1) POF = Polymer-Optical Fibre
 2) HCS® = Hard Clad Silica (registered trademark of SpecTran Corporation)



Han® PushPull, type acc. to IEC 61 076-3-117 variant 14
RJ45 panel feed through
for optical connector based on SCRJ

Features

- HARTING PushPull technology
- Compact design
- High packing density
- Han® PushPull SCRJ for POF is according the requirements of AIDA (German Domestic Automobile Manufacturers)

Technical characteristics

Locking	PushPull technology
Degree of protection	IP65 / IP67
Mating face	SCRJ acc. to IEC 61 754-24
Fiber Typen	POF ¹⁾ 1 mm HCS ²⁾ 200 µm / 230 µm MM 62.5 µm / 125 µm MM 50 µm / 125 µm SM 10 µm / 125 µm
Mating cycles	min. 750
Temperature range	-40 °C ... +70 °C
Housing material	Zinc die-cast, nickel plated

Identification	Part number	Drawing	Dimensions in mm
Han® PushPull SCRJ Panel feed through SC contacts order separately	09 35 242 0313		Panel cut out
SCRJ IP20 POF connector with fast termination with crimp termination	09 35 002 4002 09 35 002 4003		
Contacts SC POF contact, 1 mm SC 125 GI contact SC 230 HCS contact	20 10 001 5217 20 10 125 5211 20 10 230 5211		

1) POF = Polymer-Optical Fibre
2) HCS® = Hard Clad Silica (registered trademark of SpecTran Corporation)



PushPull

Han® PushPull, type acc. to IEC 61 076-3-117 variant 14
SCRJ connector with fast termination

Features

- HARTING PushPull technology
- Compact design
- High packing density
- Han® PushPull SCRJ for POF is according the requirements of AIDA (German Domestic Automobile Manufacturers)
- Field installable

Technical characteristics

Locking	PushPull technology
Degree of protection	IP65 / IP67
Mating face	SCRJ acc. to IEC 61 754-24
Fiber Typen	POF ¹⁾ 1 mm HCS ²⁾ 200 µm / 230 µm MM 62.5 µm / 125 µm MM 50 µm / 125 µm SM 10 µm / 125 µm
Mating cycles	min. 750
Temperature range	-40 °C ... +70 °C
Housing material	Zinc die-cast, nickel plated
Flammability acc. to UL 94	V0
Cable diameter	6.5 - 9.5 mm

Identification	Part number	Drawing	Dimensions in mm
----------------	-------------	---------	------------------

Connector set, metal
incl. housing and SCRJ insert,
POF contacts

09 35 241 0401

PROFINET-Identification:
PROFINET O-Plug SCRJ

incl. housing and SCRJ insert
SC contacts order separately

09 35 241 0402

**SCRJ IP20
POF connector**

09 35 002 4002

Protection cover IP65 / IP67

09 35 002 5411

Contacts

- SC POF contact, 1 mm
- SC 125 GI contact
- SC 230 HCS contact

20 10 001 5217
20 10 125 5211
20 10 230 5211

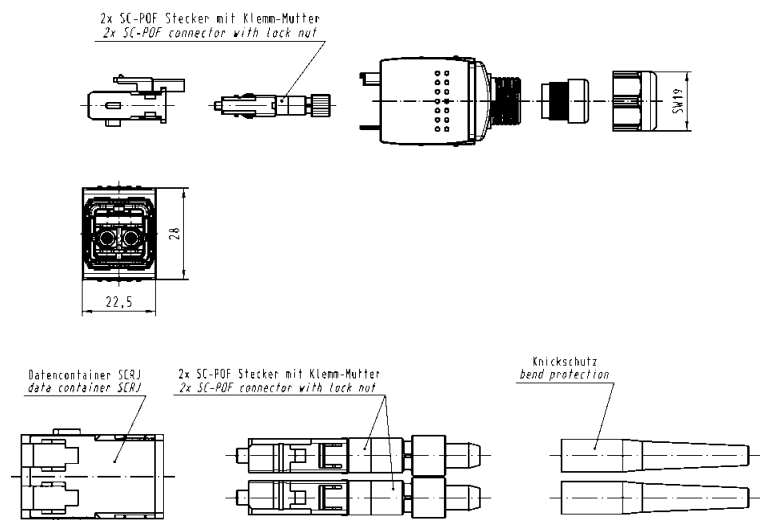

Tooling see page 02.57

¹⁾ POF = Polymer-Optical Fibre

²⁾ HCS® = Hard Clad Silica (registered trademark of SpecTran Corporation)



PushPull



Han® PushPull, type acc. to IEC 61 076-3-117 variant 14
SCRJ crimp connector

Features

- HARTING PushPull technology
- Compact design
- High packing density
- Han® PushPull SCRJ for POF is according the requirements of AIDA (German Domestic Automobile Manufacturers)

Technical characteristics

Locking	PushPull technology
Degree of protection	IP65 / IP67
Mating face	SCRJ acc. to IEC 61 754-24
Fiber Typen	POF ¹⁾ 980 µm / 1000 µm
Mating cycles	min. 750
Temperature range	-40 °C ... +70 °C
Housing material	Zinc die-cast, nickel plated
Flammability acc. to UL 94	V0
Cable diameter	6.5 - 9.5 mm

Identification

Part number

Drawing

Dimensions in mm

Connector set, metal

incl. housing and SCRJ insert,
POF crimp contacts

09 35 242 0401

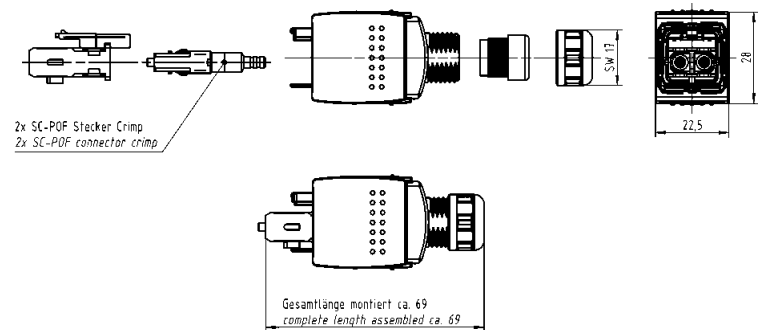

SCRJ IP20

POF crimp connector

09 35 002 4003

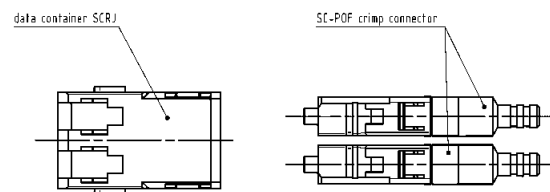

Protection cover

IP65 / IP67

09 35 002 5411

Contacts

SC POF crimp contact

20 10 001 5211



PushPull

Han® PushPull SCRJ Genderchanger Metal

Features

- High degree of protection IP65 / IP67
- Robust metal housing
- Standard PROFINET component of the German automotive production
- Allows usage of different cable types (Type B, C) e.g. in robots application
- Extension of cords according to PROFINET guideline

Technical characteristics

Locking	PushPull technology
Degree of protection	IP65 / IP67 (mated)
Mating face	SCRJ acc. to IEC 61 754-24
Fibre types	POF, GOF, HCS
Number of contacts	2
Mating cycles	min. 750
Temperature range	-40 °C ... +70 °C
Housing material	Zinc die-cast, nickel-plated
Dimensions	43.3 x 42 x 29 mm (unmated)
Mounting	Wall mountable with 2 screws (type M3)

Identification

Part number

Drawing

Dimensions in mm

Han® PushPull SCRJ Genderchanger metal

09 35 241 0501

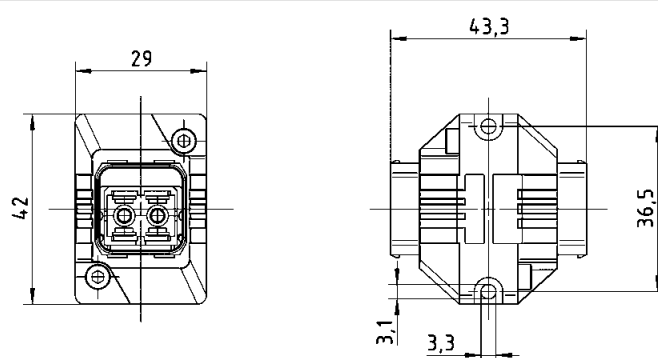



Han® PushPull SCRJ POF crimp
Assembly tools for polymer-optical fibres

Features

- Cable insulation (PUR / PVC) is stripped without damage
- The 'crimping' and 'precision cutting' operations are completed within the one tool
- Specialized cutting method with an automatically advancing round blade for an accurate cutting result requiring no final polishing
- Optical display indicating remaining operations
- Simultaneous crimping of two contacts (duplex handling)

Technical characteristics

Connector type	SCRJ crimp connector acc. to IEC 61754-24
Locking	PushPull technology acc. to IEC 61076-3-117 variant 14 (AIDA compliant)
Insertion loss	typically 1.5 to 2.0 dB
Termination SC contacts	Crimp termination technique
Fibre dimensions	POF 980 / 1000 µm
Fibre outer diameter	2.2 mm
Cable outer diameter	7 to 8.5 mm
No. of cutting operations	Maximum 1260

Identification	Part number	Drawing	Dimensions in mm
<p>Assembly tool set for POF crimp cutting, without final polishing</p> <p>The set contains</p> <ul style="list-style-type: none"> - one crimping and cutting tool for 1260 operations - one sheath stripping tool - one Kevlar shear - one loading device for SC contacts <p>Supplied in a robust plastic case</p>	09 35 000 9915		
Replacement cutting tool	09 35 000 9914		



Han® PushPull SCRJ POF Assembly tools for polymer-optical fibres

Features

- Cable insulation (PUR / PVC) is stripped without damage
- The 'stripping' and 'precision cutting' operations are completed within the one tool
- Specialized cutting method with an automatically advancing round blade for an accurate cutting result requiring no final polishing
- Optical display indicating remaining operations
- Simultaneous handling of twin fibers (duplex mode)

Technical characteristics

Connector type	SCRJ connector acc. to IEC 61 754-24
Locking	PushPull technology acc. to IEC 61 076-3-117 variant 14 (AIDA compliant)
Insertion loss	typically 1.5 to 2.0 dB
Termination SC contacts	Fast termination technique, reusable
Fibre dimensions	POF 980 / 1000 µm
Fibre outer diameter	2.2 mm
Cable outer diameter	7 to 8.5 mm
No. of cutting operations	Maximum 1260

Identification	Part number	Drawing	Dimensions in mm
Assembly tool set for POF cutting, without final polishing The set contains - one stripping and cutting tool for 1260 operations - one sheath stripping tool - one Kevlar shear - one positioner for SCRJ contacts Supplied in a robust plastic case	09 35 000 9913		
Replacement cutting tool for 1260 operations	09 35 000 9914		
Assembly tool set for POF cutting, with final polishing Without an optical meter With an optical meter	20 99 000 3016 20 99 000 3013		
Polishing wheel (grinding wheel) for POF cables 2.2	20 99 000 1099		
Sand paper for POF, grain size 1000	20 80 001 9911		



Han® PushPull, type acc. to IEC 61 076-3-117 variant 14
10-poles 50 V / 5 A

Features

- HARTING PushPull technology
- For the transmission of analog, low voltage and bus signals
- Fully shielded
- 10 contacts
- Touch-proof
- Easy and fast cable installation

Technical characteristics

Locking	PushPull technology acc. to IEC 61076-3-117 variant 14
Degree of protection	IP65 / IP67
Mating face	acc. to IEC/PAS 61076-3-119
Number of contacts	10
Electrical data acc. to DIN EN 61984	5 A 50 V 1.5 kV 3
Contact resistance	10 mΩ
Termination	Crimp
Conductor cross section	AWG 24 ... 18; 0.25 ... 0.82 mm ²
Conductor diameter	max. 2.1 mm
Outer cable diameter	6.5 ... 9.5 mm / 4 ... 11 mm
Shielding	Fully shielded, 360° shielding contact
Mating cycles	min. 500
Temperature range	-40 °C ... +70 °C
Housing material	Plastic, black Zinc die-cast, nickel-plated
Flammability acc. to UL 94	V0

Identification	Part number	Drawing	Dimensions in mm
----------------	-------------	---------	------------------

Han® PushPull Signal Insert

for panel feed-through HIFF,
10-poles
incl. male insert

Order D-Sub crimp male
contacts separately

D-Sub crimp contacts for device side³⁾

male, turned
AWG 24-20; 0.25-0.56 mm²

male, turned
AWG 22-18; 0.33-0.82 mm²

male, stamped
AWG 24-20; 0.25-0.56 mm²

09 45 545 9010

09 67 000 8576¹⁾

09 67 000 3576¹⁾

09 67 000 8178²⁾

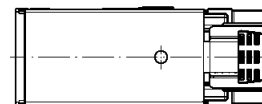
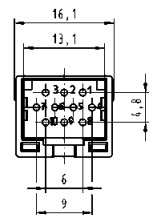
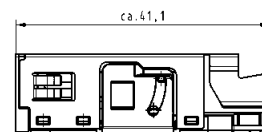
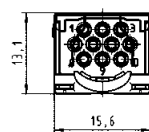

¹⁾ To be used with crimp tool 09 99 000 0501. Suitable locator: 09 99 000 0531

²⁾ To be used with crimp tool 09 99 000 0175.

³⁾ For all usable D-Sub contacts please see chapter 05.

Identification Part number Drawing Dimensions in mm

Han® PushPull panel feed-through HIFF
to hold the 10-poles insert

Metal rectangular

09 35 012 0311

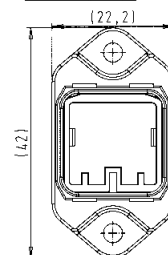
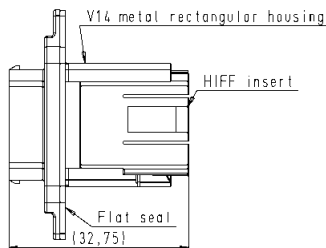
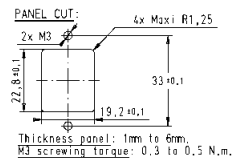
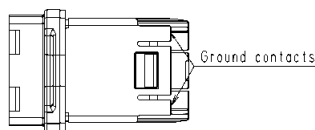

Metal circular

09 35 012 0312

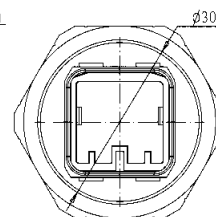
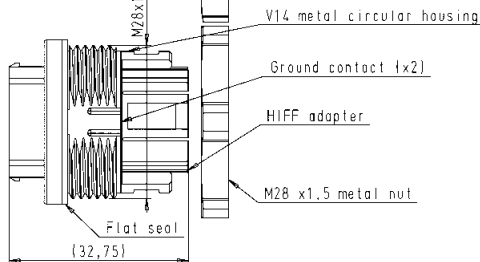
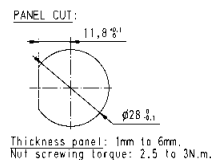
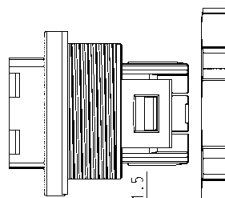

Plastic rectangular

09 35 012 0331

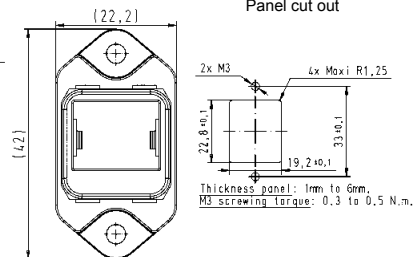
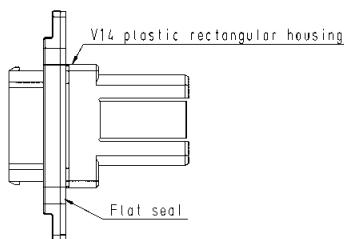

Han® PushPull Signal solder jack angled

09 35 002 6001

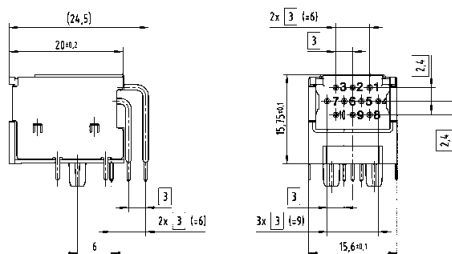

Han® PushPull Signal solder jack straight

09 35 002 6002

suitable housings,
bulkhead mounting

Metal

09 35 002 0303

Plastic

09 35 002 0323

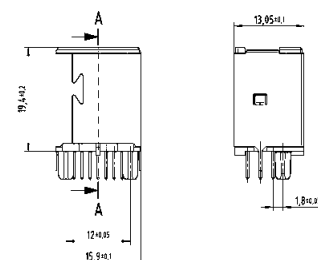



Han® PushPull, type acc. to IEC 61 076-3-117 variant 14
10-poles 50 V / 5 A

Features

- HARTING PushPull technology
- For the transmission of analog, low voltage and bus signals
- Fully shielded
- 10 contacts
- Touch-proof
- Easy and fast cable installation

Technical characteristics

Locking	PushPull technology acc. to IEC 61076-3-117 variant 14
Degree of protection	IP65 / IP67
Mating face	acc. to IEC/PAS 61076-3-119
Number of contacts	10
Electrical data acc. to DIN EN 61984	5 A 50 V 1.5 kV 3
Contact resistance	10 mΩ
Termination	Crimp
Conductor cross section	AWG 24 ... 18; 0.25 ... 0.82 mm ²
Conductor diameter	max. 2.1 mm
Outer cable diameter	6.5 ... 9.5 mm / 4 ... 11 mm
Shielding	Fully shielded, 360° shielding contact
Mating cycles	min. 500
Temperature range	-40 °C ... +70 °C
Housing material	Plastic, black Zinc die-cast, nickel-plated
Flammability acc. to UL 94	V0

Identification	Part number	Drawing	Dimensions in mm
----------------	-------------	---------	------------------

Han® PushPull Signal

Connector set 10-poles
incl. metal housing
and female insert

4 ... 7 / 7 ... 11 mm clamp range
7 ... 11 mm clamp range

09 35 261 0401
09 35 262 0401

Connector set 10-poles
incl. plastic housing
and female insert

6.5 ... 9.5 mm clamp range

09 35 261 0421

Order D-Sub crimp female
contacts separately

D-Sub crimp contacts for cable side³⁾

female, turned
AWG 24-20; 0.25 - 0.52 mm²

09 67 000 8476¹⁾

female, turned
AWG 22-18; 0.33 - 0.82 mm²

09 67 000 3476¹⁾

female, stamped
AWG 24-20; 0.25 - 0.56 mm²

09 67 000 8278²⁾

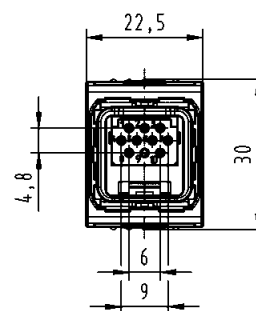
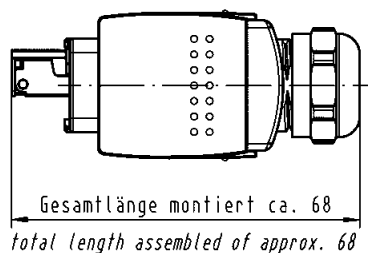

¹⁾ To be used with crimp tool 09 99 000 0501. Suitable locator: 09 99 000 0531

²⁾ To be used with crimp tool 09 99 000 0175.

³⁾ For all usable D-Sub contacts please see chapter 05.



Han® PushPull, type acc. to IEC 61 076-3-118
Housing bulkhead mounting and power females for device integration

Features

- HARTING PushPull technology
- Compact, space-saving design
- Touch-proof
- Device side: male
 - Solder variant, angled and straight
- 4 times coding without contact loss

Technical characteristics

Locking	PushPull technology acc. to IEC 61 076-3-118
Degree of protection	IP65 / IP67
Number of contacts	4 + PE
Electrical data acc. to DIN EN 61984	16 A 230/400 V 4 kV 3
Termination	Male insert with solder termination
Mating cycles	min. 500
Temperature range	-40 °C ... +70 °C
Housing material	Plastic, black
Flammability acc. to UL 94	V0

Identification

Part number

Drawing

Dimensions in mm

Components device side

Housing bulkhead mounting plastic	09 35 002 0323
Protection cover IP65 / IP67	09 35 002 5402
Coding pins	09 35 000 6190
Male insert with solder termination angled	09 35 002 3003
Male insert with solder termination straight	09 35 002 3004

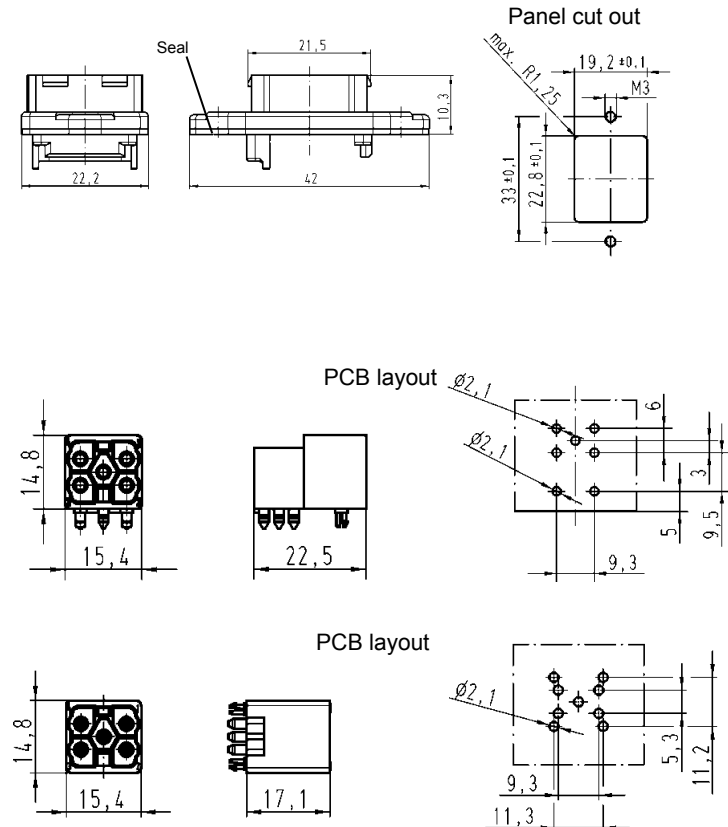

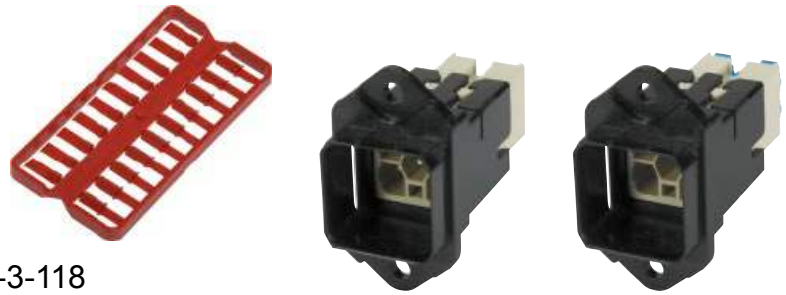

Han® PushPull, type acc. to IEC 61 076-3-118
Panel feed-through, 5-poles, 690 V, 16 A

Features

- HARTING PushPull technology
- Compact, space-saving design
- Touch-proof
- Panel feed-through: male
 - crimp termination
 - Han-Quick Lock® termination technology
- 4 times coding without contact loss
- NEW: Larger termination cross section for conductors 0.25 - 1.5 mm²

Technical characteristics

Locking	PushPull technology acc. to IEC 61 076-3-117 variant 14
Mating face	acc. to IEC 61 076-3-118
Degree of protection	IP65 / IP67
Number of contacts	4 + PE
Electrical data	16 A 690 V 4 kV 3
acc. to DIN EN 61 984	0.25 – 2.5 mm ²
Termination cross section	min. 500
Mating cycles	-40 °C ... +70 °C
Temperature range	Plastic, black
Housing material	V0
Flammability acc. to UL 94	

Identification	Part number	Drawing	Dimensions in mm
<p>Han® PushPull Power 4/0 Panel feed-through 5-poles, 690 V / 16 A incl. bulkhead housing and male insert</p> <p>with crimp termination (Order crimp male contacts separately)</p>	09 35 231 0331		
<p>with Han-Quick Lock® termination</p> <p>0.5 ... 2.5 mm² 0.25 ... 1.5 mm²</p>	09 35 232 0331 09 35 234 0331		
<p>Coding element 10 pieces each for device and cable side enables 4 times coding without contact loss</p>	09 35 000 6190		



Han® PushPull, type acc. to IEC 61 076-3-118
 Panel feed-through, 5-poles, 690 V, 16 A

Features

- HARTING PushPull technology
- Compact, space-saving design
- Touch-proof
- Panel feed-through: male
 - crimp termination
 - Han-Quick Lock® termination technology
- 4 times coding without contact loss
- NEW: Larger termination cross section for conductors 0.25 - 1.5 mm²

Technical characteristics

Locking	PushPull technology acc. to IEC 61 076-3-117 variant 14 acc. to IEC 61 076-3-118
Mating face	acc. to IEC 61 076-3-118
Degree of protection	IP65 / IP67
Number of contacts	4 + PE
Electrical data	
acc. to DIN EN 61 984	16 A 690 V 4 kV 3
Termination cross section	0.25 – 2.5 mm ²
Mating cycles	min. 500
Temperature range	-40 °C ... +70 °C
Housing material	Plastic, black
Flammability acc. to UL 94	V0

Identification	Part number	Drawing	Dimensions in mm
----------------	-------------	---------	------------------

**Han® PushPull Power 4/0
 Panel feed-through M25**

5-poles, 690 V / 16 A
 incl. bulkhead housing and male insert, circular panel cut out

with crimp termination
 (Order crimp male contacts separately)

with Han-Quick Lock® termination

0.5 ... 2.5 mm²
 0.25 ... 1.5 mm²

09 35 231 0332

09 35 232 0332
 09 35 234 0332

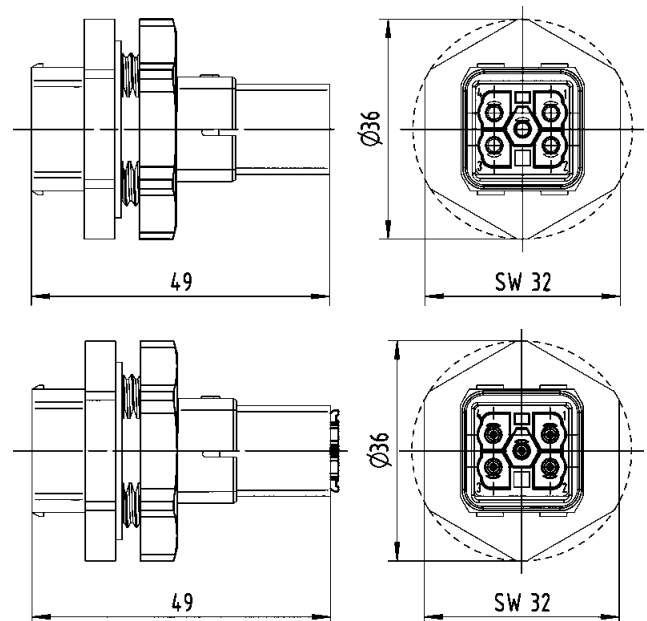

possible panel cut outs - thickness max. 3 mm

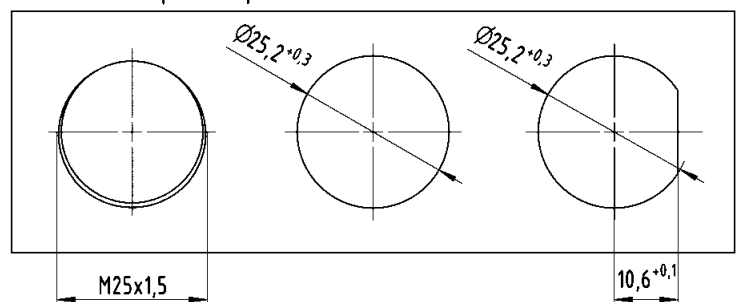

Coding element

10 pieces each for device and cable side
 enables 4 times coding without contact loss

09 35 000 6190

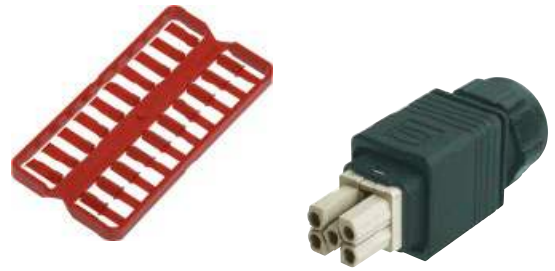

Han® PushPull, type acc. to IEC 61 076-3-118
Connector, 5-poles, 690 V, 16 A

Features

- HARTING PushPull technology
- Compact, space-saving design
- Touch-proof
- Cable side: female
 - crimp termination
 - Han-Quick Lock® termination technology
 Field-assembly without special tools
- 4 times coding without contact loss
- NEW: Larger termination cross section for conductors 0.25 - 1.5 mm²

Technical characteristics

Locking	PushPull technology acc. to IEC 61 076-3-117 variant 14
Mating face	acc. to IEC 61 076-3-118
Degree of protection	IP65 / IP67
Number of contacts	4 + PE
Electrical data	
acc. to DIN EN 61 984	16 A 690 V 4 kV 3
Termination cross section	0.25 – 2.5 mm ²
Mating cycles	min. 500
Temperature range	-40 °C ... +70 °C
Housing material	Plastic, black
Flammability acc. to UL 94	V0

Identification	Part number	Drawing	Dimensions in mm
----------------	-------------	---------	------------------

Connector set, plastic

incl. housing and female insert

with crimp termination
9 – 13 mm clamp range
Han® P crimp contacts
order separately

09 35 231 0423

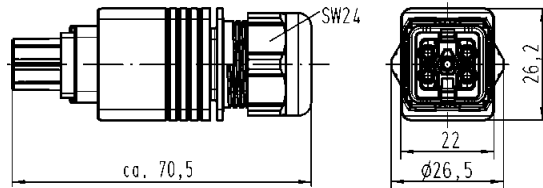

with Han-Quick Lock® termination
9 – 13 mm clamp range
for termination cross section 0.5 - 2.5 mm²

09 35 232 0423

with Han-Quick Lock® termination
6.5 – 9.5 mm clamp range
for termination cross section 0.5 - 2.5 mm²
for termination cross section 0.25 - 1.5 mm²

09 35 232 0421
09 35 234 0421

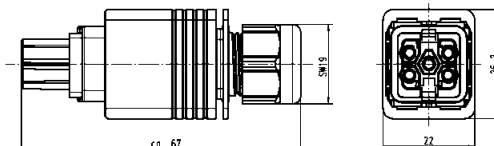

Protection cover IP65 / IP67

09 35 002 5411

Coding pins

09 35 000 6190



Han® PushPull, type acc. to IEC 61076-3-118
Housing bulkhead mounting and power females for device integration

Features

- HARTING PushPull technology
- Compact, space-saving design
- Touch-proof
- Device side: male
 - Solder variant, angled and straight
- 4 times coding without contact loss

Technical characteristics

Locking	PushPull technology acc. to IEC 61076-3-118
Degree of protection	IP65 / IP67
Number of contacts	4 + PE
Electrical data acc. to DIN EN 61984	16 A 690 V 4 kV 3
Termination	Male insert with solder termination
Mating cycles	min. 500
Temperature range	-40 °C ... +70 °C
Flammability acc. to UL 94	V0
Housing material	Zinc die-cast, nickel plated Plastic, black (female)

Identification

Part number

Drawing

Dimensions in mm

Components device side

Housing bulkhead mounting metal

09 35 002 0303

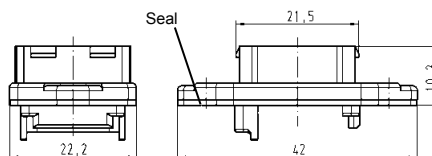

Panel cut out

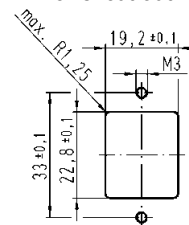

Protection cover IP65 / IP67

09 35 002 5402

Coding pins

09 35 000 6190

PCB layout

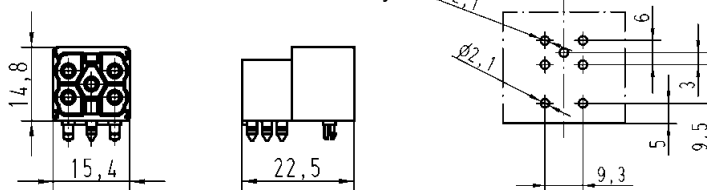

Male insert with solder termination angled

09 35 002 3003

PCB layout

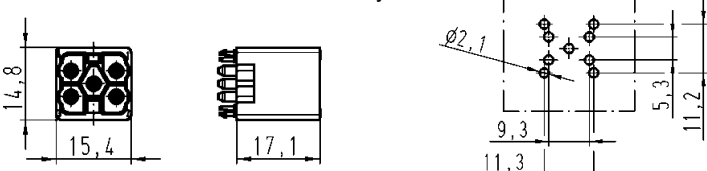

Male insert with solder termination straight

09 35 002 3004



Han® PushPull, type acc. to IEC 61 076-3-118
Panel feed-through, 5-poles, 690 V, 16 A

Features

- HARTING PushPull technology
- Compact, space-saving design
- Touch-proof
- Panel feed-through: male
 - crimp termination
 - Han-Quick Lock® termination technology
- 4 times coding without contact loss
- NEW: Larger termination cross section for conductors 0.25 - 1.5 mm²

Technical characteristics

Locking	PushPull technology acc. to IEC 61 076-3-117 variant 14
Mating face	acc. to IEC 61 076-3-118
Degree of protection	IP65 / IP67
Number of contacts	4 + PE
Electrical data	
acc. to DIN EN 61 984	16 A 690 V 4 kV 3
Termination cross section	0.25 – 2.5 mm ²
Mating cycles	min. 500
Temperature range	-40 °C ... +70 °C
Housing material	Zinc die-cast, nickel-plated
Flammability acc. to UL 94	V0

Identification	Part number	Drawing	Dimensions in mm
----------------	-------------	---------	------------------

Han® PushPull Power 4/0 Panel feed-through

5-poles, 690 V / 16 A
incl. bulkhead housing
and male insert

Rectangular panel cut out
with crimp termination
(Order crimp male contacts
separately)

09 35 231 0311

with Han-Quick Lock®
termination

0.5 ... 2.5 mm²

09 35 232 0311

0.25 ... 1.5 mm²

09 35 234 0311

Circular panel cut out
with crimp termination
(Order crimp male contacts
separately)

09 35 231 0312

with Han-Quick Lock®
termination

0.5 ... 2.5 mm²

09 35 232 0312

0.25 ... 1.5 mm²

09 35 234 0312

Coding element

10 pieces each for device and
cable side
enables 4 times coding without
contact loss

09 35 000 6190

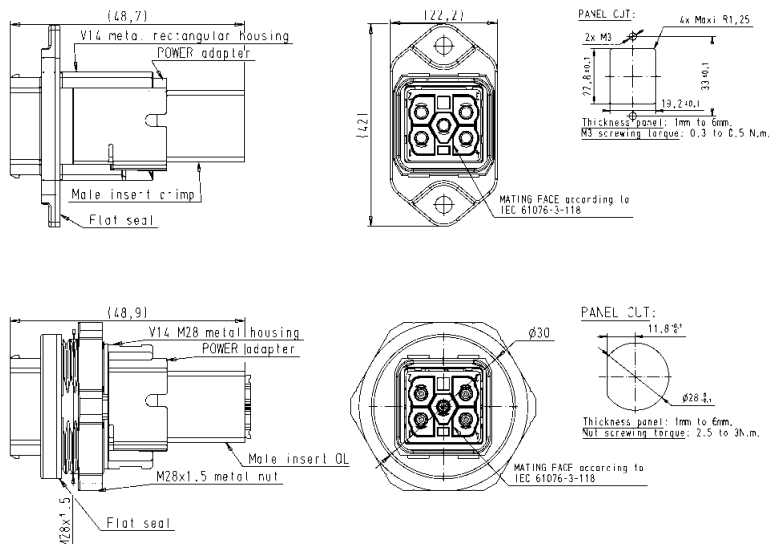



PushPull

Han® PushPull, type acc. to IEC 61 076-3-118
Connector, 5-poles, 690 V, 16 A

Features

- HARTING PushPull technology
- Compact, space-saving design
- Touch-proof
- Cable side: female
 - crimp termination
 - Han-Quick Lock® termination technology
 Field-assembly without special tools
- 4 times coding without contact loss
- NEW: Larger termination cross section for conductors 0.25 - 1.5 mm²

Technical characteristics

Locking	PushPull technology acc. to IEC 61 076-3-117 variant 14
Mating face	acc. to IEC 61 076-3-118
Degree of protection	IP65 / IP67
Number of contacts	4 + PE
Electrical data	16 A 690 V 4 kV 3
acc. to DIN EN 61 984	0.25 – 2.5 mm ²
Termination cross section	min. 500
Mating cycles	-40 °C ... +70 °C
Temperature range	Zinc die-cast, nickel-plated
Housing material	V0
Flammability acc. to UL 94	

Identification	Part number	Drawing	Dimensions in mm
----------------	-------------	---------	------------------

Connector set, metal

incl. housing and female insert

with crimp termination
4 – 11 mm clamp range
Han® P crimp contacts
order separately

09 35 231 0401

with Han-Quick Lock® termination
4 – 11 mm clamp range
for termination cross section 0.5 - 2.5 mm²
for termination cross section 0.25 - 1.5 mm²

09 35 232 0401
09 35 234 0401

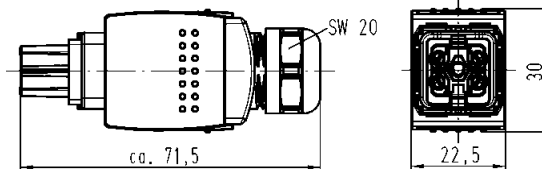



Protection cover IP65 / IP67

09 35 002 5411

Coding pins

09 35 000 6190

Han® PushPull, type acc. to IEC 61 076-3-118 variant 14 Accessories

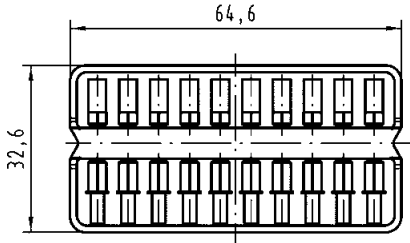
Identification	Part number	Drawing	Dimensions in mm
Crimping tool	09 99 000 0888		
Locator Han P® for crimping tool 09 99 000 0888	09 99 000 0886		
Removal tool Han P®	09 99 000 0319		
Coding pins for 4 times coding without contact loss	09 35 000 6190		

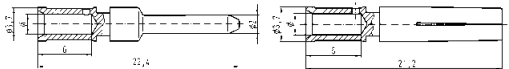
Identification	Part number		Drawing	Dimensions in mm																									
	Male contact	Female contact																											
Crimp contacts Han® P silver plated for 0.5 mm ² for 0.75 mm ² for 1.0 mm ² for 1.5 mm ² for 2.5 mm ²			 <table border="1"> <thead> <tr> <th colspan="2">Wire gauge</th> <th>Ø</th> <th>Stripping length</th> </tr> </thead> <tbody> <tr> <td>for 0.5 mm²</td> <td>AWG 20</td> <td>1.15 mm</td> <td>6 mm</td> </tr> <tr> <td>for 0.75 mm²</td> <td>AWG 18</td> <td>1.30 mm</td> <td>6 mm</td> </tr> <tr> <td>for 1.0 mm²</td> <td>AWG 18</td> <td>1.45 mm</td> <td>6 mm</td> </tr> <tr> <td>for 1.5 mm²</td> <td>AWG 16</td> <td>1.75 mm</td> <td>6 mm</td> </tr> <tr> <td>for 2.5 mm²</td> <td>AWG 14</td> <td>2.25 mm</td> <td>6 mm</td> </tr> </tbody> </table>	Wire gauge		Ø	Stripping length	for 0.5 mm ²	AWG 20	1.15 mm	6 mm	for 0.75 mm ²	AWG 18	1.30 mm	6 mm	for 1.0 mm ²	AWG 18	1.45 mm	6 mm	for 1.5 mm ²	AWG 16	1.75 mm	6 mm	for 2.5 mm ²	AWG 14	2.25 mm	6 mm		
	Wire gauge			Ø	Stripping length																								
	for 0.5 mm ²	AWG 20		1.15 mm	6 mm																								
	for 0.75 mm ²	AWG 18		1.30 mm	6 mm																								
	for 1.0 mm ²	AWG 18		1.45 mm	6 mm																								
	for 1.5 mm ²	AWG 16		1.75 mm	6 mm																								
for 2.5 mm ²	AWG 14	2.25 mm	6 mm																										
	09 35 000 6103	09 35 000 6203																											
	09 35 000 6104	09 35 000 6204																											
	09 35 000 6105	09 35 000 6205																											
	09 35 000 6106	09 35 000 6206																											
	09 35 000 6107	09 35 000 6207																											



Han® PushPull, type acc. to IEC 61076-3-117 variant 14 cable to cable housing

Features

- HARTING PushPull technology
- Ideal for prototyping
- Can be combined with panel feed-throughs for power, data and signal

Technical characteristics

Locking	PushPull technology acc. to IEC 61076-3-117 variant 14
Degree of protection	IP65 / IP67
Outer cable diameter	6.5 ... 9.5 mm / 9 ... 13 mm
Mating cycles	min. 750
Temperature range	-40 °C ... +70 °C
Housing material	Plastic, black
Flammability acc. to UL 94	V0

Identification	Part number	Drawing	Dimensions in mm
<p>Han® PushPull cable to cable housings, plastic (Order housing bulkhead mounting and insert separately)</p> <p>for outer cable diameter 6.5 ... 9.5 mm</p>	09 35 002 0431	<p>2X REMFORM ϕ3x8 TORX screws</p>	
<p>for outer cable diameter 9 ... 13 mm</p>	09 35 002 0433	<p>2X REMFORM ϕ3x8 TORX screws</p>	
<p>Suitable bulkhead housing, plastic</p> <p>for power, 5-poles, 690 V / 16 A, incl. housing bulkhead mounting and insert</p> <p>with crimp termination (Order Han® P crimp male contacts separately)</p>	09 35 231 0331		
<p>with Han-Quick Lock® termination</p> <p>0.5 ... 2.5 mm²</p> <p>0.25 ... 1.5 mm²</p>	09 35 232 0331 09 35 234 0331		
<p>Coding element power</p> <p>10 pieces each for device and cable side</p>	09 35 000 6190		



Housing bulkhead mounting and power females for device integration

Features

- HARTING PushPull technology
- Touch-proof
- Device side: male
 - Solder variant, angled and straight
- AIDA-conform (German Domestic Automobile Manufactures)

Technical characteristics

Locking	PushPull technology
Degree of protection	IP65 / IP67
Number of contacts	4 + PE
Electrical data	16 A 24 V 4 kV 3
acc. to DIN EN 61984	Male insert with solder termination
Termination	min. 500
Mating cycles	-40 °C ... +70 °C
Temperature range	Plastic, black
Housing material	V0
Flammability acc. to UL 94	

Identification

Part number

Drawing

Dimensions in mm

Components device side

Housing bulkhead mounting plastic

09 35 004 0321

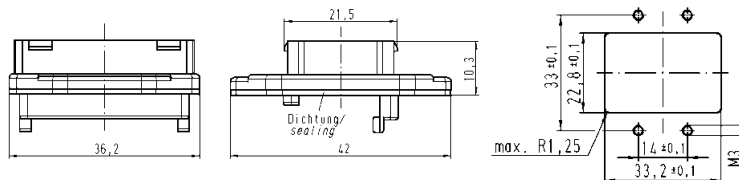

Male insert with solder termination angled

09 35 004 3003

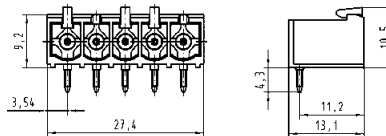

Male insert with solder termination straight

09 35 004 3004

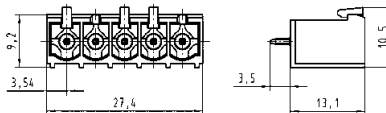

Panel feed-through, plastic
incl. housing and male insert with spring force connection

09 35 431 0331

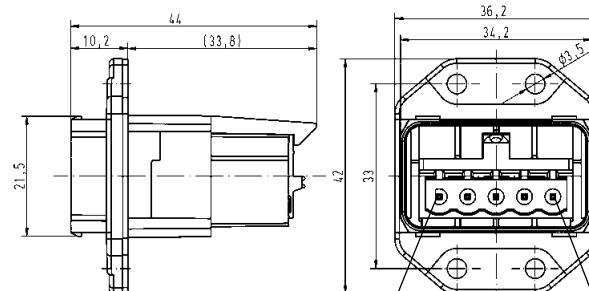

Protection cover IP65 / IP67

09 35 004 5411



Connector, 5-poles, 24 V, 16 A

Features

- HARTING PushPull technology
- Touch-proof
- Cable side: female
 - spring force connection
- AIDA-conform (German Domestic Automobile Manufactures)

Technical characteristics

Locking	PushPull technology
Degree of protection	IP65 / IP67
Number of contacts	4 + PE
Electrical data	
acc. to DIN EN 61984	16 A 24 V 4 kV 3
Termination	Spring force connection
Termination cross section	0.75 ... 2.5 mm ²
Mating cycles	min. 500
Temperature range	-40 °C ... +70 °C
Cable diameter	9 – 13 mm
Housing material	Plastic, black
Flammability acc. to UL 94	V0

Identification

Part number

Drawing

Dimensions in mm

Connector set, plastic

incl. housing and female insert with spring force connection

09 35 431 0421

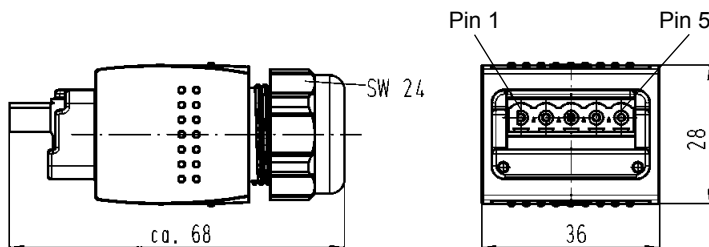

Protection cover IP65 / IP67

09 35 002 5411



Housing bulkhead mounting and power females for device integration

Features

- HARTING PushPull technology
- Touch-proof
- Device side: male
 - Solder variant, angled and straight
- AIDA-conform (German Domestic Automobile Manufactures)

Technical characteristics

Locking	PushPull technology
Degree of protection	IP65 / IP67
Number of contacts	4 + PE
Electrical data	16 A 24 V 4 kV
acc. to DIN EN 61984	Male insert with solder termination
Termination	min. 500
Mating cycles	-40 °C ... +70 °C
Temperature range	Zinc die-cast, nickel plated
Housing material	Plastic, black (female)

Identification	Part number	Drawing	Dimensions in mm
Components device side Housing bulkhead mounting metal	09 35 004 0301		Panel cut out
Male insert with solder termination angled and with fixed coding	09 35 004 3003		
Male insert with solder termination straight and with fixed coding	09 35 004 3004		
Panel feed-through, metal incl. housing and male insert with spring force connection and with fixed coding with variable coding	09 35 431 0311 09 35 431 0313		
Protection cover IP65 / IP67	09 35 004 5401		



PushPull

Han® PushPull L Power 4/0 Genderchanger Metal
 Han® PushPull L Power 4/0 H-distributor Metal

Features

- High degree of protection IP65 / IP67
- Robust metal housing
- Standard PROFINET component of the German automotive production
- Allows usage of different cable types (Type B,C) e.g. in robots application
- Extension of cords according to PROFINET guideline
- 4-way-distribution of power signals

Technical characteristics

Connector	Han® PushPull L Power 4/0
Locking	PushPull technology
Electrical transmission	16 A / 24 V
Number of contacts	5
Mating cycles	min. 500
Housing material	Aluminium anodized
Dimensions	83.4 x 62 x 40.7 mm (unmated)
Degree of protection acc. to DIN 60529	IP65 / IP67 (mated)
Mounting	Wall mountable with 4 screws (type M5)
Temperature range	-20 °C ... +50 °C
Maximum permissible humidity	30 % ... 95 % (no condensation)

Identification

Part number

Drawing

Dimensions in mm

Han® PushPull L Power 4/0 Genderchanger metal
 including housing and printed board with 2 x male insert with solder termination

09 35 431 0501

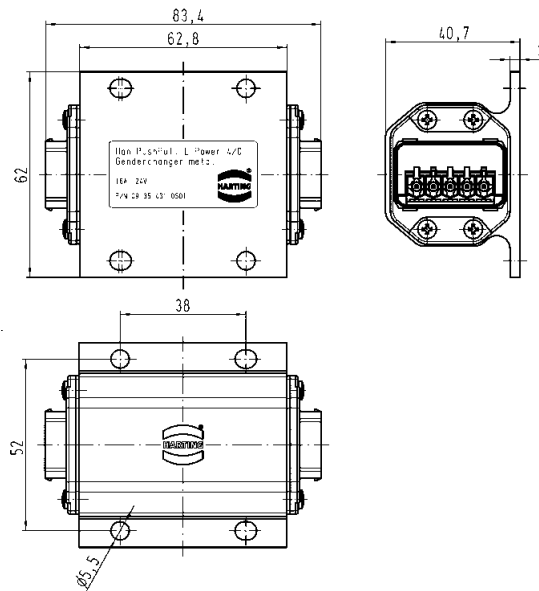

Han® PushPull L Power 4/0 AIDA H-distributor 4-way metal
 including housing and printed board with 4 x male insert with solder termination

61 12 204 0001

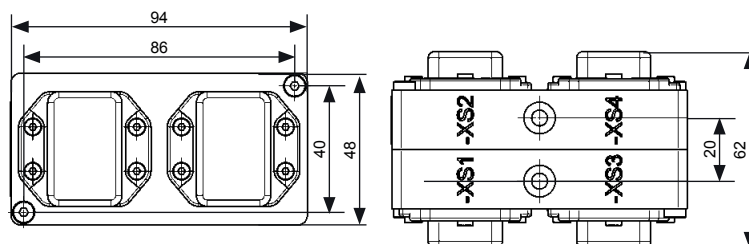



Han® PushPull L Power 4/0 Coupling Metal

Features

- High degree of protection IP65 / IP67
- Robust metal housing
- Standard PROFINET component of the German automotive production
- Extension of cords according to PROFINET guideline
- For an easy robot termination and a fast exchange of tube packages

Technical characteristics

Locking	PushPull technology
Electrical transmission	16 A / 24 V
Number of contacts	5
Mating cycles	min. 500
Housing material	Aluminium die-cast
Degree of protection acc. to DIN 60529	IP65 / IP67
Temperature range	-40 °C ... +70 °C

Identification

Part number

Drawing

Dimensions in mm

Han® PushPull L Power 4/0 Coupling metal

including housing, contact insert Power L, bulkhead housing and cable gland

61 04 201 1085

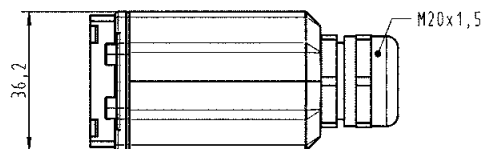
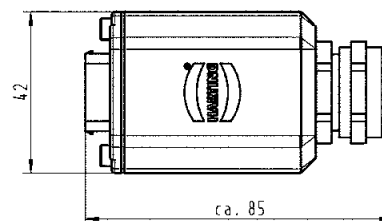

Fixing flange

61 04 600 0183

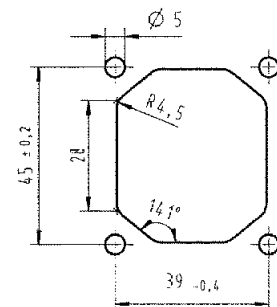
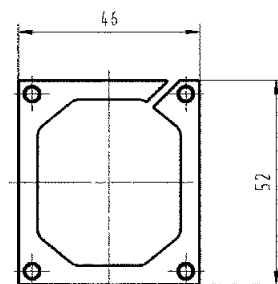



Connector, 5-poles, 24 V, 16 A

Features

- HARTING PushPull technology
- Robust design
- Cable side: female
 - spring force connection
- AIDA-conform (German Domestic Automobile Manufactures)
- Enlarged size for an optimized connection of 2.5 mm² conductor cross sections

Technical characteristics

Locking	PushPull technology
Degree of protection	IP65 / IP67
Number of contacts	4 + PE
Electrical data	
acc. to DIN EN 61984	16 A 24 V 4 kV 3
Termination	Spring force connection
Termination cross section	0.75 ... 2.5 mm ²
Mating cycles	min. 100
Temperature range	-40 °C ... +70 °C
Cable diameter	9 - 13 mm
Housing material	Zinc die-cast, nickel plated

Identification

Part number

Drawing

Dimensions in mm

Connector set, metal

incl. housing and female insert with spring force connection and

with fixed coding
9 - 13 mm clamp range

09 35 433 0401

with variable coding
9 - 13 mm clamp range

09 35 434 0401

Protection cover IP65 / IP67

09 35 002 5411

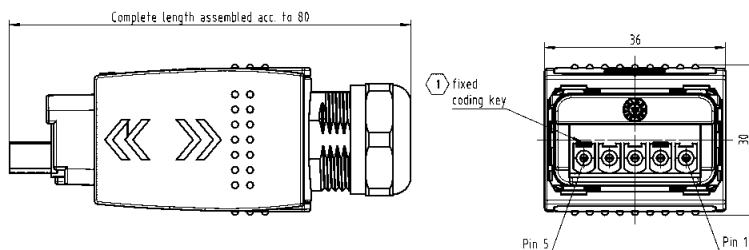

03. Circular Connectors



Circular connectors represent a widespread industrial standard for wiring sensors and actuators installed in the field. HARTING offers a portfolio of circular connectors with M8, M12, M 23, 7/8" thread and Han-Max® which are attuned to meet the requirements of industrial applications. In addition to the ready-to-use system cables, HARTING offers connectors equipped with HARAX® quick connection technology for in situ field assembly. In addition, HARTING is continuing the development of enhanced circular connectors for new applications. HARTING is offering the M12 connector for the electrical and optical cabling for Fast Ethernet applications.

Application profile:

CONNECTION TYPE		ENVIRONMENT		APPLICATION						
Board to Board	Cable/Wire to Board	IP20	IP65 / IP67	Data	Signal	Power	high performance			
							Data transfer rate	Shielding	Number of contacts, contact density	Voltage, working current
Cable termination			PCB termination			Application standard				
Han-Quick Lock®	IDC HARAX®	Crimp	THT	SMC	SMT					
Screw			Press-in			Housing integration				
Cage clamp						Separate housing		Integrated housing		
Axial screw										

Contents

	Page
M8	03.08
M12 A coded	03.20
M12 B coded	03.58
M12 D coded	03.80
<i>har</i> -speed M12 data connectors X coded	03.105
M12 PushPull	03.116
INOX – Solutions for extreme demands	03.126
M12 with conduit	03.130
7/8" HARAX®	03.132
HARAX® panel feed-through	03.142
Han-Max®	03.147

Standardized circular connectors with M8, M12, M 23, 7/8“ thread and Han-Max® are in widespread use in the installation of machines and systems.

HARTING offers a portfolio of angled and straight M8, M12, Han® R 23 and 7/8” connectors which are attuned to meet all relevant automation requirements. The housings are available as plastic and as metal variant. In addition to the standard circular connectors for sensors/actuators, HARTING is offering standardized circular connectors such as the M12 and Han-Max® variants to meet the special requirements of communication technology (Ethernet, Ethernet/IP, PROFINET, PROFIBUS, Devicenet and CAN).

The HARTING product range comprises connectors, ready-to-use patch cables and corresponding accessories.

The easy-to-handle HARAX® quick connection technology is available for the in situ assembly of M8 and M12 connectors and does not require the use of special tools. The portfolio of circular connectors is rounded off by the Han® R 23 connector family. HARTING’s comprehensive and user-friendly circular connector range enables cost-effective and quick realization of all wiring and communication tasks in automation projects.

APPLIANCE INTEGRATION:

In order to support the implementation of appliances with degree of protection IP65 / IP67, HARTING offers panel feed-through devices with ready-to use patch cables and female contact modules for direct mounting on PCBs.



QUICK CONNECTION WITH HARAX®:

The HARTING HARAX® quick connection technology is an ideal solution for the in situ assembly of M8/M12 connectors. Users only have to strip the cable insulation, insert the conductors, and screw the connector together in order to produce a gas-proof and vibration resistant connection. HARAX® is a universal technology deployed in diverse connector series to wire data, signal and power lines and represents the current standard connection for Fieldbus and Fast Ethernet.



ASSEMBLED SYSTEM CABLES:

HARTING offers a comprehensive range of ready-to-use M8/M12 system cables for the quick wiring of sensors and actuators. HARTING also offers ready-to-use and tested system cables for special Ethernet communication such as PROFINET and Ethernet/IP. HARTING also provides custom patch cables which are also available as overmoulded versions. The range of solutions comprises shielded and non-shielded cables with diverse structures, as required in drag chain applications, for example.



M12 FEMALE SOCKETS FOR PCB MOUNTING:

Straight and angled contact inserts are available for direct soldering on PCBs. HARTING has developed special shielded contact inserts category 5 to ISO/IEC 11801 for Ethernet technology which meet the stringent requirements for railway applications.



Specifications

IEC 60352-4, IEC 61076-2-104, IEC 61076-2-101, IEC 61076-2-109,



M8 circular connectors, mating face acc. to IEC 61076-2-104

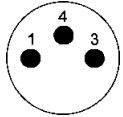

Male, 3 poles

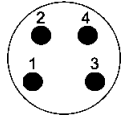

Male, 4 poles

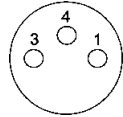

Female, 3 poles

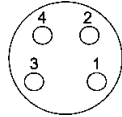

Female, 4 poles

M12 circular connectors, mating face acc. to IEC 61076-2-101

A-coding



Male, 3 poles

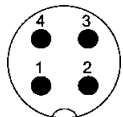

Male, 4 poles

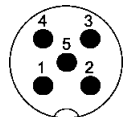

Male, 5 poles

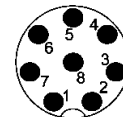

Male, 8 poles



Male, 12 poles

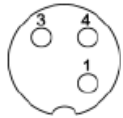

Female, 3 poles

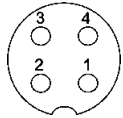

Female, 4 poles

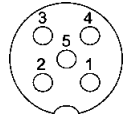

Female, 5 poles

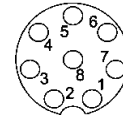

Female, 8 poles

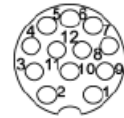

Female, 12 poles

B-coding



Male, 4 poles

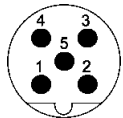

Male, 5 poles

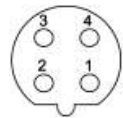

Female, 4 poles

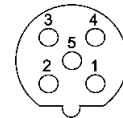

Female, 5 poles

D-coding

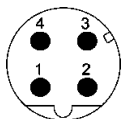

Male, 4 poles

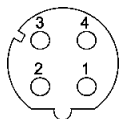

Female, 4 poles

X-coding, mating face acc. to IEC 61076-2-109

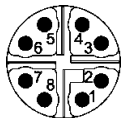

Male, 8 poles

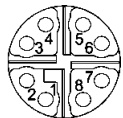

Female, 8 poles

7/8"

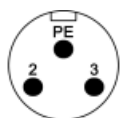

Male, 2 + PE

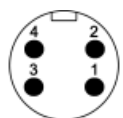

Male, 4 poles

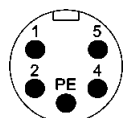

Male, 4 + PE

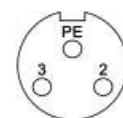

Female, 2 + PE

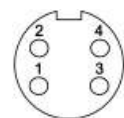

Female, 4 poles

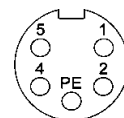

Female, 4 + PE

X-coding, mating face acc. to IEC 61076-2-109

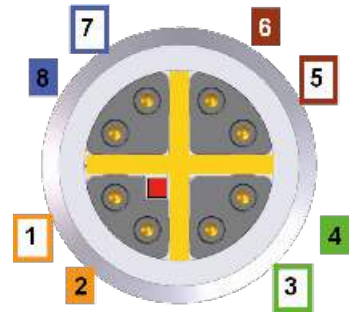

8 poles pin assignment

Signals		Pin assignment			Cable		
1/10Gbit	10/100 Mbit	RJ45	M12 D-coded	M12 X-coded	4-wire	568A	568B
BI_DA+	TxData+	1	1	1	yellow	white/green	white/orange
BI_DA-	TxData-	2	3	2	orange	green	orange
BI_DB+	RxData+	3	2	3	white	white/orange	white/green
BI_DC+	-	4	-	8		blue	blue
BI_DC-	-	5	-	7		white/blue	white/blue
BI_DB-	RxData-	6	4	4	blue	orange	green
BI_DD+	-	7	-	5		white/brown	white/brown
BI_DD-	-	8	-	6		brown	brown

Adapter M12/RJ45

4 poles pin assignment

10/100 Mbit	RJ45	M12 D-coded	4-wire
TxData+	1	1	yellow
TxData-	2	3	orange
RxData+	3	2	white
RxData-	6	4	blue

Stromlaufplan
circuit diagram

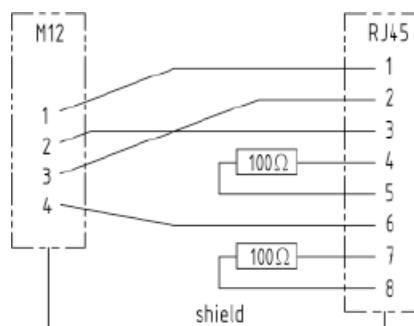

Adapter M12/RJ45

8 poles pin assignment

M12	RJ45
1	1
2	2
3	3
4	6
5	7
6	8
7	5
8	4

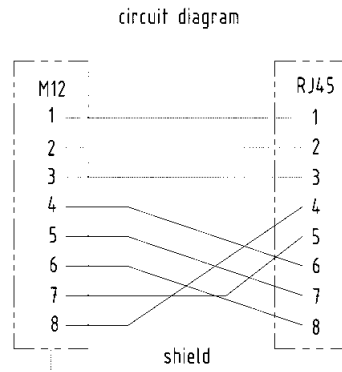

Gender changer

4 poles



schematic diagram

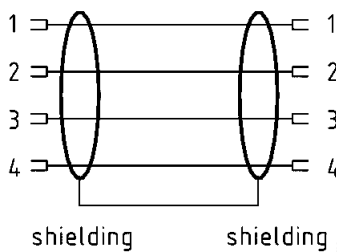

4 poles / 8 poles



schematic diagram

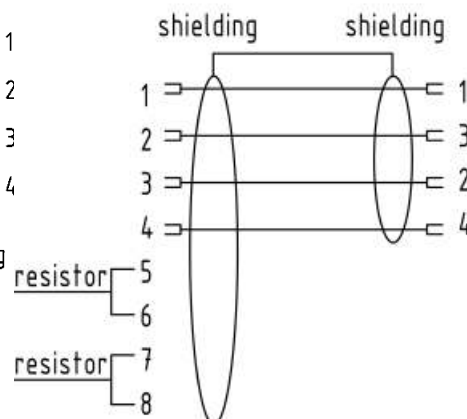

8 poles



schematic diagram

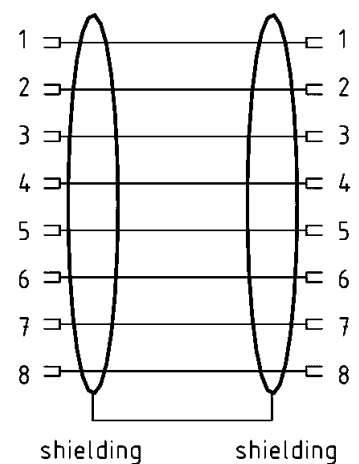

M8 HARAX[®] cable connector



Specifications IEC 60352-4

Approval 

Mating face

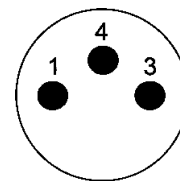

A-coding
Mating face
acc. to IEC 61076-2-101



Technical characteristics M8 HARAX[®]

Type M8	HARAX [®] M8-XS	HARAX [®] M8-S
---------	--------------------------	-------------------------

General data

Conductor cross section	0.1 - 0.14 mm ² AWG 27-26	0.14 - 0.34 mm ² AWG 26-22
Diameter of individual strands	≥ 0.05 mm	≥ 0.1 mm
Conductor insulation material	PVC / PP / TPE	PVC / PP / TPE
Conductor diameter	0.6 - 1.0 mm	1.0 - 1.6 mm
Cable diameter	1.9 - 2.5 mm 2.5 - 3.5 mm	2.5 - 5.1 mm
Temperature range	-40 °C ... +85 °C	-40 °C ... +85 °C
Temperature during connection	-5 °C ... +50 °C	-5 °C ... +50 °C
Degree of protection	IP67	IP67
Mating cycles	100	100
Recommended tightening torque / Hexagonal wrench	0.4 Nm / SW 9	0.4 Nm / SW 9

Electrical characteristics

Rated current	2 A	4 A
Rated voltage	32 V	32 V
Rated impulse voltage	1.5 kV	1.5 kV
Contact resistance	10 mΩ	10 mΩ
Insulation resistance	10 ⁸ Ω	10 ⁸ Ω
Pollution degree	3	3
Overvoltage category	3	3
Isolation group	1	1

Materials

Contact material	Copper alloy	Copper alloy
Contact plating	Gold	Gold
Contact carrier material	PA	PA
Housing material	PA, zinc die-cast	PA, zinc die-cast

Technical characteristics M8

Current carrying capacity The current carrying capacity is limited by maximum temperature of materials for inserts and contacts including terminals. The current capacity-curve is valid for continuous, not interrupted current-loaded contacts of connectors when simultaneous power on all contacts is given, without exceeding the maximum temperature.

Control and test procedures according to DIN IEC 60512-5.

M8-XS, 3 poles 1 = Wire gauge 0.1 mm²
 M8-S, 3 poles 2 = Wire gauge 0.14 mm²

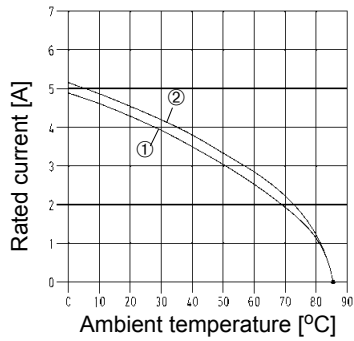

M8-S, 4 poles 1 = Wire gauge 0.25 mm²
 2 = Wire gauge 0.34 mm²

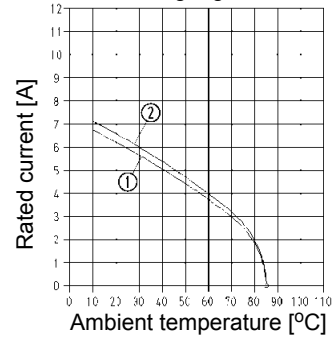

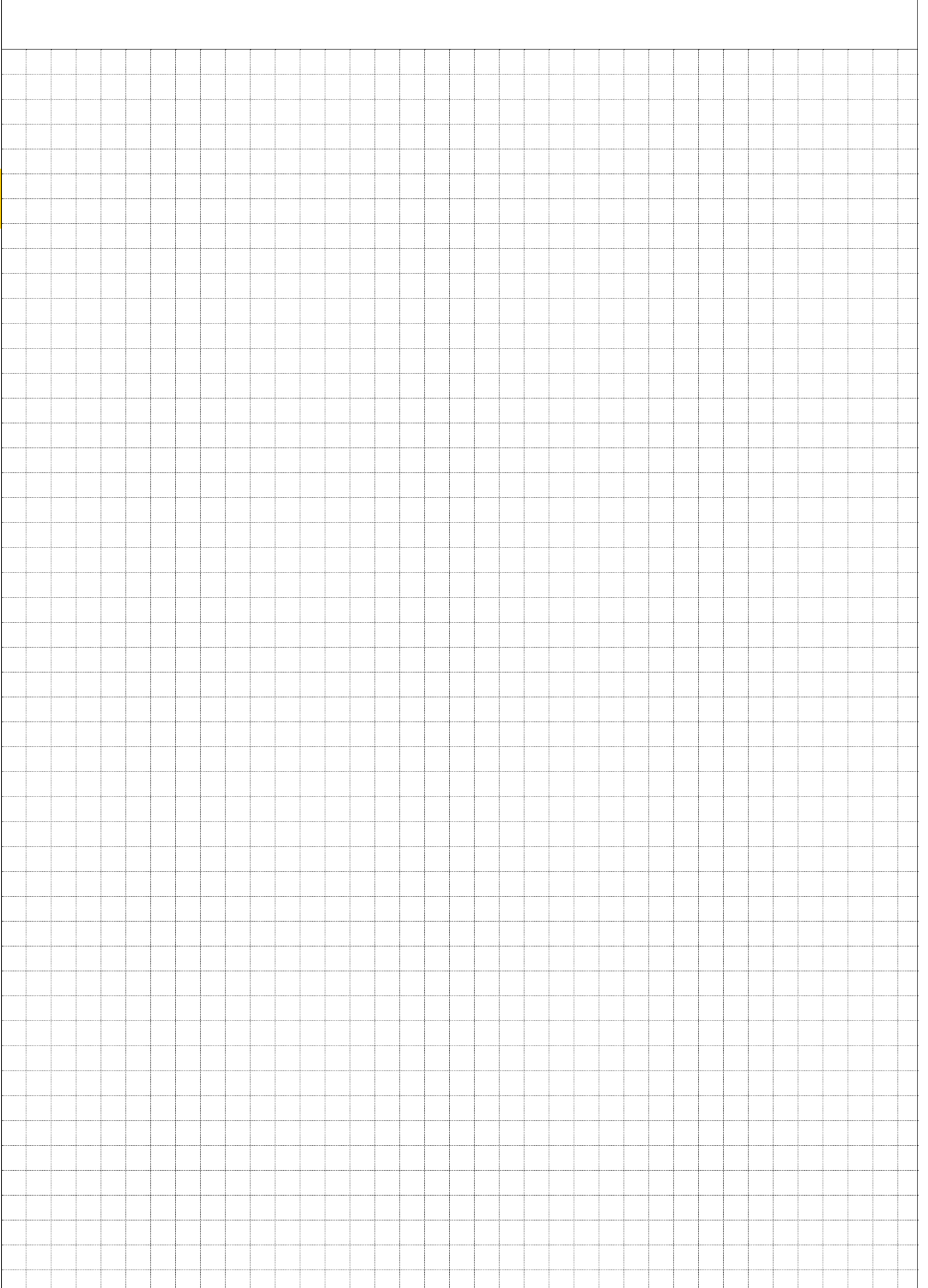



Mating face

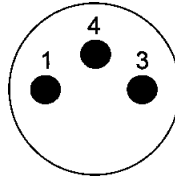

A-coding
Mating face
acc. to IEC 61076-2-101



Applications / Advantages

- Actor and sensor applications
- Unshielded versions
- HARAX® rapid termination
- Overmoulded system cables in various lengths
- Robust design, quick assembly

Identification

Part number

Drawing

Dimensions in mm

HARAX® M8-XS



Male
straight version, 3 poles
for 0.1 - 0.14 mm²

21 02 159 1305

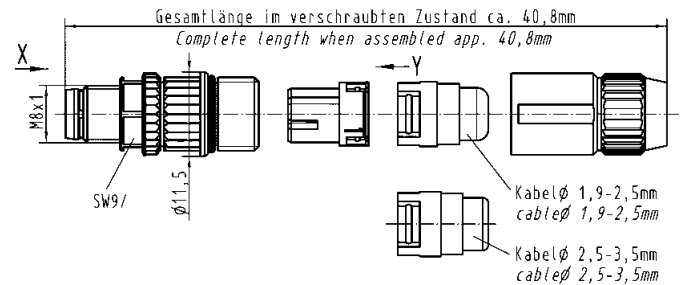



Mating face

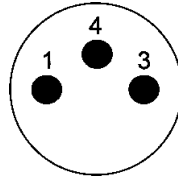

A-coding
Mating face
acc. to IEC 61076-2-101



Identification	Part number	Drawing	Dimensions in mm
----------------	-------------	---------	------------------

HARAX® M8-S



Male
straight version, 3 poles
for 0.14 - 0.34 mm²

21 02 151 1305

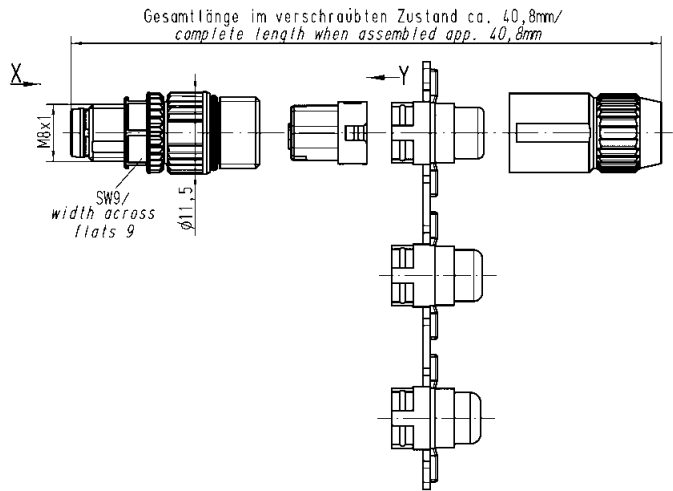

Male
straight version, 4 poles
for 0.14 - 0.34 mm²

21 02 151 1405

View mating side:
3 poles, male



View mating side:
4 poles, male





Mating face

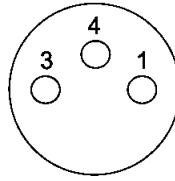

A-coding
Mating face
acc. to IEC 61076-2-101



Identification

Part number

Drawing

Dimensions in mm

HARAX® M8-S



Female
straight version, 3 poles
for 0.14 - 0.34 mm²

21 02 151 2305

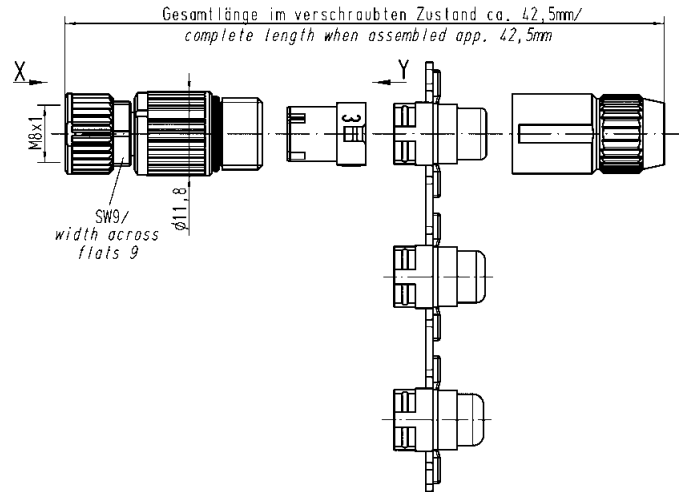

Female
straight version, 4 poles
for 0.14 - 0.34 mm²

21 02 151 2405

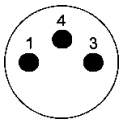

Male, 3 poles

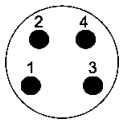

Male, 4 poles

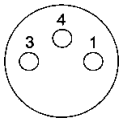

Female, 3 poles

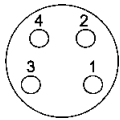

Female, 4 poles



Technical characteristics

System cables with M8 circular connectors without PE

	3 poles		4 poles	
	PVC	PUR	PVC	PUR
Rated voltage	max. 60 V AC/DC	max. 60 V AC/DC	max. 30 V AC/DC	max. 30 V AC/DC
Rated current / contact	max. 3 A at +40 °C	max. 3 A at +40 °C	max. 3 A at +40 °C	max. 3 A at +40 °C
Screw locking	M8x1, self securing	M8x1, self securing	M8x1, self securing	M8x1, self securing
Recommended torque	0.4 Nm	0.4 Nm	0.4 Nm	0.4 Nm
Temperature range (working and storage)	-30 °C ... +80 °C	-30 °C ... +80 °C	-30 °C ... +80 °C	-30 °C ... +80 °C
Degree of protection	IP67	IP67	IP67	IP67
Number of wires / wire gauge	3 x 0.25 mm ²	3 x 0.25 mm ²	3 x 0.25 mm ²	3 x 0.25 mm ²
Conductor insulation	PVC (bn, bu, bk)	PVC (bn, bu, bk)	PVC (bn, wh, bu, bk)	PVC (bn, wh, bu, bk)
Arrangement of insulated strands	32 x Ø 0.1 mm	32 x Ø 0.1 mm	32 x Ø 0.1 mm	32 x Ø 0.1 mm
Sheath	PVC	PUR (UL, CSA)	PVC	PUR (UL, CSA)
Sheath colour	grey	black	grey	black
Outer diameter	Ø 4.40 ± 0.15 mm	Ø 4.40 ± 0.15 mm	Ø 4.70 ± 0.15 mm	Ø 4.40 ± 0.15 mm
Useable as trailing cable	no	yes	no	yes
Halogen free acc. to	–	DIN VDE 0472 part 815	–	DIN VDE 0472 part 815
Flame retardant acc. to	DIN EN 60 332-2-2	cUL20549	DIN EN 60 332-2-2	cUL20549
Oil-resistant	–	–	–	–

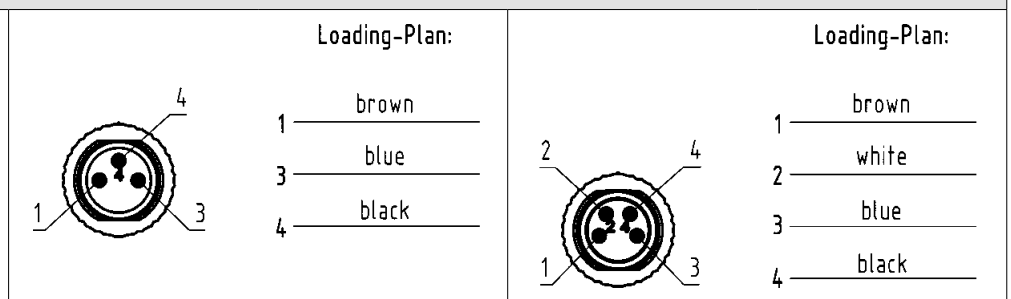

M8 System cables 3 and 4 poles

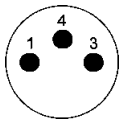

Male, 3 poles

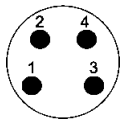

Male, 4 poles

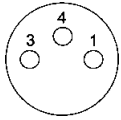

Female, 3 poles

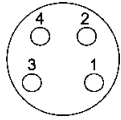

Female, 4 poles



Circular Connectors

Part number definition



- Connector 1**
- 80 Male straight
 - 81 Female straight
 - 82 Male angled
 - 83 Female angled

- Connector 2**
- 00 No connector
 - 80 Male straight
 - 81 Female straight
 - 82 Male angled
 - 83 Female angled

- Number of contacts**
- 3 3 poles
 - 4 4 poles

- Cable material**
- 80 PVC (3 poles)
 - 81 PVC (4 poles)
 - 88 PUR (3 poles)
 - 89 PUR (4 poles)

- Preferred length***
- 005 0.5 m
 - 010 1.0 m
 - 015 1.5 m
 - 020 2.0 m
 - 050 5.0 m
 - 075 7.5 m
 - 100 10.0 m

* Other length on request

Mating face

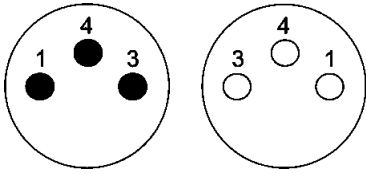

A-coding
Mating face
acc. to IEC 61076-2-101



Identification

Part number

Drawing

Dimensions in mm

M8 Circular connectors

Female angled, with LED
Male straight

Length:	Part number
0.3 m	21 02 454 7301
0.6 m	21 02 454 7302
1.0 m	21 02 454 7303
1.5 m	21 02 454 7304
2.0 m	21 02 454 7305

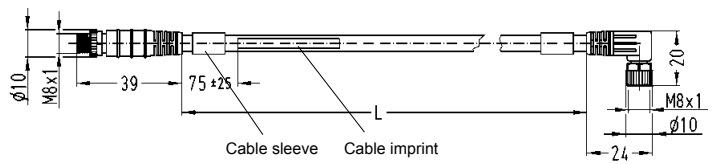

View mating side



Schematic diagram

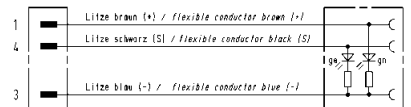

Mating face

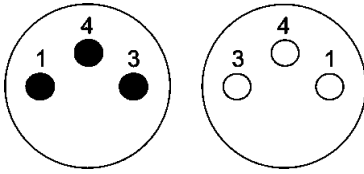

A-coding
Mating face
acc. to IEC 61076-2-101



Identification

Part number

Drawing

Dimensions in mm

M8 Circular connectors
Female angled, with LED
pre-assembled on one end

Length:	Part number
1.5 m	21 02 554 7301
3.0 m	21 02 554 7302
5.0 m	21 02 554 7303
7.5 m	21 02 554 7304
10.0 m	21 02 554 7305

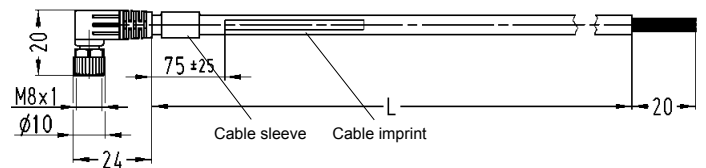

Schematic diagram

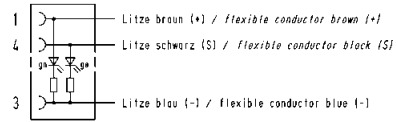

View mating side

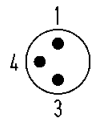

M8 Panel feed-through



Circular Connectors



Mating face

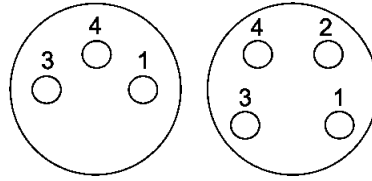

A-coding
Mating face
acc. to IEC 61076-2-101



Identification	Part number	Drawing	Dimensions in mm
----------------	-------------	---------	------------------

M8 Panel feed-through

Female
A-coding,
50 cm conductors, 0.5 mm², 3 poles

Panel thickness
min. 1.5 mm

21 02 357 6305

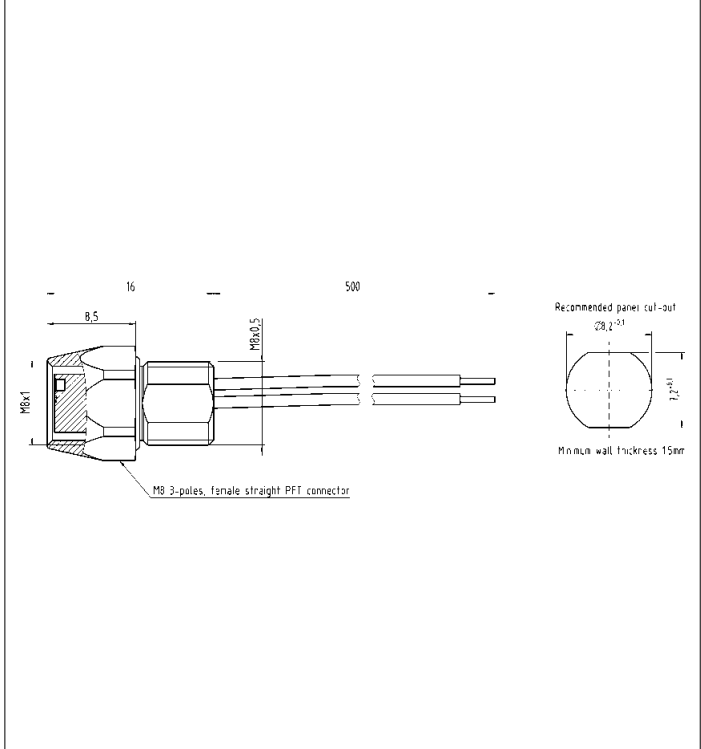





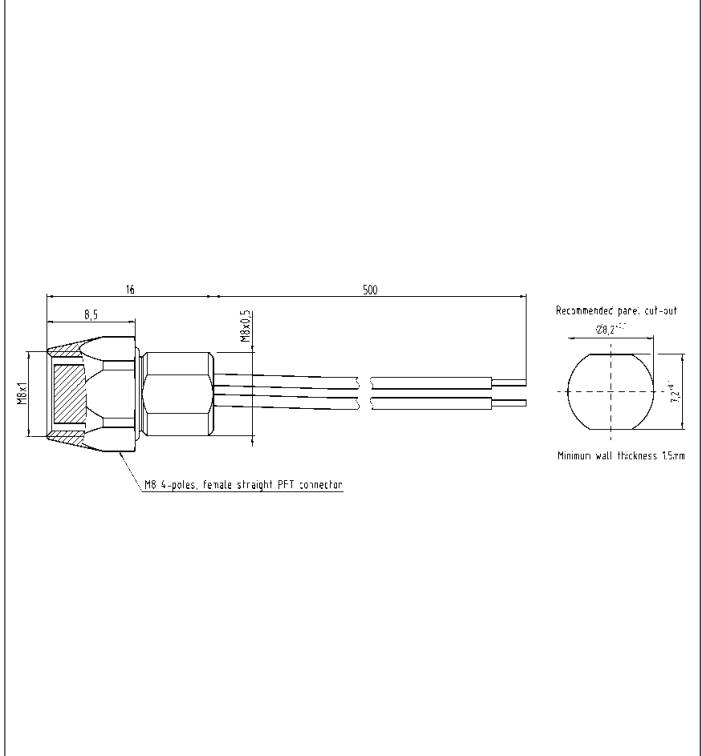

M8 Panel feed-through

Female
A-coding,
50 cm conductors, 0.5 mm², 4 poles

Panel thickness
min. 1.5 mm

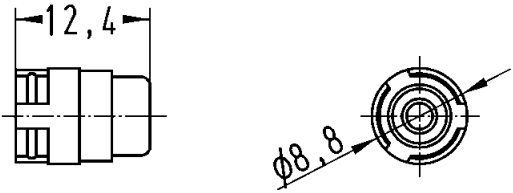
21 02 357 6405

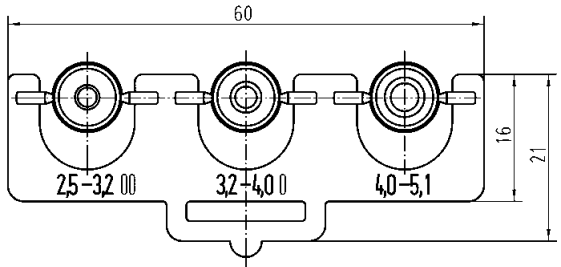

Identification	Part number	Drawing	Dimensions in mm
<p>Seal M8</p> <p>for 1.9 - 2.5 mm cable Ø for 2.5 - 3.5 mm cable Ø for 4.2 - 5.4 mm cable Ø</p> 	<p>21 01 010 2016 21 01 010 2008 21 01 010 2005</p>		
<p>Set of seals for HARAX® M8-S</p> <p>for 2.5 - 3.2 mm cable Ø for 3.2 - 4.0 mm cable Ø for 4.0 - 5.1 mm cable Ø</p> 	<p>21 01 010 2013</p>		
<p>M8 dynamometric screwdriver</p> <p>Tightening torque 0.4 Nm</p>	<p>SW 9 09 99 000 0380</p>		

Specifications IEC 60352-4

Approval



Mating face

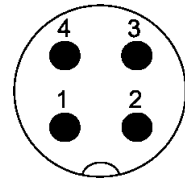

A-coding
Mating face
acc. to IEC 61076-2-101



Technical characteristics M12 – A-coding

Type M12 A-coded	HARAX® M12-S	HARAX® M12 angled	HARAX® M12 L 3 poles, 4 poles
------------------	--------------	-------------------	----------------------------------

General data

Conductor cross section	0.14 - 0.34 mm ² AWG 26-22	0.25 - 0.5 mm ² AWG 24/7-20	0.34 - 0.75 mm ² AWG 22-18
Diameter of individual strands	≥ 0.1 mm	≥ 0.1 mm	≥ 0.1 mm
Conductor insulation material	PVC / PP / TPE	PVC	PVC
Conductor diameter	1.0 - 1.6 mm	1.2 - 1.6 mm	1.6 - 2.0 mm 2.0 - 2.6 mm
Cable diameter	2.9 - 4.0 mm 4.0 - 5.1 mm	4 - 5.1 mm	6 - 8 mm
Temperature range	-40 °C ... +85 °C	-40 °C ... +85 °C	-40 °C ... +85 °C
Temperature during connection	-5° C ... +50 °C	-5 °C ... +50 °C	-5 °C ... +50 °C
Degree of protection	IP67	IP67	IP65 / 67
Mating cycles	100	100	100
Tightening torque connector / hexagonal wrench	0.6 Nm / SW 13	0.6 Nm / SW 13	0.6 Nm / SW 17

Electrical characteristics

Rated current	4 A	4 A	6 A
Rated voltage	32 V	32 V	50 V
Rated impulse voltage	1.5 kV	1.5 kV	1.5 kV
Contact resistance	10 mΩ	10 mΩ	10 mΩ
Insulation resistance	10 ⁸ Ω	10 ⁸ Ω	10 ⁸ Ω
Pollution degree	3	3	3
Overvoltage category	3	3	3
Isolation group	1	1	1

Materials

Contact material	Brass	Brass	Brass
Contact plating	Gold	Gold	Gold
Contact carrier material	PA reinforced	PA	PA unreinforced
Housing material	PA reinforced	PA	PA unreinforced

Specifications IEC 60352-4

Approval



Mating face

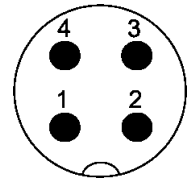

A-coding
Mating face
acc. to IEC 61076-2-101

Circular Connectors

Technical characteristics M12 – A-coding

Type M12 A-coded	HARAX® M12-L 5 poles	HARAX® M12 L shielded	M12 Crimp
------------------	-------------------------	--------------------------	-----------

General data

Conductor cross section	0.34 - 0.5 mm ² AWG 22-20	0.14 - 0.34 mm ² AWG 26-22	0.14 - 0.75 mm ² AWG 26-18
Diameter of individual strands	≥ 0.1 mm	≥ 0.1 mm	X
Conductor insulation material	PVC	PVC	X
Conductor diameter	1.2 - 2.0 mm	1.2 - 1.6 mm	2.0 - 2.3 mm
Cable diameter	6 - 8 mm	4.5 - 8.8 mm	4.5 - 8.8 mm
Temperature range	-40 °C ... +85 °C	-40 °C ... +85 °C	-40 °C ... +85 °C
Temperature during connection	-5 °C ... +50 °C	-5 °C ... +50 °C	-5 °C ... +50 °C
Degree of protection	IP65 / 67	IP65 / 67	IP67
Mating cycles	100	100	500
Tightening torque connector / hexagonal wrench	0.6 Nm / SW 17	0.6 Nm / SW 17	0.5 Nm / SW 17

Electrical characteristics

Rated current	4 A	4 A	4 A
Rated voltage	50 V	50 V	250 V
Rated impulse voltage	1.5 kV	1.5 kV	1.5 kV
Contact resistance	10 mΩ	10 mΩ	10 mΩ
Insulation resistance	10 ⁸ Ω	10 ⁸ Ω	10 ⁸ Ω
Pollution degree	3	3	3
Overvoltage category	3	3	3
Isolation group	1	1	1

Materials

Contact material	Brass	Brass	Brass
Contact plating	Gold	Gold	Gold
Contact carrier material	PA unreinforced	PA unreinforced	PA
Housing material	PA unreinforced	PA unreinforced	PA

Technical characteristics M12 – A-coding

Current carrying capacity The current carrying capacity is limited by maximum temperature of materials for inserts and contacts including terminals. The current capacity-curve is valid for continuous, not interrupted current-loaded contacts of connectors when simultaneous power on all contacts is given, without exceeding the maximum temperature.

Control and test procedures according to DIN IEC 60512-5.

M12-S, 4 poles 1 = Wire gauge 0.25 mm²
2 = Wire gauge 0.34 mm²

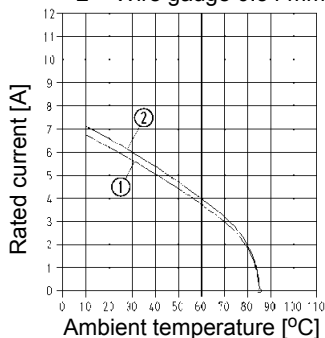

M12-L, 3 poles, 4 poles 1 = Wire gauge 0.34 mm²
2 = Wire gauge 0.75 mm²

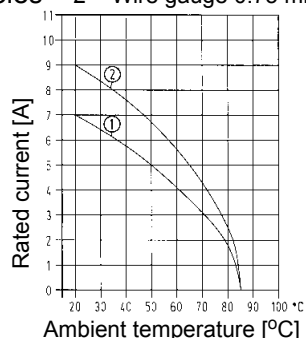

M12, 4 poles, angled 1 = Wire gauge 0.25 mm²
2 = Wire gauge 0.5 mm²

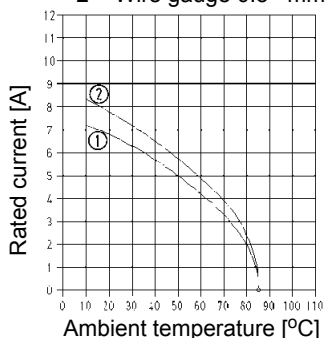

M12L, 5 poles 1 = Wire gauge 0.25 mm²
2 = Wire gauge 0.34 mm²

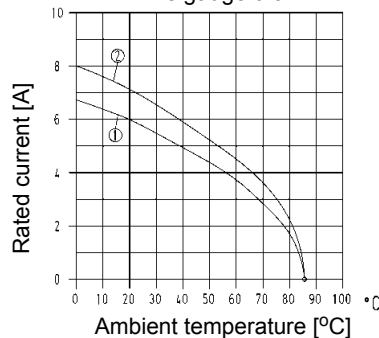

M12, Crimp 1 = Wire gauge 0.34 mm² /
0.5 mm²

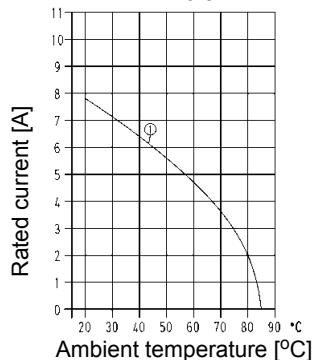

Technical characteristics M12 – A-coding, PCB adapter

M12, A-coding, straight, male, 4 poles
Wire gauge 0.5 mm²

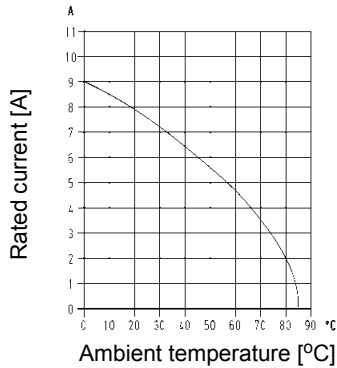

M12, A-coding, straight, female, 4 poles
Wire gauge 0.75 mm²

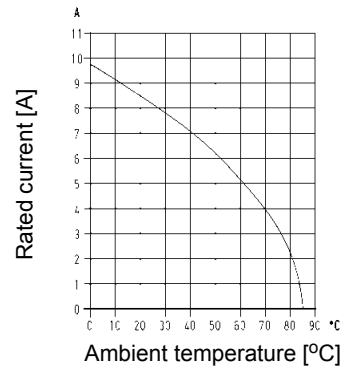

M12, A-coding, straight, female, 5 poles
Wire gauge 0.5 mm²

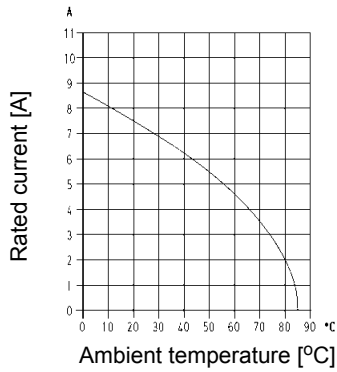

M12, A-coding, straight, male, 5 poles
Wire gauge 0.5 mm²

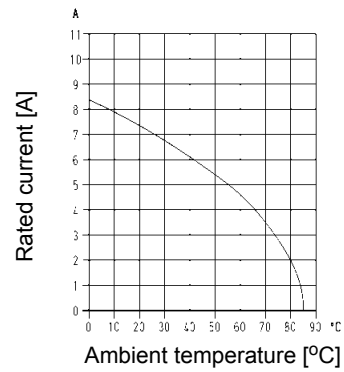



Mating face

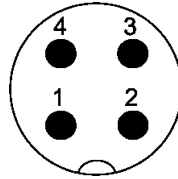

A-coding
Mating face
acc. to IEC 61076-2-101



Applications / Advantages

- Actor and sensor applications
- Shielded and unshielded versions
- Available with crimp resp. HARAX® rapid termination, or as overmoulded system cable in various lengths
- Robust design, quick assembly

Identification	Part number	Drawing	Dimensions in mm
<p>HARAX® M12-S</p> <p>Male straight version 4 poles, 0.14 - 0.34 mm²</p>	21 03 111 1405	<p>Gesamtlänge im verschraubten Zustand ca. 46,75mm complete length when assembled app. 46,75mm</p>	
<p>Male straight version 4 poles, 0.25 - 0.5 mm²</p>	21 03 112 1405	<p>Gesamtlänge im verschraubten Zustand ca. 56,8mm complete length when assembled app. 56,8mm</p> <p>SW13 width across flats 13</p> <p>Ø16,7</p>	



Mating face

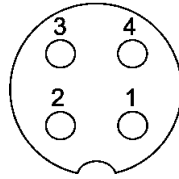

A-coding
Mating face
acc. to IEC 61076-2-101



Identification	Part number	Drawing	Dimensions in mm
----------------	-------------	---------	------------------

HARAX® M12-S



Female straight version
4 poles, 0.14 - 0.34 mm²

21 03 111 2405

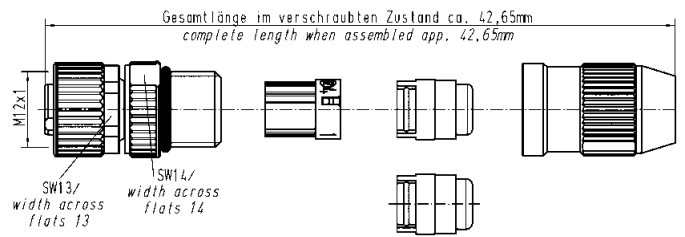

Female straight version
4 poles, 0.25 - 0.5 mm²

21 03 112 2405

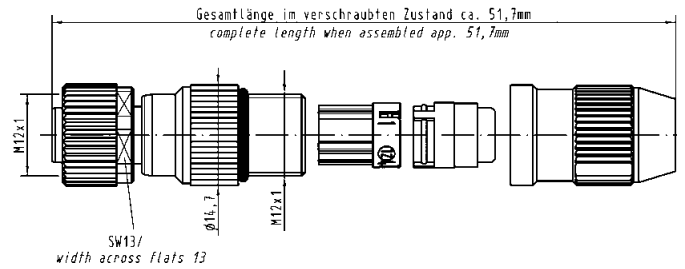



Mating face

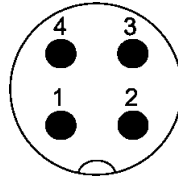

A-coding
Mating face
acc. to IEC 61076-2-101



Identification	Part number	Drawing	Dimensions in mm
----------------	-------------	---------	------------------

HARAX® M12



Male
angled version
4 poles

21 01 140 5081

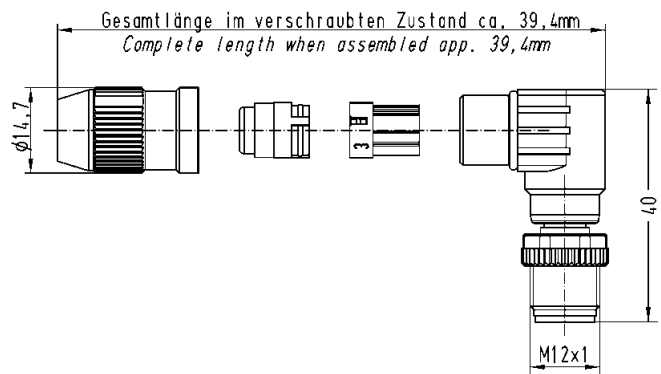



Mating face

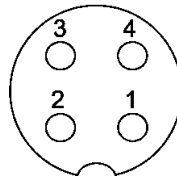

A-coding
Mating face
acc. to IEC 61076-2-101



Identification

Part number

Drawing

Dimensions in mm

HARAX® M12



Female
angled version
4 poles

21 01 140 5091

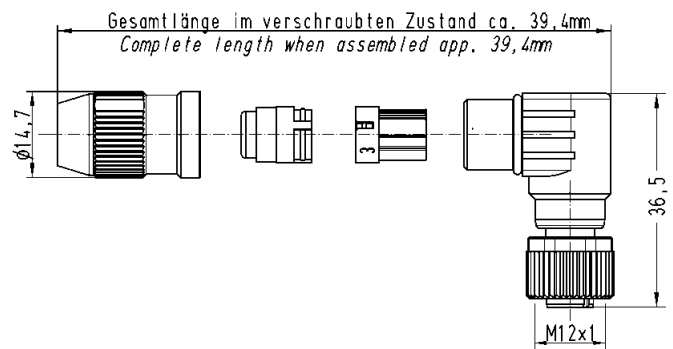



Mating face

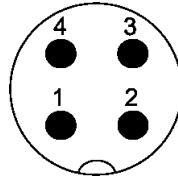

A-coding
Mating face
acc. to IEC 61076-2-101



Circular Connectors

Identification	Part number	Drawing	Dimensions in mm
----------------	-------------	---------	------------------

HARAX® M12-L, unshielded



Male
3 poles, A-coding,
with pre-leading contact
(assignment 3, 4, 5)

21 03 212 1400

3 poles, A-coding
(assignment 1, 3, 4)

21 03 212 1306

4 poles, A-coding
(assignment 1, 2, 3, 4)

21 03 212 1305

4 poles, A-coding,
to 2.6 mm core diameter
(assignment 1, 2, 3, 4)

21 03 212 1407

0.34 - 0.75 mm²
AWG 22 - 18
Cable diameter: 6 - 8 mm

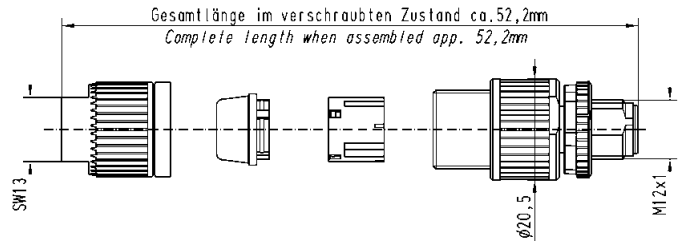

HARAX® M12-L, unshielded



Male
5 poles, A-coding

21 03 272 1505

0.34 - 0.5 mm²
AWG 22 - 20
Cable diameter: 6 - 8 mm

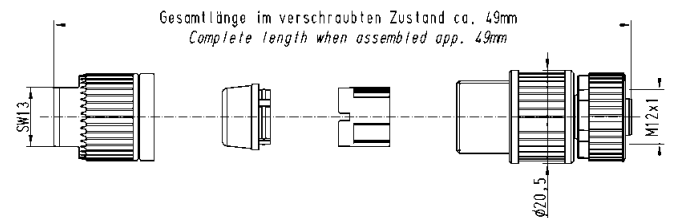



Mating face

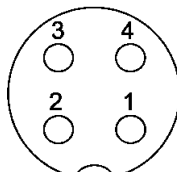

A-coding
Mating face
acc. to IEC 61076-2-101



Identification	Part number	Drawing	Dimensions in mm
----------------	-------------	---------	------------------

HARAX® M12-L, unshielded



Female
3 poles, A-coding
(assignment 3, 4, 5)

21 03 212 2400

3 poles, A-coding
(assignment 1, 3, 4)

21 03 212 2306

4 poles, A-coding
(assignment 1, 2, 3, 4)

21 03 212 2305

4 poles, A-coding,
to 2.6 mm core diameter
(assignment 1, 2, 3, 4)

21 03 212 2407

0.34 - 0.75 mm²
AWG 22 - 18
Cable diameter: 6 - 8 mm

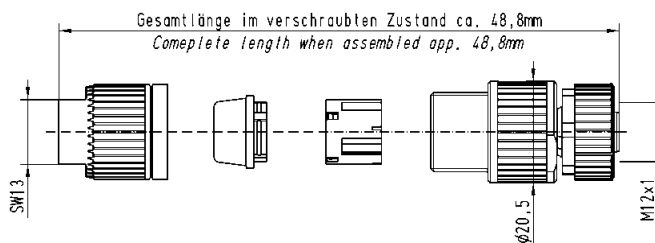

HARAX® M12-L, unshielded



Female
5 poles, A-coding

21 03 272 2505

0.34 - 0.5 mm²
AWG 22 - 20
Cable diameter: 6 - 8 mm

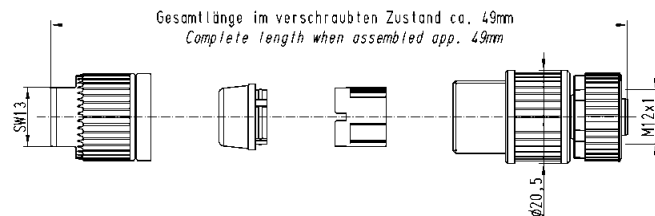



Mating face

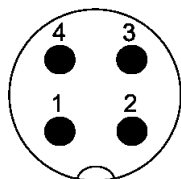

A-coding
Mating face
acc. to IEC 61076-2-101



Identification

Part number

Drawing

Dimensions in mm

HARAX® M12-L, shielded



Male
4 poles, A-coding
0.14 - 0.34 mm² / AWG 26 - 22

21 03 221 1405

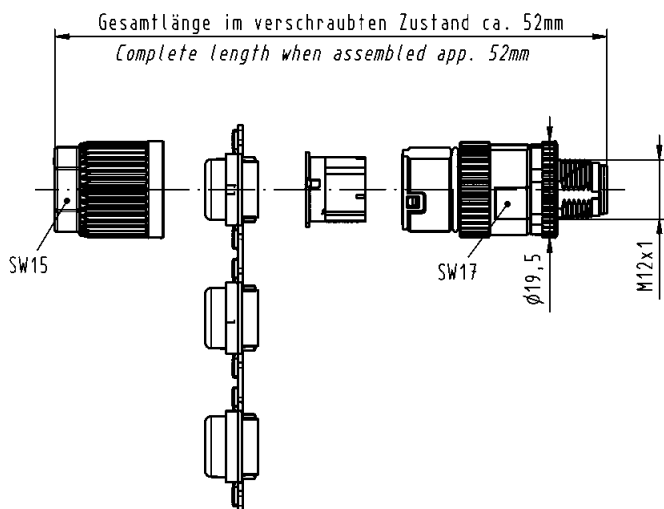

M12 Circular connector



Male
with IDC termination technology,
8 poles
0.14 - 0.34 mm² / AWG 26 - 22

21 03 121 1801

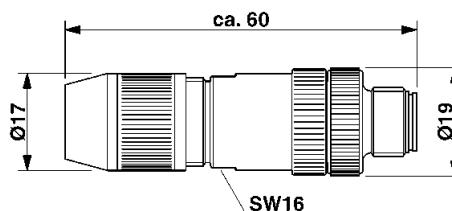



Mating face

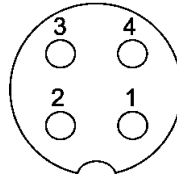

A-coding
Mating face
acc. to IEC 61076-2-101



Identification	Part number	Drawing	Dimensions in mm
----------------	-------------	---------	------------------

HARAX® M12-L, shielded



Female
4 poles, A-coding
0.14 - 0.34 mm² / AWG 26 - 22

21 03 221 2405

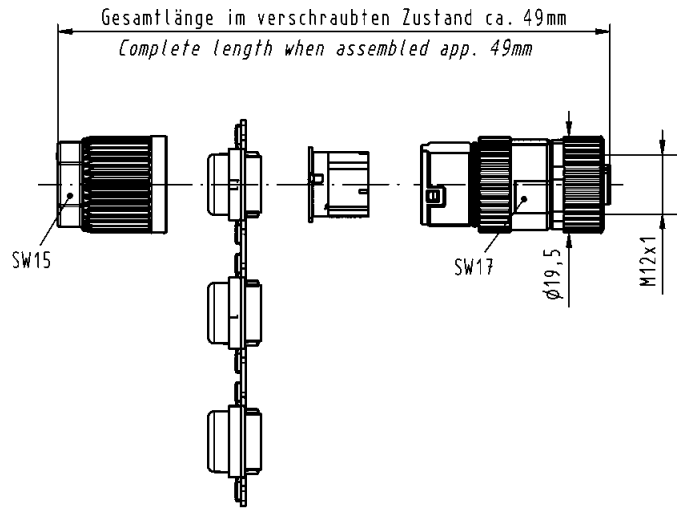

M12 Circular connectors



Female
with IDC termination technology,
8 poles
0.14 - 0.34 mm² / AWG 26 - 22

21 03 121 2801

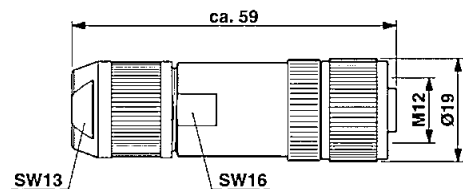

M12 Crimp A-coded



Mating face

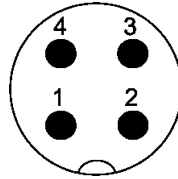

A-coding
Mating face
acc. to IEC 61076-2-101



Identification Part number Drawing Dimensions in mm

M12 Crimp



Male
4 poles, A-coding

21 03 812 1405

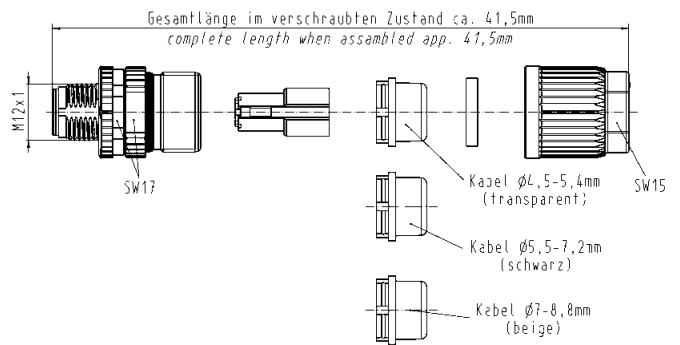

M12 Crimp



Male
5 poles, A-coding

21 03 812 1505*

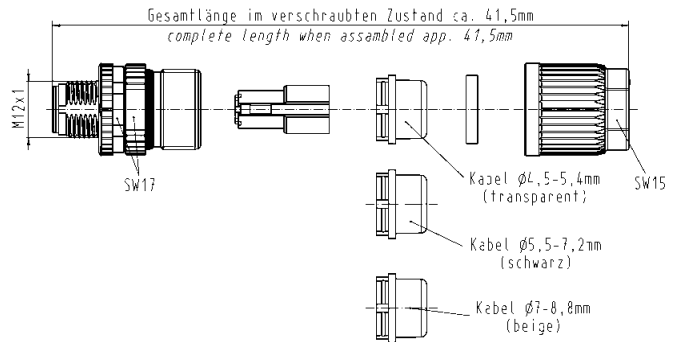

M12 Crimp Slim design



Male
5 poles, A-coding
Cable diameter: 5.7 - 8.8 mm

21 03 821 1505*

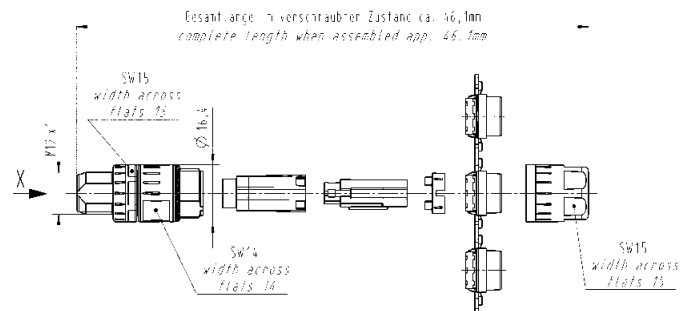

Male
8 poles, A-coding
Cable diameter: 5.7 - 8.8 mm

21 03 821 1805*

M12 Crimp A-coded



Mating face

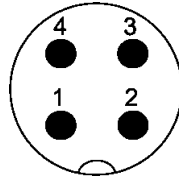

A-coding
Mating face
acc. to IEC 61076-2-101



Circular Connectors

Identification

Part number

Drawing

Dimensions in mm

M12 Crimp, angled



Male
5 poles, A-coding

21 03 822 3505*

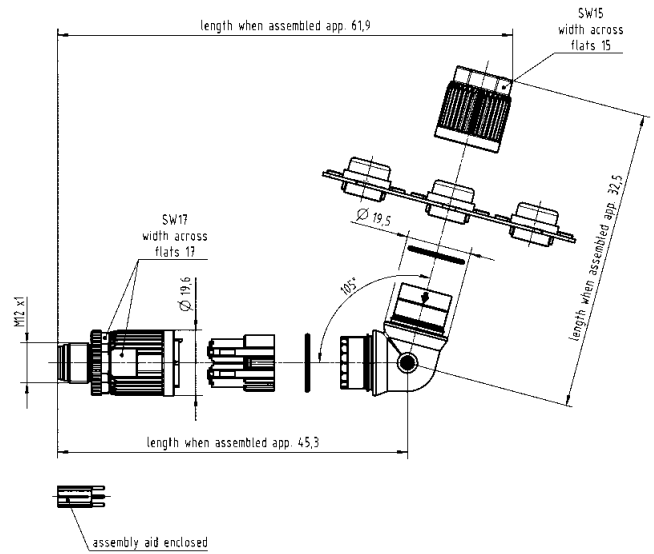



Mating face

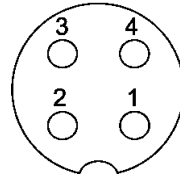

A-coding
Mating face
acc. to IEC 61076-2-101



Identification

Part number

Drawing

Dimensions in mm

M12 Crimp



Female
4 poles, A-coding

21 03 812 2405

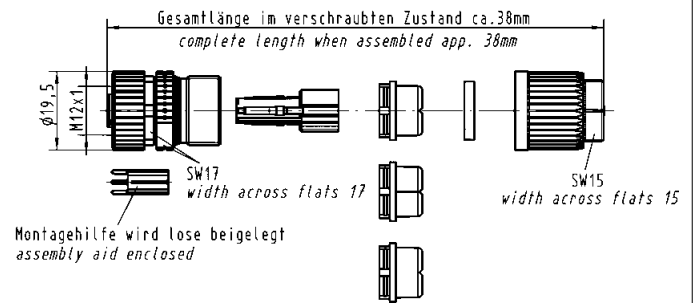

M12 Crimp



Female
5 poles, A-coding

21 03 812 2505*

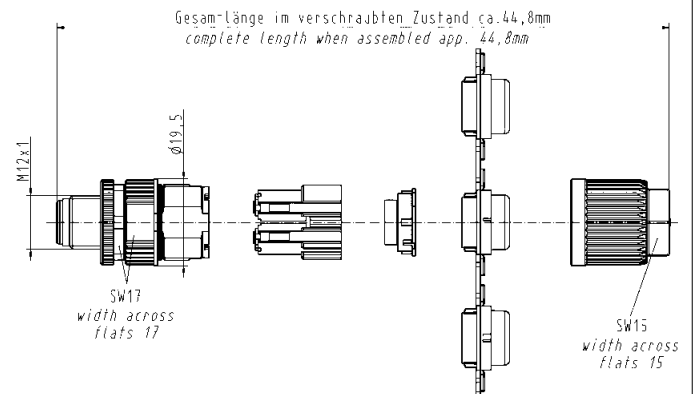



Mating face

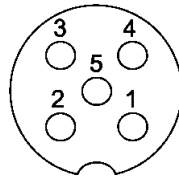

A-coding
Mating face
acc. to IEC 61076-2-101



Identification

Part number

Drawing

Dimensions in mm

M12 Crimp, angled



Female
5 poles, A-coding

21 03 822 4505*

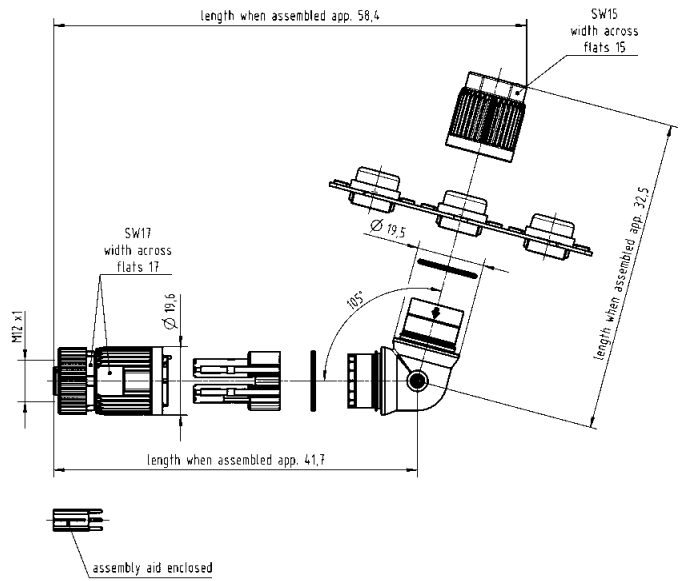



Male, 3 poles

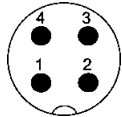

Male, 4 poles

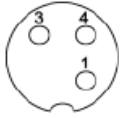

Female, 3 poles

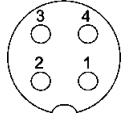

Female, 4 poles



Technical characteristics

System cables with M12 circular connectors without PE, A-coding

	3 poles		4 poles	
	PVC	PUR	PVC	PUR
Rated voltage	max. 250 V AC/DC	max. 250 V AC/DC	max. 250 V AC/DC	max. 250 V AC/DC
Rated current / contact	max. 4 A at +40 °C	max. 4 A at +40 °C	max. 4 A at +40 °C	max. 4 A at +40 °C
Screw locking	M12x1, self securing	M12x1, self securing	M12x1, self securing	M12x1, self securing
Recommended torque	0.6 Nm	0.6 Nm	0.6 Nm	0.6 Nm
Temperature range (working and storage)	-30 °C ... +80 °C	-30 °C ... +80 °C	-30 °C ... +80 °C	-30 °C ... +80 °C
Degree of protection	IP67	IP67	IP67	IP67
Number of wires / wire gauge	3 x 0.34 mm ²	3 x 0.34 mm ²	4 x 0.34 mm ²	4 x 0.34 mm ²
Conductor insulation	PVC (bn, bu, bk)	PP (bn, bu, bk)	PVC (bn, wh, bu, bk)	PP (bn, wh, bu, bk)
Arrangement of insulated strands	42 x Ø 0.1 mm	42 x Ø 0.1 mm	42 x Ø 0.1 mm	42 x Ø 0.1 mm
Sheath	PVC	PUR (UL, CSA)	PVC	PUR (UL, CSA)
Sheath colour	grey	black	grey	black
Outer diameter	Ø 4.4 ± 0.15 mm	Ø 4.4 ± 0.15 mm	Ø 4.7 ± 0.15 mm	Ø 4.7 ± 0.15 mm
Useable as trailing cable	no	yes	no	yes
Halogen free acc. to	–	DIN VDE 0472 part 815	–	DIN VDE 0472 part 815
Flame retardant acc. to	DIN EN 60332-2-2	cUL20549	DIN EN 60332-2-2	cUL20549
Oil-resistant	–	–	–	DIN EN 60811-2-1

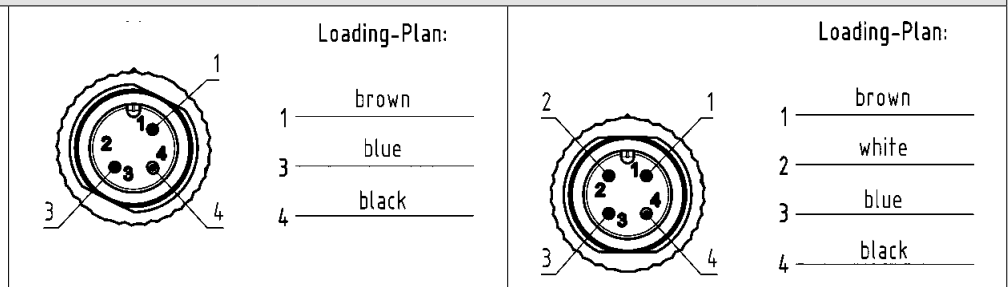

M12 System cables, A-coding, 3 and 4 poles



Male, 3 poles

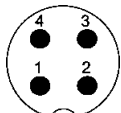

Male, 4 poles



Female, 3 poles

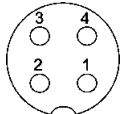

Female, 4 poles



Circular Connectors

Part number definition



Connector 1

- 84 Male straight
- 85 Female straight
- 86 Male angled
- 87 Female angled

Connector 2

- 00 No connector
- 84 Male straight
- 85 Female straight
- 86 Male angled
- 87 Female angled

Number of contacts

- 3 3 poles
- 4 4 poles

Cable material

- 83 PVC (3 poles)
- 84 PVC (4 poles)
- 90 PUR (3 poles)
- 91 PUR (4 poles)

Preferred length*

- 005 0.5 m
- 010 1.0 m
- 015 1.5 m
- 020 2.0 m
- 050 5.0 m
- 075 7.5 m
- 100 10.0 m

* Other length on request

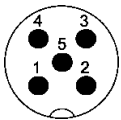

Male, 5 poles

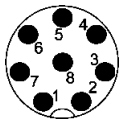

Male, 8 poles

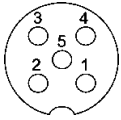

Female, 5 poles

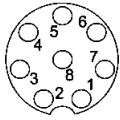

Female, 8 poles



Technical characteristics

System cables with M12 circular connectors without PE, A-coding

	5 poles	8 poles
	PVC	PVC
Rated voltage	max. 60 V AC/DC	max. 30 V AC/DC
Rated current / contact	max. 4 A at +40 °C	max. 2 A at +40 °C
Screw locking	M12x1, self securing	M12x1, self securing
Recommended torque	0.6 Nm	0.6 Nm
Temperature range (working and storage)	-30 °C ... +80 °C	-30 °C ... +80 °C
Degree of protection	IP67	IP67
Number of wires / wire gauge	5 x 0.34 mm ²	8 x 0.25 mm ²
Conductor insulation	PVC (bn, wh, bu, bk, gn/ye)	PVC (wh, bn, gn, ye, gy, pk, bu, rd)
Arrangement of insulated strands	42 x Ø 0.1 mm	32 x Ø 0.1 mm
Sheath	PVC	PVC
Sheath colour	grey	grey
Outer diameter	Ø 5.2 ± 0.15 mm	Ø 6.2 ± 0.2 mm
Useable as trailing cable	no	no
Halogen free acc. to	-	-
Flame retardant acc. to	DIN EN 60332-2-2	DIN EN 60332-2-2
Oil-resistant	-	-

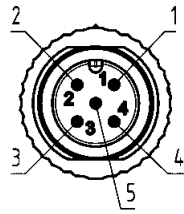

Loading-Plan:

- 1 brown
- 2 white
- 3 blue
- 4 black
- 5 green-yellow

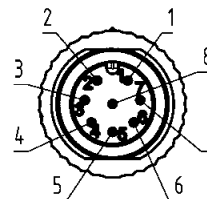

Loading-Plan:

- 1 white
- 2 brown
- 3 green
- 4 yellow
- 5 grey
- 6 pink
- 7 blue
- 8 red

M12 System cables, A-coding, 5 and 8 poles

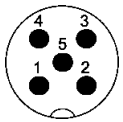

Male, 5 poles

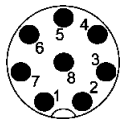

Male, 8 poles

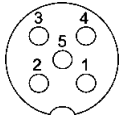

Female, 5 poles

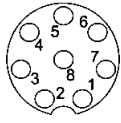

Female, 8 poles



Circular Connectors

Part number definition



- Connector 1**
- 84 Male straight
 - 85 Female straight
 - 86 Male angled
 - 87 Female angled

- Connector 2**
- 00 No connector
 - 84 Male straight
 - 85 Female straight
 - 86 Male angled
 - 87 Female angled

- Number of contacts**
- 5 5 poles
 - 8 8 poles

- Cable material**
- 82 PVC (8 poles)
 - 85 PVC (5 poles)

- Preferred length***
- 005 0.5 m
 - 010 1.0 m
 - 015 1.5 m
 - 020 2.0 m
 - 050 5.0 m
 - 075 7.5 m
 - 100 10.0 m

* Other length on request



Male, 12 poles

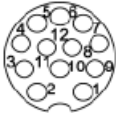

Female, 12 poles



Technical characteristics

System cables with M12 circular connectors without PE, A-coding

	12 poles	
	PVC	PUR
Rated voltage	max. 30 V AC/DC	max. 30 V AC/DC
Rated current / contact	max. 1.5 A at +40 °C	max. 1.5 A at +40 °C
Screw locking	M12x1, self securing	M12x1, self securing
Recommended torque	0.6 Nm	0.6 Nm
Temperature range (working and storage)	-30 °C ... +80 °C	-30 °C ... +80 °C
Degree of protection	IP67	IP67
Number of wires / wire gauge	12 x 0.14 mm ²	12 x 0.14 mm ²
Conductor insulation	PVC (core: vt, rd/bu, gy/pk outer: bn, rd, gy, bk, ye, pk, gn, wh, bu)	PP (core: vt, rd/bu, gy/pk outer: bn, rd, gy, bk, ye, pk, gn, wh, bu)
Arrangement of insulated strands	18 x Ø 0.1 mm	18 x Ø 0.1 mm
Sheath	PVC	PUR (UL, CSA)
Sheath colour	grey	black
Outer diameter	Ø 6.2 ± 0.2 mm	Ø 6.1 ± 0.2 mm
Useable as trailing cable	no	yes
Halogen free acc. to	–	DIN VDE 0472 part 815
Flame retardant acc. to	DIN EN 60332-1-2	cUL20549
Oil-resistant	DIN EN 60811-2-1	–

Loading-Plan:

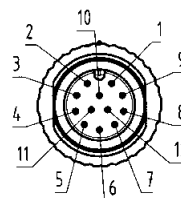

- 1 brown
- 2 blue
- 3 white
- 4 green
- 5 pink
- 6 yellow
- 7 black
- 8 grey
- 9 red
- 10 violet
- 11 grey-pink
- 12 red-blue

M12 System cables, A-coding, 12 poles



Male, 12 poles

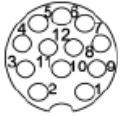

Female, 12 poles



Part number definition



Connector 1

- 84 Male straight
- 85 Female straight
- 86 Male angled
- 87 Female angled

Connector 2

- 00 No connector
- 84 Male straight
- 85 Female straight
- 86 Male angled
- 87 Female angled

Number of contacts

C 12 poles

Cable material

- 78 PUR
- 79 PVC

Preferred length*

- 005 0.5 m
- 010 1.0 m
- 015 1.5 m
- 020 2.0 m
- 050 5.0 m
- 075 7.5 m
- 100 10.0 m

* Other length on request

Mating face

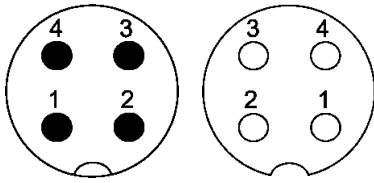

A-coding
Mating face
acc. to IEC 61076-2-101



Identification

Part number

Drawing

Dimensions in mm

M12 Circular connectors

Female angled, with LED,
Male straight

Length: 0.3 m
0.6 m
1.0 m
1.5 m
2.0 m

21 03 415 7401
21 03 415 7402
21 03 415 7403
21 03 415 7404
21 03 415 7405

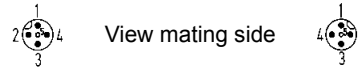
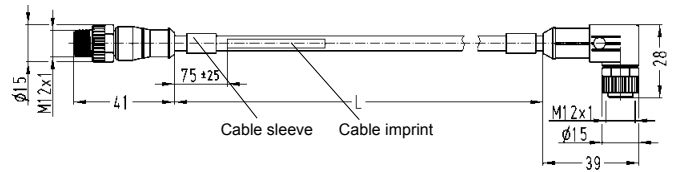

Schematic diagram

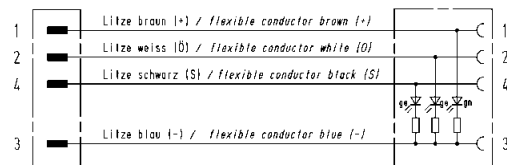

Mating face

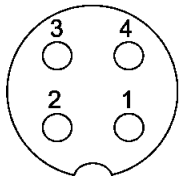

A-coding
Mating face
acc. to IEC 61076-2-101



Identification	Part number	Drawing	Dimensions in mm
----------------	-------------	---------	------------------

M12 Circular connectors
Female angled, with LED
pre-assembled on one end

Length:	1.5 m	21 03 515 7401
	3.0 m	21 03 515 7402
	5.0 m	21 03 515 7403
	7.5 m	21 03 515 7404
	10.0 m	21 03 515 7405

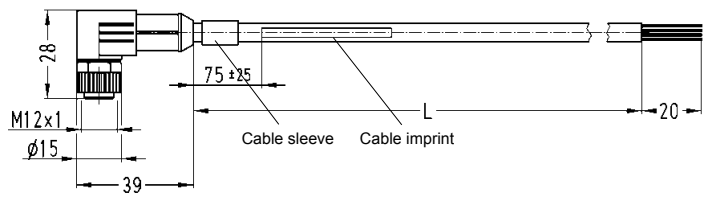

Schematic diagram

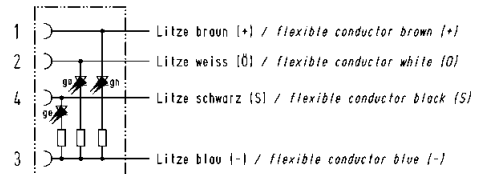

View mating side





Mating face

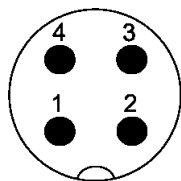

A-coding
Mating face
acc. to IEC 61076-2-101



Applications / Advantages

- Actor and sensor applications
- For panel feed-through or PCB, straight version in IP20 or IP67, with or without assembled pigtail
- Available with crimp resp. HARAX® rapid termination
- Quick and easy assembly

Identification	Part number	Drawing	Dimensions in mm
<p>HARAX® Panel feed-through</p>  <p>Male 4 poles, A-coding 0.14 - 0.34 mm² / AWG 26 - 22</p> <p>Panel thickness min. 2.5 mm max. 4.5 mm</p>	<p>21 03 321 1425</p>	<p>Gesamtlänge im verschraubten Zustand ca. 51,5mm complete length when assembled app. 51,5mm</p> <p>18,4</p> <p>M12x1 M16x1,5 M16x1</p> <p>SW17 width across flats 17</p> <p>SW13 width across flats 13</p> <p>Kabel/cable ϕ4,5-5,4mm (transparent/transparent)</p> <p>Kabel/cable ϕ5,5-7,2mm (schwarz/black)</p> <p>Kabel/cable ϕ7-8,8mm (beige/beige)</p> <p>SW20</p> <p>ϕ16,3 \pm0,2</p> <p>15,4 \pm0,2</p>	

M12 Panel feed-through HARAX® A-coded



Mating face

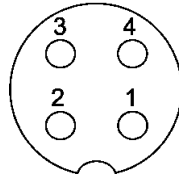

A-coding
Mating face
acc. to IEC 61076-2-101



Circular
Connectors

Identification

Part number

Drawing

Dimensions in mm

HARAX® Panel feed-through



21 03 321 2425

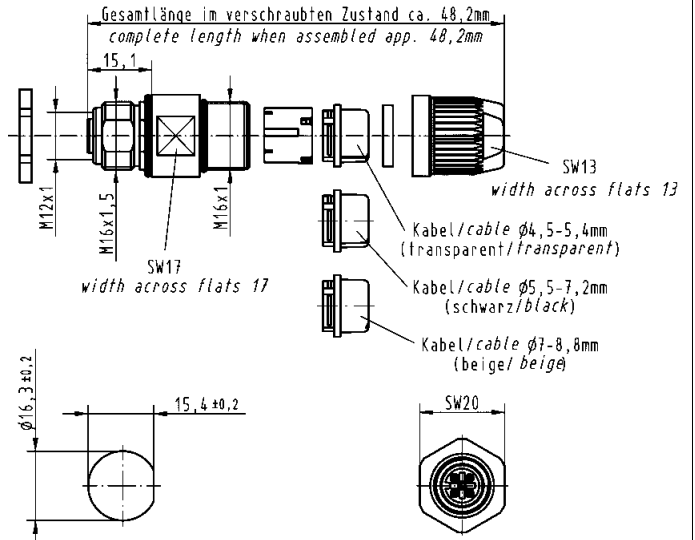

Female
4 poles, A-coding
0.14 - 0.34 mm² / AWG 26 - 22

Panel thickness
min. 2.5 mm
max. 4.5 mm

M12 Panel feed-through Crimp A-coded



Mating face

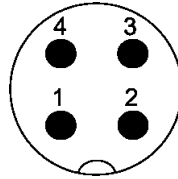

A-coding
Mating face
acc. to IEC 61076-2-101



Identification Part number Drawing Dimensions in mm

M12 Panel feed-through Crimp



Male
4 poles, A-coding

Panel thickness
min. 2.5 mm
max. 4.5 mm

21 03 822 1425

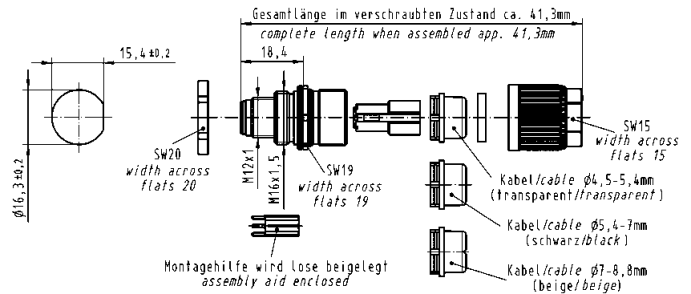

M12 Panel feed-through Crimp



Male
5 poles, A-coding

Panel thickness
min. 2.5 mm
max. 4.5 mm

21 03 822 1525*

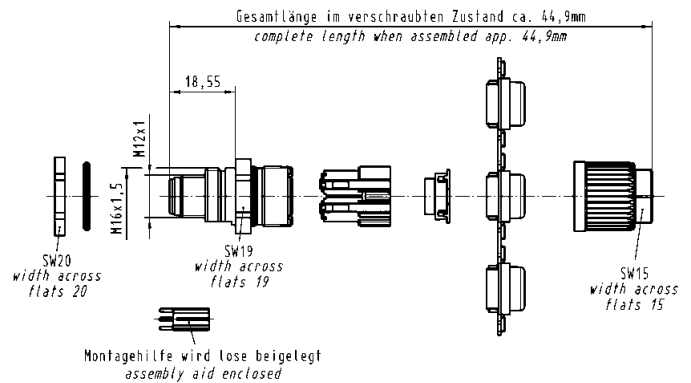

M12 Panel feed-through Crimp A-coded



Mating face

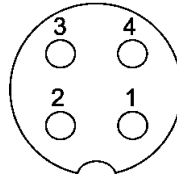

A-coding
Mating face
acc. to IEC 61076-2-101



Circular Connectors

Identification Part number Drawing Dimensions in mm

M12 Panel feed-through Crimp



Female
4 poles, A-coding

Panel thickness
min. 2.5 mm
max. 4.5 mm

21 03 822 2425

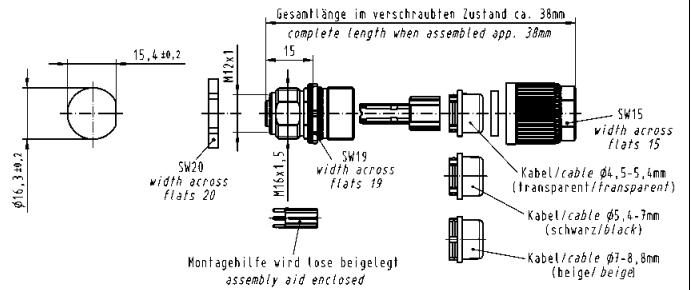

M12 Panel feed-through Crimp



Female
5 poles, A-coding

Panel thickness
min. 2.5 mm
max. 4.5 mm

21 03 822 2525*

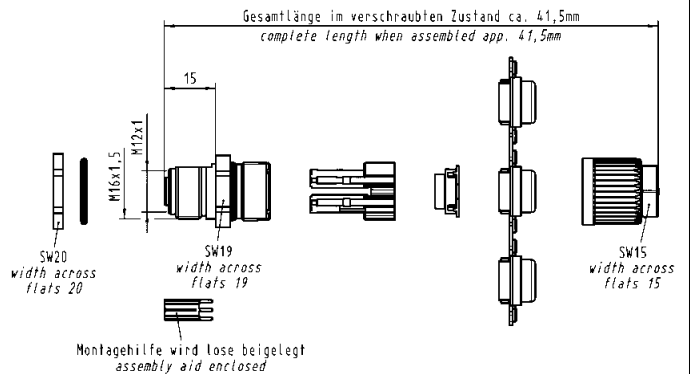

M12 Panel feed-through A-coded



Circular Connectors



Mating face

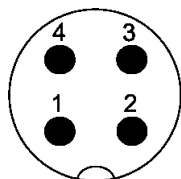

A-coding
Mating face
acc. to IEC 61076-2-101



Identification	Part number	Drawing	Dimensions in mm
----------------	-------------	---------	------------------

M12 Panel feed-through



Male
A-coding,
50 cm conductors, 0.5 mm², 4 poles

Panel thickness
min. 2.0 mm
max. 5.0 mm

Panel thickness
min. 1.0 mm
max. 4.0 mm

21 03 311 1402

21 03 371 1405

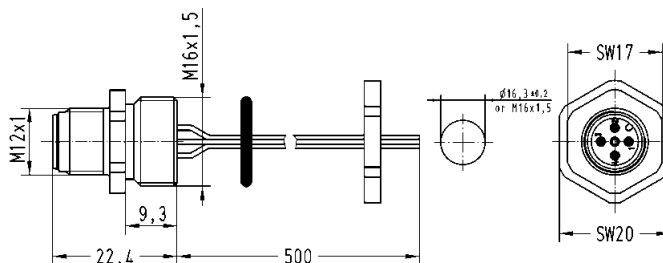

M12 Panel feed-through



Male
A-coding,
50 cm conductors, 0.5 mm², 5 poles

Panel thickness
min. 2.0 mm
max. 5.0 mm

21 03 311 1501

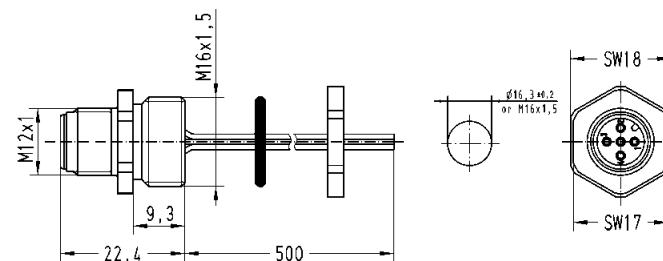

M12 Panel feed-through A-coded



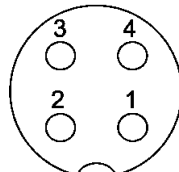

Mating face



A-coding
Mating face
acc. to IEC 61076-2-101



Circular Connectors

Identification	Part number	Drawing	Dimensions in mm
<p>M12 Panel feed-through</p>  <p>Female A-coding, 50 cm conductors, 0.5 mm², 4 poles</p> <p>Panel thickness min. 2.0 mm max. 5.0 mm</p>	<p>21 03 311 2400</p>		
<p>M12 Panel feed-through</p>  <p>Female A-coding, 50 cm conductors, 0.5 mm², 5 poles</p> <p>Panel thickness min. 2.0 mm max. 5.0 mm</p>	<p>21 03 311 2501</p>		



Mating face

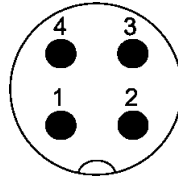



A-coding
Mating face
acc. to IEC 61076-2-101

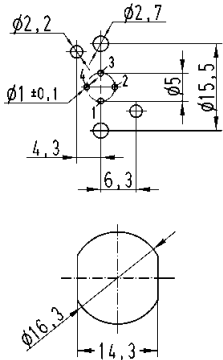
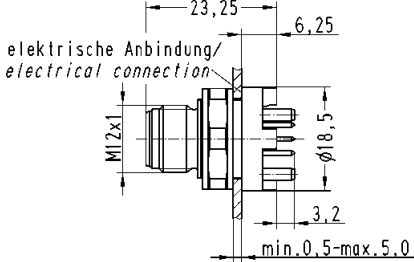

Technical characteristics: M12 PCB adapter

Degree of protection	IP20, IP67 (mated and locked)	Temperature during connection	-5 °C ... +50 °C
Rated current	max. 4 A (dependant on PCB layout)	Termination	PIH
Rated voltage	4 poles: 250 V 5 poles: 50 V	Contact material	Copper alloy
Mating cycles	max. 100	Contact plating (mating side)	Au over Ni
Limiting temperature	-40 °C ... +85 °C	Insulator material	PA

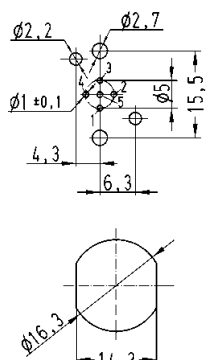
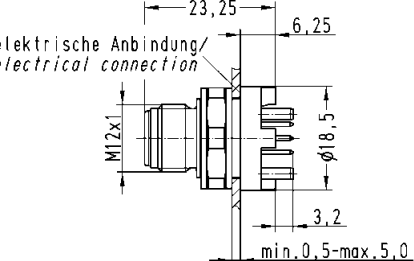
Identification	Part number	Drawing	Dimensions in mm
M12 PCB adapter Male, A-coding, straight 	4 poles, IP20 4 poles, IP67		
M12 PCB adapter Male, A-coding, straight 	5 poles, IP20 5 poles, IP67		

M12 PCB adapter A-coded



Mating face

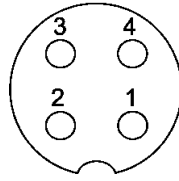

A-coding
Mating face
acc. to IEC 61076-2-101



Circular Connectors

Identification	Part number	Drawing	Dimensions in mm
----------------	-------------	---------	------------------

M12 PCB adapter

Female, A-coding, straight



4 poles, IP20
4 poles, IP67

21 03 321 6410
21 03 321 6420*

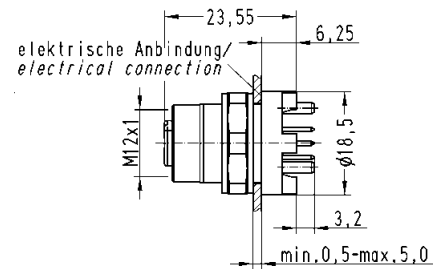
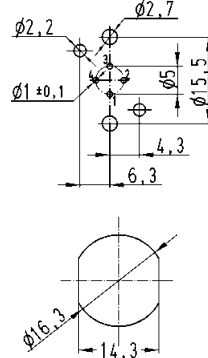

M12 PCB adapter

Female, A-coding, straight



5 poles, IP20
5 poles, IP67

21 03 321 6510
21 03 321 6520

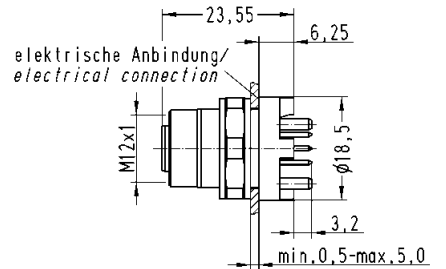
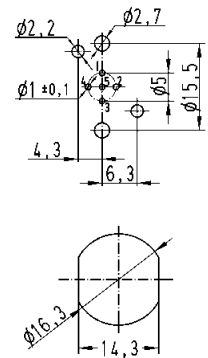

M12 PCB adapter shielded A-coded



Mating face

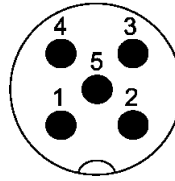

A-coding
Mating face
acc. to IEC 61076-2-101



Identification	Part number	Drawing	Dimensions in mm
----------------	-------------	---------	------------------

M12 PCB adapter, shielded

Packaging: 60 pieces in a tray
Order housing separately

- Male
- 4 poles, A-coding
 - 5 poles, A-coding
 - 8 poles, A-coding

Packaging: 1 piece incl. housing

- Male
- 5 poles, A-coding, rear mounting
 - 8 poles, A-coding, rear mounting
 - 5 poles, A-coding, front mounting
 - 8 poles, A-coding, front mounting

- 21 03 321 1418*
- 21 03 321 1518*
- 21 03 321 1818*

- 21 03 321 1530*
- 21 03 321 1830*
- 21 03 321 1531*
- 21 03 321 1831

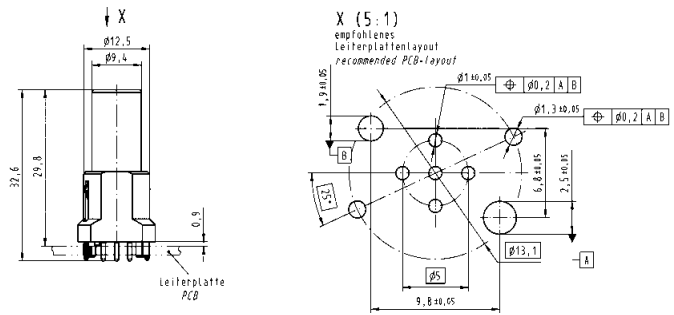

Housing



Packaging: 10 pieces in a tube

- for rear mounting
- for front mounting

- 21 03 301 1000
- 21 03 301 1001

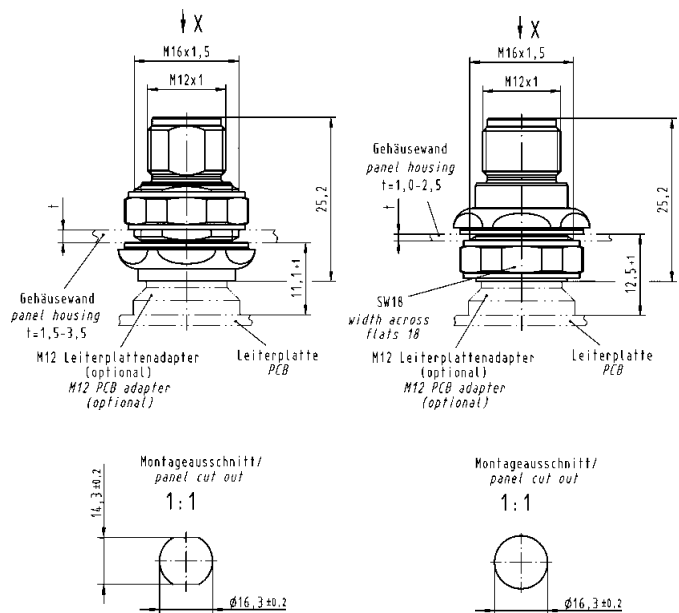

M12 PCB adapter shielded A-coded



Mating face

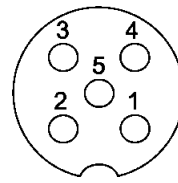

A-coding
Mating face
acc. to IEC 61076-2-101



Circular Connectors

Identification	Part number	Drawing	Dimensions in mm
<p>M12 PCB adapter, shielded</p> <p>Packaging: 60 pieces in a tray Order housing separately</p> <p>Female 4 poles, A-coding 5 poles, A-coding 8 poles, A-coding</p> <p>Packaging: 1 piece incl. housing</p> <p>Female 5 poles, A-coding, rear mounting 8 poles, A-coding, rear mounting 5 poles, A-coding, front mounting 8 poles, A-coding, front mounting</p>	<p>21 03 321 2418*</p> <p>21 03 321 2518*</p> <p>21 03 321 2818*</p> <p>21 03 321 2530*</p> <p>21 03 321 2830*</p> <p>21 03 321 2531*</p> <p>21 03 321 2831</p>		
<p>Housing</p> <p>Packaging: 10 pieces in a tube</p> <p>for rear mounting</p> <p>for front mounting</p>	<p>21 03 301 2000</p> <p>21 03 301 2003</p>		<p>Montageausschnitt/ panel cut out 1:1</p> <p>Montageausschnitt/ panel cut out 1:1</p>

Further information and data sheets see www.HARTING.com
* UL approval is in preparation

Identification

Part number

Drawing

M12-male moving load

A-coding



21 03 030 1400

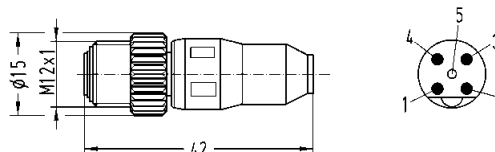

HARTING M12 T-Coupler

Profibus

21 03 321 9400

A-coding

21 03 319 9501



Crimping tool for M12 Crimp

09 99 000 0501



Accessories M12 Crimp

Locator

for D-Sub contacts

09 99 000 0531

for contact 21 01 100 9020

61 03 600 0023



D-Sub single contacts (500 mating cycles)

turned male contacts

AWG 22 - 18 / 0.33 - 0.82 mm²

09 67 000 3576

AWG 24 - 20 / 0.25 - 0.52 mm²

09 67 000 8576

AWG 26 - 22 / 0.13 - 0.33 mm²

09 67 000 5576

AWG 28 - 24 / 0.09 - 0.25 mm²

09 67 000 7576



turned female contacts

AWG 22 - 18 / 0.33 - 0.82 mm²

09 67 000 3476

AWG 24 - 20 / 0.25 - 0.52 mm²

09 67 000 8476

AWG 26 - 22 / 0.13 - 0.33 mm²

09 67 000 5476

AWG 28 - 24 / 0.09 - 0.25 mm²

09 67 000 7476



turned male contact for 8 pole connectors, A-coding, AWG 26 - 22

21 01 100 9020

D-Sub contacts

Part number	AWG	Tool settings
09 67 000 3x76	18	6
	20	6
	22	5
09 67 000 8x76	20, 22, 24	6
09 67 000 5x76	22, 24, 26	6

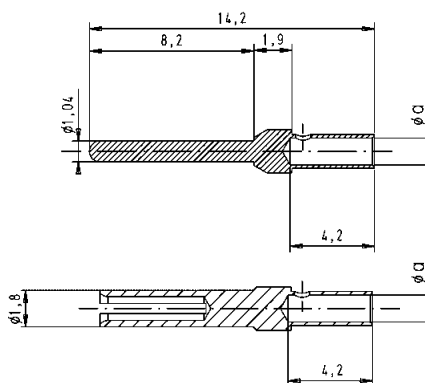

	a
AWG 22 - 18	1.34
AWG 24 - 20	1.13
AWG 26 - 22	0.88

M12 dynamometric screwdriver

Tightening torque 0.6 Nm

for M12-S

SW 13

09 99 000 0382

for M12 Slim design

SW 15









09 99 000 0646



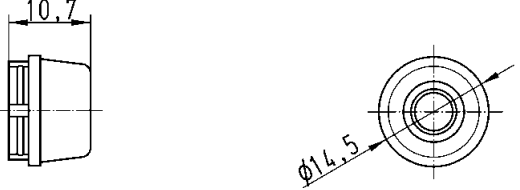

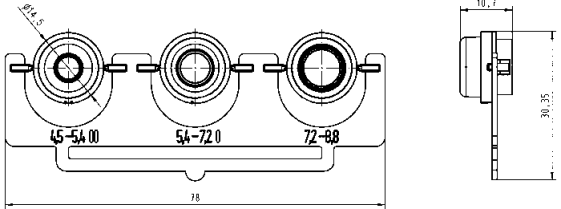

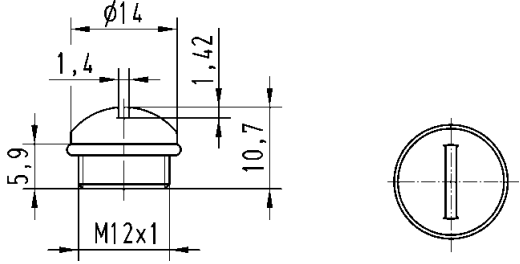
for M12-L

SW 17

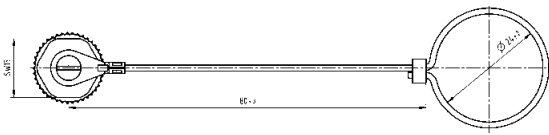
09 99 000 0384

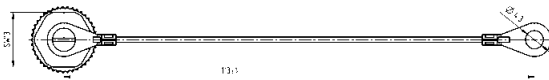

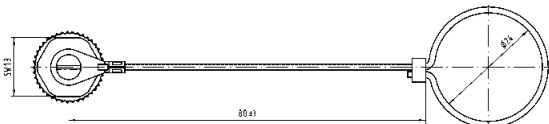
Identification	Part number	Drawing	Dimensions in mm
<p>Seal M12-S for 2.9 - 4.0 mm cable Ø for 4 - 5.1 mm cable Ø</p> 	<p>21 01 010 2011 21 01 010 2001</p>		
<p>Seal M12-L unshielded for 4.7 - 6 mm cable Ø for 6 - 8 mm cable Ø</p> 	<p>21 01 010 2015 21 01 010 2007</p>		
<p>Set of seals M12-L shielded for 4.5 - 5.4 mm cable Ø for 5.4 - 7.2 mm cable Ø for 7.2 - 8.8 mm cable Ø</p> 	<p>21 01 010 2017</p>		
<p>Cap M12 for IP65 / 67 Seals material Viton Plastic cap for female</p> 	<p>21 01 000 0003</p>		
<p>Accessories M12</p> <p>Lock nut</p>	<p>21 01 000 0018</p>		

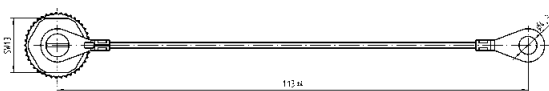
Identification	Part number	Drawing	Dimensions in mm
<p>Cap metal M12 for IP65 / 67 M12 metal cap for male side with cord</p> 	<p>21 01 000 0033</p>		
<p>Cap metal M12 for IP65 / 67 M12 metal cap for male side with cable clip</p> 	<p>21 01 000 0038</p>		
<p>Cap metal M12 for IP65 / 67 M12 metal cap for female side with cord</p> 	<p>21 01 000 0030</p>		
<p>Cap metal M12 for IP65 / 67 M12 metal cap for female side with cable clip</p> 	<p>21 01 000 0031</p>		

Specifications IEC 60352-4

Approval

Mating face

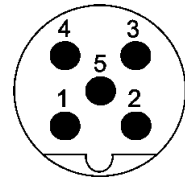

B-coding
Mating face
acc. to IEC 61076-2-101



Technical characteristics M12 – B-coding

Type M12 B-coded	HARAX® M12 L shielded	M12 Crimp
------------------	-----------------------	-----------

General data

Conductor cross section	0.25 - 0.34 mm ² AWG 24-22	0.13 - 0.75 mm ² AWG 26-18
Diameter of individual strands	≥ 0.1 mm	X
Conductor insulation material	PVC, Zell-PE	X
Conductor diameter	2 - 2.6 mm	2.0 - 2.3 mm
Cable diameter	7.0 - 8.8 mm	4 poles: 4.5 - 8.8 mm 5 poles: 4.5 - 8.8 mm
Temperature range	-40 °C ... +85 °C	-40 °C ... +85 °C
Temperature during connection	-5 °C ... +50 °C	-5 °C ... +50 °C
Degree of protection	IP65 / 67	IP67
Mating cycles	100	500
Tightening torque connector / hexagonal wrench	0.6 Nm / SW 17	0.5 Nm / SW 17

Electrical characteristics

Rated current	4 A	4 A
Rated voltage	32 V	250 V
Rated impulse voltage	1.5 kV	1.5 kV
Contact resistance	10 mΩ	10 mΩ
Insulation resistance	10 ⁸ Ω	10 ⁸ Ω
Pollution degree	3	3
Overvoltage category	3	3
Isolation group	1	1

Materials

Contact material	Brass	Brass
Contact plating	Gold	Gold
Contact carrier material	PA unreinforced	PA
Housing material	PA unreinforced	PA

Technical characteristics M12 – B-coding

Current carrying capacity The current carrying capacity is limited by maximum temperature of materials for inserts and contacts including terminals. The current capacity-curve is valid for continuous, not interruptet current-loaded contacts of connectors when simultaneous power on all contacts is given, without exceeding the maximum temperature.

Control and test procedures according to DIN IEC 60512-5.

M12-L
3 poles, 4 poles

1 = Wire gauge 0.34 mm²
2 = Wire gauge 0.75 mm²

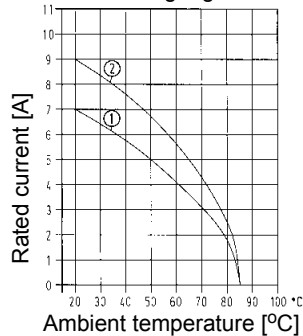

M12, Crimp 1 = Wire gauge 0.34 mm² / 0.5 mm²

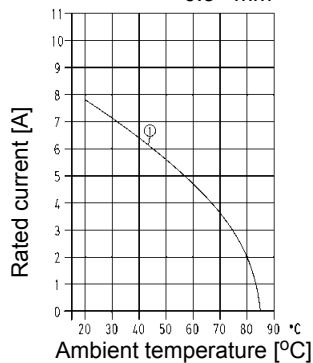



Mating face

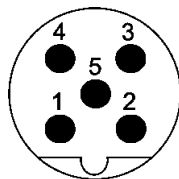

B-coding
Mating face
acc. to IEC 61076-2-101



Applications / Advantages

- B-coding for field bus systems e.g. Profibus, DeviceNet or CANopen
- Available with crimp resp. HARAX® rapid termination, or as overmoulded system cable in various lengths
- Shielding by the hood
- Easy handling, quick assembly

Identification	Part number	Drawing	Dimensions in mm
----------------	-------------	---------	------------------

HARAX® M12-L, shielded



Male
2 poles, B-coding
0.25 - 0.34 mm² / AWG 24 - 22

21 03 241 1301

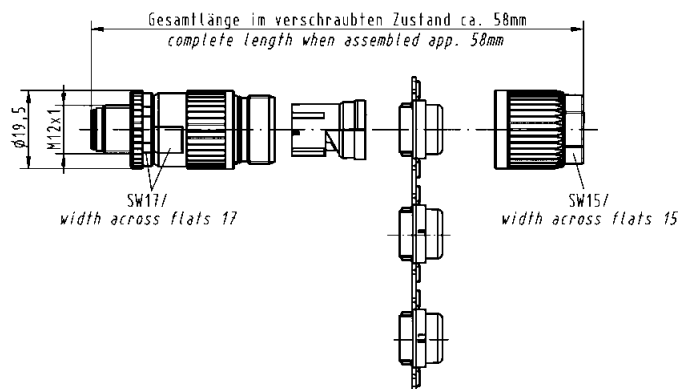



Mating face

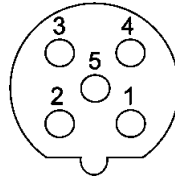

B-coding
Mating face
acc. to IEC 61076-2-101



Identification

Part number

Drawing

Dimensions in mm

HARAX® M12-L, shielded



21 03 241 2301

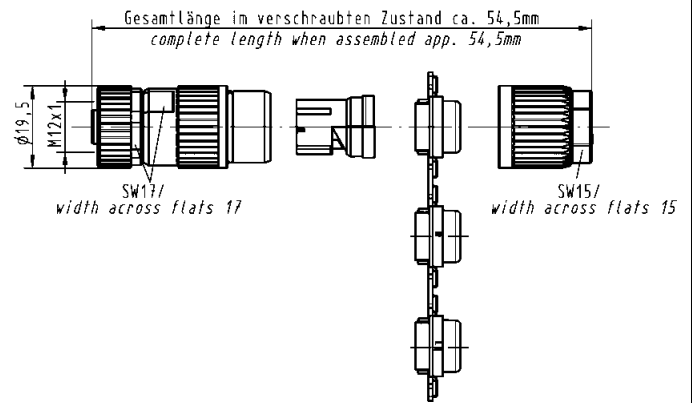

Female
2 poles, B-coding
0.25 - 0.34 mm² / AWG 24 - 22



Mating face

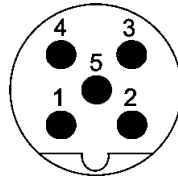

B-coding
Mating face
acc. to IEC 61076-2-101



Identification	Part number	Drawing	Dimensions in mm
----------------	-------------	---------	------------------

M12 Crimp



Male
5 poles, B-coding

21 03 841 1505

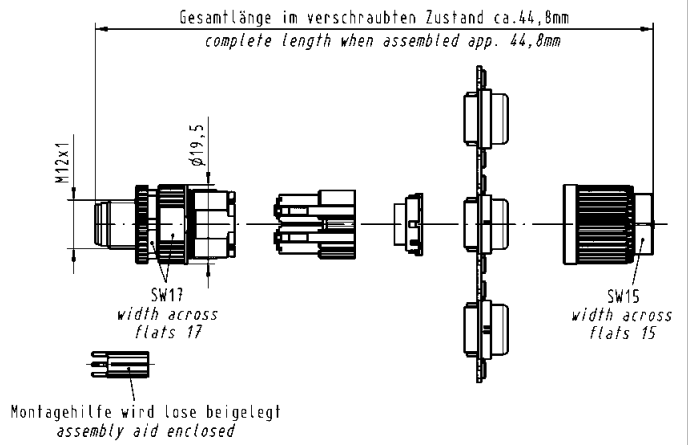

M12 Crimp B-coded



Mating face

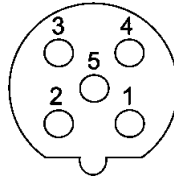

B-coding
Mating face
acc. to IEC 61076-2-101



Circular
Connectors

Identification

Part number

Drawing

Dimensions in mm

M12 Crimp



Female
5 poles, B-coding

21 03 841 2505

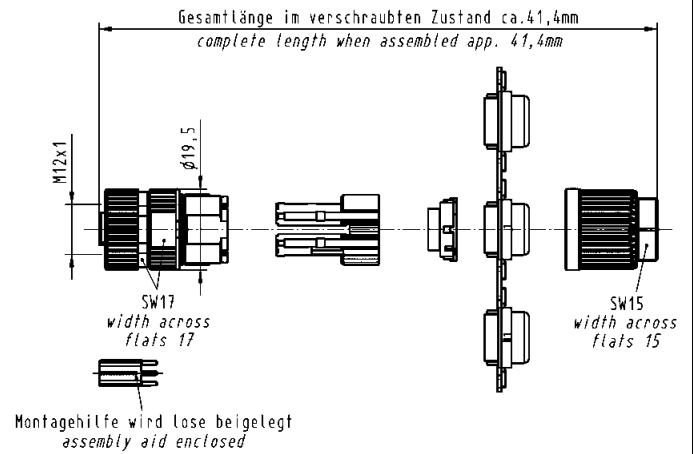



Male, 4 poles

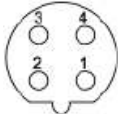

Female, 4 poles



Technical characteristics

System cables with M12 circular connectors shielded, B-coding

	4-poles	
	PVC	PUR
Rated voltage	max. 160 V AC/DC	max. 160 V AC/DC
Rated current / contact	max. 4 A at +40 °C	max. 4 A at +40 °C
Screw locking	M12x1, self securing	M12x1, self securing
Recommended torque	0.6 Nm	0.6 Nm
Temperature range (working and storage)	-30 °C ... +80 °C	-30 °C ... +80 °C
Degree of protection	IP67	IP67
Number of wires / wire gauge	2 x AWG 22	2 x AWG 24
Conductor insulation	PVC (rd, gn)	PE (rd, gn)
Arrangement of insulated strands	1 x Ø 0.65 mm	19 x Ø 0.14 mm
Sheath	PVC	PUR (UL, CSA)
Sheath colour	violet	violet
Outer diameter	Ø 8.0 ± 0.4 mm	Ø 8.5 ± 0.4 mm
Useable as trailing cable	no	yes
Halogen free acc. to	–	DIN VDE 0472 part 815
Flame retardant acc. to	DIN EN 60332-1-2	DIN EN 60332-1-2
Oil-resistant	IEC 80811-2-1 (4h/60°C)	DIN EN 60811-2-1

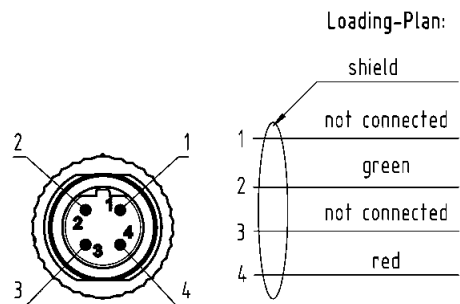



Male, 4 poles

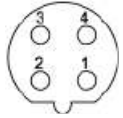

Female, 4 poles



Part number definition



Connector 1

- 88 Male straight
- 89 Female straight
- 90 Male angled
- 91 Female angled

Connector 2

- 00 No connector
- 88 Male straight
- 89 Female straight
- 90 Male angled
- 91 Female angled

Number of contacts
4 4 poles

Cable material

- 86 PVC
- 87 PUR

Preferred length*

- 005 0.5 m
- 010 1.0 m
- 015 1.5 m
- 020 2.0 m
- 050 5.0 m
- 075 7.5 m
- 100 10.0 m

* Other length on request



Mating face

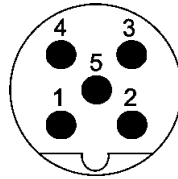

B-coding
Mating face
acc. to IEC 61076-2-101



Applications / Advantages

- B-coding for field bus systems e.g. Profibus, DeviceNet or CANopen
- For panel feed-through or PCB, straight version in IP20 or IP67, with or without assembled pigtail
- Available with crimp resp. HARAX® rapid termination
- Quick and easy assembly

Identification	Part number	Drawing	Dimensions in mm
<p>HARAX® Panel feed-through</p>  <p>Male 2 poles and shielding, B-coding 0.25 - 0.34 mm² / AWG 24 - 22</p> <p>Cable diameter: 7 - 8.8 mm</p> <p>Panel thickness min. 2.5 mm max. 4.5 mm</p>	<p>21 03 341 1425</p>	<p>Technical drawing showing dimensions and part numbers: - Overall length in screwed state: ca. 57mm (complete length when assembled approx. 57mm) - Length of main body: 18.4 - Length of pigtail: 15.4 ± 0.2 - Panel thickness: 2.5 to 4.5 - Part numbers: M12x1.5, M16x1.5, SW17 (width across flats 17), SW13 (width across flats 13), P16x1.1, Ø 6.3 ± 0.2</p>	<p>Dimensions in mm</p>

M12 Panel feed-through HARAX® B-coded



Mating face

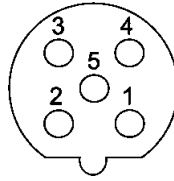

B-coding
Mating face
acc. to IEC 61076-2-101



Circular
Connectors

Identification

Part number

Drawing

Dimensions in mm

HARAX® Panel feed-through



21 03 341 2425

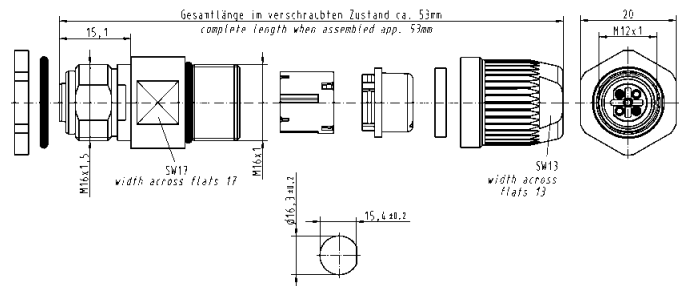

Female
2 poles and shielding, B-coding
0.25 - 0.34 mm² / AWG 24 - 22

Cable diameter: 7 - 8.8 mm

Panel thickness
min. 2.5 mm
max. 4.5 mm

M12 Panel feed-through Crimp B-coded



Circular Connectors



Mating face

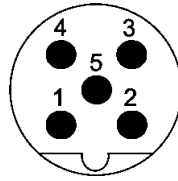

B-coding
Mating face
acc. to IEC 61076-2-101



Identification	Part number	Drawing	Dimensions in mm
----------------	-------------	---------	------------------

M12 Panel feed-through Crimp



Male
5 poles, B-coding

Panel thickness
min. 2.5 mm
max. 4.5 mm

21 03 841 1525

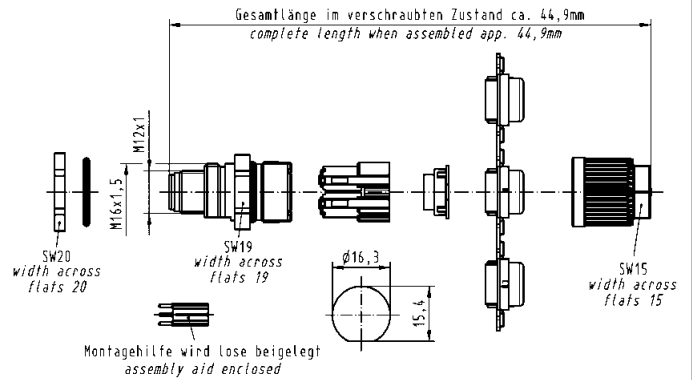

M12 Panel feed-through Crimp B-coded



Mating face

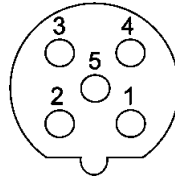

B-coding
Mating face
acc. to IEC 61076-2-101



Circular
Connectors

Identification

Part number

Drawing

Dimensions in mm

M12 Panel feed-through Crimp



Female
5 poles, B-coding

Panel thickness
min. 2.5 mm
max. 4.5 mm

21 03 841 2525

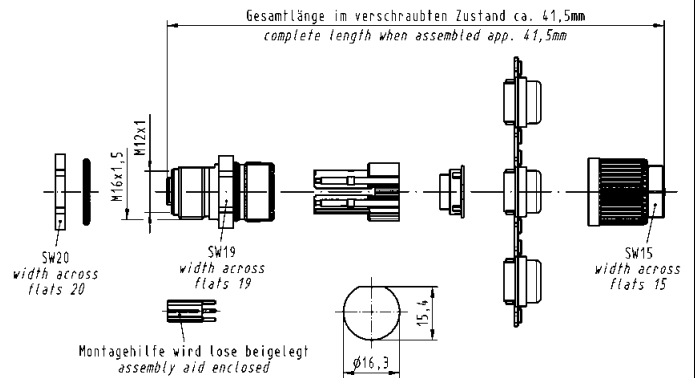

M12 Panel feed-through B-coded



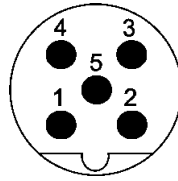

Mating face



B-coding
Mating face
acc. to IEC 61076-2-101

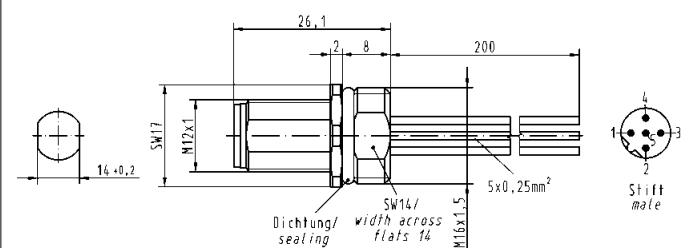

Circular Connectors

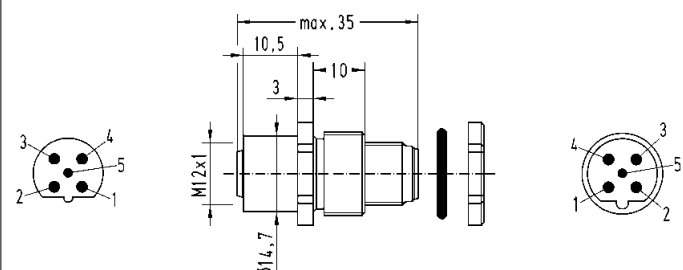
Identification	Part number	Drawing	Dimensions in mm
<p>M12 Panel feed-through</p>  <p>Male B-coding, 20 cm conductors, 0.25 mm²</p> <p>Panel thickness min. 2.0 mm max. 5.0 mm</p>	<p>21 03 339 1301</p>		
<p>M12-male/female panel feed-through B-coding</p>  <p>Panel thickness min. 2.0 mm max. 5.0 mm</p>	<p>21 03 330 1300</p>	 <p>Rated voltage 24 V AC/DC Thread M16 x 1.5</p>	

M12 Panel feed-through B-coded



Mating face

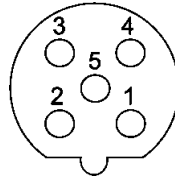

B-coding
Mating face
acc. to IEC 61076-2-101



Circular
Connectors

Identification

Part number

Drawing

Dimensions in mm

M12 Panel feed-through



Female
B-coding, 20 cm conductors,
0.25 mm²

Panel thickness
min. 2.0 mm
max. 5.0 mm

21 03 339 2301

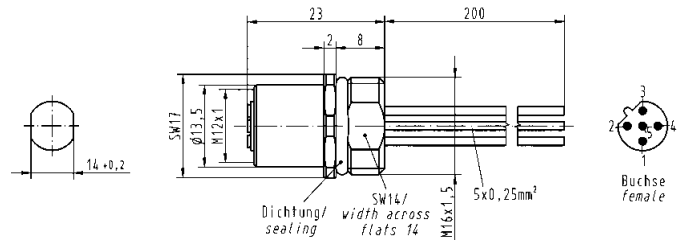



Mating face

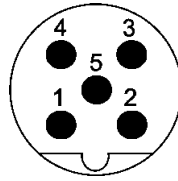

B-coding
Mating face
acc. to IEC 61076-2-101



Technical characteristics: M12 PCB adapter

Degree of protection	IP20, IP67 (mated and locked)	Temperature during connection	-5 °C ... +50 °C
Rated current	max. 4 A (dependant on PCB layout)	Termination	PIH
Rated voltage	50 V	Contact material	Copper alloy
Mating cycles	max. 100	Contact plating (mating side)	Au over Ni
Limiting temperature	-40 °C ... +85 °C	Insulator material	PA

Identification	Part number	Drawing	Dimensions in mm
----------------	-------------	---------	------------------

M12 PCB adapter
Male, B-coding,
straight



5 poles, IP20

21 03 341 1505

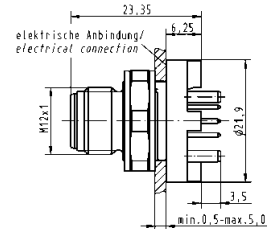
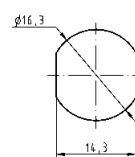
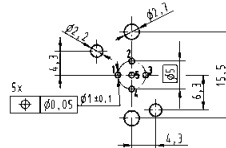

M12 PCB adapter B-coded



Mating face

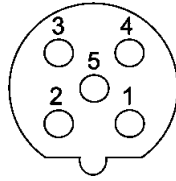

B-coding
Mating face
acc. to IEC 61076-2-101



Circular Connectors

Identification

Part number

Drawing

Dimensions in mm

M12 PCB adapter

Female, B-coding,
straight



5 poles, IP20

21 03 341 2505

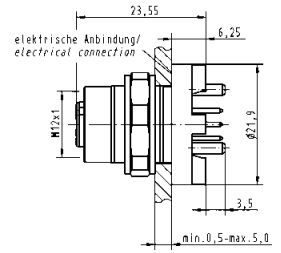
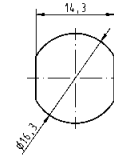
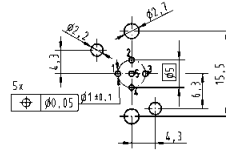

M12 PCB adapter shielded B-coded



Mating face

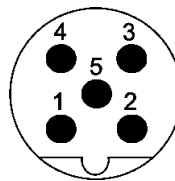

B-coding
Mating face
acc. to IEC 61076-2-101



Circular Connectors

Identification	Part number	Drawing	Dimensions in mm
<p>M12 PCB adapter, shielded</p> <p>Packaging: 60 pieces in a tray Order housing separately</p> <p>Male 5 poles, B-coding</p> <p>Packaging: 1 piece incl. housing</p> <p>Male 5 poles, B-coding, rear mounting 5 poles, B-coding, front mounting</p>	<p>21 03 341 1518*</p> <p>21 03 341 1530*</p> <p>21 03 341 1531*</p>		
<p>Housing</p> <p>Packaging: 10 pieces in a tube</p> <p>for rear mounting</p> <p>for front mounting</p>	<p>21 03 301 1000</p> <p>21 03 301 1001</p>		

M12 PCB adapter shielded B-coded



Mating face

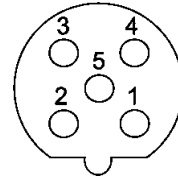

B-coding
Mating face
acc. to IEC 61076-2-101



Circular Connectors

Identification	Part number	Drawing	Dimensions in mm
----------------	-------------	---------	------------------

M12 PCB adapter, shielded

Packaging: 60 pieces in a tray
Order housing separately

Female
5 poles, B-coding

21 03 341 2518*

Packaging: 1 piece incl. housing

Female
5 poles, B-coding, rear mounting
5 poles, B-coding, front mounting

21 03 341 2530*
21 03 341 2531*

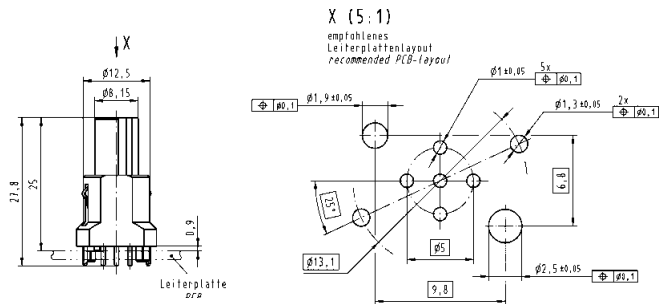

Housing



Packaging: 10 pieces in a tube







for rear mounting

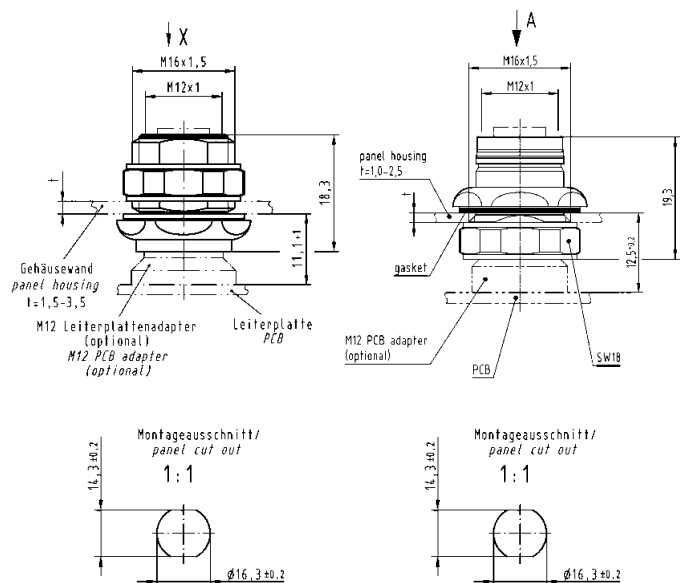



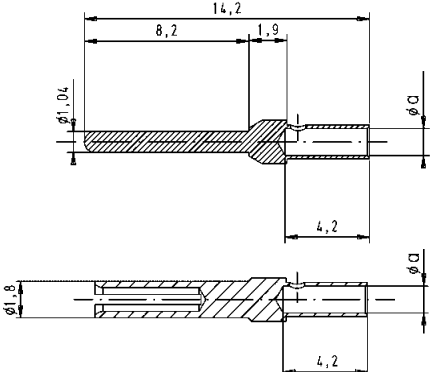

21 03 301 2000

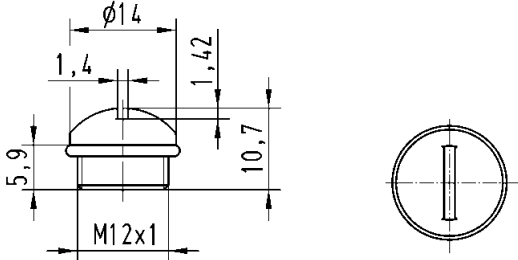

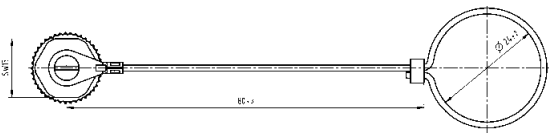

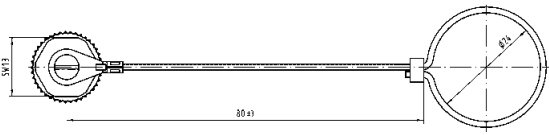

for front mounting

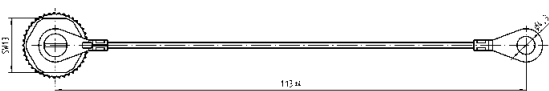
21 03 301 2003

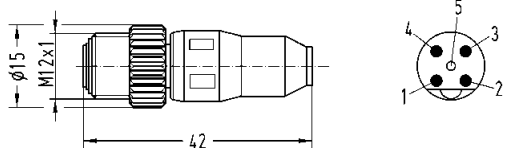

Identification	Part number	Drawing																								
<p>Crimping tool for M12 Crimp</p>	<p>09 99 000 0501</p>																									
<p>Accessories M12 Crimp</p> <p>Locator</p> <p>D-Sub single contacts (500 mating cycles)</p> <p>turned male contacts</p> <p>AWG 22-18 / 0.33-0.82 mm² 09 67 000 3576</p> <p>AWG 24-20 / 0.25-0.52 mm² 09 67 000 8576</p> <p>AWG 26-22 / 0.13-0.33 mm² 09 67 000 5576</p> <p>AWG 28-24 / 0.09-0.25 mm² 09 67 000 7576</p>  <p>turned female contacts</p> <p>AWG 22-18 / 0.33-0.82 mm² 09 67 000 3476</p> <p>AWG 24-20 / 0.25-0.52 mm² 09 67 000 8476</p> <p>AWG 26-22 / 0.13-0.33 mm² 09 67 000 5476</p> <p>AWG 28-24 / 0.09-0.25 mm² 09 67 000 7476</p> 	<p>09 99 000 0531</p>	<p>D-Sub contacts</p> <table border="1" data-bbox="965 638 1468 862"> <thead> <tr> <th>Part number</th> <th>AWG</th> <th>Tool settings</th> </tr> </thead> <tbody> <tr> <td rowspan="3">09 67 000 3x76</td> <td>18</td> <td>6</td> </tr> <tr> <td>20</td> <td>6</td> </tr> <tr> <td>22</td> <td>5</td> </tr> <tr> <td>09 67 000 8x76</td> <td>20, 22, 24</td> <td>6</td> </tr> <tr> <td>09 67 000 5x76</td> <td>22, 24, 26</td> <td>6</td> </tr> </tbody> </table>   <table border="1" data-bbox="1220 1131 1468 1265"> <thead> <tr> <th></th> <th>a</th> </tr> </thead> <tbody> <tr> <td>AWG 22-18</td> <td>1.34</td> </tr> <tr> <td>AWG 24-20</td> <td>1.13</td> </tr> <tr> <td>AWG 26-22</td> <td>0.88</td> </tr> </tbody> </table>	Part number	AWG	Tool settings	09 67 000 3x76	18	6	20	6	22	5	09 67 000 8x76	20, 22, 24	6	09 67 000 5x76	22, 24, 26	6		a	AWG 22-18	1.34	AWG 24-20	1.13	AWG 26-22	0.88
Part number	AWG	Tool settings																								
09 67 000 3x76	18	6																								
	20	6																								
	22	5																								
09 67 000 8x76	20, 22, 24	6																								
09 67 000 5x76	22, 24, 26	6																								
	a																									
AWG 22-18	1.34																									
AWG 24-20	1.13																									
AWG 26-22	0.88																									
<p>M12 dynamometric screwdriver</p> <p>Tightening torque 0.6 Nm</p> <p>for M12-S SW 13 09 99 000 0382</p> <p>for M12-L SW 17 09 99 000 0384</p>	<p>09 99 000 0382</p> <p>09 99 000 0384</p>																									
<p>Cap M12</p> <p>for IP65 / 67</p> <p>Seals material Viton</p> <p>Plastic cap for female</p> 	<p>21 01 000 0003</p>																									

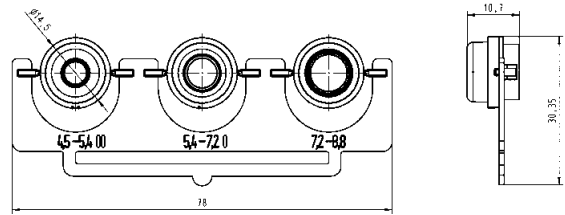
Identification	Part number	Drawing	Dimensions in mm
<p>Cap metal M12 for IP65 / 67 M12 metal cap for male side with cord</p> 	<p>21 01 000 0033</p>		
<p>Cap metal M12 for IP65 / 67 M12 metal cap for male side with cable clip</p> 	<p>21 01 000 0038</p>		
<p>Cap metal M12 for IP65 / 67 M12 metal cap for female side with cord</p> 	<p>21 01 000 0030</p>		
<p>Cap metal M12 for IP65 / 67 M12 metal cap for female side with cable clip</p> 	<p>21 01 000 0031</p>		

Identification	Part number	Drawing	Dimensions in mm
<p>M12-male moving load B-coding</p> 	<p>21 03 030 1300</p>		
<p>HARTING M12 T-Coupler</p>	<p>21 03 341 6401</p>		
<p>Seal M12-L unshielded for 4.7 - 6 mm cable Ø for 6 - 8 mm cable Ø</p> 	<p>21 01 010 2015 21 01 010 2007</p>		
<p>Set of seals M12-L shielded for 4.5 - 5.4 mm cable Ø for 5.4 - 7.2 mm cable Ø for 7.2 - 8.8 mm cable Ø</p> 	<p>21 01 010 2017</p>		
<p>Accessories M12 Lock nut</p>	<p>21 01 000 0018</p>		



A large grid of graph paper for taking notes, consisting of a 20x30 grid of small squares.

Specifications IEC 60352-4

Approval

Mating face

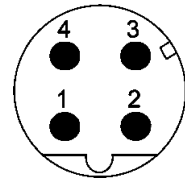

D-coding
Mating face
acc. to IEC 61076-2-101



Technical characteristics M12 – D-coding

Type M12 D-coded	HARAX® M12 L shielded	M12 Crimp	M12 preLink®
------------------	-----------------------	-----------	--------------

General data

Conductor cross section	0.14 - 0.34 mm ² AWG 26-22 0.34 - 0.5 mm ² AWG 22-20	0.13 - 0.75 mm ² AWG 26-18	0.10 - 0.34 mm ² AWG 27-22
Diameter of individual strands	≥ 0.1 mm	X	≥ 0.1 mm
Conductor insulation material	PVC/PE	X	PVC/PE
Conductor diameter	1.2 - 2.0 mm	2.0 - 2.3 mm	0.8 - 1.6 mm
Cable diameter	4.5 - 8.8 mm	4 poles: 4.5 - 8.8 mm 5 poles: 4.5 - 8.8 mm	6.3 - 6.7 mm
Temperature range	-40 °C ... +85 °C	-40 °C ... +85 °C	-40 °C ... +85 °C
Temperature during connection	-5 °C ... +50 °C	-5 °C ... +50 °C	–
Degree of protection	IP65 / 67	IP67	IP65 / IP67
Mating cycles	100	500	250
Tightening torque connector / Hexagonal wrench	0.6 Nm / SW 17	0.6 Nm / SW 17	0.6 Nm / SW 17

Electrical characteristics

Rated current	4 A	4 A	1 A
Rated voltage	50 V	250 V	48 V
Rated impulse voltage	1.5 kV	1.5 kV	1.5 kV
Contact resistance	10 mΩ	10 mΩ	10 mΩ
Insulation resistance	10 ⁸ Ω	10 ⁸ Ω	10 ⁸ Ω
Pollution degree	3	3	3
Overvoltage category	3	3	3
Isolation group	1	1	–
Transmission performance (Category)	Cat. 5	Cat. 5	Cat. 5

Materials

Contact material	Brass	Brass	Brass
Contact plating	Gold	Gold	Gold
Contact carrier material	PA unreinforced	PA	–
Housing material	PA unreinforced	PA	Zinc die-cast

Technical characteristics M12 – D-coding

Current carrying capacity The current carrying capacity is limited by maximum temperature of materials for inserts and contacts including terminals. The current capacity-curve is valid for continuous, not interrupted current-loaded contacts of connectors when simultaneous power on all contacts is given, without exceeding the maximum temperature.

Control and test procedures according to DIN IEC 60512-5.

M12-L
3 poles, 4 poles
1 = Wire gauge 0.34 mm²
2 = Wire gauge 0.75 mm²

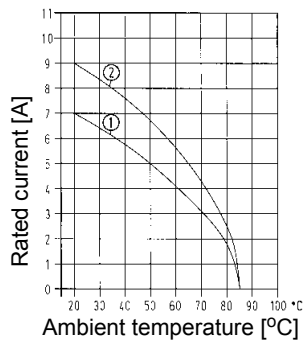

M12, Crimp 1 = Wire gauge 0.34 mm² / 0.5 mm²

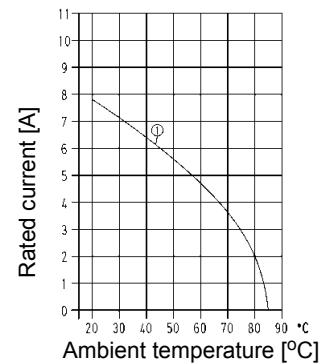

Technical characteristics M12 – D-coding, PCB adapter

M12, D-coding, straight, female, 4 poles
Wire gauge 0.5 mm²

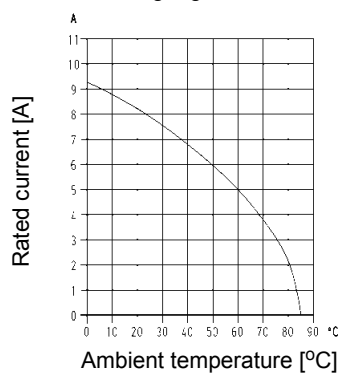

M12, D-coding, angled, female, 4 poles
Wire gauge AWG 22

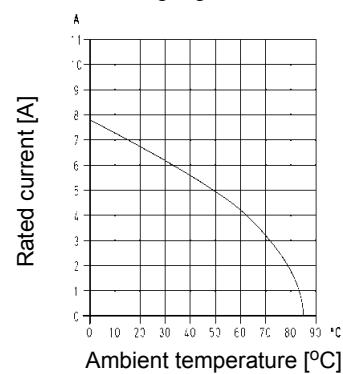



Mating face

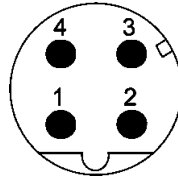

D-coding
Mating face
acc. to IEC 61076-2-101



Applications / Advantages

- D-coding for Ethernet/Profinet applications
- Robust design
- 360° shielding termination
- Transmission performance Cat. 5

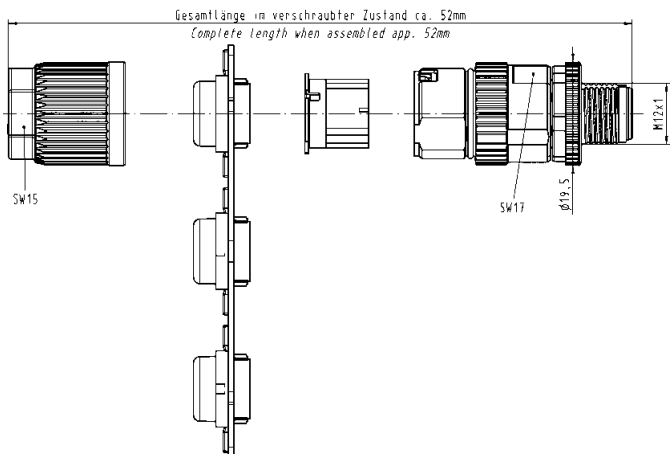
Identification	Part number	Drawing	Dimensions in mm
<p>HARAX® M12-L, shielded</p>  <p>Male 4 poles, D-coding 0.14 - 0.34 mm², AWG 26 - 22</p> <p>Male 4 poles, D-coding 0.34 - 0.5 mm², AWG 22 - 20</p>	<p>21 03 281 1405</p> <p>21 03 282 1405</p>	 <p>Gesamtlänge im verschraubter Zustand ca. 52mm Complete length when assembled app. 52mm</p> <p>SW15</p> <p>SW17</p> <p>∅19.5</p> <p>M12x1</p>	



Mating face

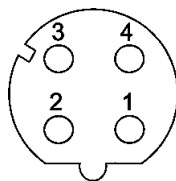

D-coding
Mating face
acc. to IEC 61076-2-101



Identification

Part number

Drawing

Dimensions in mm

HARAX® M12-L, shielded



Female
4 poles, D-coding
0.14 - 0.34 mm², AWG 26 - 22

Female
4 poles, D-coding
0.34 - 0.5 mm², AWG 22 - 20

21 03 281 2405

21 03 282 2405

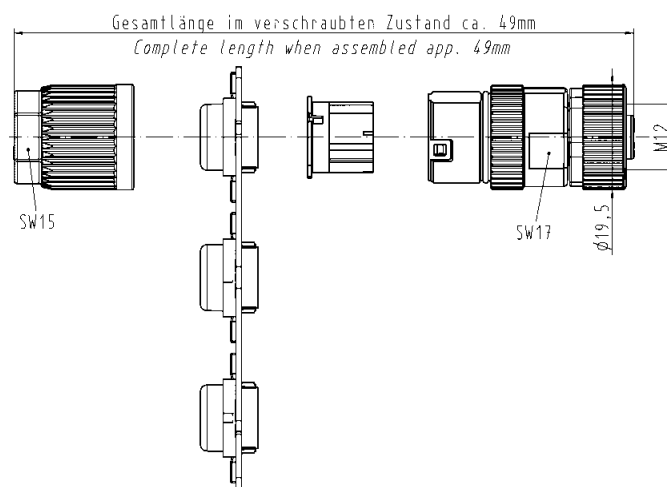

M12 Crimp D-coded



Circular Connectors



Mating face

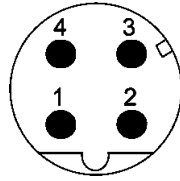

D-coding
Mating face
acc. to IEC 61076-2-101



Identification	Part number	Drawing	Dimensions in mm
----------------	-------------	---------	------------------

M12 Crimp, shielded



Male
4 poles, D-coding

21 03 882 1415

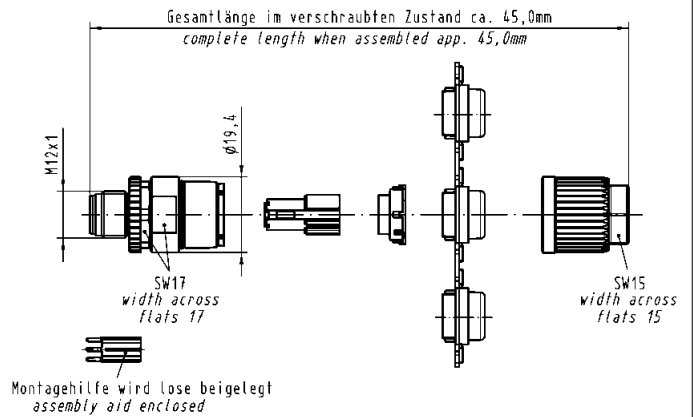

M12 Crimp D-coded



Mating face

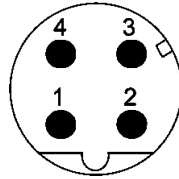

D-coding
Mating face
acc. to IEC 61076-2-101



Circular
Connectors

Identification

Part number

Drawing

Dimensions in mm

M12 Crimp Slim design, shielded



Male
4 poles, D-coding
Cable: 5.7 - 8.8 mm
outer diameter

21 03 881 1405*

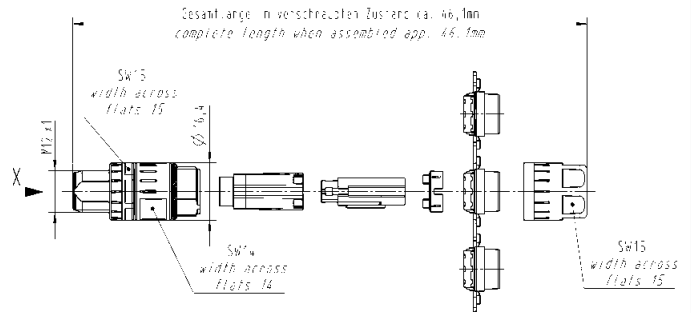

M12 Crimp, shielded



Male
4 poles, D-coding
angled

21 03 882 3405*

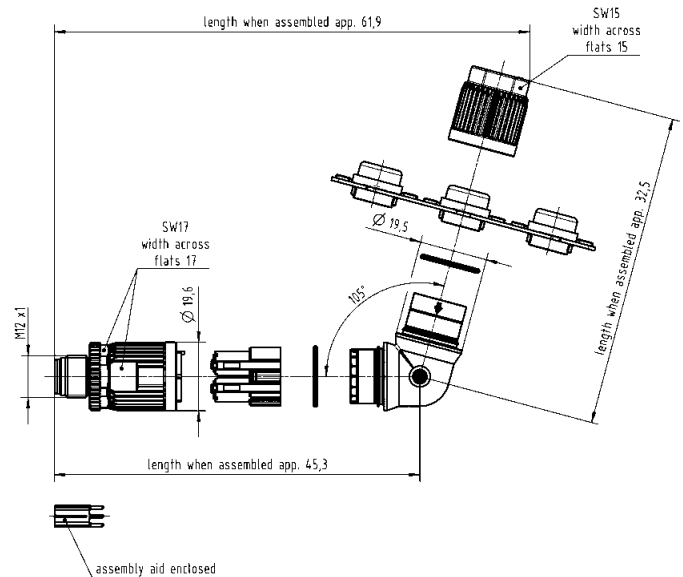

M12 Crimp D-coded



Mating face

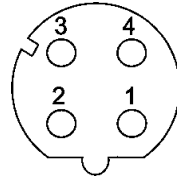

D-coding
Mating face
acc. to IEC 61076-2-101



Circular
Connectors

Identification Part number Drawing Dimensions in mm

M12 Crimp, shielded



Female
4 poles, D-coding

21 03 882 2405

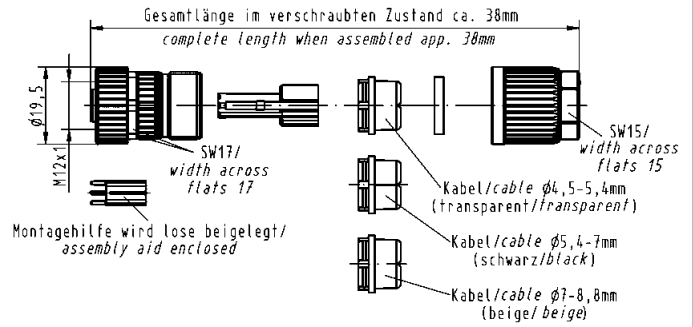



Mating face

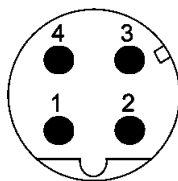

D-coding
Mating face
acc. to IEC 61076-2-101



Identification	Part number	Drawing	Dimensions in mm
<p>preLink® M12 housing</p>	20 82 000 1210	<p>Technical drawing of the M12 housing. Dimensions include: total length 64,5; thread length 8,502; main body length 49,1 (+0,4/-0,3); and overall length 56,6 (+0,5/-0,3). Materials are specified as Metall/metal grau/grey. Features include M12x1 thread, SW17 hex keys, and SW19 hex key.</p>	
<p>preLink® M12 male module</p> <p>Male 4 poles, D-coding</p>	20 82 005 1214	<p>Technical drawing of the M12 male module. Dimensions include: length 43,55; width 16; and diameter 8,35 (+0,1/-0,05). Materials are specified as Metall/metal grau/grey and Kunststoff/plastic grau/grey. Features include 4x contact positions with diameter 0,1 A.</p>	
<p>preLink® terminal module (Pack with 10 pieces) terminal block with IDC termination</p> <p>Number of contacts: 8</p> <p>Conductor cross section: AWG 22/23 (24) solid and stranded</p> <p>Conductor diameter: Ø 1.3 - 1.6 mm</p> <p>Colour: yellow</p> <p>Conductor cross section: AWG 26/27 solid and stranded</p> <p>Conductor diameter: Ø 0.8 - 1.1 mm</p> <p>Colour: white</p>	<p>20 82 000 0001</p> <p>20 82 000 0003</p>	<p>Technical drawing of the terminal module showing dimensions: height 10 and width 10,6. A second drawing shows a side view with height 9,5 and width 215. An assembly tool is also shown.</p>	
<p>Assembly tool</p>	20 82 000 9901	<p>Technical drawing of the assembly tool, showing a length of 215 mm.</p>	



Male, 4 poles

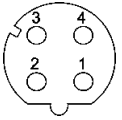

Female, 4 poles



Technical characteristics

System cables with M12 circular connectors shielded, D-coding

	4 poles	
	PVC	PUR
Rated voltage	max. 160 V AC/DC	max. 160 V AC/DC
Rated current / contact	max. 4 A at +40 °C	max. 4 A at +40 °C
Screw locking	M12x1, self securing	M12x1, self securing
Recommended torque	0.6 Nm	0.6 Nm
Temperature range (working and storage)	-30 °C ... +80 °C	-30 °C ... +80 °C
Degree of protection	IP67	IP67
Number of wires / wire gauge	4 x 0.34 mm ²	4 x 0.34 mm ²
Conductor insulation	PE (ye, wh, og, bu)	PE (ye, wh, og, bu)
Arrangement of insulated strands	7 x Ø 0.25 mm (AWG 22)	7 x Ø 0.25 mm (AWG 22)
Sheath	PVC	PUR (UL, CSA)
Sheath colour	green	green
Outer diameter	Ø 6.5 ± 0.2 mm	Ø 6.5 ± 0.2 mm
Useable as trailing cable	no	yes
Halogen free acc. to	–	IEC 60754
Flame retardant acc. to	UL 1685 (CSA FT4)	IEC 60332-1-2 und UL 2556 VW1
Oil-resistant	IEC 80811-2-1 (4h/70°C)	IEC 60811-2-1 und UL13

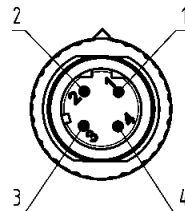

Loading-Plan:

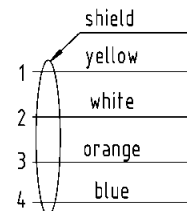

M12 System cables, D-coding, 4 poles



Male, 4 poles

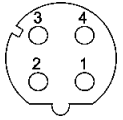

Female, 4 poles



Circular Connectors

Part number definition



Connector 1

- 92 Male straight
- 93 Female straight
- 94 Male angled
- 95 Female angled

Connector 2

- 00 No connector
- 92 Male straight
- 93 Female straight
- 94 Male angled
- 95 Female angled

Number of contacts
4 4 poles

Cable material
05 PVC
77 PUR

Preferred length*

- 005 0.5 m
- 010 1.0 m
- 015 1.5 m
- 020 2.0 m
- 050 5.0 m
- 075 7.5 m
- 100 10.0 m

* Other length on request



Mating face

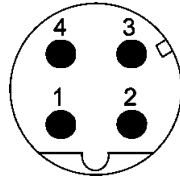

D-coding
Mating face
acc. to IEC 61076-2-101



Applications / Advantages

- D-coding for Ethernet/Profinet applications
- Patent HARAX® fast termination
- Robust design
- 360° shielding termination
- Transmission performance Cat. 5

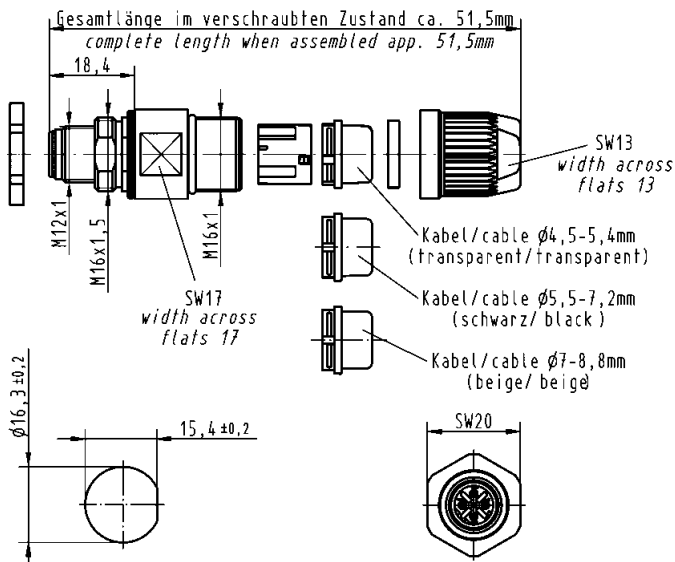
Identification	Part number	Drawing	Dimensions in mm
<p>HARAX® Panel feed-through</p>  <p>Male 4 poles, D-coding 0.14 - 0.34 mm² / AWG 26 - 22</p> <p>Panel thickness min. 2.5 mm max. 4.5 mm</p>	<p>21 03 381 1425</p>	 <p>Gesamtlänge im verschraubten Zustand ca. 51,5mm complete length when assembled app. 51,5mm</p> <p>18,4</p> <p>M12x1</p> <p>M16x1,5</p> <p>M16x1</p> <p>SW17 width across flats 17</p> <p>SW13 width across flats 13</p> <p>Kabel/cable ϕ4,5-5,4mm (transparent/transparent)</p> <p>Kabel/cable ϕ5,5-7,2mm (schwarz/black)</p> <p>Kabel/cable ϕ7-8,8mm (beige/beige)</p> <p>ϕ16,3\pm0,2</p> <p>15,4\pm0,2</p> <p>SW20</p>	

M12 Panel feed-through HARAX® D-coded



Mating face

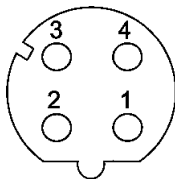

D-coding
Mating face
acc. to IEC 61076-2-101



Circular
Connectors

Identification

Part number

Drawing

Dimensions in mm

HARAX® Panel feed-through



21 03 381 2425

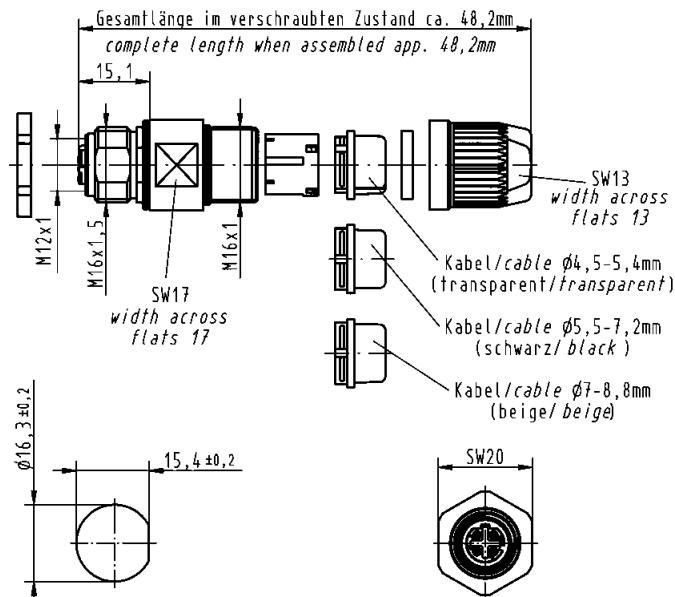

Female
4 poles, D-coding
0.14 - 0.34 mm² / AWG 26 - 22

Panel thickness
min. 2.5 mm
max. 4.5 mm

M12 Panel feed-through Crimp D-coded



Mating face

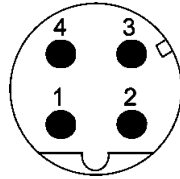

D-coding
Mating face
acc. to IEC 61076-2-101



Identification

Part number

Drawing

Dimensions in mm

M12 Panel feed-through Crimp



Male
4 poles, D-coding

Panel thickness
min. 2.5 mm
max. 4.5 mm

21 03 882 1425

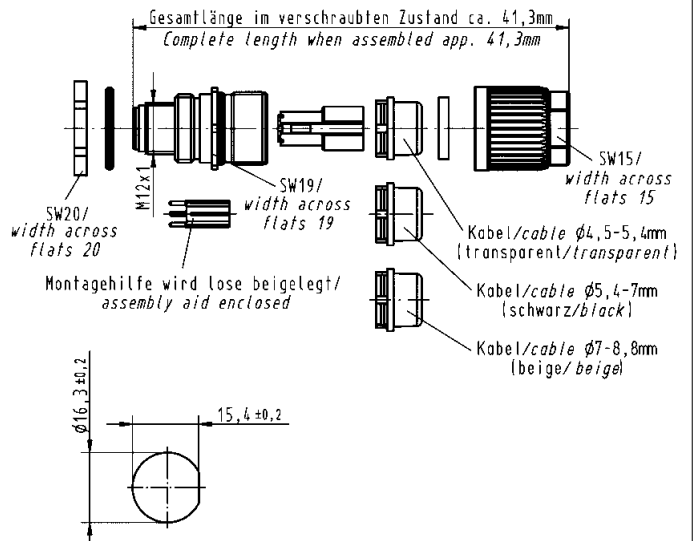

M12 Panel feed-through Crimp D-coded



Mating face

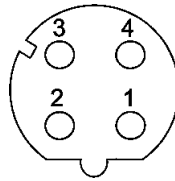

D-coding
Mating face
acc. to IEC 61076-2-101



Circular
Connectors

Identification

Part number

Drawing

Dimensions in mm

M12 Panel feed-through Crimp



Female
4 poles, D-coding

Panel thickness
min. 2.5 mm
max. 4.5 mm

21 03 882 2425

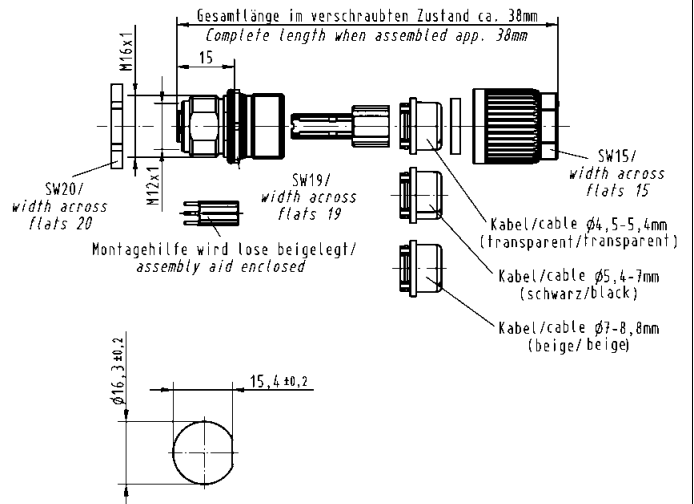

M12 Panel feed-through D-coded



Circular Connectors



Mating face

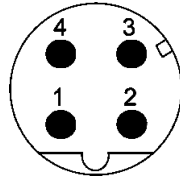

D-coding
Mating face
acc. to IEC 61076-2-101



Identification	Part number	Drawing	Dimensions in mm
----------------	-------------	---------	------------------

M12 Panel feed-through



21 03 371 1403

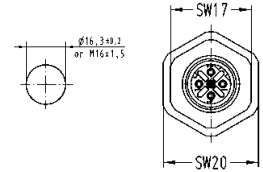
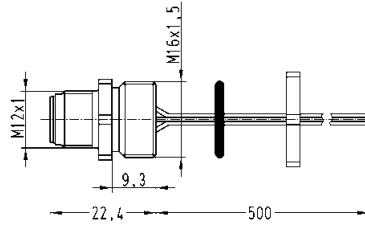

Male
D-coding
50 cm conductors, AWG 22, 4 poles

Panel thickness
min. 2.0 mm
max. 5.0 mm

M12 Panel feed-through D-coded



Mating face

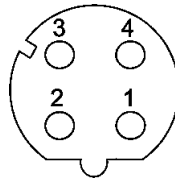

D-coding
Mating face
acc. to IEC 61076-2-101



Circular
Connectors

Identification

Part number

Drawing

Dimensions in mm

M12 Panel feed-through



21 03 371 2403

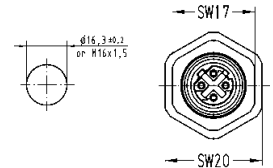
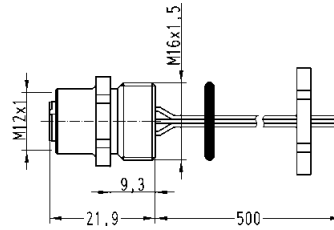

Female
D-coding
50 cm conductors, AWG 22, 4 poles

Panel thickness
min. 2.0 mm
max. 5.0 mm

M12 Panel feed-through D-coded



Mating face

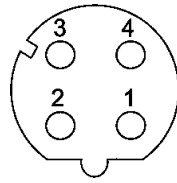

D-coding
Mating face
acc. to IEC 61076-2-101



Circular
Connectors

Identification	Part number	Drawing	Dimensions in mm
----------------	-------------	---------	------------------

**M12 Female-RJ45
Panel feed-through**



4 poles, D-coding
angled

Panel thickness
min. 2.1 mm
max. 4.5 mm

21 03 381 4401*

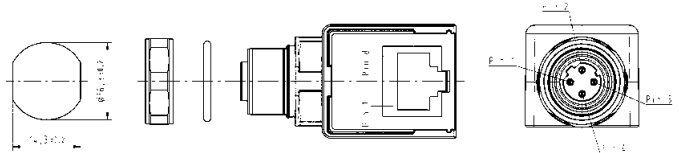

**M12 Female-RJ45
Panel feed-through**



4 poles, D-coding
straight

Panel thickness
min. 2.1 mm
max. 4.5 mm

21 03 381 2401*

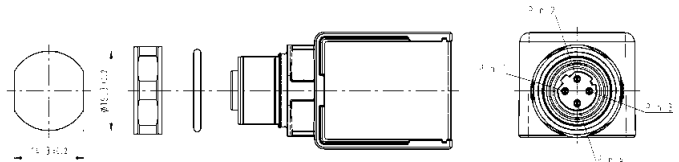

M12 Panel feed-through D-coded



Mating face

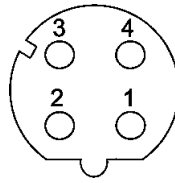

D-coding
Mating face
acc. to IEC 61076-2-101



Circular
Connectors

Identification Part number Drawing Dimensions in mm

M12 Gender Changer
Female-Female

4 poles, D-coding
8 poles, X-coding

21 03 381 6402*

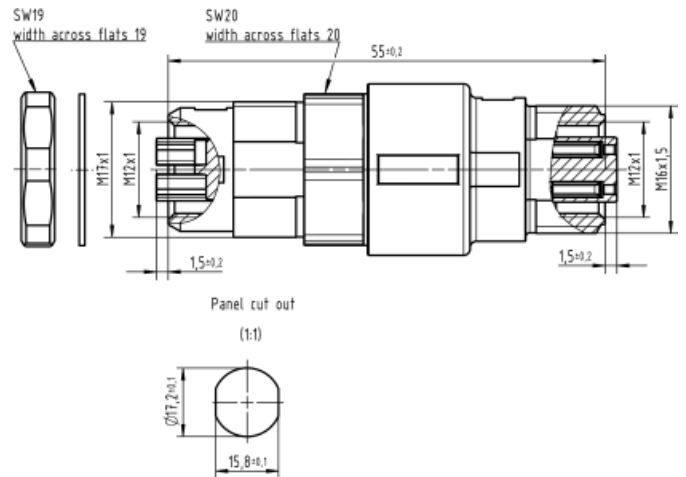

M12 Gender Changer
Female-Female

4 poles, D-coding
Cat. 5

21 03 381 6401*

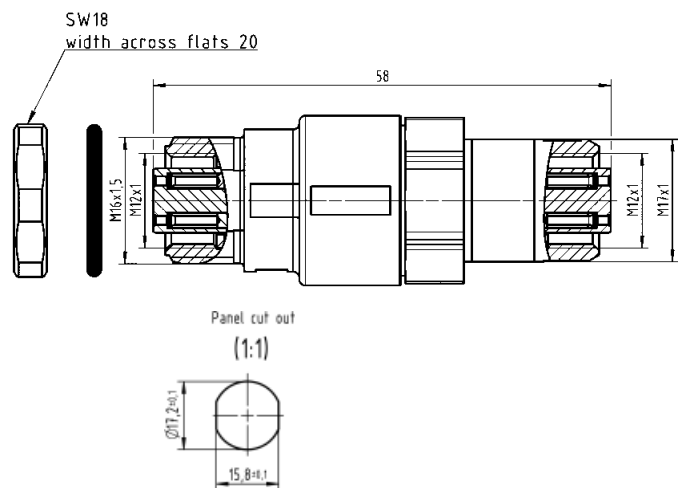

Wall bracket



21 01 000 0036

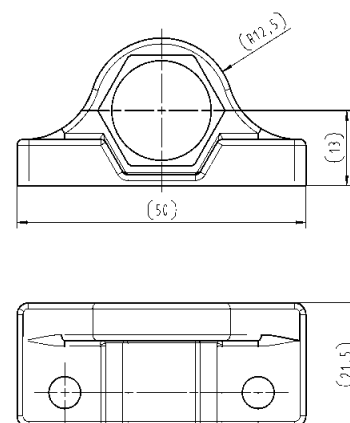



Mating face

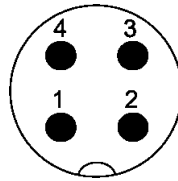

D-coding
Mating face
acc. to IEC 61076-2-101



Technical characteristics: M12 PCB adapter D-coded angled

Degree of protection	IP20, IP67 (mated and locked)	Temperature during connection	-5 °C ... +50 °C
Rated current	max. 4 A (dependant on PCB layout)	Termination	Reflow
Rated voltage	50 V	Contact material	Copper alloy
Mating cycles	max. 100	Contact plating (mating side)	Au over Ni
Limiting temperature	-40 °C ... +85 °C	Insulator material	LCP

Identification	Part number	Drawing	Dimensions in mm
----------------	-------------	---------	------------------

M12 PCB adapter
Male, D-coding,
straight



4 poles, IP67

21 03 371 1400

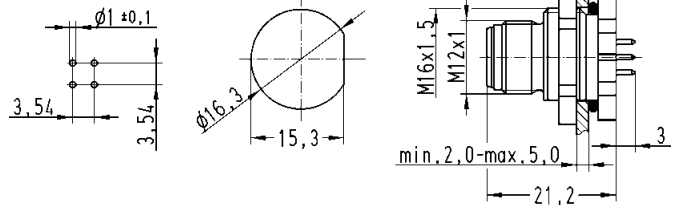

M12 PCB adapter D-coded



Mating face

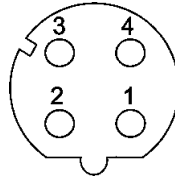

D-coding
Mating face
acc. to IEC 61076-2-101



Circular
Connectors

Identification

Part number

Drawing

Dimensions in mm

M12 PCB adapter
Female, D-coding,
straight



4 poles, IP67

21 03 371 2415

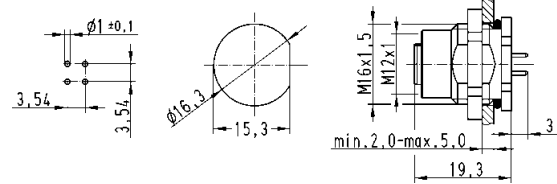

4 poles, IP20
4 poles, IP67

21 03 381 6410
21 03 381 6420

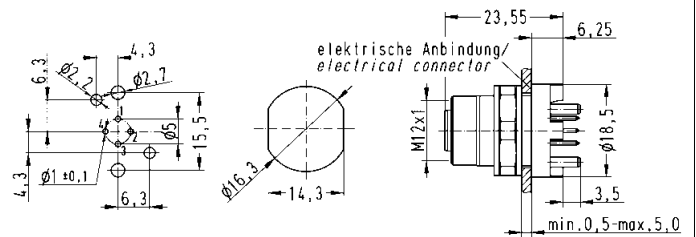

M12 PCB adapter D-coded



Mating face

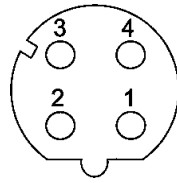

D-coding
Mating face
acc. to IEC 61076-2-101



Identification	Part number	Drawing	Dimensions in mm
----------------	-------------	---------	------------------

M12 PCB adapter

Female, D-coding,
angled, 4 poles

without fixing hole

IP20
IP20
IP67

21 03 381 4410¹⁾
21 03 381 4411²⁾
21 03 381 4430¹⁾



with fixing hole

IP20
IP20
IP67

21 03 381 4412¹⁾
21 03 381 4413²⁾
21 03 381 4432¹⁾

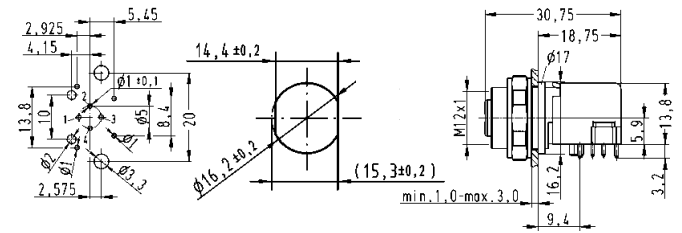
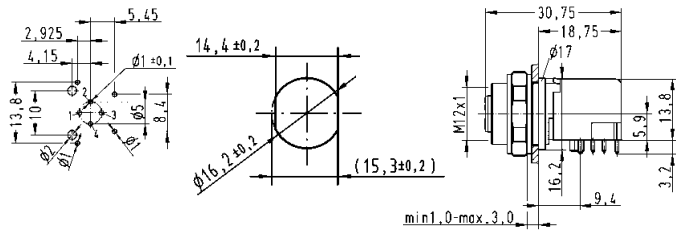

1) Cable direction to the right

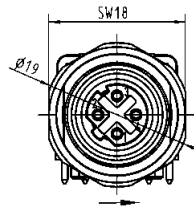

2) Cable direction to the bottom

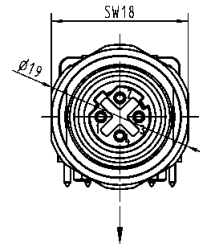

M12 PCB adapter shielded D-coded



Mating face

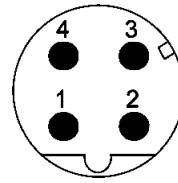

D-coding
Mating face
acc. to IEC 61076-2-101



Circular Connectors

Identification

Part number

Drawing

Dimensions in mm

M12 PCB adapter, shielded

Packaging: 60 pieces in a tray
Order housing separately

Male
4 poles, D-coding

21 03 381 1418*

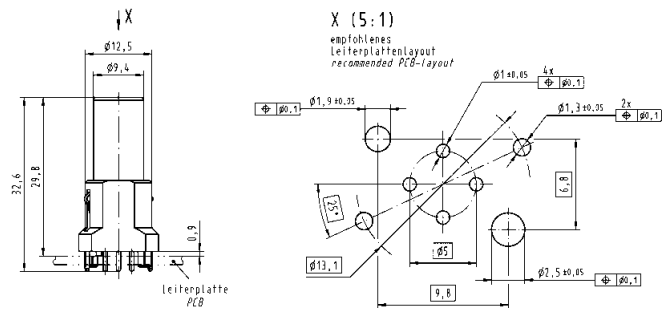

Packaging: 1 piece incl. housing

Male
4 poles, D-coding, rear mounting
4 poles, D-coding, front mounting

21 03 381 1430*
21 03 381 1431*

Housing



Packaging: 10 pieces in a tube

for rear mounting

21 03 301 1000

for front mounting

21 03 301 1001

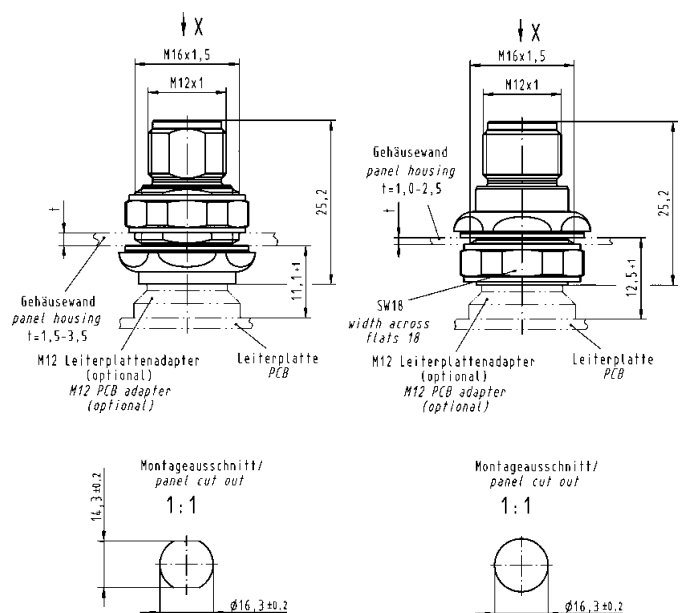

M12 PCB adapter shielded D-coded



Mating face

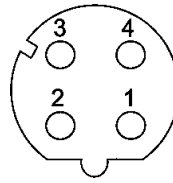









D-coding
Mating face
acc. to IEC 61076-2-101

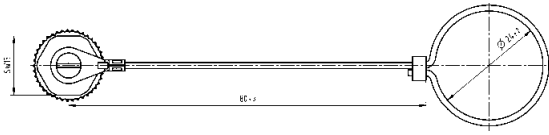

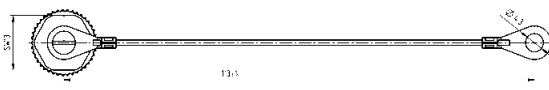
Circular Connectors

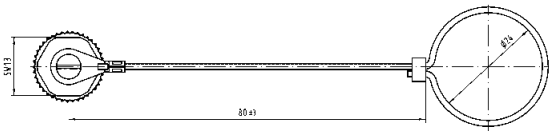
Identification	Part number	Drawing	Dimensions in mm
<p>M12 PCB adapter, shielded</p> <p>Packaging: 60 pieces in a tray Order housing separately</p> <p>Female 4 poles, D-coding</p> <p>Packaging: 1 piece incl. housing</p> <p>Female 4 poles, D-coding, rear mounting 4 poles, D-coding, front mounting</p>	<p>21 03 381 2418*</p> <p>21 03 381 2430*</p> <p>21 03 381 2431*</p>		
<p>Housing</p> <p>Packaging: 10 pieces in a tube</p> <p>for rear mounting</p> <p>for front mounting</p>	<p>21 03 301 2000</p> <p>21 03 301 2003</p>		

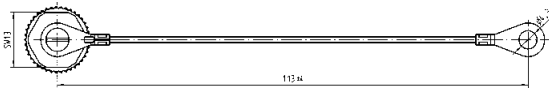
Identification	Part number	Drawing																								
<p>Crimping tool for M12 Crimp</p>	09 99 000 0501																									
<p>Accessories M12 Crimp</p> <p>Locator</p> <p>D-Sub single contacts (500 mating cycles)</p> <p>turned male contacts</p> <p>AWG 22-18 / 0.33-0.82 mm²</p> <p>AWG 24-20 / 0.25-0.52 mm²</p> <p>AWG 26-22 / 0.13-0.33 mm²</p> <p>AWG 28-24 / 0.09-0.25 mm²</p> <p>turned female contacts</p> <p>AWG 22-18 / 0.33-0.82 mm²</p> <p>AWG 24-20 / 0.25-0.52 mm²</p> <p>AWG 26-22 / 0.13-0.33 mm²</p> <p>AWG 28-24 / 0.09-0.25 mm²</p>	09 99 000 0531	<p>D-Sub contacts</p> <table border="1"> <thead> <tr> <th>Part number</th> <th>AWG</th> <th>Tool settings</th> </tr> </thead> <tbody> <tr> <td rowspan="3">09 67 000 3x76</td> <td>18</td> <td>6</td> </tr> <tr> <td>20</td> <td>6</td> </tr> <tr> <td>22</td> <td>5</td> </tr> <tr> <td>09 67 000 8x76</td> <td>20, 22, 24</td> <td>6</td> </tr> <tr> <td>09 67 000 5x76</td> <td>22, 24, 26</td> <td>6</td> </tr> </tbody> </table> <table border="1"> <thead> <tr> <th></th> <th>a</th> </tr> </thead> <tbody> <tr> <td>AWG 22-18</td> <td>1.34</td> </tr> <tr> <td>AWG 24-20</td> <td>1.13</td> </tr> <tr> <td>AWG 26-22</td> <td>0.88</td> </tr> </tbody> </table>	Part number	AWG	Tool settings	09 67 000 3x76	18	6	20	6	22	5	09 67 000 8x76	20, 22, 24	6	09 67 000 5x76	22, 24, 26	6		a	AWG 22-18	1.34	AWG 24-20	1.13	AWG 26-22	0.88
Part number	AWG	Tool settings																								
09 67 000 3x76	18	6																								
	20	6																								
	22	5																								
09 67 000 8x76	20, 22, 24	6																								
09 67 000 5x76	22, 24, 26	6																								
	a																									
AWG 22-18	1.34																									
AWG 24-20	1.13																									
AWG 26-22	0.88																									
<p>M12 dynamometric screwdriver</p> <p>Tightening torque 0.6 Nm</p> <p>for M12 Slim design SW 15</p> <p>for M12-L SW 17</p>	<p>09 99 000 0646</p> <p>09 99 000 0384</p>																									
<p>Set of seals M12-L shielded</p> <p>for 4.5 - 5.4 mm cable Ø</p> <p>for 5.4 - 7.2 mm cable Ø</p> <p>for 7.2 - 8.8 mm cable Ø</p>	21 01 010 2017																									
<p>Accessories M12</p> <p>Lock nut</p>	21 01 000 0018																									

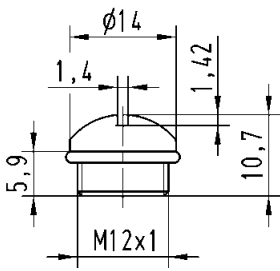
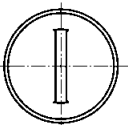
Identification	Part number	Drawing	Dimensions in mm
<p>Cap metal M12 for IP65 / 67 M12 metal cap for male side with cord</p> 	<p>21 01 000 0033</p>		
<p>Cap metal M12 for IP65 / 67 M12 metal cap for male side with cable clip</p> 	<p>21 01 000 0038</p>		
<p>Cap metal M12 for IP65 / 67 M12 metal cap for female side with cord</p> 	<p>21 01 000 0030</p>		
<p>Cap metal M12 for IP65 / 67 M12 metal cap for female side with cable clip</p> 	<p>21 01 000 0031</p>		
<p>Cap M12 for IP65 / 67 Seals material Viton Plastic cap for female</p> 	<p>21 01 000 0003</p>		

Specifications IEC 60352-4

Approval



Mating face

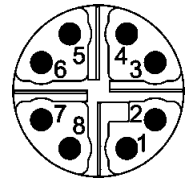

X-coding
Mating face
acc. to IEC 61076-2-109

Technical characteristics M12 – X-coding

Type M12 X-coded	<i>har-speed M12</i> <i>har-speed M12 Slim design</i>
-------------------------	--

General data

Conductor cross section	0.08 - 0.25 mm ² AWG 28-23
Diameter of individual strands	–
Conductor insulation material	–
Conductor diameter	0.33 - 0.61 mm
Cable diameter	5.7 - 8.8 mm
Temperature range	-40 °C ... +85 °C
Temperature during connection	-5 °C ... +50 °C
Degree of protection	IP65 / 67
Mating cycles	500
Tightening torque connector / hexagonal wrench	0.6 Nm / SW 15

Electrical characteristics

Rated current	0.5 A
Rated voltage	48 V
Rated impulse voltage	0.8 kV
Contact resistance	15 mΩ
Insulation resistance	10 ⁸ Ω
Pollution degree	3
Overvoltage category	3
Isolation group	1
Transmission performance (Category)	Cat. 6 _A

Materials

Contact material	Brass
Contact plating	Gold
Contact carrier material	LCP
Housing material	ZP410

Technical characteristics M12 – X-coding

Current carrying capacity The current carrying capacity is limited by maximum temperature of materials for inserts and contacts including terminals. The current capacity-curve is valid for continuous, not interrupted current-loaded contacts of connectors when simultaneous power on all contacts is given, without exceeding the maximum temperature.

Control and test procedures according to DIN IEC 60512-9-1.

har-speed M12
8 poles

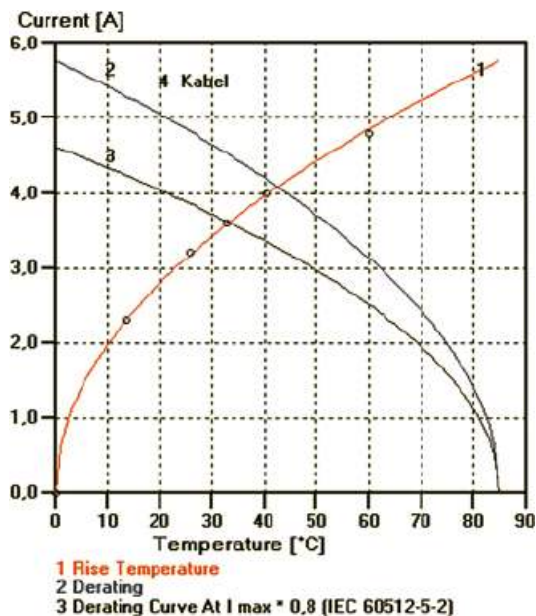

har-speed M12
PCB adapter

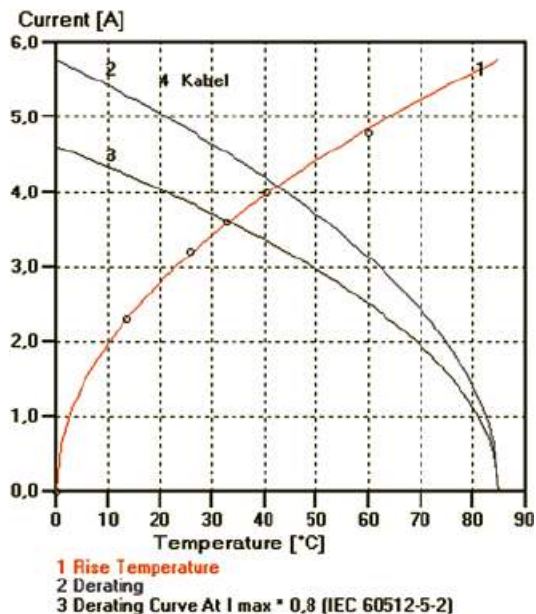



Mating face

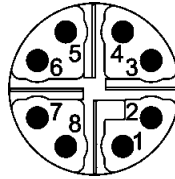

X-coding
Mating face
acc. to IEC 61076-2-109



Applications / Advantages

- High-Speed Ethernet applications for process automatization, e.g. camera system for process control in the production
- Maximum data rates through the configuration of the contacts in conformance with Ethernet technology. Transfer class E_A for 1 and 10 Gigabit
- Perfect shielding through paired shielding of the contacts
- Overmoulded system cables in various lengths

Identification

Part number

Drawing

Dimensions in mm

har-speed M12 Slim design



Male
straight version
8 poles, Cat. 6_A
Cable diameter: 5.7 - 8.8 mm

21 03 881 1805

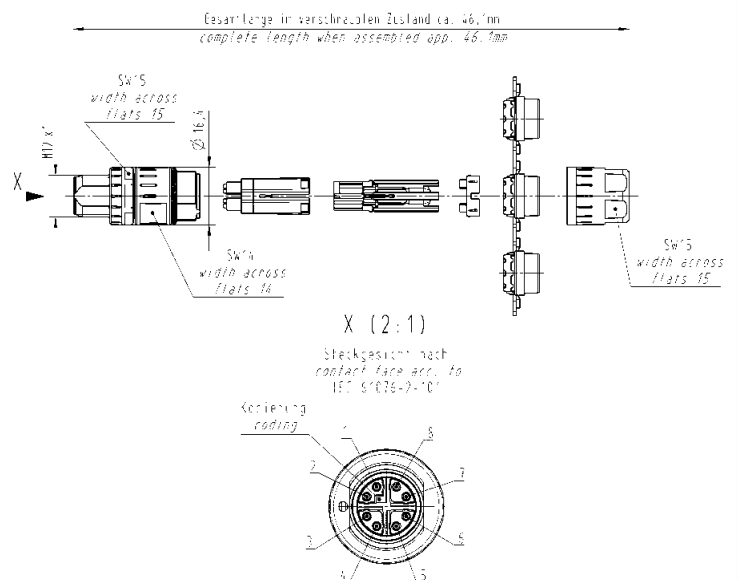



Mating face

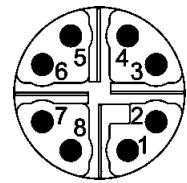

X-coding Mating face acc. to IEC 61 076-2-101



Ha-VIS preLink® M12 connector X-coding

Advantages

- M12 Ethernet-Data connector suitable for industry
- Robust design
- 360° shielding
- Category of transmission Cat. 6A
- Suitable for solid and stranded wires
- Suitable for PoE (IEEE 802.3af) and PoE+ (IEEE 802.3at)

Technical characteristics

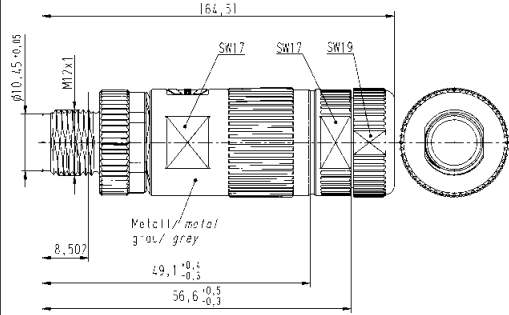
Connector type	M12 X-coding acc. to IEC 61 076-2-101
Number of contacts	8
Transmission category	Category 6A, Class EA, suitable for 1/10 Gigabit Ethernet
Transmission performance	Category 6A / Class EA up to 500 MHz acc. to ISO/IEC 11 801:2002, EN 50 173-1
Transmission rate	10/100 Mbit/s and 1/10 Gbit/s
Shielding	fully shielded, 360° shielding contact
Mounting	IDC termination
Cable termination for preLink® Connectable cables	terminal module, yellow, 20 82 000 0001
– Conductor cross section	AWG 23 ... AWG 22 (solid and stranded)
– Conductor diameter	1.3 ... 1.6 mm
Cable termination for preLink® Connectable cables	terminal module, white, 20 82 000 0003
– Conductor cross section	AWG 27 ... AWG 26 (solid and stranded)
– Conductor diameter	0.8 ... 1.1 mm
Cable diameter	5 ... 9 mm
Degree of protection	IP65 / IP67
Mating cycles	min. 750
Temperature range	-40 °C ... +70 °C
Housing material	Zinc die-cast, nickel-plated

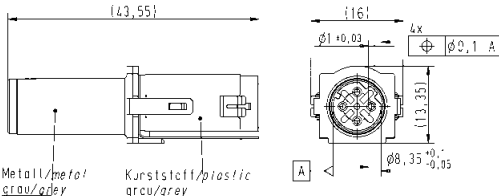
Identification	Part number	Drawing	Dimensions in mm
preLink® M12 housing 	20 82 000 1210		
preLink® M12 male module Male 8 poles, X-coding 	20 82 006 1218		
preLink® M12 connector set X-coding	20 82 005 0002		
Ha-VIS preLink® RJ45 terminal module AWG 22/23, yellow ¹⁾ AWG 26/27, white ¹⁾	20 82 000 0001 20 82 000 0003		
Ha-VIS preLink® assembly tool	20 82 000 9901		



Mating face

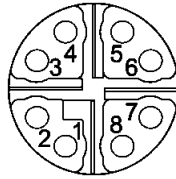

X-coding
Mating face
acc. to IEC 61076-2-109



Identification

Part number

Drawing

Dimensions in mm

**har-speed M12
Adapter M12-RJ45**



straight, Cat. 6A

Panel thickness
min. 2.1 mm
max. 4.5 mm

21 03 381 2800

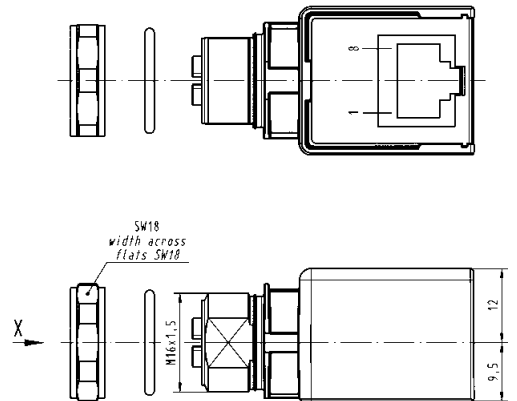
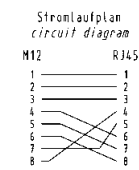
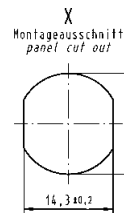
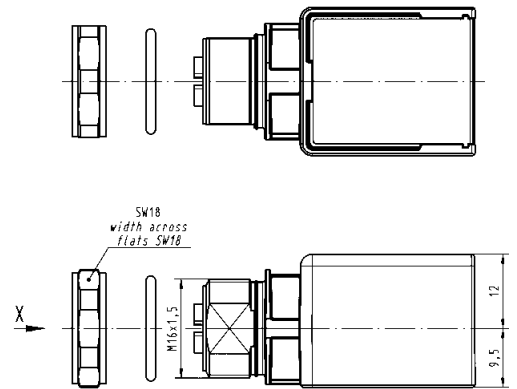
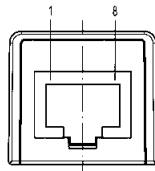
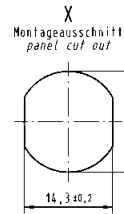

angled, Cat. 6A

Panel thickness
min. 2.1 mm
max. 4.5 mm

21 03 381 4800



Mating face

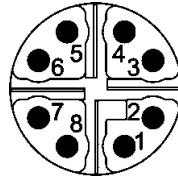

X-coding
Mating face
acc. to IEC 61076-2-109



Circular Connectors

Identification Part number Drawing Dimensions in mm

M12 Gender changer, Cat. 6A



21 03 381 6815

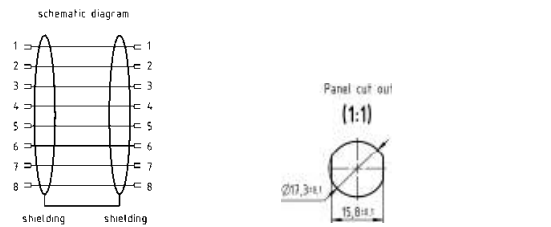
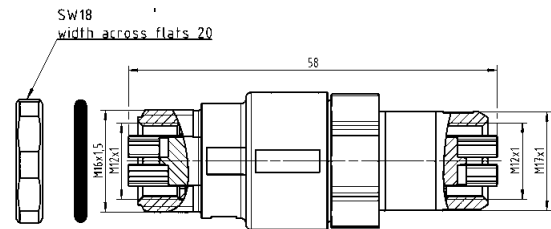

M12 Gender changer, Cat. 5
Female-Female
4 poles, D-coding
8 poles, X-coding

21 03 381 6402

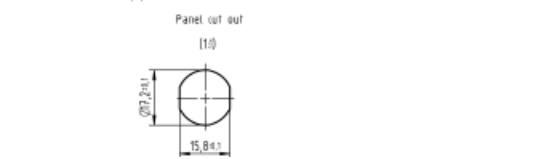
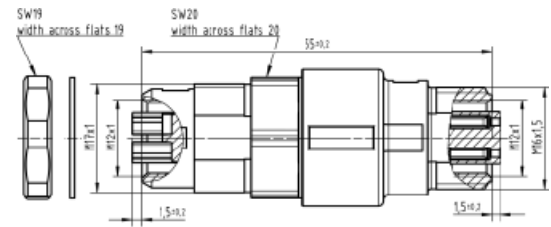

Wall bracket



21 01 000 0036

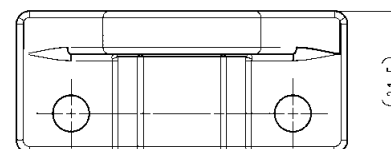
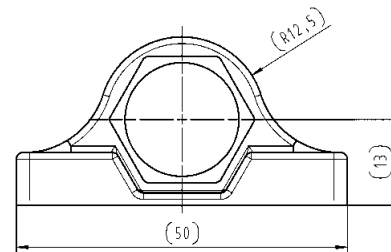



Mating face

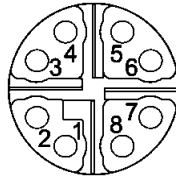

X-coding
Mating face
acc. to IEC 61076-2-109



Circular Connectors

Identification	Part number	Drawing	Dimensions in mm
<p>har-speed M12 PCB adapter Female, X-coding, straight, Cat. 6_A for front mounting</p> <p>Packaging: 60 pieces incl. housing</p> <p>Packaging: 1 piece incl. housing</p>	<p>21 03 381 2802</p> <p>21 03 381 2813</p>		
<p>har-speed M12 PCB adapter Female, X-coding, straight, Cat. 5 for front mounting</p> <p>Packaging: 60 pieces incl. housing</p> <p>Packaging: 1 piece incl. housing</p>	<p>21 03 381 2803</p> <p>21 03 381 2814</p>		
<p>har-speed M12 PCB adapter Female, X-coding, angled, Cat. 6_A for front mounting</p> <p>Packaging: 30 pieces incl. housing</p> <p>Packaging: 1 piece incl. housing</p>	<p>21 03 381 4802</p> <p>21 03 381 4810</p>		



Mating face

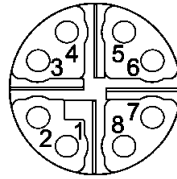

X-coding
Mating face
acc. to IEC 61076-2-109



Identification	Part number	Drawing	Dimensions in mm
<p>har-speed M12 PCB adapter Female, X-coding, straight, Cat. 6_A for rear mounting</p> <p>Packaging: 60 pieces incl. housing</p> <p>Packaging: 1 piece incl. housing</p>	<p>21 03 381 2804</p> <p>21 03 381 2811</p>		
<p>har-speed M12 PCB adapter Female, X-coding, straight, Cat. 5 for rear mounting</p> <p>Packaging: 60 pieces incl. housing</p> <p>Packaging: 1 piece incl. housing</p> <p>Packaging: 60 piece incl. housing</p>	<p>21 03 381 2805</p> <p>21 03 381 2812</p> <p>21 03 381 2809</p>		
<p>har-speed M12 PCB adapter Female, X-coding, angled, Cat. 6_A for rear mounting</p> <p>Packaging: 30 pieces incl. housing</p> <p>Packaging: 1 piece incl. housing</p>	<p>21 03 381 4804</p> <p>21 03 381 4809</p>		



Mating face

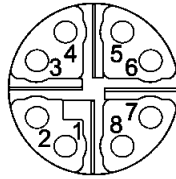

X-coding
Mating face
acc. to IEC 61076-2-109



Circular Connectors

Identification Part number Drawing Dimensions in mm

har-speed M12
PCB adapter

Packaging: 60 pieces in a tray
Order housing
separately

Female
8 poles, X-coding
Cat. 6A

Female
8 poles, X-coding
Cat. 5

21 03 381 2806

21 03 381 2807

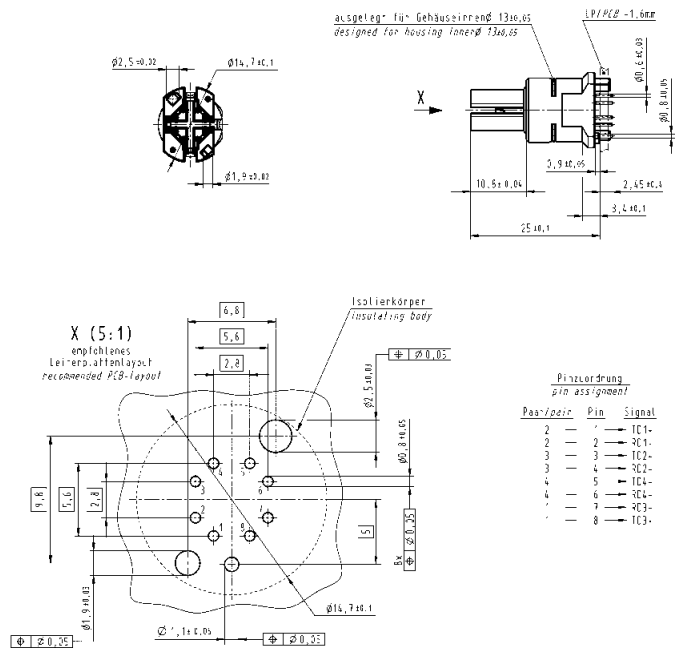

Housing



Packaging: 10 pieces in a tube

for rear mounting







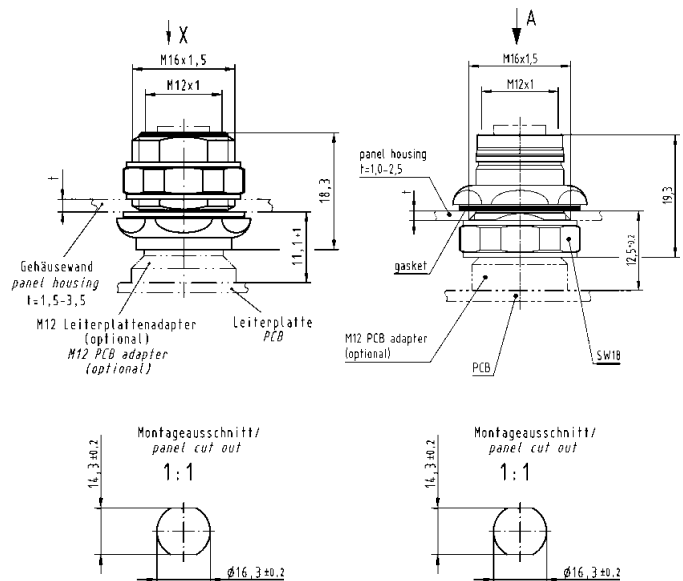

for front mounting

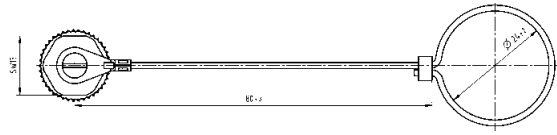
21 03 301 2000

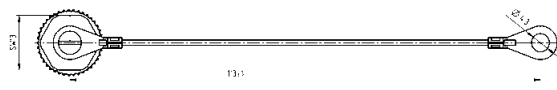
21 03 301 2003

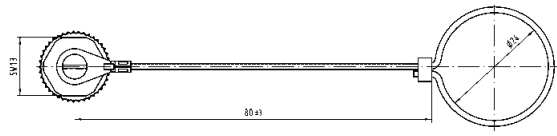

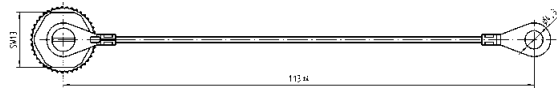
Identification	Part number	Drawing																	
Crimping tool for <i>har-speed</i> M12	09 99 000 0501																		
Accessories <i>har-speed</i> M12 Locator Single contacts (500 mating cycles) <i>har-speed</i> M12 contacts AWG 28-24 / 0.08-0.22 mm ² <i>har-speed</i> M12 contacts AWG 26-23 / 0.13-0.25 mm ²	09 99 000 0525 21 01 100 9014 21 01 100 9019	<i>har-speed</i> contacts <table border="1"> <thead> <tr> <th>Part number</th> <th>AWG</th> <th>Tool settings</th> </tr> </thead> <tbody> <tr> <td rowspan="3">21 01 100 9014</td> <td>28</td> <td>3</td> </tr> <tr> <td>26</td> <td>4</td> </tr> <tr> <td>24</td> <td>5</td> </tr> <tr> <td rowspan="3">21 01 100 9019</td> <td>26</td> <td>4</td> </tr> <tr> <td>24</td> <td>5</td> </tr> <tr> <td>23</td> <td>5</td> </tr> </tbody> </table>	Part number	AWG	Tool settings	21 01 100 9014	28	3	26	4	24	5	21 01 100 9019	26	4	24	5	23	5
Part number	AWG	Tool settings																	
21 01 100 9014	28	3																	
	26	4																	
	24	5																	
21 01 100 9019	26	4																	
	24	5																	
	23	5																	
Accessories M12 Lock nut	21 01 000 0018																		
M12 dynamometric screwdriver Tightening torque 0.6 Nm for M12 Slim design SW 15	09 99 000 0646																		

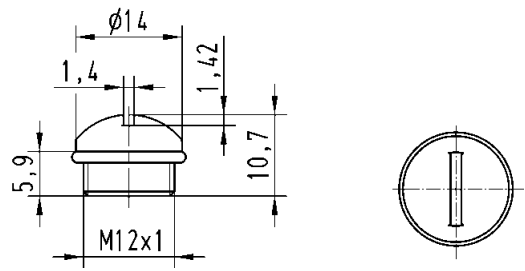
Identification	Part number	Drawing	Dimensions in mm
<p>Cap metal M12 for IP65 / 67 M12 metal cap for male side with cord</p> 	21 01 000 0033		
<p>Cap metal M12 for IP65 / 67 M12 metal cap for male side with cable clip</p> 	21 01 000 0038		
<p>Cap metal M12 for IP65 / 67 M12 metal cap for female side with cord</p> 	21 01 000 0030		
<p>Cap metal M12 for IP65 / 67 M12 metal cap for female side with cable clip</p> 	21 01 000 0031		
<p>Cap M12 for IP65 / 67 Seals material Viton Plastic cap for female</p> 	21 01 000 0003		

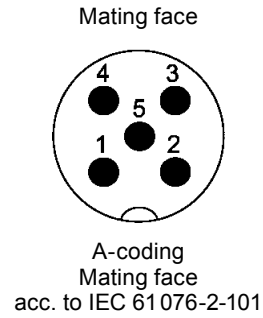
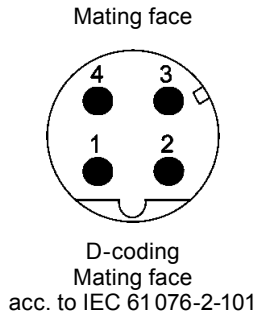

Applications / Advantages

- M12 PushPull for a fast and vibration-free connection
- Simple assembly without tools
- You can hear it click into place
- Suitable for signal and data transmission

Identification	Part number	Drawing	Dimensions in mm
<p>M12 PushPull Slim design</p> <p>Male straight version 4 poles, D-coding, IP54 Cable diameter: 5.7 - 8.8 mm</p>	21 03 881 1430		
<p>M12 PushPull Slim design</p> <p>Male straight version 5 poles, A-coding, IP54 Cable diameter: 5.7 - 8.8 mm</p>	21 03 821 1530		

M12 PushPull Connector

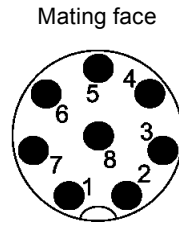

A-coding
Mating face
acc. to IEC 61076-2-101

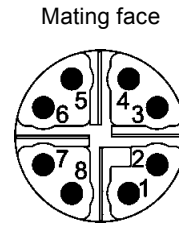

X-coding
Mating face
acc. to IEC 61076-2-119



Circular Connectors

Identification Part number Drawing Dimensions in mm

M12 PushPull Slim design



Male
straight version
8 poles, A-coding, IP54
Cable diameter: 5.7 - 8.8 mm

21 03 821 1830

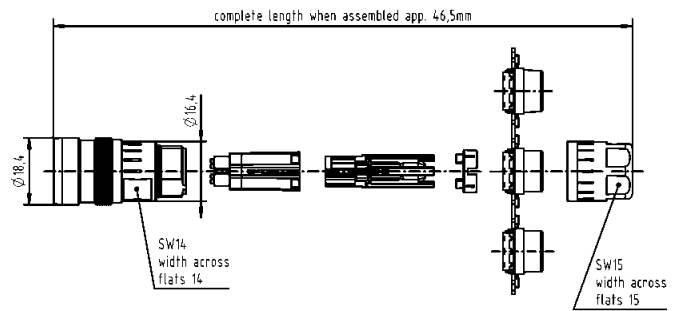

M12 PushPull Slim design



Male
straight version
8 poles, X-coding, IP54
Cable diameter: 5.7 - 8.8 mm

21 03 881 1830

M12 PushPull adapter

21 03 381 2403

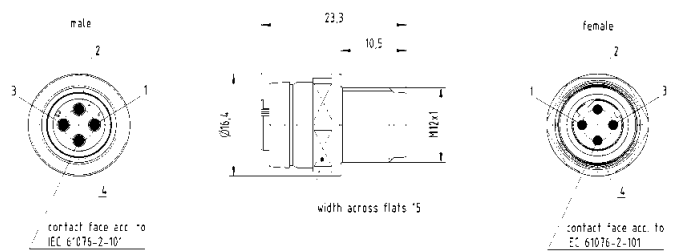

The adapter can be used to bring a PushPull feature on a standard receptacle housing without PushPull feature.

M12 PushPull PCB connector



Circular Connectors



Mating face

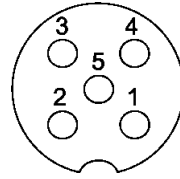

A-coding
Mating face
acc. to IEC 61076-2-101



Identification

Part number

Drawing

Dimensions in mm

M12 PCB adapter, shielded



Packaging: 60 pieces in a tray
Order housing separately

Female
5 poles, A-coding

8 poles, A-coding

21 03 321 2518*

21 03 321 2818*

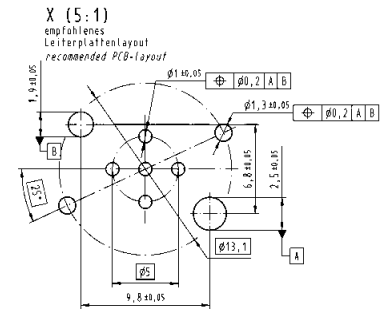
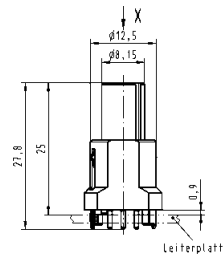

Housing for PushPull locking



for front mounting

21 03 301 2003

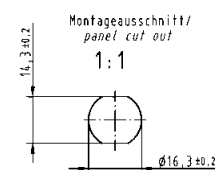
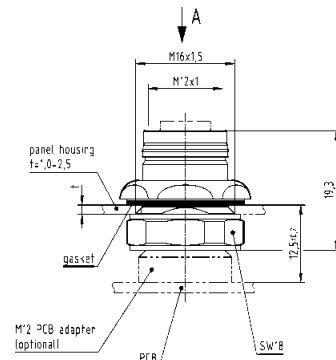

M12 PushPull PCB connector



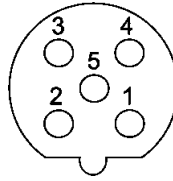

Mating face



B-coding
Mating face
acc. to IEC 61076-2-101

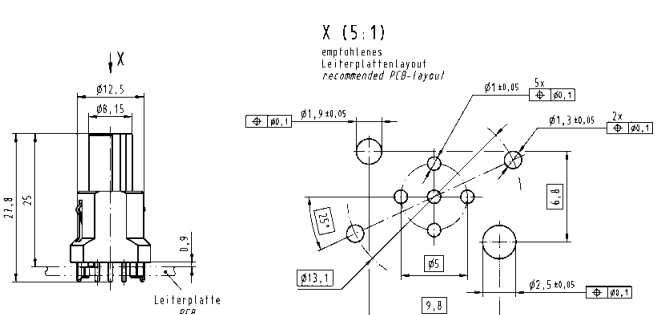

Circular
Connectors

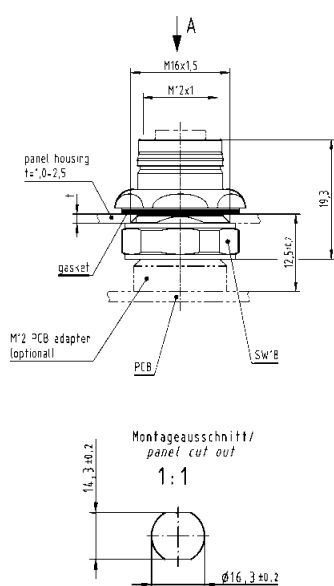
Identification	Part number	Drawing	Dimensions in mm
<p>M12 PCB adapter, shielded</p>  <p>Packaging: 60 pieces in a tray Order housing separately</p> <p>Female 5 poles, B-coding</p>	<p>21 03 341 2518*</p>	 <p>X (5:1) empfohlenes LeiterplattenLayout recommended PCB-layout</p>	
<p>Housing for PushPull locking</p>  <p>for front mounting</p>	<p>21 03 301 2003</p>	 <p>panel housing t±0-2,5</p> <p>gasket</p> <p>M12 PCB adapter (optional)</p> <p>PCB</p> <p>SW"B</p> <p>Montageausschnitt/ panel cut out 1:1</p>	



Mating face

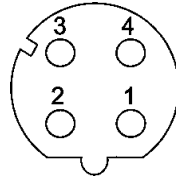

D-coding
Mating face
acc. to IEC 61076-2-101



Circular Connectors

Identification	Part number	Drawing	Dimensions in mm
----------------	-------------	---------	------------------

M12 PCB adapter, shielded



Packaging: 60 pieces in a tray
Order housing separately

Female
4 poles, D-coding

21 03 381 2418*

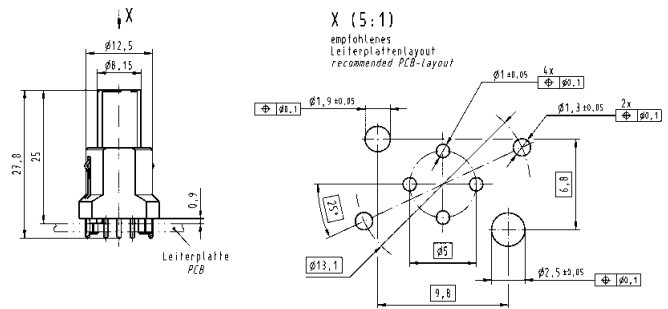

Housing for PushPull locking



for front mounting

21 03 301 2003

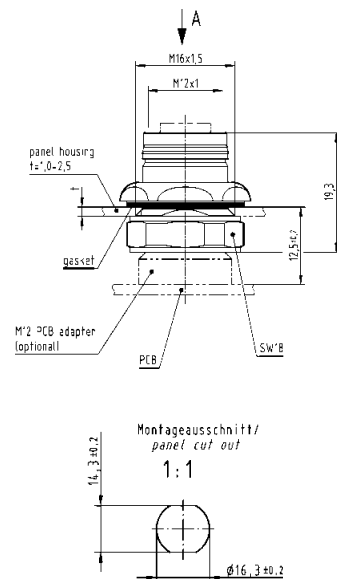

M12 PushPull PCB connector



Mating face

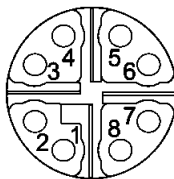

X-coding
Mating face
acc. to IEC 61076-2-101



Circular Connectors

Identification

Part number

Drawing

Dimensions in mm

**har-speed M12
PCB adapter**



**Packaging: 60 pieces in a tray
Order housing
separately**

Female
8 poles, X-coding
Cat. 6A

Female
8 poles, X-coding
Cat. 5

21 03 381 2806

21 03 381 2807

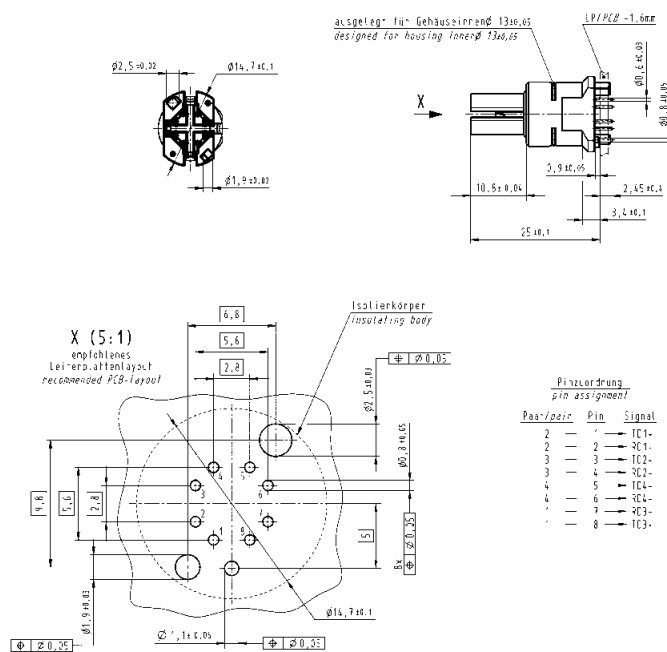

**Housing
for PushPull locking**



for front mounting

21 03 301 2003

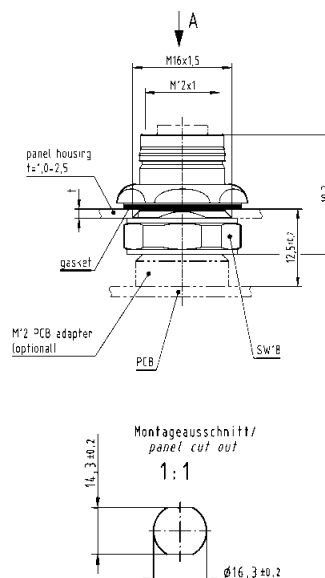

Identification	Part number	Drawing
Crimping tool for M12 PushPull	09 99 000 0501	

Identification	Part number	Drawing																	
Accessories M12 PushPull Locator for D-Sub contacts for contact 21 01 100 9020 for <i>har</i> -speed contacts	09 99 000 0531 61 03 600 0023 09 99 000 0525	 																	
D-Sub single contacts (500 mating cycles)		D-Sub contacts																	
turned male contacts AWG 22 - 18 / 0.33 - 0.82 mm ² AWG 24 - 20 / 0.25 - 0.52 mm ² AWG 26 - 22 / 0.13 - 0.33 mm ² AWG 28 - 24 / 0.09 - 0.25 mm ²	09 67 000 3576 09 67 000 8576 09 67 000 5576 09 67 000 7576	<table border="1"> <thead> <tr> <th>Part number</th> <th>AWG</th> <th>Tool settings</th> </tr> </thead> <tbody> <tr> <td rowspan="3">09 67 000 3x76</td> <td>18</td> <td>6</td> </tr> <tr> <td>20</td> <td>6</td> </tr> <tr> <td>22</td> <td>5</td> </tr> <tr> <td>09 67 000 8x76</td> <td>20, 22, 24</td> <td>6</td> </tr> <tr> <td>09 67 000 5x76</td> <td>22, 24, 26</td> <td>6</td> </tr> </tbody> </table>	Part number	AWG	Tool settings	09 67 000 3x76	18	6	20	6	22	5	09 67 000 8x76	20, 22, 24	6	09 67 000 5x76	22, 24, 26	6	
Part number	AWG	Tool settings																	
09 67 000 3x76	18	6																	
	20	6																	
	22	5																	
09 67 000 8x76	20, 22, 24	6																	
09 67 000 5x76	22, 24, 26	6																	
turned male contact for 8 pole connector, A-coding, AWG 26 - 22	21 01 100 9020																		
Single contacts (500 mating cycles)		<i>har</i> -speed contacts																	
<i>har</i> -speed M12 contacts AWG 28-24 / 0.08-0.22 mm ²	21 01 100 9014	<table border="1"> <thead> <tr> <th>Part number</th> <th>AWG</th> <th>Tool settings</th> </tr> </thead> <tbody> <tr> <td rowspan="3">21 01 100 9014</td> <td>28</td> <td>3</td> </tr> <tr> <td>26</td> <td>4</td> </tr> <tr> <td>24</td> <td>5</td> </tr> <tr> <td rowspan="3">21 01 100 9019</td> <td>26</td> <td>4</td> </tr> <tr> <td>24</td> <td>5</td> </tr> <tr> <td>23</td> <td>5</td> </tr> </tbody> </table>	Part number	AWG	Tool settings	21 01 100 9014	28	3	26	4	24	5	21 01 100 9019	26	4	24	5	23	5
Part number	AWG	Tool settings																	
21 01 100 9014	28	3																	
	26	4																	
	24	5																	
21 01 100 9019	26	4																	
	24	5																	
	23	5																	
<i>har</i> -speed M12 contacts AWG 26-23 / 0.13-0.25 mm ²	21 01 100 9019	 <table border="1"> <thead> <tr> <th></th> <th>a</th> </tr> </thead> <tbody> <tr> <td>AWG 22 - 18</td> <td>1.34</td> </tr> <tr> <td>AWG 24 - 20</td> <td>1.13</td> </tr> <tr> <td>AWG 26 - 22</td> <td>0.88</td> </tr> </tbody> </table>		a	AWG 22 - 18	1.34	AWG 24 - 20	1.13	AWG 26 - 22	0.88									
	a																		
AWG 22 - 18	1.34																		
AWG 24 - 20	1.13																		
AWG 26 - 22	0.88																		

Identification

Part number

Drawing

M12
dynamometric screwdriver





Tightening torque 0.6 Nm

for M12 Slim design

SW 15

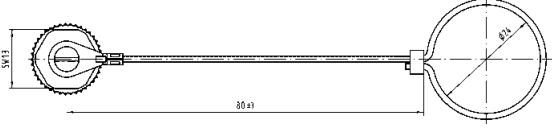
09 99 000 0646

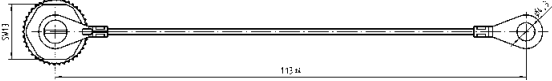

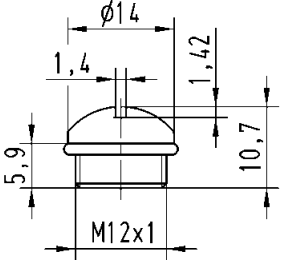
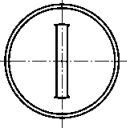
Identification	Part number	Drawing	Dimensions in mm
<p>Cap metal M12 for IP65 / IP67 M12 metal cap for female side with cord</p> 	<p>21 01 000 0030</p>		
<p>Cap metal M12 for IP65 / IP67 M12 metal cap for female side with cable clip</p> 	<p>21 01 000 0031</p>		
<p>Cap M12 for IP65 / IP67 Seals material Viton Plastic cap for female</p> 	<p>21 01 000 0003</p>		

Specifications IEC 60352-4
IEC 60068-2-52:1996, severity level 4



Technical characteristics M12 INOX

Type M12 INOX V4A	HARAX® M12-L 4 poles	M12 Crimp
-------------------	--------------------------------	-----------

General data

Conductor cross section	0.34 - 0.75 mm ² AWG 22 - 18	0.14 - 0.75 mm ² AWG 26 - 18
Diameter of individual strands	≥ 0.1 mm	X
Conductor insulation material	PVC	X
Conductor diameter	1.6 - 2.0 mm 2.0 - 2.6 mm	2.0 - 2.3 mm
Cable diameter	6 - 8 mm	4.5 - 8.8 mm
Temperature range	-40 °C ... +85 °C	-40 °C ... +85 °C
Temperature during connection	-5 °C ... +50 °C	-5 °C ... +50 °C
Degree of protection	IP65 / 67	IP65 / IP66 / IP67
Mating cycles	100	500
Tightening torque connector / hexagonal wrench	0.6 Nm / SW 17	0.6 Nm / SW 17

Electrical characteristics

Rated current	6 A	4 A
Rated voltage	50 V	250 V
Rated impulse voltage	1.5 kV	1.5 kV
Contact resistance	10 mΩ	10 mΩ
Insulation resistance	10 ⁸ Ω	10 ⁸ Ω
Pollution degree	3	3
Overvoltage category	3	3
Isolation group	1	1

Materials

Contact material	Brass	Brass
Contact plating	Gold	Gold
Contact carrier material	PA unreinforced	PA
Housing material	V4A	V4A

Technical characteristics M12 INOX

Current carrying capacity The current carrying capacity is limited by maximum temperature of materials for inserts and contacts including terminals. The current capacity-curve is valid for continuous, not interrupted current-loaded contacts of connectors when simultaneous power on all contacts is given, without exceeding the maximum temperature.

Control and test procedures according to DIN IEC 60512-5.

M12-L
4 poles

1 = Wire gauge 0.34 mm²
2 = Wire gauge 0.75 mm²

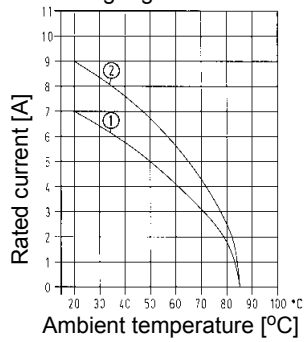

M12, Crimp 1 = Wire gauge 0.34 mm² /
0.5 mm²

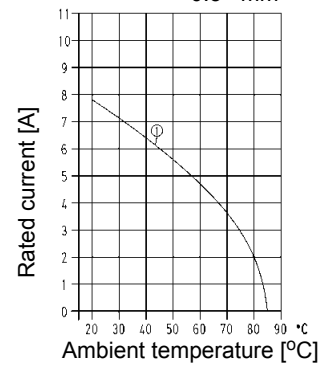

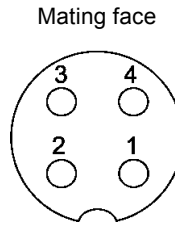

A-coding
Mating face
acc. to IEC 61076-2-101



Applications / Advantages

- Designed for rough outdoor applications in harsh environments
- Material V4A
- Available with crimp resp. *HARAX*® rapid termination
- Extreme robust design, quick assembly

Identification	Part number	Drawing	Dimensions in mm
<p><i>HARAX</i>® M12-L INOX</p>  <p>Female, A-coding, straight version 4 poles</p>	<p>21 03 222 2435</p>		



Mating face

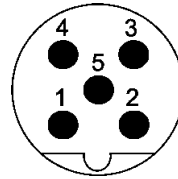

B-coding

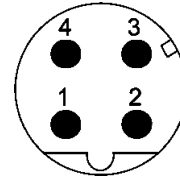

D-coding

Mating faces acc. to IEC 61076-2-101



Identification

Part number

Drawing

Dimensions in mm

M12-L Crimp INOX



Male, B-coding,
straight version
5 poles

21 03 841 1535

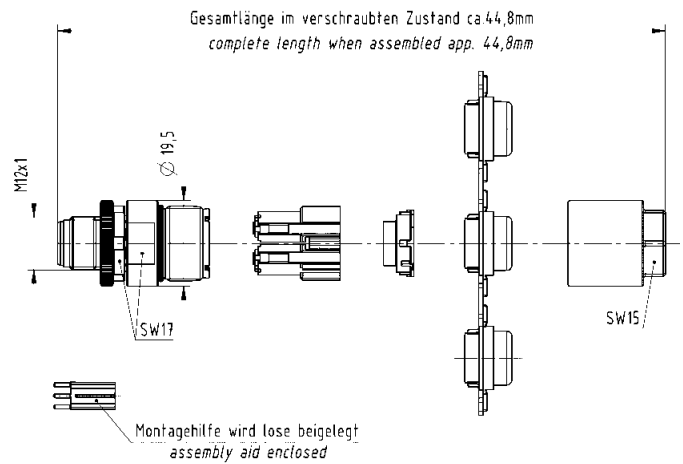

Male, D-coding,
straight version
4 poles

21 03 882 1435

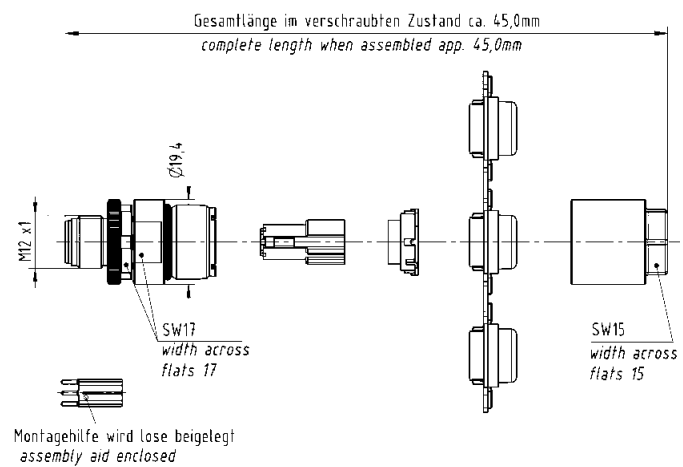

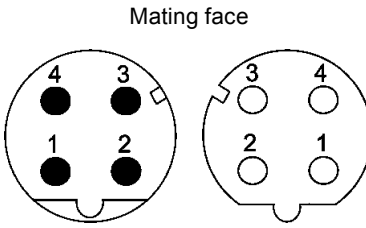

D-coding
Mating face
acc. to IEC 61076-2-101



Applications / Advantages

- M12 connector with the option to connect a plastic tube to protect the cable assembly in rough applications
- Robust design for IP65 / IP67 environments
- A- and D-coding available with crimp termination
- 360° shielding

Identification	Part number	Drawing	Dimensions in mm
<p>M12 connector with PMA connection for PVC tube NW10</p> <p>Male 4 poles, D-coding</p>	21 03 882 1411		
<p>M12 connector with PMA connection for PVC tube NW10</p> <p>Female 4 poles, D-coding</p>	21 03 882 2411		



Mating face

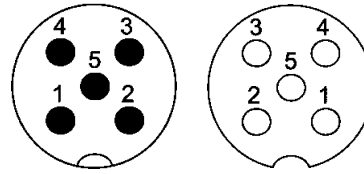

A-coding
Mating face
acc. to IEC 61076-2-101



Identification

Part number

Drawing

Dimensions in mm

M12 connector with PMA connection for PVC tube NW10

21 03 812 1511

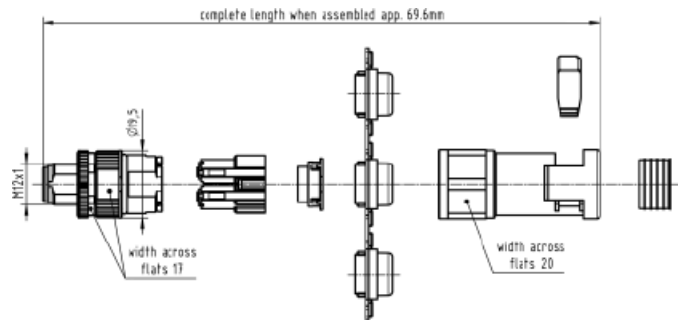

Male
5 poles, A-coding

M12 connector with PMA connection for PVC tube NW10

21 03 812 2511

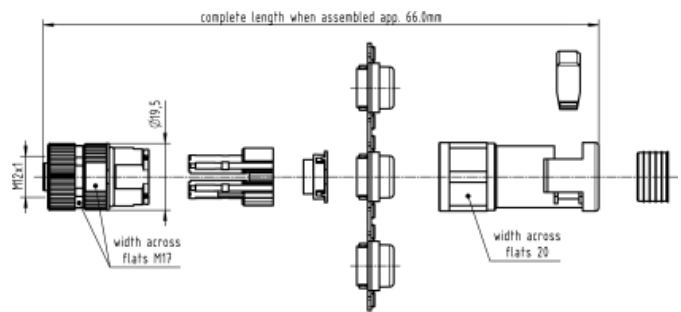

Female
5 poles, A-coding

Specifications IEC 60352-4
DIN 61984

Approval , VDE



Mating face

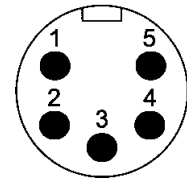

Technical characteristics 7/8" HARAX®

Type	7/8" HARAX®
------	-------------

General data

Conductor cross section	0.75 - 1.5 mm ² AWG 18-16
Diameter of individual strands	≥ 0.15 mm
Conductor insulation material	PVC, PP, TPE
Conductor diameter	≤ 2.8 mm
Cable diameter	6.8 - 9.5 mm (black) 9 - 12.5 mm (grey)
Temperature range	-40 °C ... +85 °C
Temperature during connection	-5 °C ... +50 °C
Degree of protection	IP65 / IP67
Mating cycles	100
Recommended tightening torque / Hexagonal wrench	1.5 Nm / SW 22

Electrical characteristics

Rated current	10 A
Rated voltage	230 V / 400 V
Rated impulse voltage	4.8 kV
Contact resistance	10 mΩ
Insulation resistance	10 ⁸ Ω
Pollution degree	3
Overvoltage category	3
Isolation group	1

Materials

Contact material	Copper alloy
Contact plating	Gold
Contact carrier material	TPU, PA
Housing material	TPU, zinc die-cast, PA

Technical characteristics 7/8" HARAX®

Current carrying capacity The current carrying capacity is limited by maximum temperature of materials for inserts and contacts including terminals. The current capacity-curve is valid for continuous, not interrupted current-loaded contacts of connectors when simultaneous power on all contacts is given, without exceeding the maximum temperature.

Control and test procedures according to DIN IEC 60512-5.

7/8"

1 = Wire gauge 0.75 mm² /
1.5 mm²

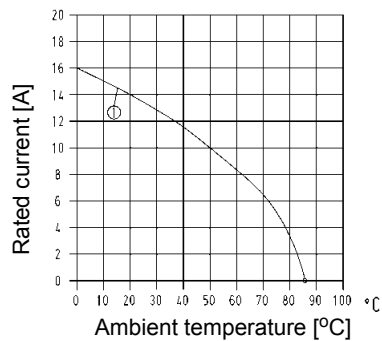



Mating face

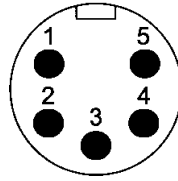

Applications / Advantages

- The reliable connector for power applications
- Patent HARAX® fast termination
- Overmoulded system cables in various lengths
- Robust design, quick assembly

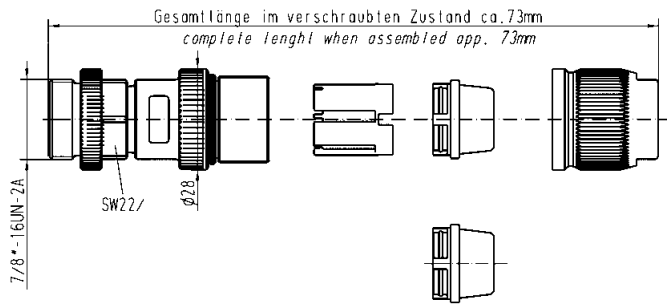
Identification	Part number	Drawing	Dimensions in mm
<p>7/8" HARAX® Male</p> 	<p>21 04 116 1505</p>		



Mating face

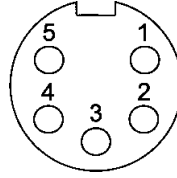

Identification

Part number

Drawing

Dimensions in mm

7/8" HARAX® Female

21 04 116 2505

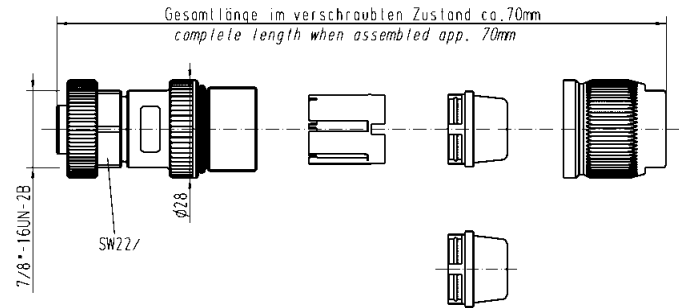



Male, 2 + PE



Male, 4 poles

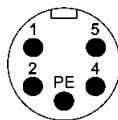

Male, 4 + PE

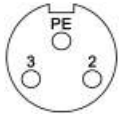

Female, 2 + PE



Female, 4 poles

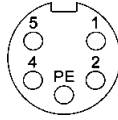

Female, 4 + PE



Technical characteristics

7/8" system cables

	3 poles (2+PE)		4 poles		5 poles (4+PE)	
	PVC	PUR	PVC	PUR	PVC	PUR
Rated voltage	max. 300 V AC/DC	max. 300 V AC/DC	max. 300 V AC/DC	max. 300 V AC/DC	max. 300 V AC/DC	max. 300 V AC/DC
Rated current / contact	max. 10 A at +40 °C	max. 10 A at +40 °C	max. 10 A at +40 °C	max. 10 A at +40 °C	max. 10 A at +40 °C	max. 10 A at +40 °C
Screw locking	7/8", self securing	7/8", self securing	7/8", self securing	7/8", self securing	7/8", self securing	7/8", self securing
Temperature range (working and storage)	-30 °C ... +80 °C	-30 °C ... +80 °C	-30 °C ... +80 °C	-30 °C ... +80 °C	-30 °C ... +80 °C	-30 °C ... +80 °C
Degree of protection	IP67	IP67	IP67	IP67	IP67	IP67
Number of wires / wire gauge	3 x 1.5 mm ²	3 x 1.5 mm ²	4 x 1.5 mm ²	4 x 1.5 mm ²	5 x 1.5 mm ²	5 x 1.5 mm ²
Conductor insulation	PVC (bn, bu, gn/ye)	PP (bn, bu, gn/ye)	PVC (bn, wh, bu, bk)	PP (bn, wh, bu, bk)	PVC (bu, bk, wh, bn, gn/ye)	PP (bu, bk, wh, bn, gn/ye)
Arrangement of insulated strands	84 x Ø 0.15 mm	84 x Ø 0.15 mm	84 x Ø 0.15 mm	84 x Ø 0.15 mm	84 x Ø 0.15 mm	84 x Ø 0.15 mm
Sheath	PVC	PUR (UL, CSA)	PVC	PUR (UL, CSA)	PVC	PUR (UL, CSA)
Sheath colour	grey	black	grey	black	grey	black
Outer diameter	Ø 7.0 ± 0.2 mm	Ø 7.0 ± 0.2 mm	Ø 7.8 ± 0.2 mm	Ø 7.1 ± 0.2 mm	Ø 8.5 ± 0.2 mm	Ø 7.8 ± 0.2 mm
Useable as trailing cable	no	yes	no	yes	no	yes
Halogen free acc. to	–	DIN VDE 0472 part 815	–	DIN VDE 0472 part 815	–	DIN VDE 0472 part 815
Flame retardant acc. to	DIN EN 60332-1-2	DIN EN 60332-1-2	DIN EN 60332-1-2	cUL20549	DIN EN 60332-1-2	cUL20549
Oil-resistant	IEC 60811-2-1	DIN EN 60811-2-1	–	–	–	–
	<p>Loading-Plan: PE green-yellow 2 brown 3 blue</p>	<p>Loading-Plan: 1 brown 2 white 3 blue 4 black</p>	<p>Loading-Plan: 1 black 2 blue PE green-yellow 4 brown 5 white</p>			

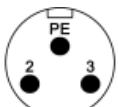

Male, 2 + PE

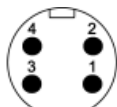

Male, 4 poles

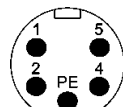

Male, 4 + PE

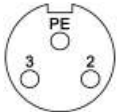

Female, 2 + PE

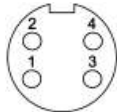

Female, 4 poles

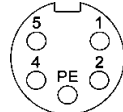

Female, 4 + PE



Part number definition



- Connector 1**
- 96 Male straight
 - 97 Female straight
 - 98 Male angled
 - 99 Female angled

- Connector 2**
- 00 No connector
 - 96 Male straight
 - 97 Female straight
 - 98 Male angled
 - 99 Female angled

- Number of contacts**
- 3 2 + PE
 - 4 4 poles
 - 5 4 + PE

- Cable material**
- 93 PVC (2 + PE)
 - 94 PUR (2 + PE)
 - 95 PVC (4 poles)
 - 96 PUR (4 poles)
 - 97 PVC (4 + PE)
 - 98 PUR (4 + PE)

- Preferred length***
- 005 0.5 m
 - 010 1.0 m
 - 015 1.5 m
 - 020 2.0 m
 - 050 5.0 m
 - 075 7.5 m
 - 100 10.0 m

* Other length on request



Mating face

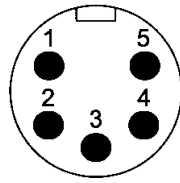

Identification	Part number	Drawing	Dimensions in mm
7/8" Panel feed-through 20 cm conductors, AWG 18, 1 mm ² , 3 poles Male	21 04 316 1305		
Female	21 04 316 2301		
7/8" Panel feed-through 50 cm conductors, AWG 18, 1 mm ² , 4 poles Female	21 04 316 2401		
7/8" Panel feed-through 50 cm conductors, AWG 18, 1 mm ² , 5 poles Male	21 04 316 1505		
Female	21 04 316 2501		

7/8" Panel feed-through



Mating face

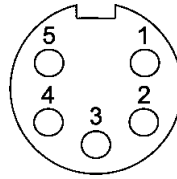

Circular Connectors

Identification	Part number	Drawing	Dimensions in mm
<p>7/8" Panel feed-through 20 cm conductors, AWG 18, 1 mm², 4 poles</p> <p style="text-align: right;">Female</p>	<p>21 04 316 2400</p>		
<p>7/8" Panel feed-through 50 cm conductors, AWG 18, 1 mm², 5 poles</p> <p style="text-align: right;">Female</p>	<p>21 04 316 2505</p>		

Identification	Part number	Drawing	Dimensions in mm
<p>Lock nut Pg 13.5 nickel plated</p> 	<p>21 01 000 0020</p>		
<p>7/8" dynamometric screwdriver Tightening torque 1.5 Nm</p> <p>for 7/8" SW 23</p>	<p>09 99 000 0395</p>		

Lock nut Pg 13.5
nickel plated



21 01 000 0020

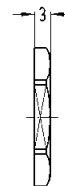
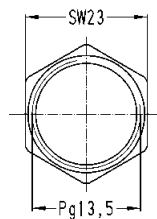

7/8"
dynamometric screwdriver
Tightening torque 1.5 Nm

for 7/8" SW 23

09 99 000 0395



Specifications IEC 60352-4
DIN 61984

Approval , VDE



Technical characteristics Panel feed-through

Type	HARAX® Pg 13.5/M20 Panel feed-through
-------------	--

General data

Conductor cross section	0.75 - 1.5 mm ² AWG 18 - 16
Diameter of individual strands	≥ 0.2 mm
Conductor insulation material	PVC, PP, TPE
Conductor diameter	≤ 2.8 mm
Cable diameter	6 - 9 mm
Temperature range	-25 °C ... +85 °C
Temperature during connection	-5 °C ... +50 °C
Degree of protection	IP67
Mating cycles	100
Recommended tightening torque	8 Nm

Electrical characteristics

Rated current	16 A
Rated voltage	230 V / 400 V
Rated impulse voltage	4 kV
Contact resistance	10 mΩ
Insulation resistance	10 ⁸ Ω
Pollution degree	3
Overvoltage category	3
Isolation group	1

Materials

Contact material	Copper alloy
Contact plating	Gold
Contact carrier material	TPU, PA
Housing material	TPU, PA

Technical characteristics Panel feed-through

Current carrying capacity The current carrying capacity is limited by maximum temperature of materials for inserts and contacts including terminals. The current capacity-curve is valid for continuous, not interrupted current-loaded contacts of connectors when simultaneous power on all contacts is given, without exceeding the maximum temperature.

Control and test procedures according to DIN IEC 60512-5.

Pg 13.5
3 poles

1 = Wire gauge
0.75 mm²

2 = Wire gauge
1.5 mm²

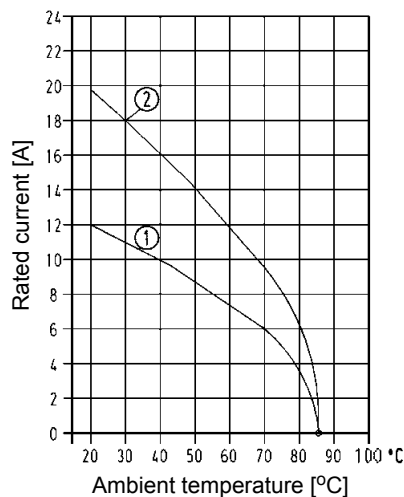

Pg 13.5 / M20
4 poles

1 = Wire gauge
0.75 mm²

2 = Wire gauge
1.5 mm²

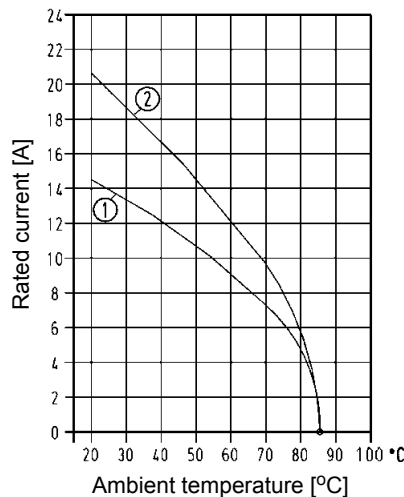

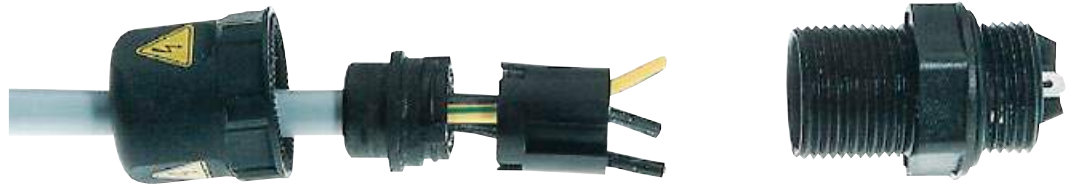

Identification	Part number	Drawing	Dimensions in mm
HARAX® Pg 13.5 / 3 contacts with faston blades	21 01 130 1013		<p>Gesamtlänge im verschraubten Zustand ca. 49,6mm Complete length when assembled app. 49,6mm</p> <p>14,5</p> <p>Pg 13,5</p>
HARAX® Pg 13.5 / 3 contacts with solder termination	21 01 130 1023		
HARAX® Pg 13.5 / 3 contacts with pre-assembled pigtail cable, l = 500 mm, 1.5 mm ²	21 01 130 1223		
HARAX® Pg 13.5 / 2 + PE with faston blades	21 01 130 3013		<p>Gesamtlänge im verschraubten Zustand ca. 49,6mm Complete length when assembled app. 49,6mm</p> <p>14,5</p> <p>Pg 13,5</p>
HARAX® Pg 13.5 / 2 + PE with solder termination	21 01 130 3023		
HARAX® Pg 13.5 / 2 + PE with pre-assembled pigtail cable, l = 500 mm, 1.5 mm ²	21 01 130 3233		
HARAX® Pg 13.5 / 4 contacts with solder termination	21 01 140 1023		<p>Gesamtlänge im verschraubten Zustand ca. 48,2mm Complete length when assembled app. 48,2mm</p> <p>12,9</p> <p>Pg 13,5</p>
HARAX® Pg 13.5 / 3 + PE with solder termination	21 01 140 3023		
HARAX® Pg 13.5 / 4 contacts with pre-assembled pigtail cable, l = 500 mm, 1.5 mm ²	21 01 140 1323		
HARAX® Pg 13.5 / 3 + PE with pre-assembled pigtail cable, l = 500 mm, 1.5 mm ²	21 01 140 3333		
HARAX® M20 / 4 contacts with solder termination	21 01 141 1023		<p>Gesamtlänge im verschraubten Zustand ca. 48,2mm Complete length when assembled app. 48,2mm</p> <p>12,9</p> <p>M20x1,5</p>
HARAX® M20 / 3 + PE with solder termination	21 01 141 3023		
HARAX® M20 / 4 contacts with pre-assembled pigtail cable, l = 500 mm, 1.5 mm ²	21 01 141 1323		
HARAX® M20 / 3 + PE with pre-assembled pigtail cable, l = 500 mm, 1.5 mm ²	21 01 141 3333		

Identification	Part number	Drawing	Dimensions in mm
<p>Termination element M12 HARAX® Pg 9 3 contacts</p> <p>Screw cap, splice ring, seal</p>	<p>21 01 010 0001</p>		
<p>Termination element M12 HARAX® Pg 9 4 contacts</p> <p>Screw cap, splice ring, seal</p>	<p>21 01 010 0006</p>		
<p>Lock nut Pg 9</p> <p>Lock nut Pg 13.5, SW 27</p> <p>Lock nut Pg 13.5, SW 24</p>	<p>21 01 000 0008</p> <p>21 01 000 0007</p> <p>21 01 000 0039</p>		

Advantages

- IP65 / IP67 RJ45 connector with toggle locking acc. to IEC 61 076-3-106 variant 1
- Robust zinc die cast housing, nickel plated
- Vibration and shock resistant
- Min. 500 mating cycles
- Shielded and unshielded versions
- Suitable for PoE (IEEE 802.3af) and PoE+ (IEEE 802.3at)
- ODVA approval

Technical characteristics device side

Han-Max®	
Connector type	RJ45 acc. to IEC 60 603-7
Number of contacts	8
Transmission performance	Category 5 / class D up to 100 MHz acc. to ISO/IEC 11801:2002; EN 50173-1
Transmission rate	10/100/1.000 Mbit/s
Shielding	unshielded / shielded
Mounting	field-assembly
Termination	with IDC contacts
Connectable cables	
- Conductor cross section	AWG 22 ... AWG 24 solid / stranded
Temperature range	-25 °C ... +70 °C

Technical characteristics cable side

	Han-Max®	Han-Max® RJ Industrial	Han-Max® RJ Industrial 10G
Connector type	RJ45 acc. to IEC 60 603-7	RJ45 acc. to IEC 60 603-7	RJ45 acc. to IEC 60 603-7
Number of contacts	8	4	8
Transmission performance	Category 5 / class D up to 100 MHz acc. to ISO/IEC 11801:2002; EN 50173-1	Category 5 / class D up to 100 MHz acc. to ISO/IEC 11801:2002; EN 50173-1	Category 6 / class E _A up to 250 MHz acc. to ISO/IEC 11801:2002; EN 50173-1
Transmission rate	10/100/1.000 Mbit/s	10/100 Mbit/s	10/100 Mbit/s resp. 1/10 Gbit/s
Shielding	unshielded / shielded	fully shielded, 360° shielding contact	fully shielded, 360° shielding contact
Mounting	field-assembly	no tools needed, field-assembly	no tools needed, field-assembly
Termination	with piercing contacts	with IDC contacts	with IDC contacts
Connectable cables			
- Conductor cross section	AWG 26/7 ... AWG 24/7 stranded	AWG 24/7 ... AWG 22/7 stranded AWG 23/1 ... AWG 22/1 solid	AWG 27/7 ... AWG 22/7 stranded AWG 24/1 ... AWG 22/1 solid
- Conductor diameter	max. 1.0 mm (including insulation)	max. 1.6 mm (including insulation)	max. 1.6 mm (including insulation)
- Cable diameter	4 ... 8 mm	4 ... 8 mm	4 ... 8 mm
Temperature range	-25 °C ... +70 °C	-40 °C ... +70 °C	-40 °C ... +70 °C



Device side

Identification	Part number	Drawing	Dimensions in mm
----------------	-------------	---------	------------------

<p>Han-Max® RJ45 panel feed-through unshielded version (UTP)</p> 

<p>09 15 300 0301</p>

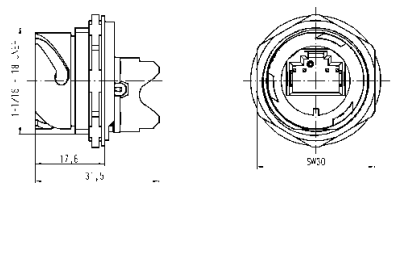

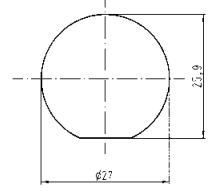
--

<p>Panel cut out for max. Panel thickness 2.3 mm</p> 
--

<p>Han-Max® MS RJ45 panel feed-through unshielded version (UTP)</p> 
--

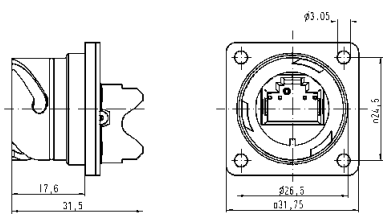
<p>09 15 300 0311</p>

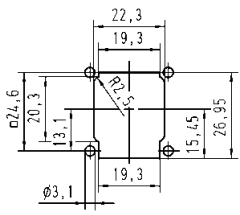
--

<p>panel feed through</p> 

<p>Han-Max® Protection cover Device side</p> 



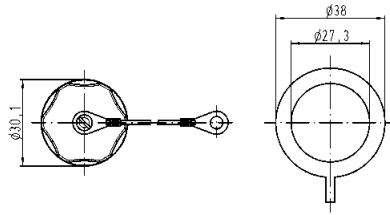

<p>09 15 300 5411</p>



--

--

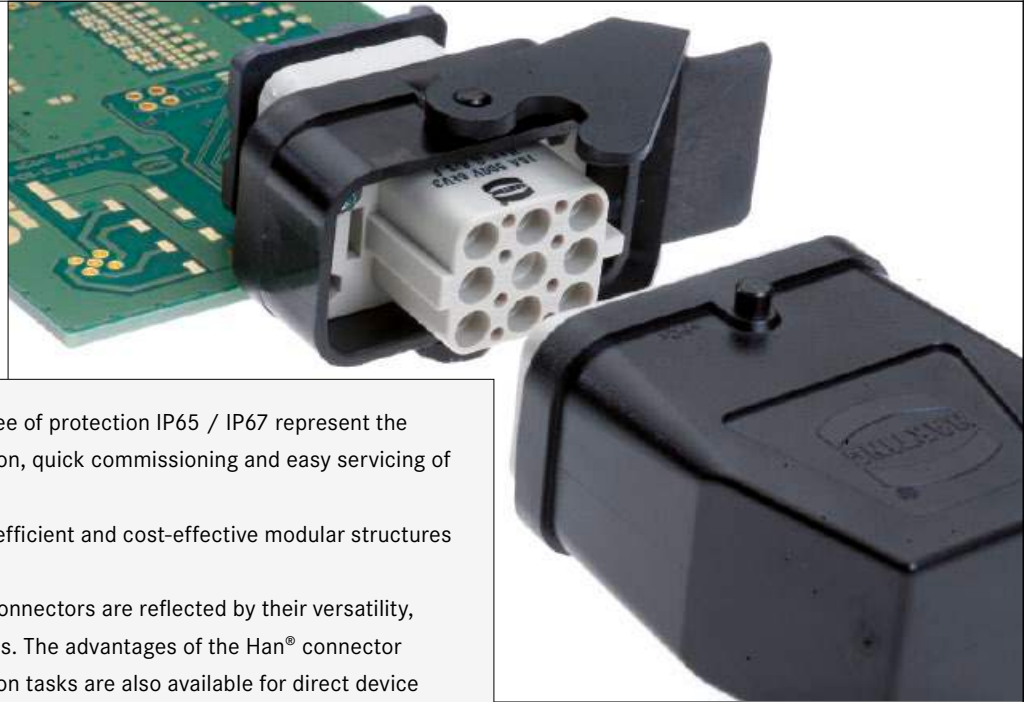

Cable side

Identification	Part number	Drawing	Dimensions in mm
<p>Han-Max® Connector Cat. 5, 8-poles, piercing termination</p> <p>unshielded version (UTP)</p>  <p>fully shielded version (STP)</p>	<p>09 15 300 0401</p> <p>09 15 300 0402</p>		
<p>Han-Max® RJ Industrial Connector Cat. 5, 4-poles, IDC termination</p> 	<p>09 15 300 0412</p>		
<p>Han-Max® RJ Industrial 10G Connector Cat. 6, 8-poles, IDC termination</p> 	<p>09 15 300 0431</p>		
<p>Han-Max® Protection cover Cable side</p> 	<p>09 15 300 5401</p>		



Han® industrial connectors with degree of protection IP65 / IP67 represent the worldwide standard for safe installation, quick commissioning and easy servicing of machines and plants.

The use of Han® connectors enables efficient and cost-effective modular structures of machines and plants.

The outstanding properties of Han® connectors are reflected by their versatility, application bandwidth and ruggedness. The advantages of the Han® connector family that users know from installation tasks are also available for direct device connections. The Han® connectors support the installation of automation systems in control cabinets and of IP65 / IP67 distributed devices using identical connectors. Key user benefits: Investment and operational security.

Application profile:

CONNECTION TYPE		ENVIRONMENT		APPLICATION						
Board to Board	Cable/Wire to Board	IP20	IP65 / IP67	Data	Signal	Power	high performance			
				Data transfer rate	Shielding	Number of contacts, contact density	Voltage, working current			
Cable termination			PCB termination			Application standard				
<i>Han-Quick Lock®</i>	<i>IDC</i>	<i>Crimp</i>	<i>THT</i>	<i>SMC</i>	<i>SMT</i>	 ECOFAST				
<i>Screw</i>	<i>Cage clamp</i>	<i>Axial screw</i>	<i>Press-in</i>	Housing integration						
<i>separate housing</i>	<i>integrated housing</i>									

Contents

	Page
Han® 3 A RJ45	04.04
Han® 3 A 2 x LC duplex	04.10
Han® 3 A RJ45 Hybrid (3 x Power)	04.11
Han® 3 A LC duplex Hybrid (3 x Power)	04.13
Han® 3 A RJ45 Hybrid (4 x Power)	04.15
Han-Brid®	04.20
Han® Q 5/0 with pcb adapter	04.30
Han® Q 7/0 with pcb adapter	04.32
Han® Q 4/2 with pcb adapter	04.36
Han® Q 8/0 with pcb adapter	04.38
Han DD® with pcb adapter	04.44
Han E® with pcb adapter	04.46
Han-Modular® with pcb adapter	04.48

Han® connectors with degree of protection IP65 / IP67 are established as the worldwide standard for industrial connectors. This standard connector can also be used directly as appliance connector.

The rugged housings are equipped with secure interlock mechanisms that protect the contact inserts from external negative influences such as dust, dampness and mechanical stress. On the appliance side, the connector contacts are routed in the bulkhead mount module, soldered directly onto the PCB and are aligned precisely to the bulkhead frame. This results in appliance connections that are resistant to any environmental stress.

The Han® appliance connectors offer comprehensive solutions based on connector inserts for data, signal and power lines up to 32 A per contact. The Han® 3 A housing can be equipped for

communication applications with copper-bound RJ45 modules, 4-pole (Cat. 5) and 8-pole (Cat. 6) and optical LC modules. The power contact inserts are available for the Han® 3 A, Han® Compact and Han® B housing variants. The cables can be wired to the contact inserts by way of crimp, screw or cage clamp terminals, or using the patented Quick-Lock® quick connection technology for on-site assembly.

HARTING highlights its Han® 3 A appliance connector series with versatile hybrid contact inserts for wiring data and power lines using a single connector and cable. This functionality results in a reduction of insertion points and cabling by more than 50%.

Han® connectors with high degree of protection can be used for wiring appliances, terminal boxes and control cabinets.



Han® APPLIANCE CONNECTORS:

The PCB-Adapter of HARTING can be used to convert Han® industrial connectors into fully-fledged PCB connectors. The modular PCB adapters enable the implementation of various Han® contact inserts.

The PCB Adapter concept:

- The PCB adapter is processed as component in a standard soldering process and is a fixed part of the PCB.
- The contact insert of the Han® industrial connector is simply plugged in after the soldering process has been completed.
- The bulkhead mount housing with the bracket interlock is mounted to the appliance housing.

This modularity guarantees the availability of a wide range of contact inserts and connector housings for the assembly of a multitude of rugged IP65 / IP67 appliance connectors for data, signal and power lines.

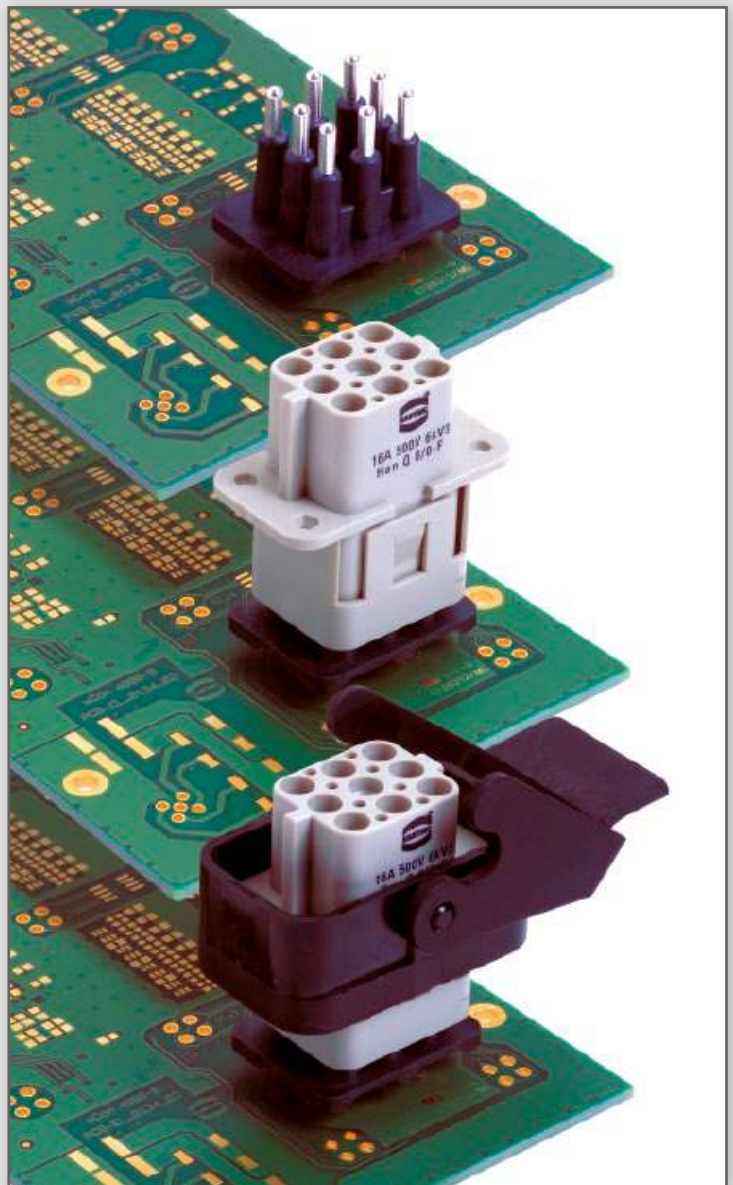

SCALABLE HYBRID APPLIANCE CONNECTION USING Han® CONNECTORS:

The hybrid appliance connector series enable the cost-effective combination of Fieldbus/Ethernet communication and power supply lines in a single cable and connector.

The contact insert combination for communication and for the power supply to the appliance is soldered directly to the PCB. The bulkhead mount housing can be adapted directly to the housing shape, or be mounted as separate unit to the appliance housing. HARTING offers cable solutions for smaller batches which can be used to connect the contact insert to the PCB.

Key user benefits: A tailored appliance connection is always available for small- and large-scale appliance series.





Han® 3 A RJ45 device side

Advantages

- Simple mounting
- RJ45 plug-compatible
- Different versions cover all applications
- Coding (4 variants) possible

Technical characteristics

Number of ports	2 / 1x Han® 3 A RJ45 (IP65 / IP67)
Copper / termination	1x RJ45 (IP20)
Transmission performance	Category 5 / Class D up to 100 MHz acc. to ISO/IEC 11801:2002, EN 50 173-1
Transmission rate	10/100/1000 Mbit/s
Shielding	fully shielded, 360° shielding contact
Mounting	screw-on type on steel plate walls
Degree of protection	IP65 / IP67
Mating cycles	min. 500
Temperature range	-40 °C ... +70 °C
Housing material	
Plastic version	Polycarbonate, black, UL 94 V0
Metal version	Zinc die-cast, powder coating, grey

Identification	Part number	Drawing	Dimensions in mm
Housing bulkhead mounting Plastic version, black Metal version Standard Metal version M with fixed cover and with seal Metal version Standard Metal version M	09 20 003 0327 09 20 003 0301 09 37 003 0301 09 20 003 0306 09 37 003 0306	<p>Dimensions valid for Metal version Standard</p>	
Adapter for fixing of RJ45 jack with fixing clip without fixing clip	09 45 515 0020 09 45 515 0022		
RJ45 jacks Cat. 5 Solder variant SMD, 90° angled Solder variant overmolded, 90° angled	09 45 551 1100 ¹⁾ 09 45 551 1110 ²⁾ 09 45 551 1102 ¹⁾		

¹⁾ Packaging: Blister à 120 pieces

²⁾ Packaging: Tape & Reel à 130 pieces



Han® 3 A RJ45-panel feed-throughs and couplings Cat. 5

Identification	Part number	Drawing	Dimensions in mm	
Panel feed-through set, 8-poles				
Plastic version, black	straight			
	angled			09 45 225 1100
Metal version Standard, grey	straight			09 45 225 1108
	straight, inner vertical jack			09 45 215 1100
	angled			09 45 215 1101
Metal version Standard, grey with self-closing protective cap	straight			09 45 215 1103
	angled			09 45 215 1108
Metal version M, black	straight			09 45 215 1102
	angled			09 45 215 1109
Coding pin set for 4 different codings	09 45 820 0000			Dimensions valid for plastic version, straight
Double coupling, 8-poles incl. installation frame metal				
Plastic version, black	09 45 225 1107		Dimensions valid for plastic version	
Metal version Standard, grey	09 45 215 1107			
Metal version M, black	09 45 215 1110			
Coding pin set for 4 different codings	09 45 820 0000			
Protection cover for panel feed-through IP65 / IP67 with seal				
Plastic version, black	09 20 003 5449		Dimensions valid for plastic version	
Metal version Standard, grey	09 20 003 5425			
Metal version M, black	09 37 003 5405			



Han® 3 A RJ45 10G Cat. 6 – panel feed-throughs

Advantages

- Compact and robust design
- 360° shielding
- Easy mounting
- Transmission category 6, performance class E_A, suitable for 1/10 Gigabit Ethernet
- RJ45 mating compatible
- Coding (4 variants) possible

Technical characteristics

Number of ports	2 / 1x Han® 3 A RJ45 (IP65 / IP67) 1x RJ45 (IP20)
Transmission performance	Category 6 / class E _A acc. to ISO/IEC 11801:2002, EN 50 173-1
Transmission rate	10/100 Mbit/s and 1/10 Gbit/s
Shielding	Fully shielded, 360° shielding contact
Mounting	Screwable to cover plates
Degree of protection	IP65 / IP67
Mating cycles	min. 500
Temperature range	-40 °C ... + 70 °C
Housing material	
Plastic version	Polycarbonate, black, UL 94 V0
Metal version	Zinc die-cast, powder-coated

Identification	Part number	Drawing	Dimensions in mm
Panel feed-through set, 8-poles Plastic version, black Metal version Standard, grey Metal version M, black Metal version Standard, grey, with self-closing protective cap	09 45 225 1560 09 45 215 1560 09 45 215 1561 09 45 215 1562		
Han® 3 A RJ45 10G insert Cat. 6 (for Han® 3 A housings)	09 45 200 1560		
Han® 3 A RJ45 HIFF adapter to mount HIFF inserts (e.g. HARTING RJ Industrial® 10G RJ45 bulkhead or Ha-VIS preLink® RJ45) in Han® 3 A housings	09 45 515 0024		



Han® 3 A connector RJ45, 4-poles, Cat. 5

Advantages

- RJ45 Ethernet-Data connector suitable for industry
- Tool-less field-assembly with HARAX® rapid termination in IDC technology
- Category of transmission Cat. 5
- Compact design and very robust housing
- Suitable for termination of solid and stranded cables
- Up to 10 x reconductable
- PROFINET compatible
- Min. 500 mating cycles

Technical characteristics

Connector type	Han® 3 A Connector RJ45 acc. to IEC 61076-3-106 variant 5
Number of contacts	4
Transmission performance	Category 5 / Class D up to 100 MHz acc. to ISO/IEC 11801:2002, EN 50 173-1
Transmission rate	10/100 Mbit/s
Shielding	fully shielded, 360° shielding contact
Cable termination	tool-less with IDC contacts
Conductor cross section	
stranded	AWG 24/7 - AWG 22/7
solid	AWG 23/1 - AWG 22/1
Conductor diameter	max. 1.6 mm
Cable outer diameter	6.5 mm – 9.5 mm
Degree of protection	IP65 / IP67
Temperature range	-40 °C ... +70 °C
Housing material	
Plastic version	Polycarbonate, UL 94 V0, black
Metal versions	
Standard	Zinc die-cast, powder coating grey
M-version	Zinc die-cast, powder coating black

Identification	Part number	Drawing	Dimensions in mm
Han® 3 A connector set RJ45, 4-poles incl. housing, cable gland and instruction manual			
Plastic version, black	straight angled		09 45 125 1100 09 45 125 1104
Metal version Standard, grey	straight angled		09 45 115 1100 09 45 115 1104
Metal version M, black	straight angled		09 45 115 1102 09 45 115 1106
Coding pin set			09 45 820 0000
			Dimensions valid for plastic version, straight



Han® 3 A connector set RJ45, 8-poles, Cat. 6_A

Advantages

- RJ45 Ethernet-Data connector suitable for industry
- Field-assembly with mounting tool
- Category of transmission Cat. 6_A
- Compact design and very robust housing
- Min. 500 mating cycles

Technical characteristics

Connector type	Han® 3 A Connector RJ45
Number of contacts	8
Transmission performance	Category 6 _A / Class E _A up to 500 MHz acc. to ISO/IEC 11801:2002, EN 50 173-1
Transmission rate	10/100 Mbit/s and 1/10 Gbit/s
Shielding	fully shielded, 360° shielding contact
Cable termination	with piercing contacts
Conductor cross section	AWG 28/7 - AWG 24/7, stranded
Conductor diameter	max. 1.05 mm
Cable outer diameter	6.5 mm – 9.5 mm
Degree of protection	IP65 / IP67
Temperature range	-40 °C ... +70 °C
Housing material	Polycarbonate, UL 94 V0, black
Plastic version	
Metal versions	
Standard	Zinc die-cast, powder coating grey
M-version	Zinc die-cast, powder coating black

Identification

Part number

Drawing

Dimensions in mm

Han® 3 A connector set RJ45,
8-poles, Cat. 6

incl. housing, cable gland
and instruction manual

Plastic version, black

09 45 125 1520

Metal version Standard, grey

09 45 115 1520

Metal version M, black

09 45 115 1522

Han® 3 A RJ45
connector insert
can be combined with Han® 3 A housing

09 45 100 1520

Coding pin set

09 45 820 0000

suitable assembly tool

09 45 800 0520

Mating face acc. to IEC 60603-7

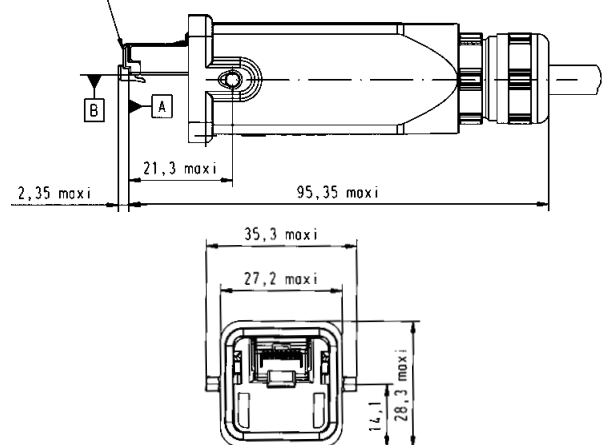

Dimensions valid for metal version Standard



Han® 3 A RJ45 10G connector, 8-poles, Cat. 6

Advantages

- RJ45 Ethernet-Data connector suitable for industry
- Tool-less field-assembly with *HARAX*® rapid termination in IDC technology
- Category of transmission Cat. 6
- Compact design and very robust housing
- Suitable for termination of solid and stranded cables
- PROFINET compatible
- Min. 500 mating cycles

Technical characteristics

Connector type	Han® 3 A Connector RJ45 acc. to IEC 61076-3-106 variant 5
Number of contacts	8
Transmission performance	Category 6 / Class E _A up to 500 MHz acc. to ISO/IEC 11801:2002, EN 50 173-1
Transmission rate	10/100 Mbit/s and 1/10 Gbit/s
Shielding	fully shielded, 360° shielding contact
Cable termination	tool-less with IDC contacts
Conductor cross section	
stranded	AWG 27/7 - AWG 22/7
solid	AWG 24/1 - AWG 22/1
Conductor diameter	max. 1.6 mm
Cable outer diameter	6.5 mm – 9.5 mm
Degree of protection	IP65 / IP67
Temperature range	-40 °C ... +70 °C
Housing material	
Plastic version	Polycarbonate, UL 94 V0, black
Metal versions	
Standard	Zinc die-cast, powder coating grey

Identification	Part number	Drawing	Dimensions in mm
Han® 3 A RJ45 connector, 8-poles incl. housing, cable gland and instruction manual			
Plastic version, black straight	09 45 125 1560		
Metal version Standard, grey straight	09 45 115 1560		
Han® 3 A RJ45 connector insert straight	09 45 100 1560		
can be combined with Han® 3 A housing			
Coding pin set	09 45 820 0000		

Dimensions valid for plastic version, straight



Han® 3 A 2 x LC duplex

Advantages

- Compact, space-saving Design
- Just one LWL modul for high mechanical load
- High packing density
- A & B parts identification according to TIA 568 standard

Technical characteristics

Degree of protection	IP65 / IP67
Temperature range	-40 °C ... +70 °C
Housing material	Zinc die-cast powder coating black

Identification	Part number	Drawing	Dimensions in mm
----------------	-------------	---------	------------------

Components device side

Multimode GOF
Singlemode GOF

09 57 467 0004 000
09 57 467 0005 000

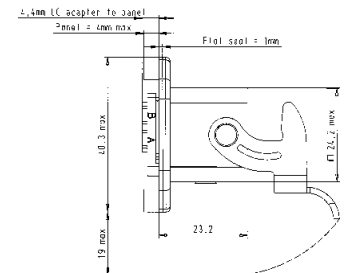
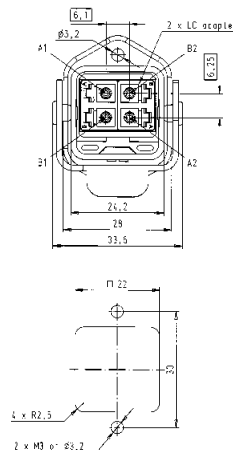

Connector

Multimode GOF
Singlemode GOF

09 57 407 0001 000
09 57 407 0002 000

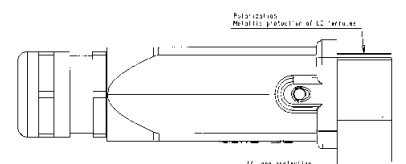
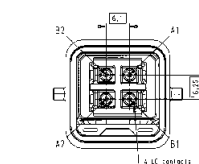



Han® 3 A RJ45 Hybrid

Advantages

- RJ45 Ethernet-Data connector suitable for industry with Power contacts for hybrid applications
- Field-assembly with mounting tool
- Category of transmission Cat. 5
- Compact design and very robust housing
- Suitable for termination with solid and stranded cables
- Protection against direct contact on cable and device side according to EN 60529

Reference note:

For cat. 6 patch cords it is recommended to use 1 connector with a white cable manager and one with a blue cable manager, in order to optimise the crosstalk between different signal pairs.

Technical characteristics

Degree of protection	IP65 / IP67
Mating interface	RJ45, 8-poles acc. to IEC 60603-7 plus 3x power
Temperature range	-40 °C ... +70 °C
Housing material	Zinc die-cast, powder coating black
Data	
Transmission performance	Category 5 / Class D up to 100 MHz acc. to ISO/IEC 11801:2002, EN 50173-1
Transmission rate	10/100/1000 Mbit/s
Shielding	fully shielded, 360° shielding contact
Cable diameter stranded	AWG 28/7 - AWG 24/7
Power	
Number of contacts	3 (AC: L1, PE, N / DC: V+, GND, V-)
Working voltage	300 V AC/DC
Working current	12 A @ 70 °C (see current carrying capacity Han D® contacts)
Cable diameter	2.5 mm ²

Identification	Part number	Drawing	Dimensions in mm
Components device side			
incl. 3x Han D® female contacts			
AC version	09 57 368 0500 000		
DC version	09 57 368 0501 000		
Cable side			
Connector incl. 3x Han D® male contacts			
AC version	09 57 308 0500 000		
DC version	09 57 308 0501 000		
suitable assembly tool	09 45 800 0520		



Hybrid cable assembly

Man

Identification	Part number	Drawing	Dimensions in mm
<p>Hybrid cable, double ended, 4 x 2 x AWG 26/7 + 3 x 2.5 mm²</p> <p>Length: 1 m AC version DC version</p> <p>Length: 5 m AC version DC version</p> <p>Length: 10 m AC version DC version</p> <p>Length: 20 m AC version DC version</p>	<p>33 57 211 0010 001 33 57 211 0010 002</p> <p>33 57 211 0050 001 33 57 211 0050 002</p> <p>33 57 211 0100 001 33 57 211 0100 002</p> <p>33 57 211 0200 001 33 57 211 0200 002</p>	<p>double ended</p> <p>a = length</p>	
<p>Hybrid cable, single ended, 4 x 2 x AWG 26/7 + 3 x 2.5 mm²</p> <p>Length: 1 m AC version DC version</p> <p>Length: 5 m AC version DC version</p> <p>Length: 10 m AC version DC version</p> <p>Length: 20 m AC version DC version</p>	<p>33 57 111 0010 002 33 57 111 0010 001</p> <p>33 57 111 0050 002 33 57 111 0050 001</p> <p>33 57 111 0100 002 33 57 111 0100 001</p> <p>33 57 111 0200 002 33 57 111 0200 001</p>	<p>Protection level: IP65 / IP67</p> <p>Data part: Transmission properties in accordance with ISO/IEC 11801:2002: Class D</p> <p>single ended</p> <p>a = length</p>	
<p>Hybrid outdoor cable</p> <p>Length: 10 m</p> <p>Length: 20 m</p> <p>Length: 500 m</p>	<p>33 57 851 0100 001</p> <p>33 57 851 0200 001</p> <p>33 57 851 5000 001</p>	<p>PVC jacket 4 x 2 x AWG 26/7 + 3 x 2.5 mm² Outer diameter: 12 mm Min. bending radius: single: 5 x OD repeated: 10 x OD</p>	



Han® 3 A LC duplex Hybrid

Advantages

- Small form factor (compared to SC and ST®)
- Compact, space-saving Design
- Combined to only one LWL-module for high mechanical load
- High packing density
- A & B parts identification according to TIA 568 standard

Technical characteristics

Degree of protection	IP65 / IP67
Temperature range	-40 °C ... +70 °C
Data	
Mating module	LC duplex (2 fibres)
Cable diameter	6.0 ... 9.0 mm
Power	
Number of contacts	3 (AC: L1, PE, N / DC: V+, GND, V-)
Working voltage	300 V AC/DC
Working current	12 A @ 70°C
Housing material	Aluminium die-cast, black

Identification	Part number	Drawing	Dimensions in mm	
Components device side				
Power: 3x Han D® male contacts				
Data: Multimode GOF	AC DC	09 57 568 0500 000 09 57 568 0510 000		
Data: Singlemode GOF	AC DC	09 57 568 0501 000 09 57 568 0511 000		
Connector				
Power: 3x Han D® female contacts				
Data: Multimode GOF	AC DC	09 57 508 0500 000 09 57 508 0510 000		
Data: Singlemode GOF	AC DC	09 57 508 0501 000 09 57 508 0511 000		

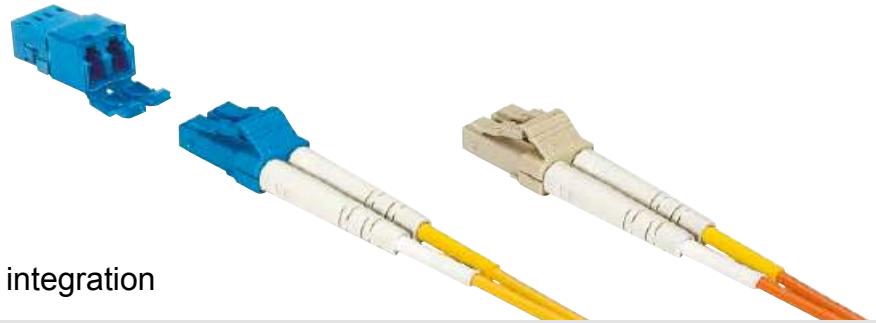

LC duplex IP20 adapter for device integration

Advantages

- Small form factor (compared to SC and ST®)
- Compact, space-saving Design
- High packing density
- A & B parts identification according to TIA 568 standard
- Complement adapter for IP67 connector on device side

Technical characteristics

Degree of protection	IP20
Mating interface	LC duplex with two fibres
Temperature range	-40 °C ... +70 °C

Identification

Part number

Drawing

Dimensions in mm

Device side Adapter

Multimode GOF

09 57 400 0003 000

Singlemode GOF

09 57 400 0004 000

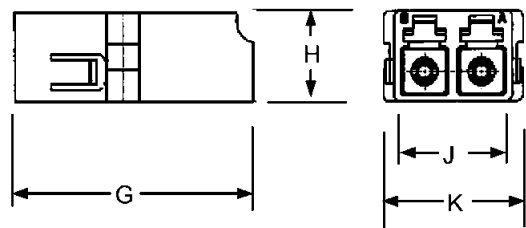

	min.	max.
G	26.60	26.80
H	9.35	9.45
J	12.80	12.90
K	15.24	15.34

Connector LC duplex

Multimode GOF

09 57 400 0001 000

Singlemode GOF

09 57 400 0002 000

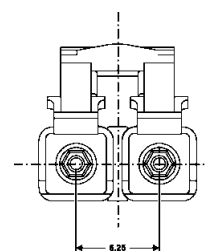
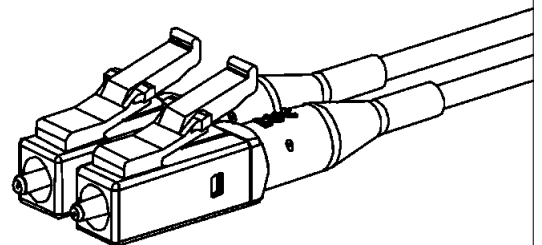



Han® 3 A RJ45, Hybrid

General information

With the RJ Industrial Hybrid connector, HARTING has developed an interface solution that integrates the data lines and the power supply into one connector for hybrid Ethernet networks. The connector's geometry nevertheless maintains a clear separation between the data and the power contacts. This brings a significant reduction in the costs of installation and of field devices suitable for industrial application with hybrid cabling.

The panel feed-through is compatible with RJ45 connectors, which means that the standard patch cables for service and test purposes can be used. The data lines are connected at the rear via an RJ45 jack, while the power lines use a cage clamp terminal.

Optional the hybrid interface can be integrated in the device directly, thus preventing the use of rear side data lines.

The four power contacts of the hybrid module have also been designed with HARAX® rapid termination technology, allowing stranded cables of up to 1.5 mm² to be connected.

Current carrying capacity „Power contacts“

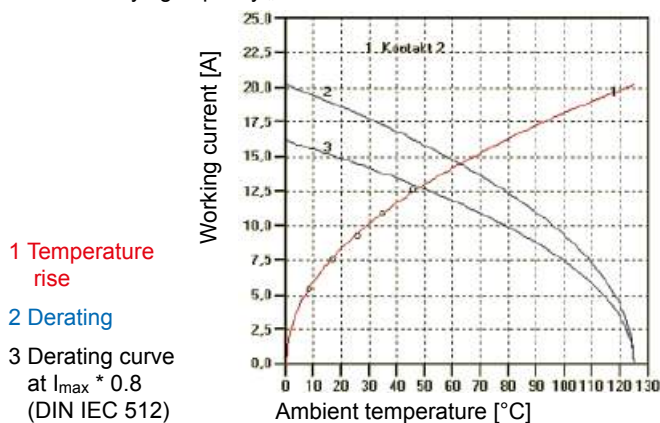

Technical characteristics

Connector	
Degree of protection	IP65 / IP67
Mating interface	RJ45, 4-poles acc. to IEC 60603-7 plus 4x power
Temperature range	-40 °C ... +70 °C
Housing material	
Plastic version	UL 94 V0, black
Metal version	Zinc die-cast, grey
Mating cycles	min. 500
Mounting	field-assembly
Data Cat. 5, 4-poles	
Transmission performance	Category 5 / Class D up to 100 MHz acc. to ISO/IEC 11801:2002, prEN 50173-1
Transmission rate	10/100 Mbit/s
Cable diameter	
stranded	AWG 24/7 - AWG 22/7
solid	AWG 23/1 - AWG 22/1
Data Cat. 6, 8-poles	
Transmission performance	Category 6 / Class EA up to 500 MHz acc. to ISO/IEC 11801:2002, prEN 50173-1
Transmission rate	10/100 Mbit/s / 1 Gbit/s
Cable diameter	
stranded / solid	AWG 27 - AWG 22
Both, data Cat. 5 and Cat. 6	
Shielding	fully shielded, 360° shielding contact
Cable outer diameter	10.0 mm – 11.0 mm
Power	
Number of contacts	4 for cable diameter 1.5 mm ² stranded
Working voltage	48 V
Working current	16 A, see current carrying capacity
	UL approved (E102079)
Panel feed-through	
Mating interface extern:	RJ45 female acc. to IEC 60603-7 plus 4 x power
Mating interface intern:	RJ45 female acc. to IEC 60603-7 4 x power via cable cage clamp 1.5 mm ²

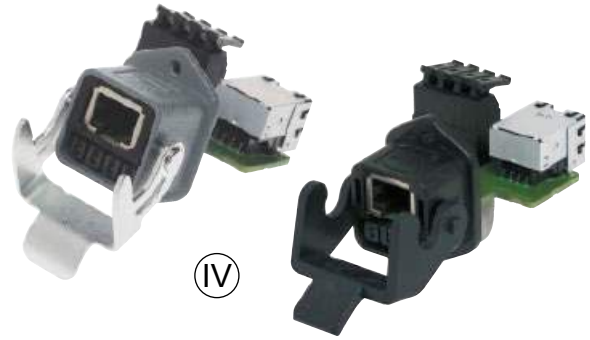
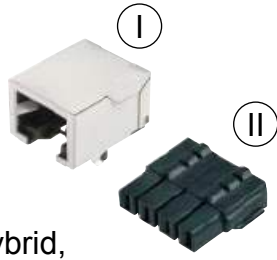

Han® 3 A, Hybrid,
components device side
panel feed-throughs

Identification	Part number	Drawing	Dimensions in mm
RJ45 female for direct device integration solder variant SMD 90° angled I	09 45 551 1100 ¹⁾ 09 45 551 1110 ²⁾		pcb layout
Power module with 4 contacts for direct device integration Reel with 100 pieces II	09 45 525 0040 09 45 525 0041		recommended PCB power layout (SMD) scale: 4:1
Housing bulkhead mounting separate incl. flat seal for direct device integration Plastic version, black Metal version Standard, grey Metal version M, black Metal version EMC, unpainted III	09 45 525 0021 10 12 005 1004 09 45 525 0027 09 45 525 0028		<p>Dimensions valid for plastic version</p>
Panel feed-through set Plastic version, black, Cat. 5 Metal version Standard, grey, Cat. 5 Metal version M, black, Cat. 5 Metal version Standard, grey, Cat. 6 Metal version M, black, Cat. 6 IV	09 45 225 1300 10 12 005 1002 09 45 215 1301 09 45 215 1760 09 45 215 1761		
Protection cover for panel feed-through IP65 / IP67 Plastic version, black Metal version Standard, grey Metal version M, black	09 20 003 5449 09 20 003 5425 09 37 003 5405		

1) Packaging: Blister à 120 pieces
2) Packaging: Tape & Reel à 130 pieces
Technical characteristics and general informations see page 04.15



Han® 3 A RJ45, Hybrid

Identification	Part number	Drawing	Dimensions in mm
Connector, Cat. 5, 4 + 4-poles (IDC termination for RJ45 insert)			
Plastic version, black	09 45 125 1300		
Metal version Standard, grey	10 12 005 2001		
Connector, Cat. 6, 8 + 4-poles (IDC termination for RJ45 insert)			
Plastic version, black	09 45 125 1760		
Metal version Standard, grey	09 45 115 1760		
Connector insert for Han® 3 A housings	09 45 100 1760		
Connector, Cat. 6, 8 + 4-poles (with piercing connection AWG 28/7 - 24/7)			
Plastic version, black	09 45 125 1720		
Metal version Standard, grey	09 45 115 1720		
Connector insert for Han® 3 A housings	09 45 100 1720		
suitable assembly tool	09 45 800 0520		
Protection cover for connector IP65 / IP67 without seal			
Plastic version, black	09 20 003 5442		
Metal version Standard, grey	09 20 003 5422		
Metal version M	09 37 003 5402		

Dimensions valid for plastic version

PROFINET Type B cable, Hybrid
Industrial Cat. 5 Hybrid cable, 4-wire + 4x Power
to make up Hybrid system cables

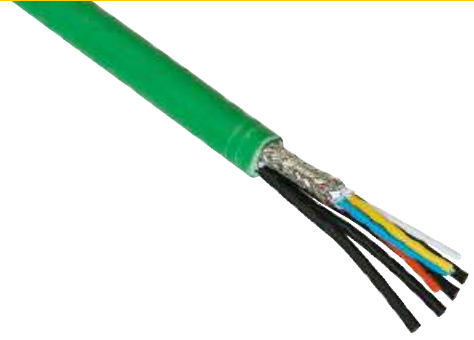

Han

Advantages

- Robust design for industrial environment
- PROFINET-conform
- Additional power supply
- Hybrid Cat. 5 cable, 4-wire + 4x Power

Technical characteristics

Cable construction	Star quad + 4 Power cables, double shielded
Core structure	4 x AWG 22/7 + 4 x 1.5 mm ² (conductor 84 x 0.15 mm ²)
Sheath material	FRNC
Cable outer diameter	9.7 mm
Transmission performance	Category 5 / Class D up to 100 MHz acc. to ISO/IEC 11801:2002, EN 50 173-1
Transmission rate	10/100 Mbit/s
Shielding	Shielding foil and shielding braid
Temperature range	-20 °C ... +70 °C
Standard lengths	10 m / 20 m / 50 m / 100 m
Colour	green

Identification

PROFINET Type B cable, Hybrid
Industrial Cat. 5 Hybrid cable,
4-wire + 4x Power

10 m ring
20 m ring
50 m ring
100 m ring
500 m reel

Part number

09 45 600 0310
09 45 600 0330
09 45 600 0340
09 45 600 0300
09 45 600 0320

Drawing



Dimensions in mm



Industrial Cat. 6 Hybrid
Installation cable, 8-wire

Advantages

- Robust design for industrial environment
- PROFINET-conform
- Additional power supply
- Hybrid Cat. 6 cable, 4-wire + 4x Power

Technical characteristics

Cable structure	4 x 2, Twisted Pair, shielded, PIMF 4 power cores
Core structure	4 x 2 x AWG 26/7, stranded 4x 84 * 0.15 mm (cord 1.5 mm²), stranded
Sheath material	PUR
Cable sheath diameter	10 ... 10.6 mm
Transmission performance	Category 6 / Class E up to 250 MHz according to ISO/IEC 11801:2002, EN 50 173-1
Transmission rate	10/100/1000 Mbit/s
Shielding	Paired shielded with additional cable shield
Operating temperature range	-20 °C ... +80 °C
Supply lengths	20 m / 50 m / 100 m other lengths on request
Colour	black

Identification

Industrial Cat. 6 Hybrid
installation cable,
8-wire
PUR

20 m ring
50 m ring
100 m drum

Part number

09 45 600 0332
09 45 600 0342
09 45 600 0302

Drawing



Dimensions in mm

Features

General Description

The Han-Brid® series allows the connection of a data interface and a power supply in a single space saving connector. This means that it is now possible to provide data transmission and power to devices in a single bus structure. This hybrid connector family includes provision for connection of a max. 50 V, 10 A power supply together with a range of inserts for connection of a variety of data protocols and transmission medias:

- Han-Brid® F.O. for plastic (POF) or for HCS®* optical fibre
- Han-Brid® Cu for shielded twisted pair.
- Han-Brid® Quintax 3 A for shielded 4 wire bus systems (2 pair STP)
- Han-Brid® RJ45 C for Ethernet application
- Han-Brid® USB / Firewire for fast data transmission

Han-Brid® inserts fit to the standard plastic as well as metal hoods and housings with seal of the Han® 3A series offering a degree of protection IP65 according to DIN EN 60 529. For harsher environments Han® 3 HPR hoods and housings with a degree of protection of IP68 can be used.

Power supply

- Han D® male and female with standard crimp contacts
- Rated current 10 A
- Rated voltage 50 V
- Wire gauge 0.14 - 2.5 mm²
- Approval 

Data interfaces

Han-Brid® F.O.

- Is suitable for all HP Versatile Link (Horizontal Package) transmitters and receivers
- Data rates: Standard 12 Mbit/s, suitable for all common fieldbus systems
- Insert allows integration of HP standard contacts for POF and HCS®* fibres
- Temperature range -40 °C ... +70 °C

Han-Brid® Cu

- For termination of a shielded twisted pair
- Insert for 2x Han D® male or female contacts
- Connection of the shield by means of shielding plate and fixing clamps
- Connection of the device side can be realized either by a printed circuit board as a modular version or as part of the appliance PCB
- Insert for bulkhead mounted housing or the coupling housing are always equipped with a screening spring

Bus Terminator

- Active bus terminator in male and female version
- Standard Han® 3 A hoods and housings
- Power supply to the termination network via electrical contacts of Han-Brid®
- Integrated, galvanically separated DC/DC converter 24 V / 5 V

Han-Brid® Quintax 3 A

- Possibility to terminate shielded 4 wires conductors (2 pair STP)
- Suitable for all 4-wire bus systems
- Suitable for shielded cable conductor diameter 3 – 9.5 mm
- Transmission of shielding separately from the hood's ground
- Connections are carried out acc. to DIN EN 50 173, Cat. 5
- Temperature range -40 °C ... +70 °C

Han-Brid® RJ45 C

- Suitable for standard RJ45 Plug and Jack, shielded version
- Connections provided for conductors acc. to DIN EN 50 173, Cat. 5
- Termination from the device side is carried out via a PCB, two versions are possible: modular version or as part of the appliance PCB
- Assembly with standard tools
- Insert for 2 Han-D® male or female contacts offers the combination with electrical bus connector
- Rated current 10 A
- Rated voltage 24 V
- Wire gauge 0.14 - 2.5 mm²

Han-Brid® USB

- Insert for all Han® 3 A hoods and housings
- Hood with glued sealing
- Simple and low-cost termination via insert of a patch cable
- Strain-relief via cable tie

Han-Brid® FireWire

- Insert for all Han® 3 A hoods and housings
- Hood with glued sealing
- Simple and low-cost termination via insert of a patch cable
- Strain-relief via cable tie
- Compatible to IEEE 1394

* HCS® Hard Clad Silica (is registered trade mark of the SpecTran Corporation)

Overview (Sample: Han-Brid® Cu)

Thermoplastic
 09 20 003 0320 (light grey)
 09 20 003 0327 (black)

Metal
 09 20 003 0301

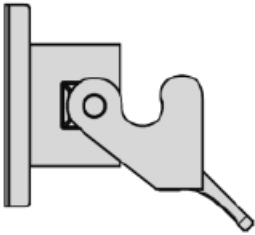

Device side
 09 12 006 2611
 09 12 006 2695
 09 12 006 2694

Cable side
 09 12 006 3111

Thermoplastic
 09 20 003 0423 (light grey)
 09 20 003 0426 (black)
 19 20 003 0423 (light grey)
 19 20 003 0427 (black)

Metal
 09 20 003 1443
 19 20 003 1443

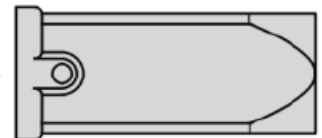
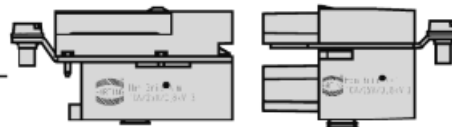

Thermoplastic
 09 20 003 0720 (light grey)
 09 20 003 0727 (black)
 19 20 003 0720 (light grey)
 19 20 003 0727 (black)

Metal
 09 20 003 1750
 19 20 003 1750

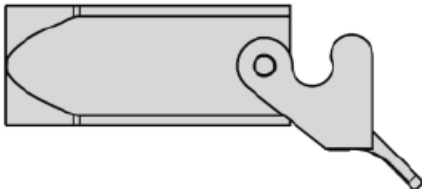

Device side
 09 12 006 2701
 09 12 006 2795
 09 12 006 2794

Cable side
 09 12 006 3001

Thermoplastic
 09 20 003 0623 (light grey)
 09 20 003 0626 (black)
 19 20 003 0623 (light grey)
 19 20 003 0627 (black)

Metal
 09 20 003 1643
 19 20 003 1643

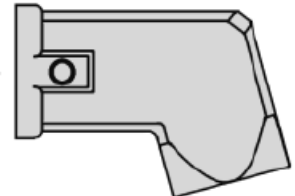



Thermoplastic
 09 20 003 0220 (light grey)
 09 20 003 0227 (light grey)
 19 20 003 0220 (light grey)
 19 20 003 0227 (black)

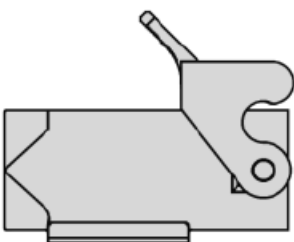



Metal
 09 20 003 1250
 19 20 003 1250

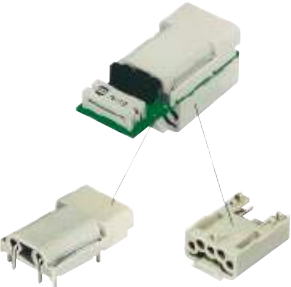
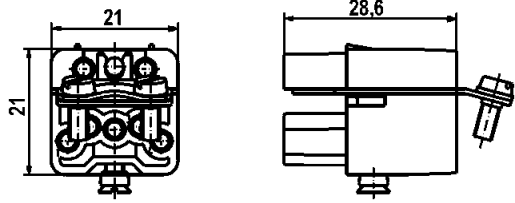
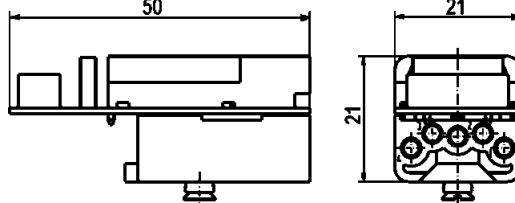

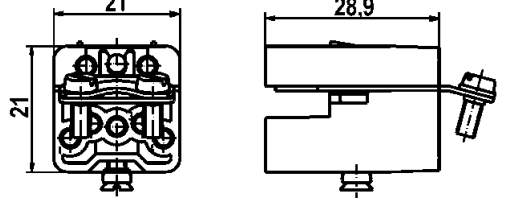
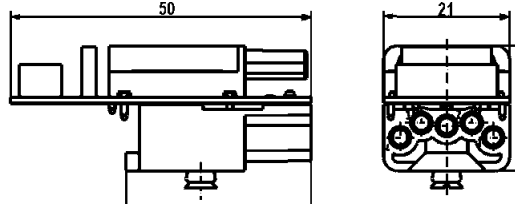
Hybrid field bus connector
for shielded twisted pair
+ 4 electrical contacts 10 A
+ option for PE

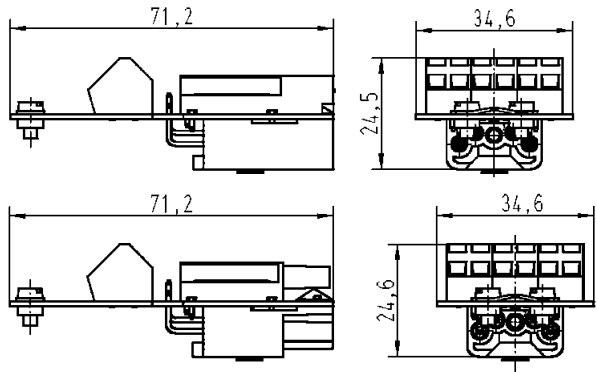

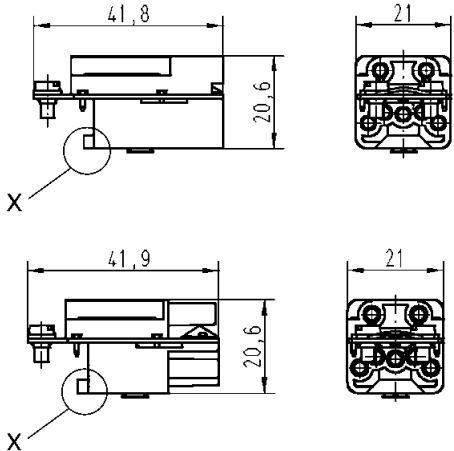
Identification	Part number		Drawing	Dimensions in mm
	Male insert (M)	Female insert (F)		
<p>Cable side Female insert</p>  <p>Device side Male insert</p> 	<p>09 12 006 3111</p>		 <p>View from termination side</p> 	
	<p>09 12 006 2611</p> <p>Also available as single part</p> <p>loaded 09 12 002 2611 unloaded 09 12 002 3011</p>	<p>Also available as single part</p> <p>unloaded 09 12 004 3011</p>		
<p>Cable side Male insert</p>  <p>Device side Female insert</p> 	<p>09 12 006 3001</p>		 <p>View from termination side</p> 	
	<p>09 12 006 2701</p> <p>Also available as single part</p> <p>loaded 09 12 002 2701 unloaded 09 12 002 3101</p>	<p>Also available as single part</p> <p>unloaded 09 12 004 3101</p>		

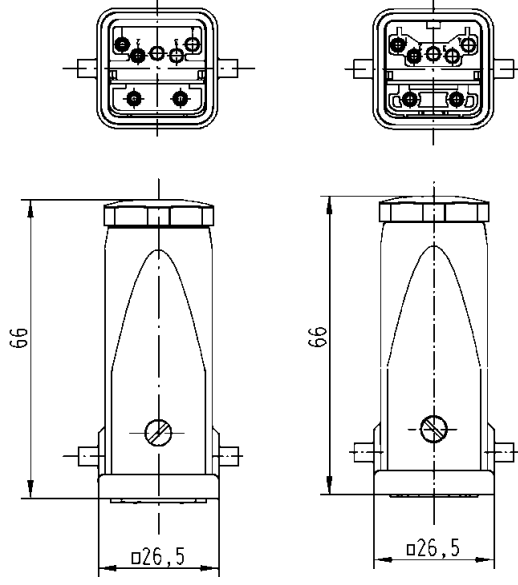
Identification	Part number		Drawing	Dimensions in mm
	Male insert (M)	Female insert (F)		
<p>Panel feed-through with cage clamp</p> 	09 12 006 2695			
		09 12 006 2795		
<p>Coupling / Panel feed-through</p>  <p>X = Cutting off the fin allows the use in cable to cable housings</p>	09 12 006 2694			
		09 12 006 2794		
<p>Bus terminator</p> <p>Plastic hoods/housings</p>  <p>Hoods/Housings, metal</p> 	09 12 006 2691	09 12 006 2791		
	09 12 006 2692	09 12 006 2792		

Hybrid field bus connector
with F.O. transmitter and receiver
+ 4 electrical contacts 10 A
+ option for PE



Identification	Part number		Drawing	Dimensions in mm
	Male insert (M)	Female insert (F)		
<p>Cable side F.O. (m) + Han D® (f)</p>	<p>Also available as single part</p> <p>for POF 09 12 004 2711</p> <p>for POF crimpless 09 12 004 2713</p> <p>for HCS®* fibre 09 12 004 2716</p>	<p>Also available as single part</p> <p>for POF 09 12 004 3111</p> <p>for POF crimpless 09 12 004 3113</p> <p>for HCS®* fibre 09 12 004 3116</p>	<p>View from termination side</p>	
<p>Device side F.O. (f) + Han D® (m)</p>	<p>for POF 09 12 004 2611</p> <p>for POF crimpless 09 12 004 2611</p> <p>for HCS®* fibre 09 12 004 2611</p>	<p>for POF 09 12 004 3011</p> <p>for POF crimpless 09 12 004 3011</p> <p>for HCS®* fibre 09 12 004 3011</p>	<p>View from termination side</p>	
<p>Cable side F.O. (m) + Han D® (m)</p>	<p>Also available as single part</p> <p>for POF 09 12 004 2601</p> <p>for POF crimpless 09 12 004 2603</p> <p>for HCS®* fibre 09 12 004 2606</p>	<p>Also available as single part</p> <p>for POF 09 12 004 3001</p> <p>for POF crimpless 09 12 004 3003</p> <p>for HCS®* fibre 09 12 004 3006</p>	<p>View from termination side</p>	
<p>Device side F.O. (f) + Han D® (f)</p>	<p>for POF 09 12 004 2701</p> <p>for POF crimpless 09 12 004 2701</p> <p>for HCS®* fibre 09 12 004 2701</p>	<p>for POF 09 12 004 3101</p> <p>for POF crimpless 09 12 004 3101</p> <p>for HCS®* fibre 09 12 004 3101</p>	<p>View from termination side</p>	

* HCS®=Hard Clad Silica (is registered trade mark of the SpecTran Corporation)

4 contacts + shielding
+ 2 power contacts
suitable in Han® 3 A metric
hoods and housings



Identification	Part number		Drawing	Dimensions in mm
	Male insert (M)	Female insert (F)		
Quintax insert 	09 15 003 3001	09 15 003 3101		
Quintax contacts Zinc alloy Order crimp contacts separately Special clamp for cable diameter 3 - 6 and 6 - 9.5 mm included in delivery range	09 15 004 3013	09 15 004 3113		

Assembly instructions

Quintax-Z-contact

- Strip cable acc. to drawing 1 and fold the shielding over the cable.
- Crimp Han D® contacts onto the wires.
- Insert Han D® contacts into corresponding cavities of insulator until they are snapped in.
- Fit the insert including the cable into the opened shielded bushing. The coding pin of the shielded bushing has to meet the groove of the insulator.
- Clamp the tilt over the shielding onto the cable by means of the special clamp (small opening for cable diameter of 3 - 6 mm, large opening for cable diameter of 6 - 9.5 mm).
- Check the wiring.
- Close the shielded bushing with the cover and insert it into the corresponding cavity of the Quintax Module as usual.

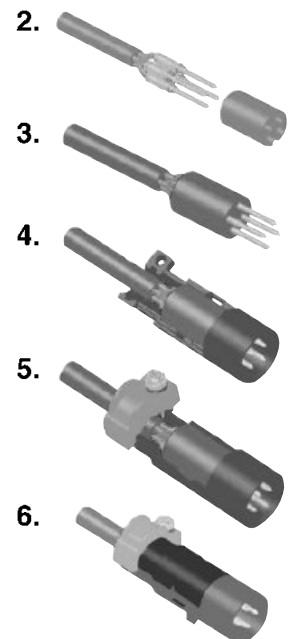
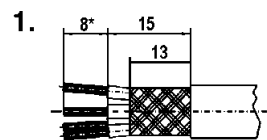

Hybrid network connector
+ 2 electrical contacts 10 A



Identification

Part number

Drawing

Dimensions in mm

Han-Brid® RJ45 C
with RJ Industrial



09 12 003 3011

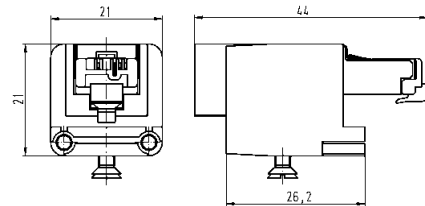

Han-Brid® RJ45 C
with Stewart RJ45



09 12 003 3021

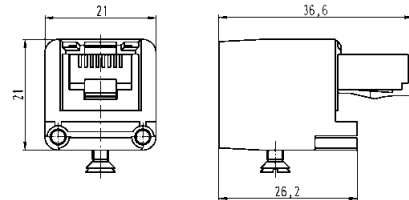

Han-Brid® RJ45 C
with HIROSE RJ45



09 12 003 3031

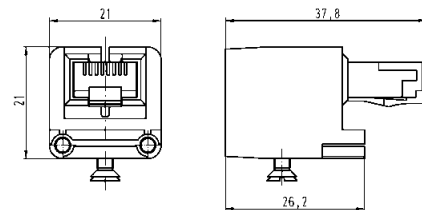

Panel feed-through
straight



09 12 003 2774

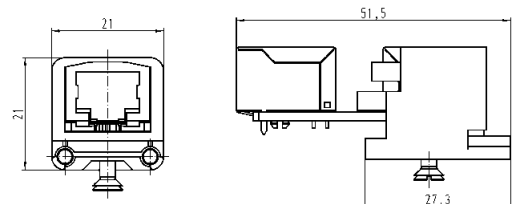

Panel feed-through
angled



09 12 003 2776

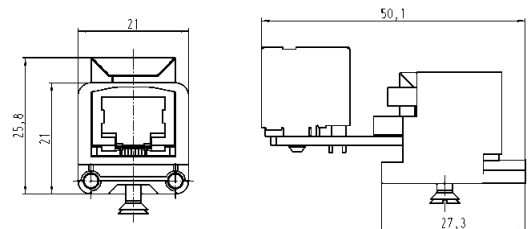

Panel feed-through
with 4-pole terminal block



09 12 003 2770

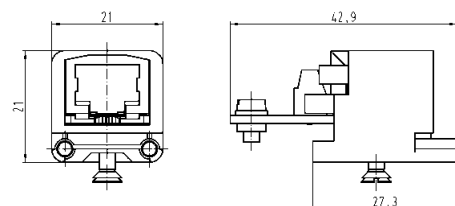

Han-Brid® USB

Features

- Insert for all Han® 3 A hoods and housings
- Hood with glued sealing
- Simple and low-cost termination via insert of a patch cable
- Strain-relief via cable tie

Technical characteristics

USB style A, 2.0 Standard

Specifications	DIN VDE 0110 DIN EN 61984
Number of contacts	4
Electrical data acc. to EN 61984	1 A 50 V 0.8 kV 3
Rated current	1 A
Rated voltage	50 V
Rated impulse voltage	0.8 kV
Pollution degree	3
Material	Polycarbonate
Insulation resistance	$\geq 10^{10} \Omega$
Contact resistance	$\geq 4 \text{ m}\Omega$
Temperature range	-40 °C ... 85 °C
Flammability acc. to UL 94	V0
Mechanical working life - mating cycles	≥ 500

Han-Brid® FireWire

Features

- Insert for all Han® 3 A hoods and housings
- Hood with glued sealing
- Simple and low-cost termination via insert of a patch cable
- Strain-relief via cable tie
- Compatible to IEEE 1394

Technical characteristics

Firewire IEEE 1394

Specifications	DIN VDE 0110 DIN EN 61984
Number of contacts	6
Electrical data acc. to EN 61984	1 A 50 V 0.8 kV 3
Rated current	1 A
Rated voltage	50 V
Rated impulse voltage	0.8 kV
Pollution degree	3
Material	Polycarbonate
Insulation resistance	$\geq 10^{10} \Omega$
Contact resistance	$\geq 4 \text{ m}\Omega$
Temperature range	-40 °C ... 85 °C
Flammability acc. to UL 94	V0
Mechanical working life - mating cycles	≥ 500

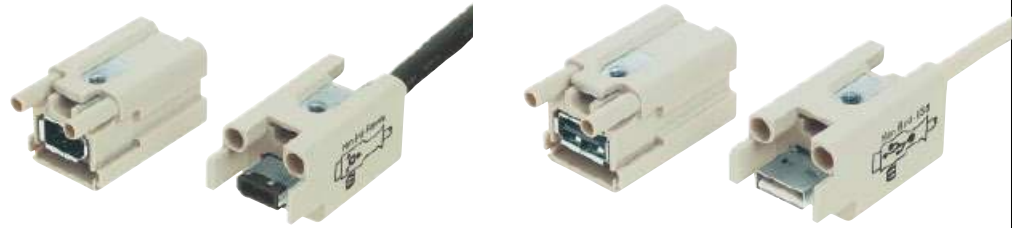

Identification	Part number		Drawing	Dimensions in mm
	Male insert (M)	Female insert (F)		

<p>Han-Brid® USB</p>	<p>09 12 001 2794</p>	<p>09 12 001 3091</p>	
----------------------	------------------------------	------------------------------	--

<p>Han-Brid® FireWire</p>	<p>09 12 001 2774</p>	<p>09 12 001 3071</p>	
---------------------------	------------------------------	------------------------------	--



Insert	Part number		Drawing	Dimensions in mm
	Male insert (M)	Female insert (F)		
Order contacts separately	09 12 005 3001	09 12 005 3101		
1) Distance for contact max. 21 mm				
PCB-adapter	Part number		Drawing	Dimensions in mm
with PE contact panel for Han® Q 5/0	09 12 000 9905		<p>Adapter</p>	<p>PE contact panel</p>
Solder contacts	Part number		Drawing	Dimensions in mm
to connect the PCB-adapter	Male contact	Female contact		
	09 33 000 6195	09 33 000 6295		
Housing bulkead mounting	Part number		Drawing	Dimensions in mm
	09 62 003 0304		<p>Panel cut out 22 x 22 mm</p>	

Han

Device side

Cable side

Features

- ❑ Robust design
- ❑ Suitable for EMC housings
- ❑ Low wiring costs
- ❑ Additional robust and secure PE-connection between housing and PCB

Technical characteristics

Approvals



Inserts

Number of contacts 5

Electrical data acc. to DIN EN 61984

10 A 230/400 V 4 kV 3

Working current
 Working voltage conductor – ground
 Working voltage conductor – conductor
 Rated impulse voltage
 Pollution degree

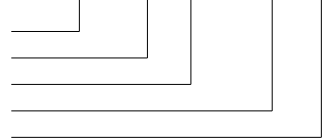

- pollution degree 2 also 10 A 320/500 V 4 kV 2

Working voltage acc. to UL/CSA 400 V

Insulation resistance $\geq 10^{10} \Omega$
 Material Polycarbonate
 Limiting temperatures $-40^\circ\text{C} \dots +125^\circ\text{C}$
 Flammability acc. to UL 94 V0
 Mechanical working life
 - Mating cycles ≥ 500

Layout of printed circuit boards

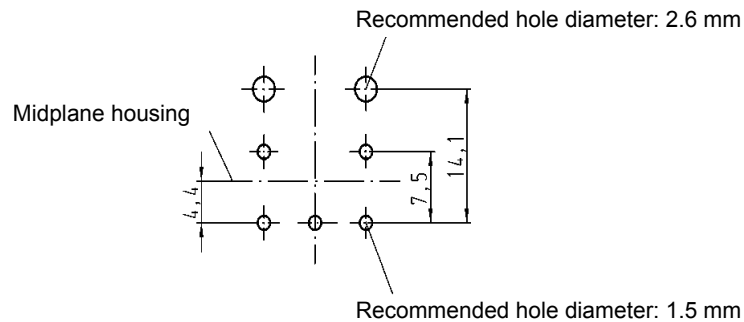

Assembly situation

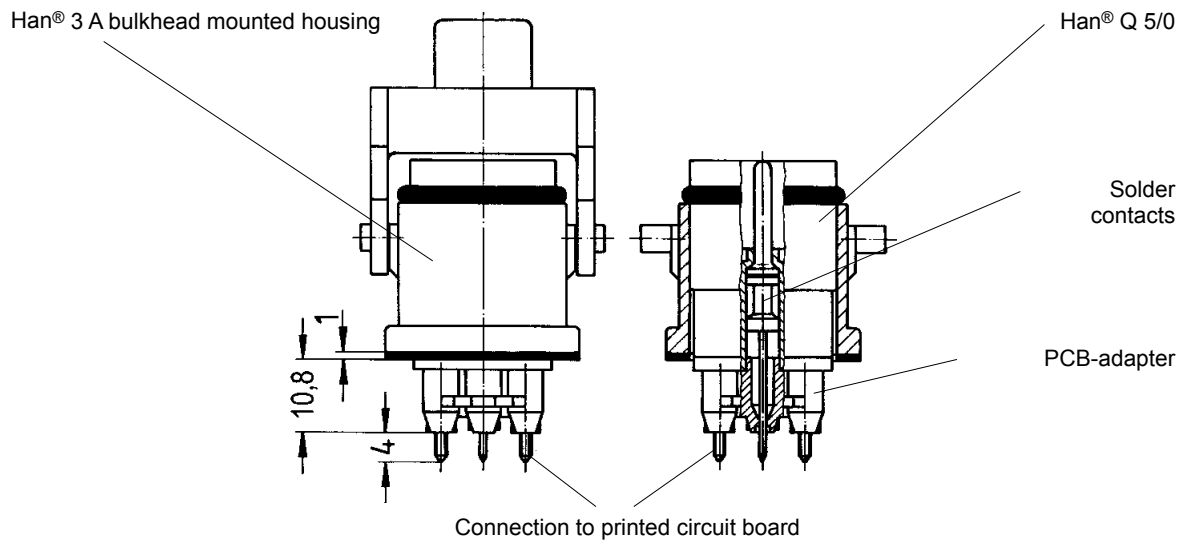

Han



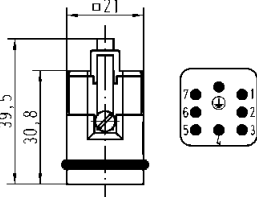
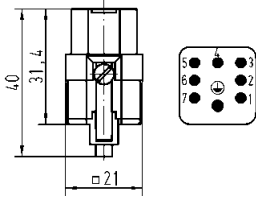

Han

Device side

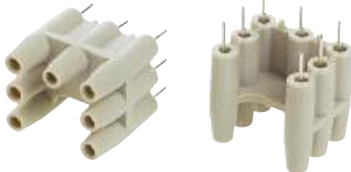
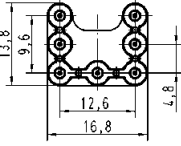
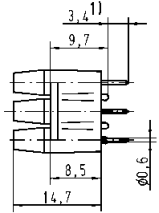
Insert	Part number		Drawing	Dimensions in mm
	Male insert (M)	Female insert (F)		
Order contacts separately 	09 12 007 3001	09 12 007 3101		
Coding	09 12 000 9901	09 12 000 9902		

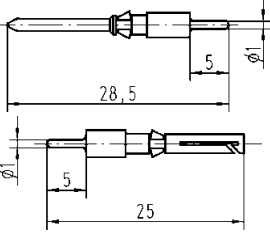
PCB-adapter	Part number	Drawing	Dimensions in mm
for PCB up to 2.4 mm 	09 12 000 9908		

Solder contacts	Part number		Drawing	Dimensions in mm
	Male contact	Female contact		
to connect the PCB-adapter 	09 15 000 6190	09 15 000 6290		

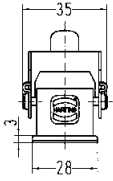
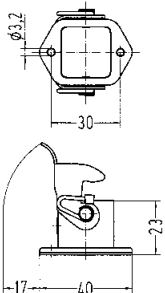
Housing bulkead mounting	Part number	Drawing	Dimensions in mm
	09 20 003 0301	Panel cut out 22 x 22 mm 	

Cable side

Further informations see HARTING catalogue "Industrial Connectors Han®, chapter Q"

Features

- ❑ Robust design
- ❑ Suitable for standard and EMC housings
- ❑ Low cost wiring
- ❑ High contact density

Technical characteristics





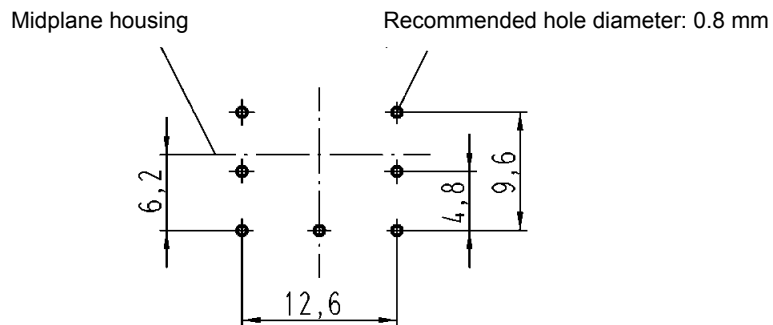



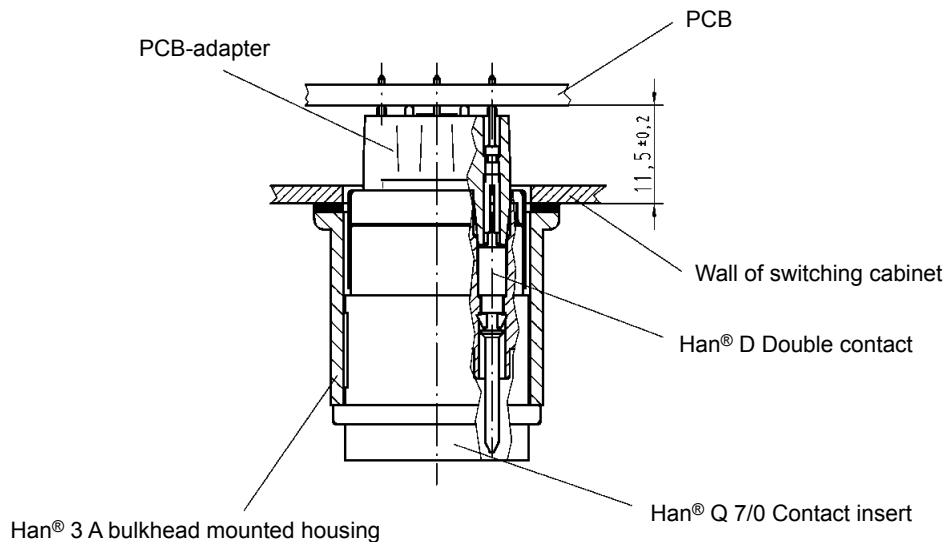

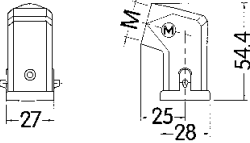
Approvals	
Inserts	
Number of contacts	7
Electrical data acc. to DIN EN 61984	7.5 A 250 V 4 kV 3
Working current	
Working voltage	
Rated impulse voltage	
Pollution degree	
Insulation resistance	≥ 10 ¹⁰ Ω
Material	Polycarbonate
Limiting temperatures	-40 °C ... +125 °C
Flammability acc. to UL 94	V0
Mechanical working life	
- Mating cycles	≥ 500

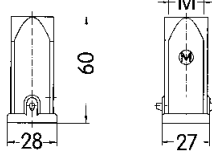
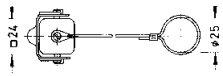
Layout of printed circuit boards

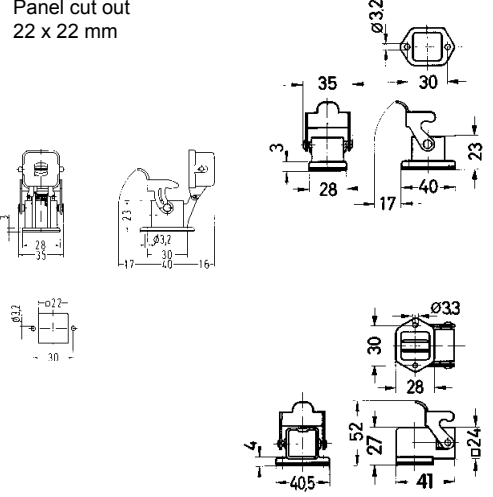

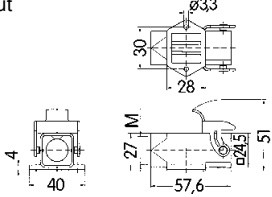

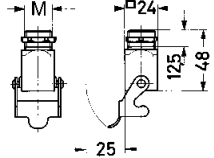

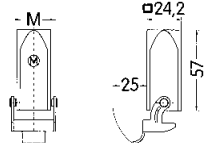
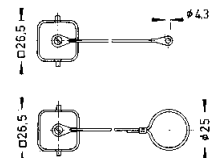
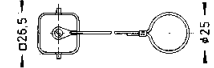



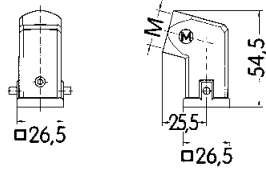

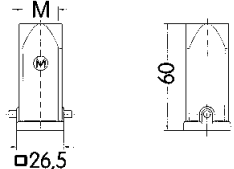
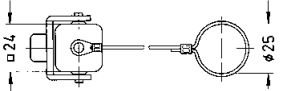

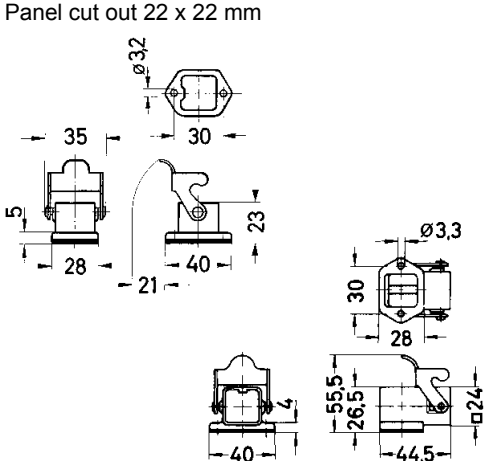

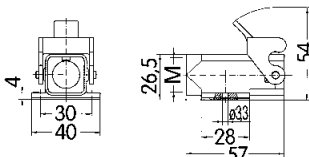
Assembly situation

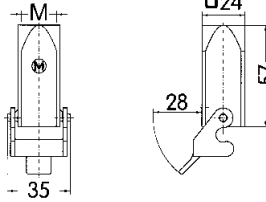

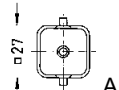
Identification		Part number	M	Drawing	Dimensions in mm
Hoods	Hood side-entry 	19 20 003 1640	20		
	Hood top-entry 	19 20 003 1440	20		
	Protection covers for hoods	09 20 003 5422¹⁾ 09 20 003 5421²⁾			
Housings	Housings bulkhead mounting 	09 20 003 0301		Panel cut out 22 x 22 mm 	
	with fixed cover	09 20 003 0305¹⁾			
	without sealing	09 20 003 0306²⁾			
	with sealing	09 20 003 0801			
	Housing surface mounting 1 side-entry 	19 20 003 1250	20	Panel cut out 22 x 22 mm 	
	bottom closed	19 20 003 1252	20		
	Housing screw mounting 	19 20 003 1150	20		
Hood cable to cable 	19 20 003 1750	20			
Protection covers for housings	09 20 003 5426¹⁾ 09 20 003 5425²⁾				
for hoods cable to cable	09 20 003 5428¹⁾ 09 20 003 5427²⁾				

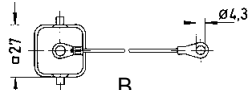
¹⁾ for mounted male insert
²⁾ for mounted female insert

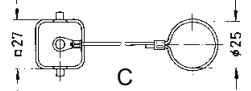
Identification			Part number	M	Drawing	Dimensions in mm
Hoods	Hoods side-entry		grey 19 20 003 0620 black 19 20 003 0627	20 20		
	Hoods top-entry		grey 19 20 003 0420 black 19 20 003 0427	20 20		
	Protection covers for hoods		09 20 003 5442 ¹⁾ 09 20 003 5441 ²⁾			
Housings	Housings bulkhead mounting		grey 09 20 003 0320 black 09 20 003 0327 grey 09 20 003 0820 black 09 20 003 0827	- - - -		Panel cut out 22 x 22 mm
	Housings surface mounting 1 side-entry		grey 19 20 003 0220 black 19 20 003 0227	20 20		Panel cut out 22 x 22 mm
	Hoods cable to cable		grey 19 20 003 0720 black 19 20 003 0727	20 20		
	Protection covers for housings	A 	09 20 003 5407 ¹⁾ 09 20 003 5408²⁾			
		B 	09 20 003 5445²⁾ 09 20 003 5446 ¹⁾ 09 20 003 5447 ²⁾ ³⁾			
	for hoods cable to cable C 	09 20 003 5448 ¹⁾ 09 20 003 5449 ²⁾				

Han

1) for mounted male insert
2) for mounted female or Han-Brid® insert
3) for metal housings and cable to cable hoods also

Stock items in bold type



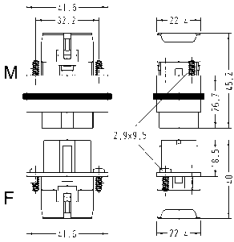
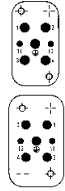

Han

Device side

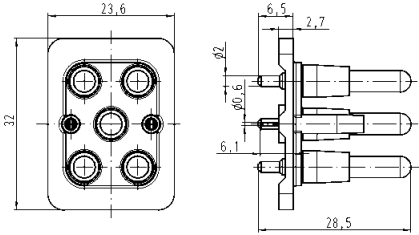
Insert	Part number		Drawing	Dimensions in mm
	Male insert (M)	Female insert (F)		
Order contacts separately 	09 12 006 3041	09 12 006 3141		Contact arrangement View from termination side 

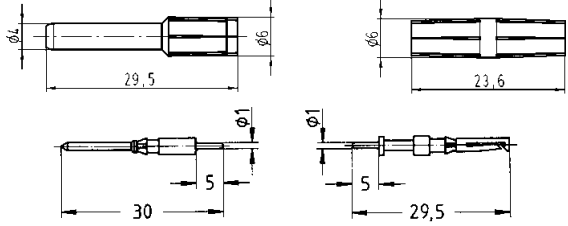
PCB-adapter	Part number	Drawing	Dimensions in mm
for PCBs up to 2.4 mm 	09 12 006 9901		

Han® Q 4/2 double contacts	Part number		Drawing	Dimensions in mm
	Male contact	Female contact		
to connect the PCB adapter Power contact 	09 32 000 6180	09 32 000 6280		
Signal contact 	09 15 000 6191	09 15 000 6293		

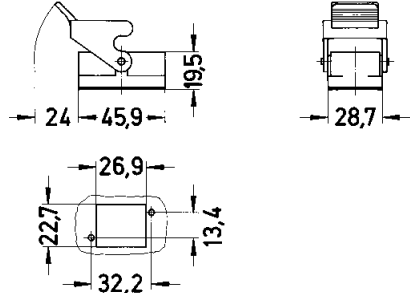
Housing bulkead mounting	Part number	Drawing	Dimensions in mm
Plastic 	09 12 008 0327	Panel cut out 	

Cable side

Further informations see HARTING catalogue "Industrial Connectors Han®, chapter Q"

Features

- ❑ Robust Design
- ❑ Suitable for Han-Compact® hoods and housings
- ❑ Low wiring costs
- ❑ High contact density

Technical characteristics

Approvals	
Number of contacts	4/2 + PE
Electrical data acc. to DIN EN 61984	
Power area	30 A 400/690 V 6 kV 2
Rated current	30 A
Rated voltage	
conductor - ground	400 V
conductor - conductor	690 V
Rated impulse voltage	6 kV
Pollution degree	2
Signal area	7.5 A 250 V 4 kV 2
Rated current	7.5 A
Rated voltage	250 V
Rated impulse voltage	4 kV
Pollution degree	2
Insulation resistance	$\geq 10^{10} \Omega$
Material	LCP
Limiting temperatures	-40 °C ... +125 °C
Flammability acc. to UL 94	V0
Mechanical working life	≥ 500 mating cycles

Layout of printed circuit boards

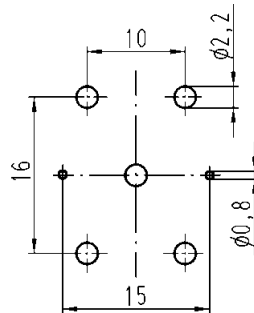

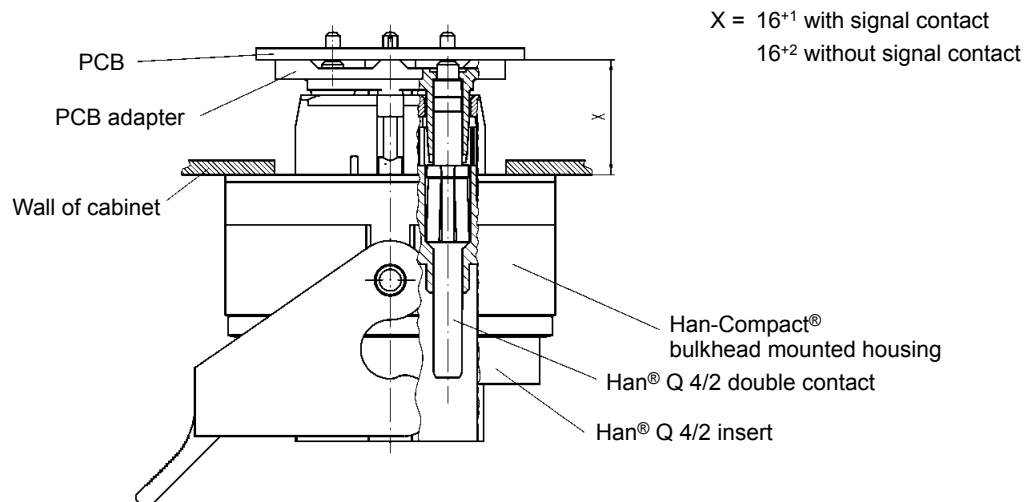

Assembly situation







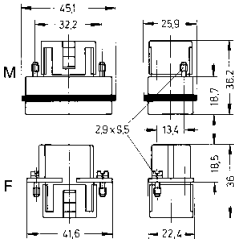

Han

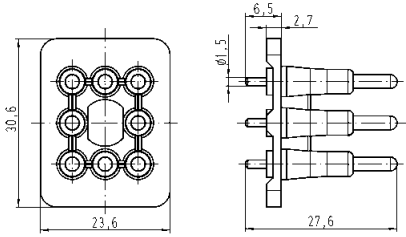
Device side

Insert	Part number		Drawing	Dimensions in mm
	Male insert (M)	Female insert (F)		
Order contacts separately 	09 12 008 3001	09 12 008 3101		Contact arrangement View from termination side 

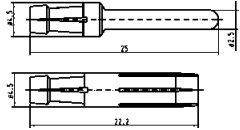
PCB-adapter	Part number	Drawing	Dimensions in mm
for PCBs up to 1.6 mm 	09 12 008 9901		

Han® Q 8/0 double contacts	Part number		Drawing	Dimensions in mm
	Male contact	Female contact		
to connect the PCB adapter 	09 33 000 6180	09 33 000 6280		

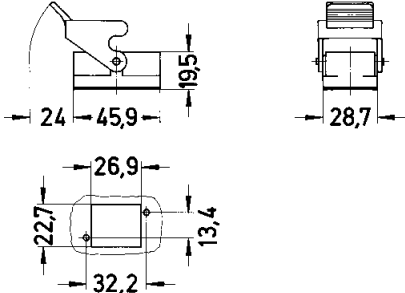
Housing bulkead mounting	Part number	Drawing	Dimensions in mm
Plastic 	09 12 008 0327	Panel cut out 	

Cable side

Further informations see HARTING catalogue "Industrial Connectors Han®, chapter Q"

Features

- ❑ Robust Design
- ❑ Suitable for Han-Compact® hoods and housings
- ❑ Low wiring costs
- ❑ High contact density

Technical characteristics

Approvals	
Number of contacts	8
Electrical data acc. to DIN EN 61984	16 A 230/400 V 4 kV 2
Rated current	16 A
Rated voltage	230 V
conductor - ground	400 V
Rated impulse voltage	4 kV
Pollution degree	2
Insulation resistance	$\geq 10^{10} \Omega$
Material	LCP
Limiting temperatures	-40 °C ... +125 °C
Flammability acc. to UL 94	V0
Mechanical working life	≥ 500 mating cycles

Layout of printed circuit boards

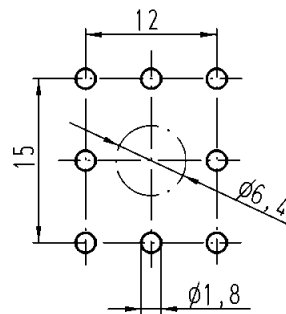

Assembly situation

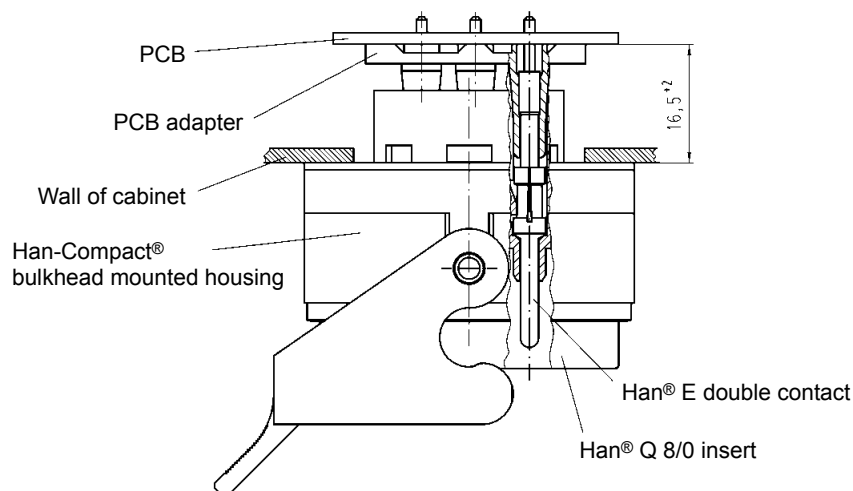

thermoplastic / metal

Identification

Part number

Drawing

Dimensions in mm

Hoods

Hoods

Thermoplastic
side-entry
Cable gland order separately



09 12 008 0527

Pg 16

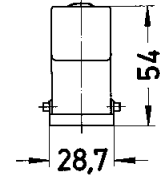
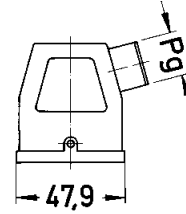

Hoods

Thermoplastic
top-entry
Cable gland order separately



19 12 008 0429
09 12 008 0427
09 12 008 0429

M 25
Pg 16
Pg 21

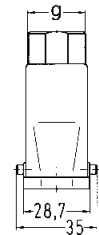
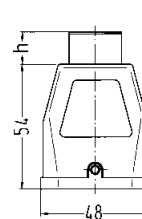

h	g
14	M 25x1.5
13	Pg 16
13	Pg 21

Hoods

Thermoplastic
top-entry
Cable gland order separately



09 12 008 0428

Pg 16

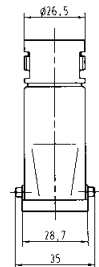
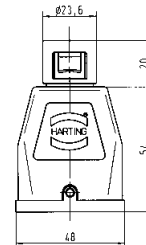

Cable seal

Thermoplastic
for hoods
Thrust bolt and insert



09 00 000 5059
19 12 000 5157
19 12 000 5158
09 00 000 5157
09 00 000 5158

Pg 16
M 25
M 25
Pg 21
Pg 21

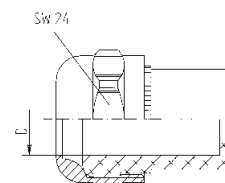

	cable	
	min.	max.
09 00 000 5059	11.5 mm	15.5 mm
19 12 000 5157	10.5 mm	14 mm
19 12 000 5158	14 mm	17 mm
09 00 000 5157	14 mm	18 mm
09 00 000 5158	17 mm	20.5 mm

thermoplastic / metal

Identification

Part number

Drawing

Dimensions in mm

Hoods

Hoods

Metal
side-entry
Cable gland order separately



19 12 008 0526

M 25

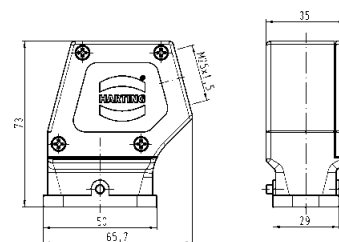

Hoods

Metal
side-entry
Cable gland order separately



black
chromated
19 12 008 0501

M 25

black
powder coated
19 12 708 0501

M 25

matt
nickel plated
19 12 008 0502

M 25

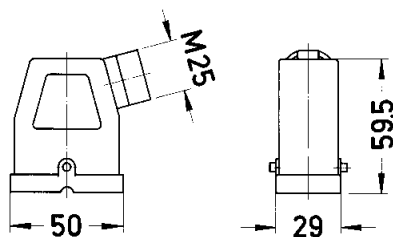

Hoods

Metal
top-entry
Cable gland order separately



19 12 008 0426

M 25

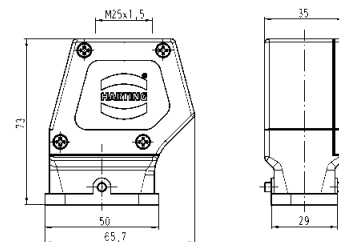

Cable seal

Metal
for hoods
Thrust bolt and insert



19 12 000 5057
19 12 000 5058

M 25
M 25

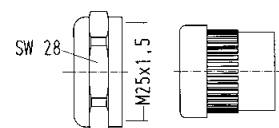

	cable	
	min.	max.
19 12 000 5057	10.5 mm	14 mm
19 12 000 5058	14 mm	17 mm

Identification

Part number

Drawing

Dimensions in mm

for male insert

for female insert

Protection covers

Thermoplastic
for male insert



without sealing
09 12 008 5407

with sealing
09 12 008 5408

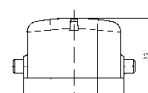

Han

thermoplastic / metal

Identification

Part number

Drawing

Dimensions in mm

Housings

Housings,
bulkhead mounting

Thermoplastic
angled



09 12 008 0902

Pg 16

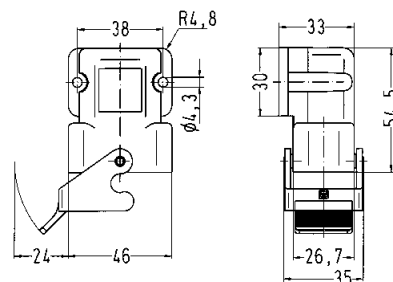

Housings,
bulkhead mounting

Thermoplastic



09 12 008 0327

Pg 16

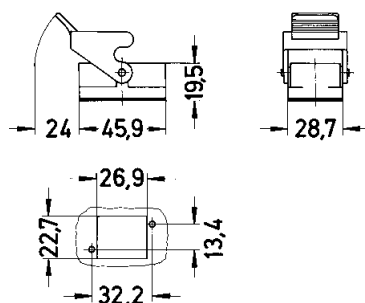

Gasket for housings
bulkhead mounting

Han® Q 8/0



09 12 000 9912

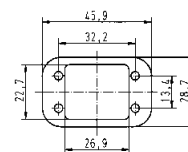

Housings,
surface mounting

Thermoplastic
angled
Cable gland order separately



09 12 008 0901

Pg 16

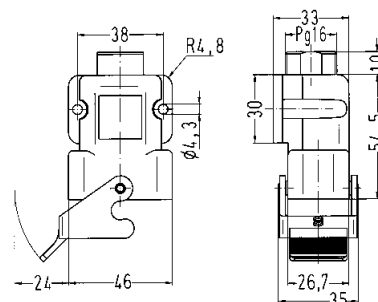

Hoods, cable to cable

Thermoplastic
Cable gland order separately



09 12 008 0727
19 12 008 0729

Pg 16
M 25

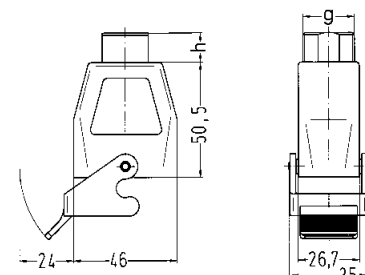

h	g
13	Pg 16
14	M 25x1.5

thermoplastic / metal

Identification

Part number

Drawing

Dimensions in mm

Housings

Cable seal

Thermoplastic
for housings
Thrust bolt and insert



09 00 000 5058

Pg 16

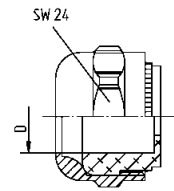

	cable	
	min.	max.
09 00 000 5058	11.5 mm	15.5 mm

Housings,
bulkhead mounting

Metal



black
chromated
09 12 008 0301

black
powder coated
09 12 708 0301

matt
nickel plated
09 12 008 0303

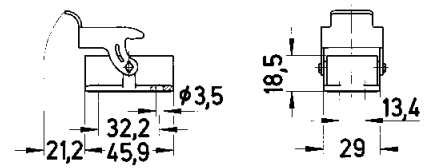

Han

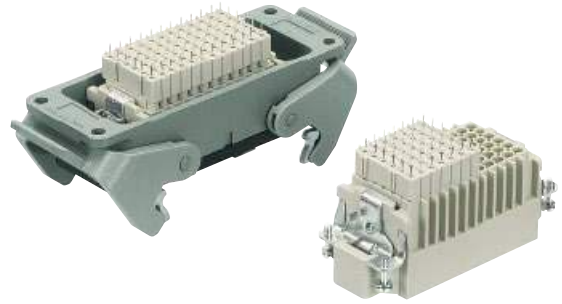

Han

Insert	Size	Part number		Drawing	Dimensions in mm															
		Male insert (M)	Female insert (F)																	
Order contacts separately					1) Distance for contact max. 21 mm <table border="1"> <thead> <tr> <th></th> <th>a</th> <th>b</th> </tr> </thead> <tbody> <tr> <td>24 DD</td> <td>44</td> <td>51</td> </tr> <tr> <td>42 DD</td> <td>57</td> <td>64</td> </tr> <tr> <td>72 DD</td> <td>77.5</td> <td>84.5</td> </tr> <tr> <td>108 DD</td> <td>104</td> <td>111</td> </tr> </tbody> </table>		a	b	24 DD	44	51	42 DD	57	64	72 DD	77.5	84.5	108 DD	104	111
	a	b																		
24 DD	44	51																		
42 DD	57	64																		
72 DD	77.5	84.5																		
108 DD	104	111																		
Han [®] 24 DD	6 B	09 16 024 3001	09 16 024 3101																	
Han [®] 42 DD	10 B	09 16 042 3001	09 16 042 3101																	
Han [®] 72 DD	16 B	09 16 072 3001	09 16 072 3101																	
Han [®] 108 DD	24 B	09 16 108 3001	09 16 108 3101																	

Han DD [®] double contacts	Part number		Drawing	Dimensions in mm
	Male contacts	Female contacts		
to connect the PCB-adapter				
	09 15 000 6191	09 15 000 6291		

Device side

PCB adapter	Part number		Drawing	Dimensions in mm						
	for PCBs up to 1.6 mm	for PCBs up to 2.4 mm								
				<table border="1"> <thead> <tr> <th></th> <th>a</th> </tr> </thead> <tbody> <tr> <td>09 16 000 9905</td> <td>2.6</td> </tr> <tr> <td>09 16 000 9908</td> <td>3.4</td> </tr> </tbody> </table>		a	09 16 000 9905	2.6	09 16 000 9908	3.4
	a									
09 16 000 9905	2.6									
09 16 000 9908	3.4									
		09 16 000 9905 09 16 000 9908								

Housing	Size	Part number		Drawing	Dimensions in mm																				
	6 B 10 B 16 B 24 B	09 30 006 0301 09 30 010 0301 09 30 016 0301 09 30 024 0301																							
				<table border="1"> <thead> <tr> <th>Size</th> <th>a</th> <th>b</th> <th>Panel cut out</th> </tr> </thead> <tbody> <tr> <td>6 B</td> <td>70</td> <td>80</td> <td>48 x 35</td> </tr> <tr> <td>10 B</td> <td>83</td> <td>93</td> <td>60 x 35</td> </tr> <tr> <td>16 B</td> <td>103</td> <td>113</td> <td>82 x 35</td> </tr> <tr> <td>24 B</td> <td>130</td> <td>140</td> <td>108 x 35</td> </tr> </tbody> </table>	Size	a	b	Panel cut out	6 B	70	80	48 x 35	10 B	83	93	60 x 35	16 B	103	113	82 x 35	24 B	130	140	108 x 35	Size 6 B with 1 locking lever
Size	a	b	Panel cut out																						
6 B	70	80	48 x 35																						
10 B	83	93	60 x 35																						
16 B	103	113	82 x 35																						
24 B	130	140	108 x 35																						

Cable side

Further informations see HARTING catalogue "Industrial Connectors Han[®], chapter DD"

Features

- ❑ Robust design
- ❑ Suitable for standard and EMC housing
- ❑ Low wiring costs
- ❑ Higher contact density

Technical characteristics

Approvals



Inserts

Number of contacts 24, 42, 72, 108

Electrical data acc. to DIN VDE 0627

7.5 A 250 V 4 kV 3

Working current
Working voltage
Rated impulse voltage
Pollution degree



Working voltage acc. to UL

250 V

Testing voltage U_{rms}
Insulation resistance

2 kV
 $\geq 10^{10} \Omega$

Material
Limiting temperatures

Polyamide

Flammability acc. to UL 94

HB

Mechanical working life

≥ 500

- Mating cycles
Wire gauge

0.14 - 2.5 mm²

Layout of printed circuit boards

Han[®] 24 DD

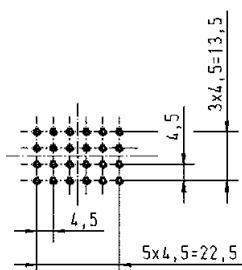

Han[®] 42 DD

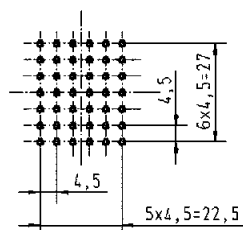

Han[®] 72 DD

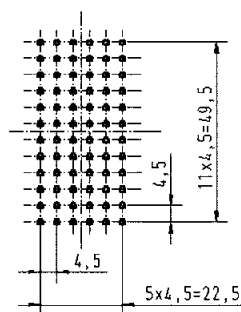

Han[®] 108 DD

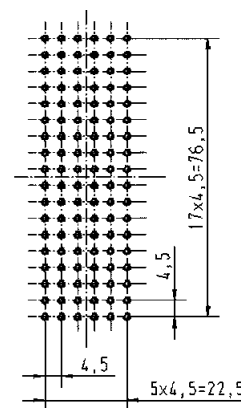

Recommended hole diameter: 0.8 mm

Assembly situation

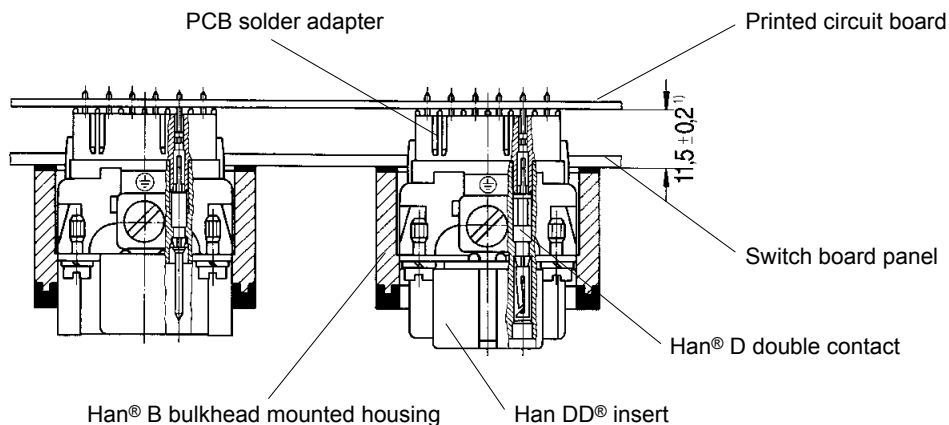

¹⁾ for Han[®] B EMC hoods/housings spacing of 12.5 ± 0.2 is necessary as no flange seal is used.



Han

Inserts	Size	Part number		Drawing	Dimensions in mm															
		Male insert (M)	Female insert (F)																	
Order contacts separately					<table border="1"> <thead> <tr> <th></th> <th>a</th> <th>b</th> </tr> </thead> <tbody> <tr> <td>6 E</td> <td>44</td> <td>51</td> </tr> <tr> <td>10 E</td> <td>57</td> <td>64</td> </tr> <tr> <td>16 E</td> <td>77.5</td> <td>84.5</td> </tr> <tr> <td>24 E</td> <td>104</td> <td>111</td> </tr> </tbody> </table>		a	b	6 E	44	51	10 E	57	64	16 E	77.5	84.5	24 E	104	111
	a	b																		
6 E	44	51																		
10 E	57	64																		
16 E	77.5	84.5																		
24 E	104	111																		
Han [®] 6 E	6 B	09 33 006 2602	09 33 006 2702																	
Han [®] 10 E	10 B	09 33 010 2602	09 33 010 2702																	
Han [®] 16 E	16 B	09 33 016 2602	09 33 016 2702																	
Han [®] 24 E	24 B	09 33 024 2602	09 33 024 2702																	

Han E [®] double contacts	Part number		Drawing	Dimensions in mm
	Male contacts	Female contacts		
to connect the PCB-adapter				
	09 33 000 6180	09 33 000 6280		

Device side

PCB adapter	Part number	Drawing	Dimensions in mm
	09 33 000 9996		

Housing	Size	Part number	Drawing	Dimensions in mm																				
	6 B 10 B 16 B 24 B	09 30 006 0301 09 30 010 0301 09 30 016 0301 09 30 024 0301		<table border="1"> <thead> <tr> <th>Size</th> <th>a</th> <th>b</th> <th>Panel cut out</th> </tr> </thead> <tbody> <tr> <td>6 B</td> <td>70</td> <td>80</td> <td>48 x 35</td> </tr> <tr> <td>10 B</td> <td>83</td> <td>93</td> <td>60 x 35</td> </tr> <tr> <td>16 B</td> <td>103</td> <td>113</td> <td>82 x 35</td> </tr> <tr> <td>24 B</td> <td>130</td> <td>140</td> <td>108 x 35</td> </tr> </tbody> </table> <p>Size 6 B with 1 locking lever</p>	Size	a	b	Panel cut out	6 B	70	80	48 x 35	10 B	83	93	60 x 35	16 B	103	113	82 x 35	24 B	130	140	108 x 35
Size	a	b	Panel cut out																					
6 B	70	80	48 x 35																					
10 B	83	93	60 x 35																					
16 B	103	113	82 x 35																					
24 B	130	140	108 x 35																					

Cable side

Further informations see HARTING catalogue "Industrial Connectors Han[®], chapter E"

Features

- ❑ Robust design
- ❑ Suitable for standard and EMC housings
- ❑ Low wiring costs
- ❑ Counter connector available with screw, crimp or cage clamp termination

Technical characteristics

Inserts

Number of contacts	6, 10, 16, 24
Electrical data acc. to DIN EN 61984	16 A 500 V 6 kV 3
Working current	
Working voltage	
Rated impulse voltage	
Pollution degree	
Insulation resistance	$\geq 10^{10} \Omega$
Material	Polycarbonate
Limiting temperatures	-40 °C / +125 °C
Flammability acc. to UL 94	V0
Mechanical working life	
- Mating cycles	≥ 500
Wire gauge	0.5 - 4 mm ²

Layout of printed circuit boards

Han[®] 6 E

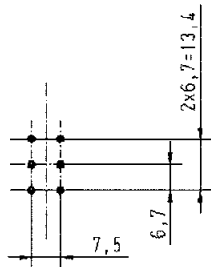

Han[®] 10 E

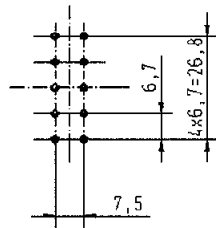

Han[®] 16 E

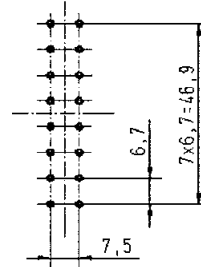

Han[®] 24 E

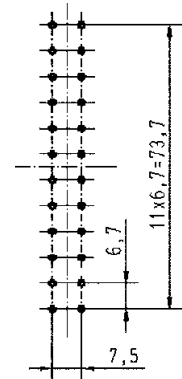

Recommended hole diameter: 1.8 mm

Assembly situation

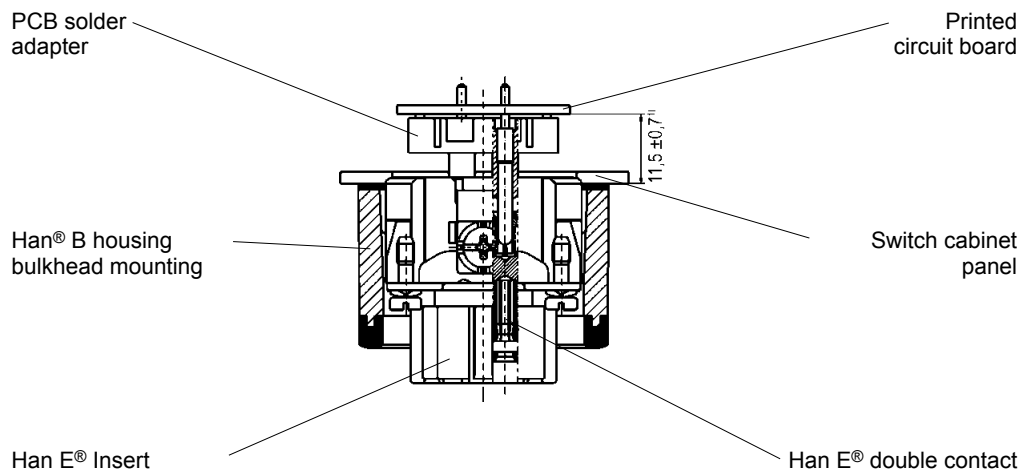

¹⁾ for Han[®] B EMC hoods/housings spacing of 12.5 ± 0.7 is necessary as no flange seal is used

Hinged frame	No. of modules	Part number		Size	Figure
		Male insert (M)	Female insert (F)		
	1	09 14 000 0304	09 14 000 0304	10 A	Drawings and further details see HARTING catalogue "Industrial Connectors Han®, chapter 06".
	2	09 14 006 0303	09 14 006 0313	6 B	
	3	09 14 010 0303	09 14 010 0313	10 B	
	4	09 14 016 0303	09 14 016 0313	16 B	
	5	09 14 024 0303	09 14 024 0313	24 B	
	6	09 14 024 0303	09 14 024 0313	24 B	

Identification	Part number		Drawing	Dimensions in mm						
	Male insert (M)	Female insert (F)								
Han DD® module PCB termination/ crimp termination 	09 14 012 3001	09 14 012 3101								
Han D® double contacts to connect the PCB 	09 15 000 6191	09 15 000 6291								
PCB adapter for PCBs up to 1.6 mm for PCBs up to 2.4 mm 	09 16 000 9905 09 16 000 9908		<table border="1" style="margin-left: auto; margin-right: auto;"> <thead> <tr> <th></th> <th>a</th> </tr> </thead> <tbody> <tr> <td>09 16 000 9905</td> <td>2.6</td> </tr> <tr> <td>09 16 000 9908</td> <td>3.4</td> </tr> </tbody> </table>		a	09 16 000 9905	2.6	09 16 000 9908	3.4	
	a									
09 16 000 9905	2.6									
09 16 000 9908	3.4									

Han® axial screw module	Part number		Drawing	Dimensions in mm
	Male insert (M)	Female insert (F)		
Axial screw termination Cable side 	09 14 002 2601	09 14 002 2701		
PCB adaption Device side 	09 14 002 2603	09 14 002 2703		
Solder contact 	09 32 000 6295			

Features

- ❑ Modular assembly
- ❑ Robust design
- ❑ Suitable for standard and EMC housings
- ❑ Low wiring costs

Technical characteristics

Han DD® module with PCB-adapter

Number of contacts	12
Working current	7.5 A
Working voltage	250 V
Wire gauge	0.14 - 2.5 mm ²

Han® axial screw module for PCB adaptations

Number of contacts	2
Working current	40 A
Working voltage	500 V
Wire gauge	2.5 - 10 mm ²

Layout of printed circuit boards

Depiction

Recommended hole diameter: 0.8 mm

Recommended hole diameter: 3.2 mm

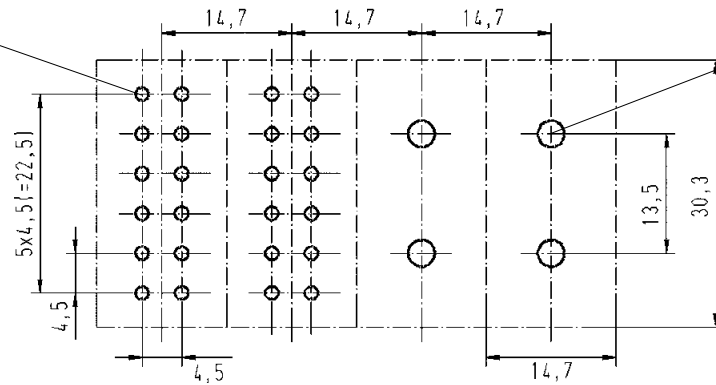

Han DD® module

Han® axial screw module 40 A

Assembly situation

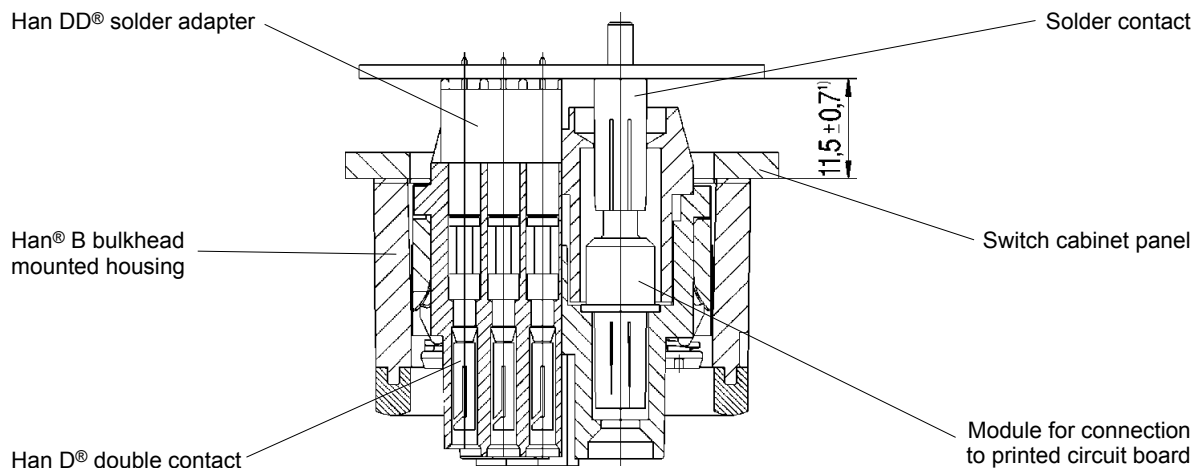

¹⁾ for Han® B EMC hoods/housings spacing of 12.5 ± 0.7 is necessary as no flange seal is used

- Secondary mating between industrial connector and printed circuit board.
- No higher force is applied on the soldering joint when mating the industrial connector due to an additional mating point.
- No wiring between printed circuit board and industrial connector necessary.
- thus no wiring faults
⇒ no testing, no costs
- Connecting times are minimized.
- Easy handling is time and cost saving.
- The production of mechanical and electrical / electronical components can be completely separated.
- Possibility to reach a higher degree of automation in the production (i. e. wave soldering of the PCBs).



Han DD® and Han® Q 5/0 PCB-adapter
Wilhelm Fette GmbH, Germany



Han E® PCB-adapter

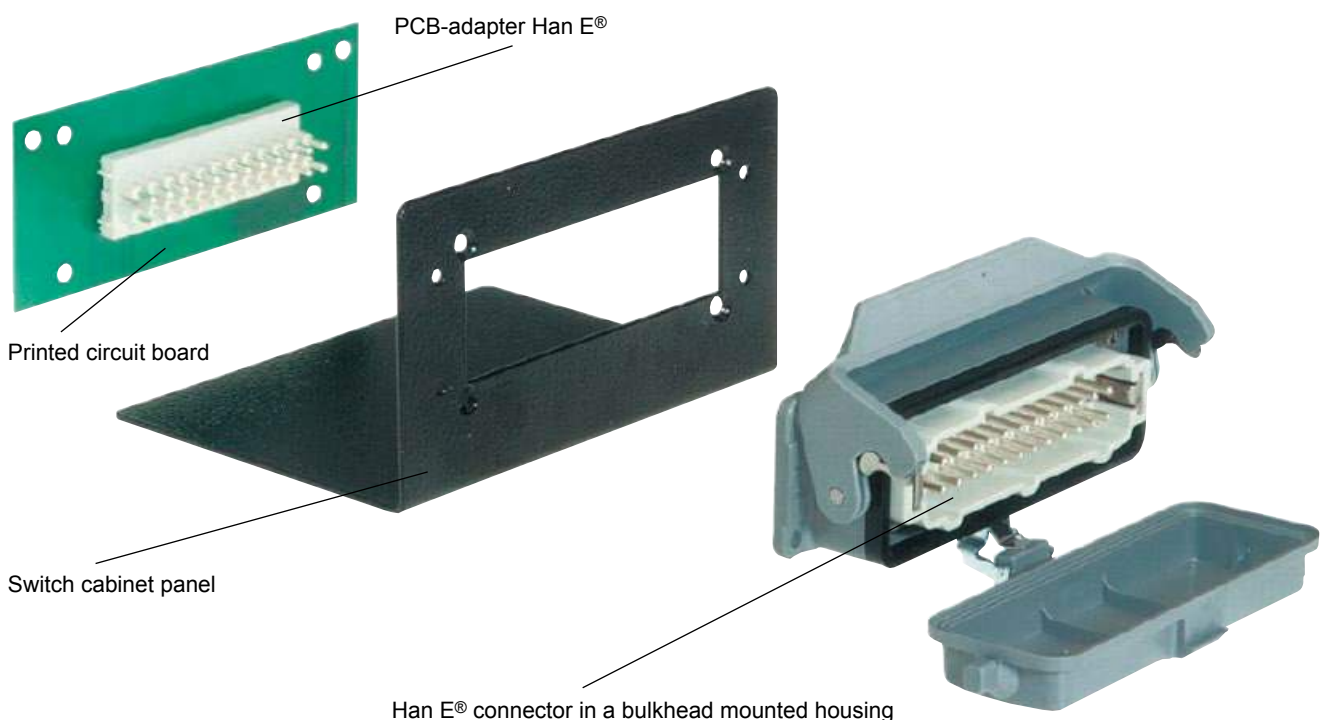

Han E® connector in a bulkhead mounted housing

05. Subminiature D Connectors

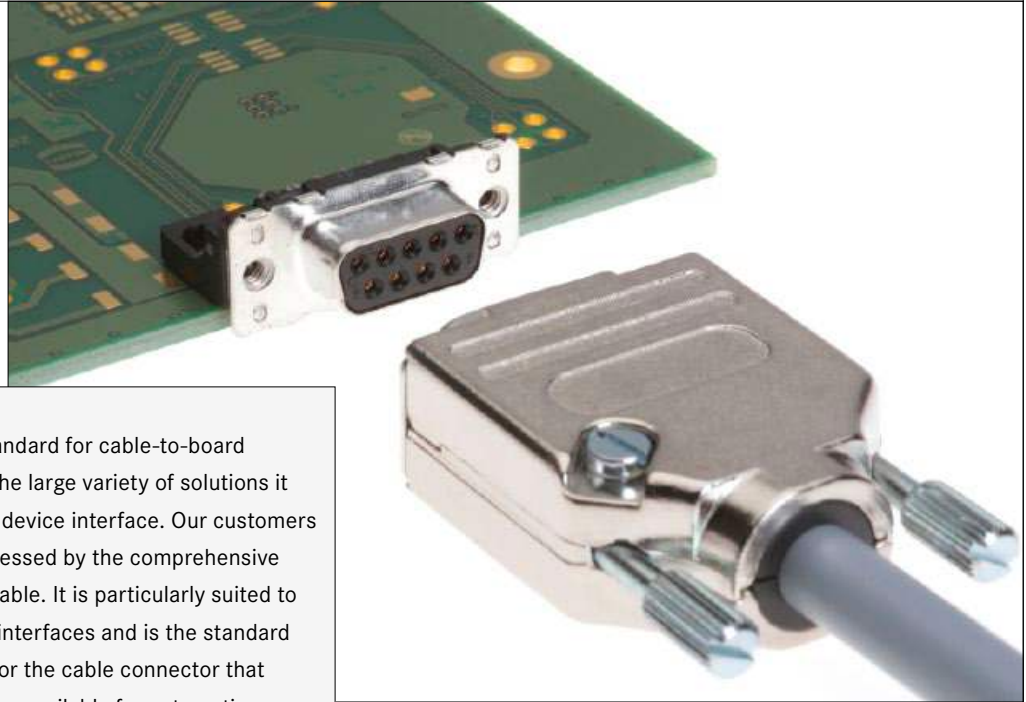

D-Sub connectors are an Industry Standard for cable-to-board connectivity applications. Thanks to the large variety of solutions it offers, it can be universally used as a device interface. Our customers manufacturing requirements are addressed by the comprehensive range of PCB termination styles available. It is particularly suited to configuring communication and data interfaces and is the standard for many fieldbus profiles. Solutions for the cable connector that can be easily assembled in the field are available for automation applications.

Application profile:

CONNECTION TYPE		ENVIRONMENT		APPLICATION						
Board to Board	Cable/Wire to Board	IP20	IP65 / IP67	Data	Signal	Power	high performance			
							Data transfer rate	Shielding	Number of contacts, contact density	Voltage, working current
Cable termination			PCB termination			Application standard				
<i>Han-Quick Lock®</i>	<i>IDC</i>	<i>Crimp</i>	<i>THT</i>	<i>SMC</i>	<i>SMT</i>	 				
<i>Screw</i>	<i>Cage clamp</i>	<i>Axial screw</i>	<i>Press-in</i>							
							Housing integration			
							<i>Separate housing</i>		<i>Integrated housing</i>	

Contents

	Page
D-Sub connector system – introduction	05.02
D-Sub Standard connectors (D-Sub – S)	05.04
D-Sub High Density connectors (D-Sub – HD)	05.38
D-Sub Mixed connectors (D-Sub – M)	05.50
D-Sub Filter connectors (D-Sub – F)	05.90
D-Sub Waterproof IP67 connectors (D-Sub – W)	05.116
D-Sub Housing range (D-Sub – H) and accessories	05.140
D-Sub Standard press-in connectors	05.171
D-Sub Standard SMC connectors	05.176
D-Sub Standard SMT connectors	05.184
Cables for insulation displacement termination and cable assemblies	05.194

05. Subminiature D Connectors



In the automation industry, the Subminiature D connectors are the standard interfaces for data, signal and service/programmer interfaces. The extensive HARTING product range allows the set up of all Subminiature D interfaces common in the industry, such as for field buses (PROFIBUS, CanOpen and DeviceNet), while the connectors are also available in optional plastic and metal housings with IP20 and IP65 / IP 67 protection.

In addition to the comprehensive range of Standard connectors with 9 to 50 straight, right-angled or US foot print style contacts, HARTING offers other product ranges which extend the application field of Subminiature D connectors considerably.

Depending on the product family, various termination techniques can be supplied such as press-in, solder, SMC or SMT to match the customer's termination process.

In addition, a wide range of hoods and accessories complete the cable connector range to fulfil all kinds of requirements such as EMC, IP65 / IP67 etc.

For the cabling HARTING provides cable assemblies for standard applications like fieldbus, cable or customized solutions.

D-Sub



D-SUB – MIXED CONNECTORS

with nearly 20 different contact arrangements offering versatile options for mixing power, coaxial, high voltage, signal and even pneumatic contacts in one connector.

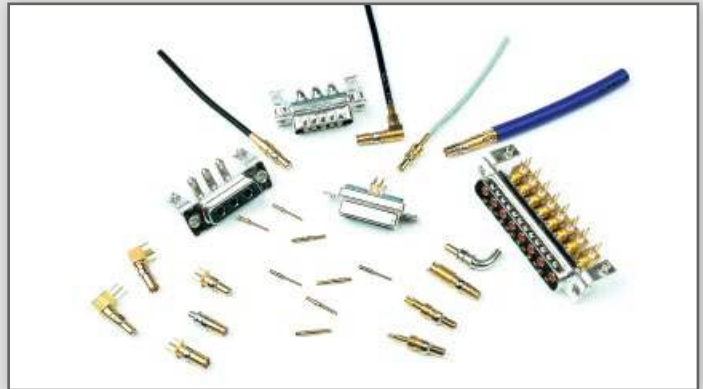

D-SUB – WATERPROOF

IP65 / IP67 connectors with 9 to 50 contacts for panel mount to PCB or cable.



D-SUB – FILTER CONNECTORS

with 9 to 37 contacts and integrated, different filter designs, like C, L or Pi types.



D-SUB – HIGH DENSITY CONNECTORS

with 15 to 78 straight and right-angled contacts, exceeding the contact capacity of the standard Subminiature D connectors by 70 %.



Number of contacts 9, 15, 25, 37, 50
UL recognized

Working current
see current carrying capacity chart
Turned contacts 7.5 A max.
Stamped contacts 6.5 A max.

Test voltage $U_{r.m.s.}$ 1 kV

Clearance and creepage ≥ 1.0 mm

Contact resistance ≤ 10 m Ω
Insulation resistance $\geq 10^{10}$ Ω

Temperature range -55 °C ... +125 °C
The higher temperature limit includes the local ambient and heating effect of the contacts under load

Terminations
a) Solder pins \varnothing 0.6 mm for P.C.B. holes \varnothing 0.8/1 mm
b) Solder pins, angled 90° \varnothing 0.6 mm for P.C.B. holes \varnothing 1 mm

Materials
Mouldings and hoods Thermoplastic resin, glass-fibre filled (PBTP), UL 94-V0

Contacts Copper alloy

Contact surface
Contact zone selectively plated according to performance level¹⁾

Metal shell Plated steel

Insertion and withdrawal force
Connector on P.C.B.
Solder, straight with clips
– insertion max. per connector: 60 N
– withdrawal min. per connector: 10 N

Mating force
9 way ≤ 30 N
15 way ≤ 50 N
25 way ≤ 83 N
37 way ≤ 123 N
50 way ≤ 167 N

Current carrying capacity

The current carrying capacity is limited by maximum temperature of materials for inserts and contacts including terminals. The current capacity-curve is valid for continuous, not interrupted current-loaded contacts of connectors when simultaneous power on all contacts is given, without exceeding the maximum temperature.

Control and test procedures according to DIN IEC 60512.

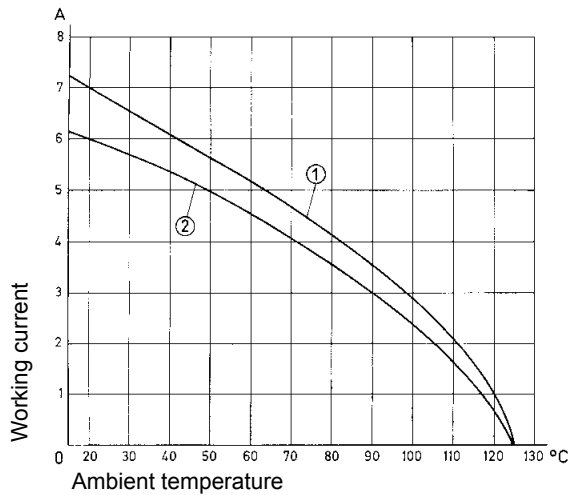

Example: 25 way connector

- ① Turned contacts
- ② Stamped contacts

Contact arrangement View from termination side

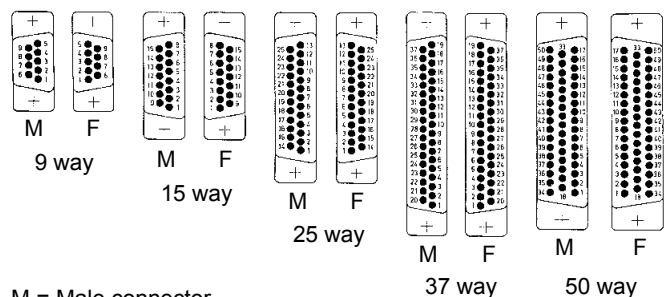

Mating conditions as per DIN 41652

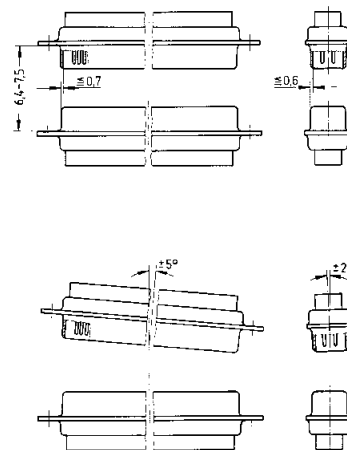

¹⁾ Performance level 3, 50 mating cycles, no gas test
Performance level 2 as per CECC 75301-802, 250 mating cycles, 4 days 4 mixed gas test – IEC 60512
Performance level 1 as per CECC 75301-802, 500 mating cycles, 10 days 4 mixed gas test – IEC 60512



A large grid of graph paper for taking notes. The grid is composed of 20 columns and 30 rows of small squares. The top row of the grid is a solid line, while the remaining rows are formed by dotted lines.

Number of contacts

9-50

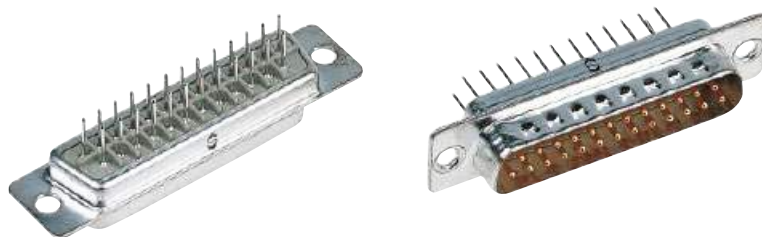

Turned solder pins, straight

Identification	No. of contacts	Part number	
Performance levels Explanations see page 05.04 Other performance levels on request		Performance level 3	Performance level 2
Male connector metal shell with dimples	9 15 25 37 50	09 67 009 5654 09 67 015 5654 09 67 025 5654 09 67 037 5654 09 67 050 5654 ¹⁾	09 67 009 5655 09 67 015 5655 09 67 025 5655 09 67 037 5655 09 67 050 5655 ¹⁾
Female connector metal shell	9 15 25 37 50	09 67 009 4754 09 67 015 4754 09 67 025 4754 09 67 037 4754 09 67 050 4754 ¹⁾	09 67 009 4755 09 67 015 4755 09 67 025 4755 09 67 037 4755 09 67 050 4755 ¹⁾

Male connector

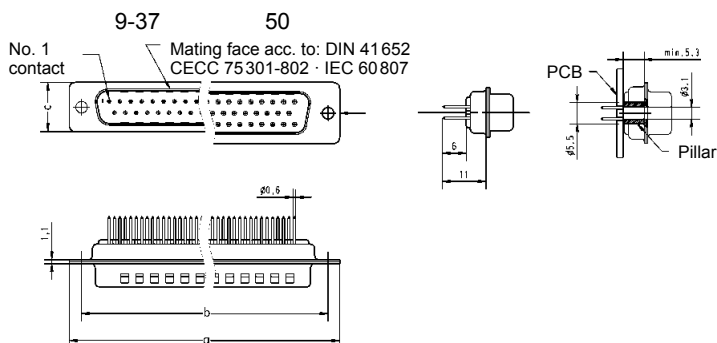

Female connector

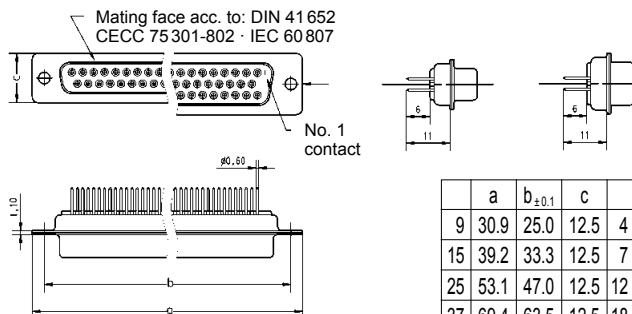

	a	b _{±0.1}	c	g	h
9	30.9	25.0	12.5	4 x 2.74 = 10.96	3 x 2.74 = 8.22
15	39.2	33.3	12.5	7 x 2.74 = 19.18	6 x 2.74 = 16.44
25	53.1	47.0	12.5	12 x 2.76 = 33.12	11 x 2.76 = 30.36
37	69.4	63.5	12.5	18 x 2.76 = 49.68	17 x 2.76 = 46.92
50	67.0	61.1	15.4	16 x 2.76 = 44.16	15 x 2.76 = 41.40

Board drillings

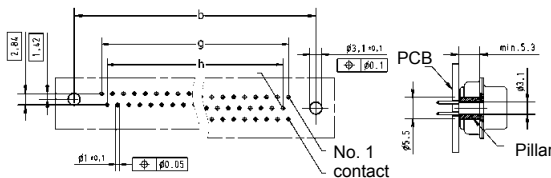

Dimensions in mm

¹⁾ Not normally kept in stock

Number of contacts

9-50



Turned solder pins, straight without grounding-pins

Identification	No. of contacts	Part number	
Performance levels Explanations see page 05.04 Other performance levels on request		Performance level 3	Performance level 2
Male connector metal shell with dimples available on request	9	09 66 121 770 .	09 66 121 670 .
	15	09 66 221 770 .	09 66 221 670 .
	25	09 66 321 770 .	09 66 321 670 .
	37	09 66 421 770 .	09 66 421 670 .
	50	09 66 521 770 .	09 66 521 670 .
Please insert digit for flange thread or fitted female screw locks	M3 ▶ 1 4-40 UNC ▶ 2 fitted screw locks 4-40 UNC ▶ 3		

D-Sub

Male connector

9-37 50

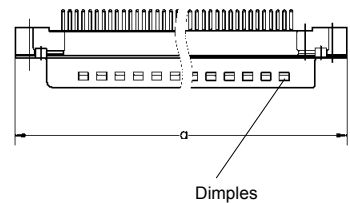
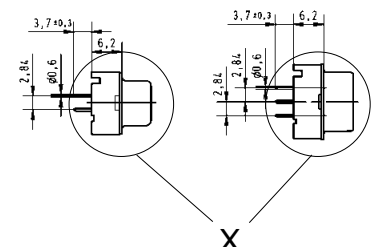
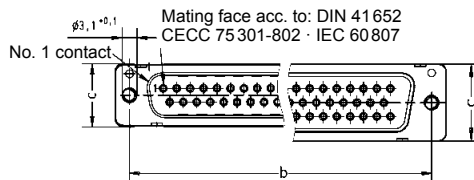

	a	b _{±0,1}	c	g	h
9	30.9	25.0	12.9	4 x 2.74 = 10.96	3 x 2.74 = 8.22
15	39.2	33.3	12.9	7 x 2.74 = 19.18	6 x 2.74 = 16.44
25	53.1	47.0	12.9	12 x 2.76 = 33.12	11 x 2.76 = 30.36
37	69.4	63.5	12.9	18 x 2.76 = 49.68	17 x 2.76 = 46.92
50	67.0	61.1	15.7	16 x 2.76 = 44.16	15 x 2.76 = 41.40

Board drillings

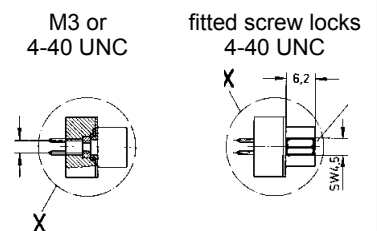
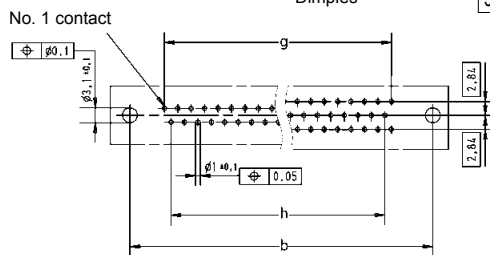

Dimensions in mm

Number of contacts

9-50



Stamped solder pins, straight with/without grounding board locks

D-Sub

Identification	No. of contacts	Part number	
Performance levels Explanations see page 05.04 Other performance levels on request		Performance level 3	Performance level 2
Male connector metal shell with dimples			
Without grounding board locks	9 15 25 37	09 65 121 770 . 09 65 221 770 . 09 65 321 770 . 09 65 421 770 .	09 65 121 670 . 09 65 221 670 . 09 65 321 670 . 09 65 421 670 .
With grounding board locks	9 15 25 37	09 65 161 771 . 09 65 261 771 . 09 65 361 771 . 09 65 461 771 .	09 65 161 671 . 09 65 261 671 . 09 65 361 671 . 09 65 461 671 .
Female connector metal shell			
Without grounding board locks	9 15 25 37 50	09 66 111 750 . 09 66 211 750 . 09 66 311 750 . 09 66 411 750 . 09 66 511 750 .	09 66 111 650 . 09 66 211 650 . 09 66 311 650 . 09 66 411 650 . 09 66 511 650 .
With grounding board locks	9 15 25 37	09 66 151 751 . 09 66 251 751 . 09 66 351 751 . 09 66 451 751 .	09 66 151 651 . 09 66 251 651 . 09 66 351 651 . 09 66 451 651 .
Please insert digit for flange thread or fitted female screw locks M3 1 4-40 UNC 2 fitted screw locks 4-40 UNC 3 ¹⁾			

¹⁾ Fitted screw locks 4-40 UNC not normally kept in stock for performance level 3
 Connector dimensions see page 05.09. Mating conditions see page 05.04.

Number of contacts

9-50



Stamped solder pins, straight with/without grounding board locks

Identification

Drawing

Dimensions in mm

Male connector
9 – 37 contacts

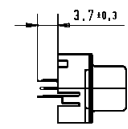
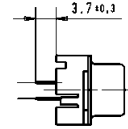
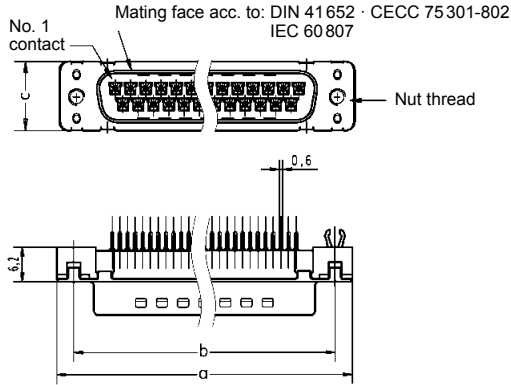

Female connector
9 – 37 contacts

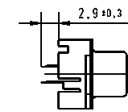
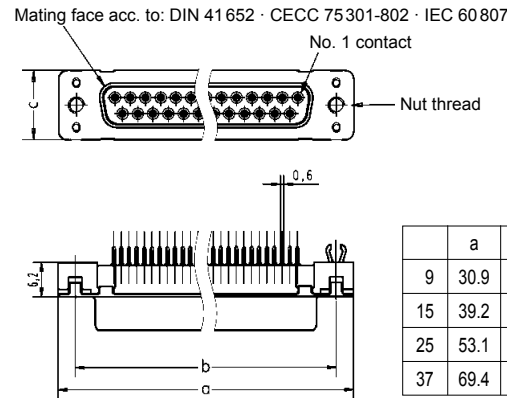

	a	b _{±0.1}	c	g	h
9	30.9	25.0	12.5	4 x 2.74 = 10.96	3 x 2.74 = 8.22
15	39.2	33.3	12.5	7 x 2.74 = 19.18	6 x 2.74 = 16.44
25	53.1	47.0	12.5	12 x 2.76 = 33.12	11 x 2.76 = 30.36
37	69.4	63.5	12.5	18 x 2.76 = 49.68	17 x 2.76 = 46.92

Board drillings
9 – 37 contacts

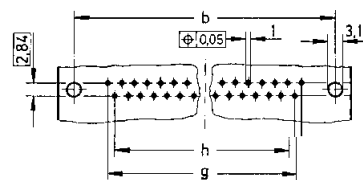

D-Sub

Front panel width 3 TE
3 x 5.08 mm

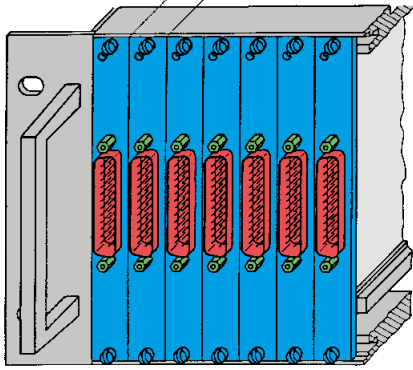

Low-Profile Versions
pages 05.18 – 05.21

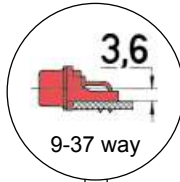

Front panel width 4 TE
4 x 5.08 mm

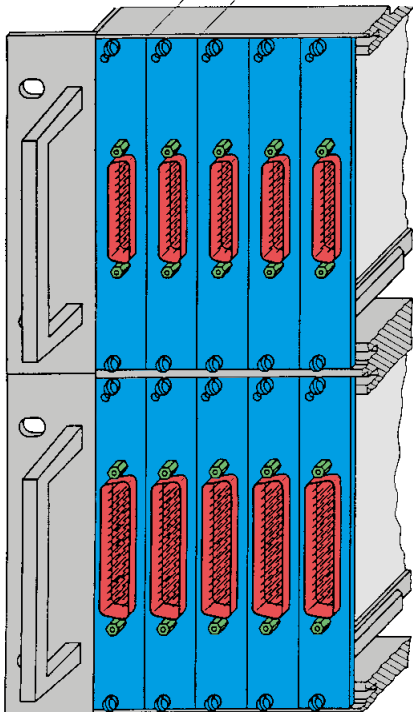

Standard Versions
pages 05.12 – 05.17

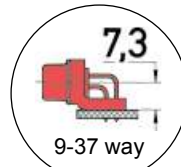

U.S. Footprint Versions
pages 05.22 – 05.23

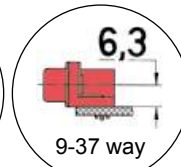

Front panel width 5 TE
5 x 5.08 mm

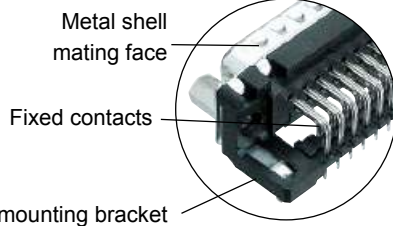
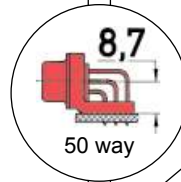
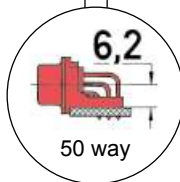
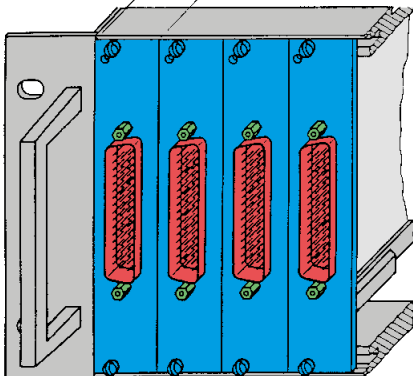

Advantages

All-round protective metal shell

- Polarisation
- Contact protection
- Plated shell
- Male connector with dimples

Plated terminations for increased solderability

Grounding contact riveted to metal shell

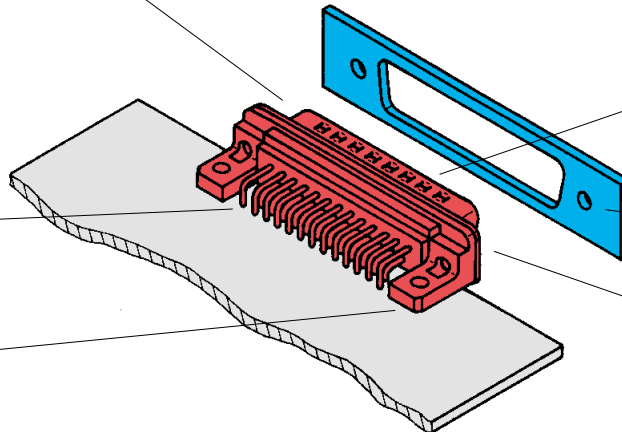

Contact surface finish to different performance levels

Panel

Different metal threads possible in flange area

- M3
- 4-40 UNC
- fitted female screw locks 4-40 UNC
- max. torque ≤ 0.8 Nm

Integrated plastic mounting bracket

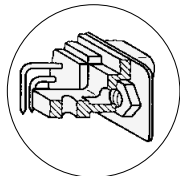

Mounting bracket

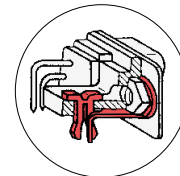

Mounting bracket with snap-in-clips and grounding pin

Mounting height

Low-Profile Versions

The reduced mounting height of these connectors allow them to be used on the same PCB as DIN 41612

types with no loss of packaging density when card frames to DIN 41494 are used.

9-37 way connectors with 3.6 mm mounting height can be fitted to front panels of 3 TE (15.24 mm) width.

50 way connectors with 6.2 mm mounting height can be fitted to front panels of 4 TE (20.32 mm) width.

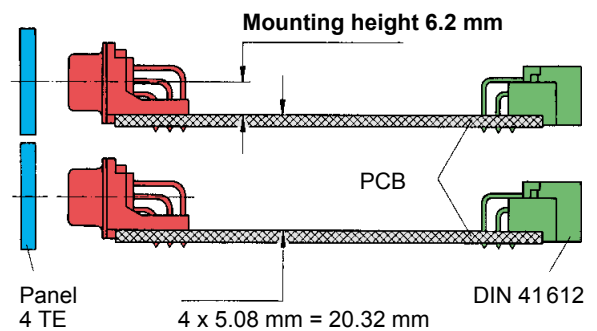
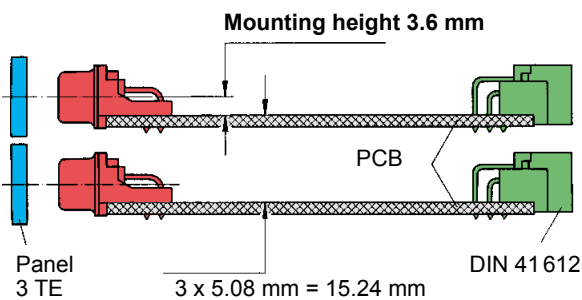

Standard Versions US Footprint

9-37 way connectors with 7.3 mm mounting height can be fitted to front panels of 4 TE (20.32 mm) width.

50 way connectors with 8.7 mm mounting height can be fitted to front panels of 5 TE (25.4 mm) width.

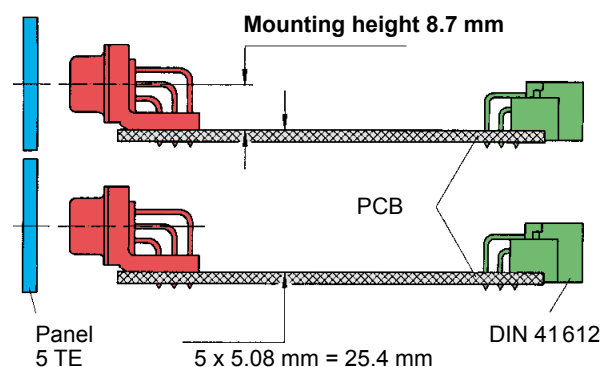
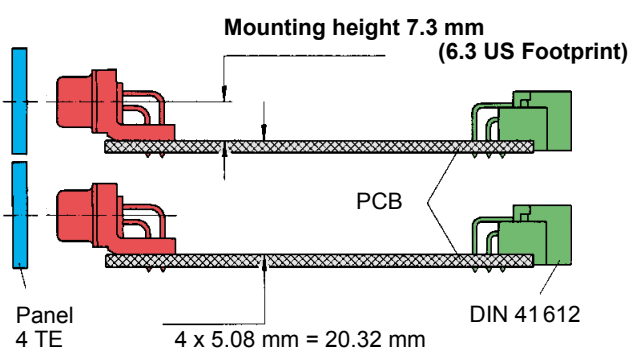

Number of contacts

Mounting height

9–37
50

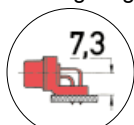

Standard Versions

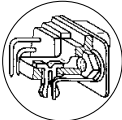
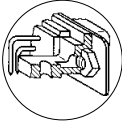

Turned solder pins, angled with/without snap-in-clips and grounding board locks

Identification	No. of contacts	Part number	
Performance levels Explanations see page 05.04 Other performance levels on request		Performance level 3	Performance level 2
Male connector metal shell with dimples With snap-in clips and grounding board locks 	9 15 25 37 50	2.84 mm pitch 09 66 163 781 . 09 66 263 781 . 09 66 363 781 . 09 66 463 781 . 09 66 563 781 . 2.54 mm pitch 09 66 162 781 . 09 66 262 781 . 09 66 362 781 . 09 66 462 781 . 09 66 562 781 .	2.84 mm pitch 09 66 163 681 . 09 66 263 681 . 09 66 363 681 . 09 66 463 681 . 09 66 563 681 . 2.54 mm pitch 09 66 162 681 . 09 66 262 681 . 09 66 362 681 . 09 66 462 681 . 09 66 562 681 .
Without snap-in clips and grounding board locks 	9 15 25 37 50	2.84 mm pitch 09 66 123 780 . 09 66 223 780 . 09 66 323 780 . 09 66 423 780 . 09 66 523 780 . 2.54 mm pitch 09 66 122 780 . 09 66 222 780 . 09 66 322 780 . 09 66 422 780 . 09 66 522 780 .	2.84 mm pitch 09 66 123 680 . 09 66 223 680 . 09 66 323 680 . 09 66 423 680 . 09 66 523 680 . 2.54 mm pitch 09 66 122 680 . 09 66 222 680 . 09 66 322 680 . 09 66 422 680 . 09 66 522 680 .
Please insert digit for flange thread or fitted female screw locks M3 ▶ 1 4-40 UNC ▶ 2 fitted screw locks 4-40 UNC ▶ 3			

available on request

available on request

Number of contacts

9-37
50

Mounting height

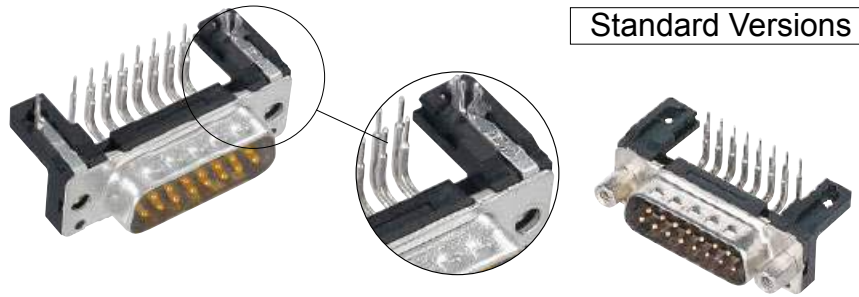

Standard Versions

Turned solder pins, angled with/without snap-in-clips and grounding board locks

Identification

Drawing

Dimensions in mm

Male connector

With snap-in clips and grounding board locks

9-37 50
Mating face acc. to: DIN 41652 · CECC 75301-802 · IEC 60807
No. 1 contact

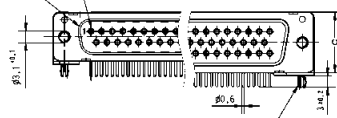

Grounding pins 0.2 x 0.6

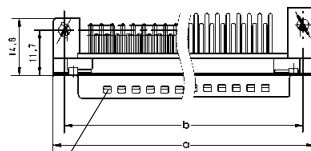

Dimples

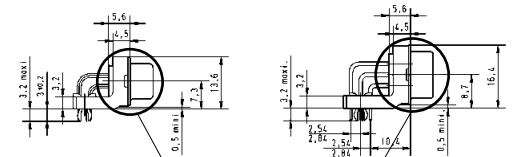

fitted screw locks
4 - 40 UNC

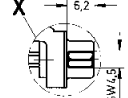

M3 or
4 - 40 UNC

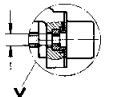

Without snap-in clips and grounding board locks

9-37 50
Mating face acc. to: DIN 41652 · CECC 75301-802 · IEC 60807
No. 1 contact

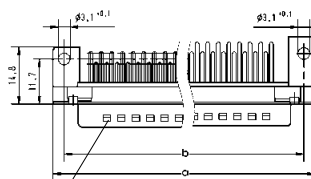
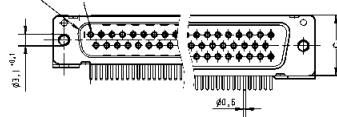

Dimples

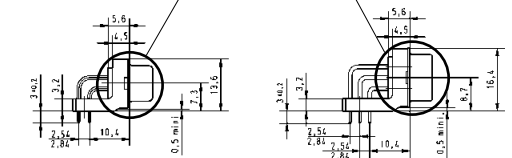

Board drillings

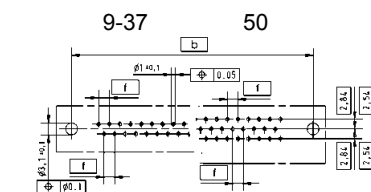

	a	b \pm 0.1	c	f
9	30.90	25.00	12.90	2.74
15	39.20	33.30	12.90	2.74
25	53.10	47.00	12.90	2.76
37	69.40	63.50	12.90	2.76
50	67.00	61.10	15.70	2.76

Number of contacts

Mounting height

9–37
50

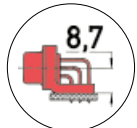

Standard Versions

Stamped solder pins, angled with grounding board locks

Identification	No. of contacts	Part number		
		Performance level 3	Performance level 2	
Performance levels Explanations see page 05.04 Other performance levels on request				
Male connector metal shell with dimples		2.84 mm pitch	2.84 mm pitch	
	9	09 65 163 781 . 1)	09 65 163 681 . 1)	
	15	09 65 263 781 . 1)	09 65 263 681 . 1)	
	25	09 65 363 781 . 1)	09 65 363 681 . 1)	
	37	09 65 463 781 . 1)	09 65 463 681 . 1)	
		2.54 mm pitch	2.54 mm pitch	
	9	09 65 162 781 .	09 65 162 681 .	
	15	09 65 262 781 .	09 65 262 681 .	
	25	09 65 362 781 .	09 65 362 681 .	
	37	09 65 462 781 .	09 65 462 681 .	
	Female connector metal shell		2.84 mm pitch	2.84 mm pitch
		9	09 66 153 761 . 1)	09 66 153 661 . 1)
		15	09 66 253 761 . 1)	09 66 253 661 . 1)
		25	09 66 353 761 . 1)	09 66 353 661 . 1)
37		09 66 453 761 . 1)	09 66 453 661 . 1)	
		2.54 mm pitch	2.54 mm pitch	
9		09 66 152 761 .	09 66 152 661 .	
15		09 66 252 761 .	09 66 252 661 .	
25		09 66 352 761 .	09 66 352 661 .	
37		09 66 452 761 .	09 66 452 661 .	
50		09 66 552 761 . 1)	09 66 552 661 . 1)	
Please insert digit for flange thread or fitted female screw locks				
		Ø 3.1 mm hole ▶	0 ¹⁾	
		M3 ▶	1	
	4-40 UNC ▶	2		
fitted screw locks 4-40 UNC ▶	3			

D-Sub

¹⁾ Not normally kept in stock

Number of contacts

Mounting height

Standard Versions

9-37
50

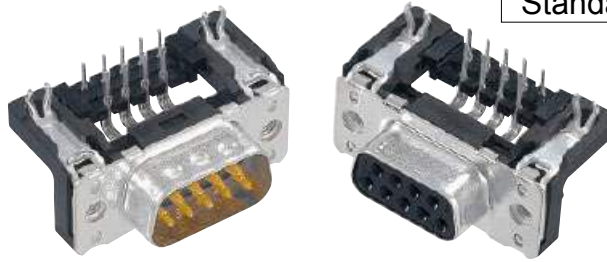
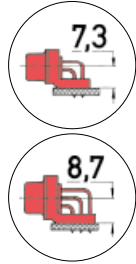

Stamped solder pins, angled with grounding board locks

Identification

Drawing

Dimensions in mm

Male connector

Mating face acc. to: DIN 41652 · CECC 75301-802
IEC 60807

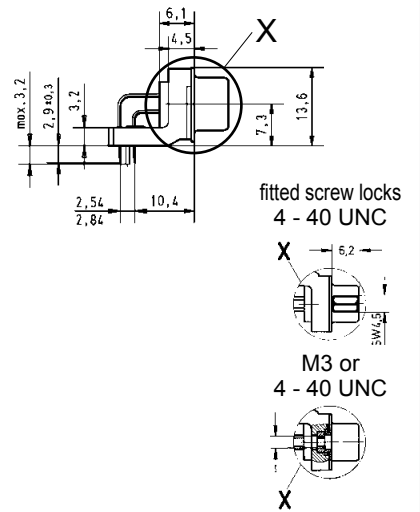
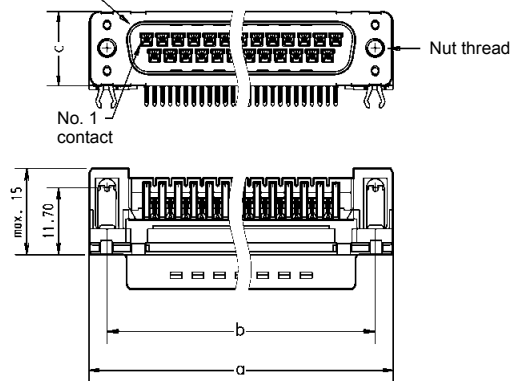

Female connector

9-37 50

Mating face acc. to: DIN 41652 · CECC 75301-802
IEC 60807

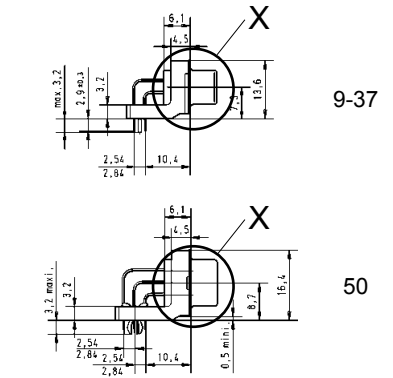
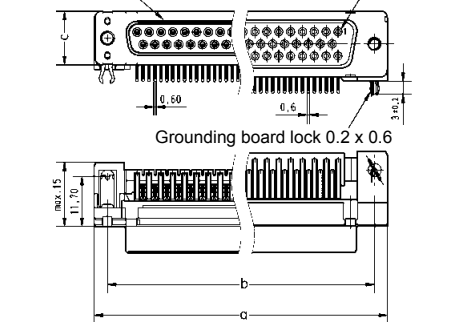

Board drillings

9-37 50

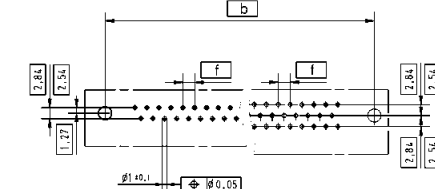

	a	b±0.1	c	f
9	30.90	25.00	12.50	2.74
15	39.20	33.30	12.50	2.74
25	53.10	47.00	12.50	2.76
37	69.40	63.50	12.50	2.76
50	67.00	61.10	15.40	2.76

Number of contacts

Mounting height

Standard Versions

9-37
50

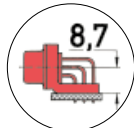
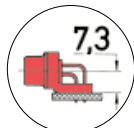

Stamped solder pins, angled without grounding board locks

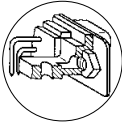
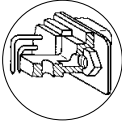
Identification	No. of contacts	Part number	
Performance levels Explanations see page 05.04 Other performance levels on request		Performance level 3	Performance level 2
Male connector metal shell with dimples 	9	09 65 123 780 . 1)	09 65 123 680 . 1)
	15	09 65 223 780 . 1)	09 65 223 680 . 1)
Female connector metal shell 	25	09 65 323 780 . 1)	09 65 323 680 . 1)
	37	09 65 423 780 . 1)	09 65 423 680 . 1)
Please insert digit for flange thread or fitted female screw locks	Ø 3.1 mm hole ▶ 0 ¹⁾ M3 ▶ 1 4-40 UNC ▶ 2 fitted screw locks 4-40 UNC ▶ 3		

D-Sub

¹⁾ Not normally kept in stock

Number of contacts

Mounting height

Standard Versions

9-37
50

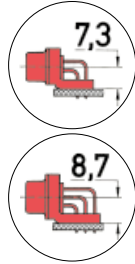

Stamped solder pins, angled without grounding board locks

Identification

Drawing

Dimensions in mm

Male connector

Mating face acc. to: DIN 41652 · CECC 75301-802 · IEC 60807

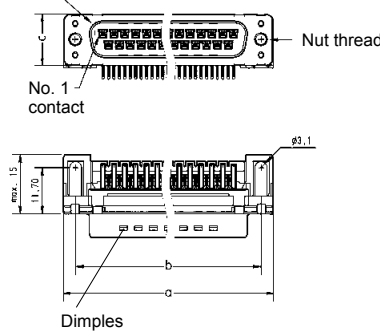

fitted screw locks
4 - 40 UNC

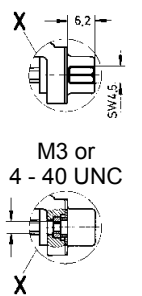

Female connector

9-37 50
Mating face acc. to: DIN 41652 · CECC 75301-802 · IEC 60807
No. 1 contact

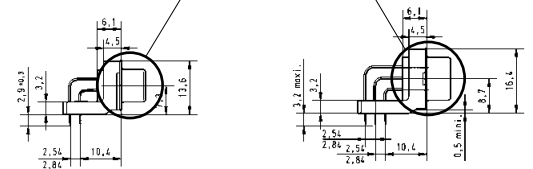
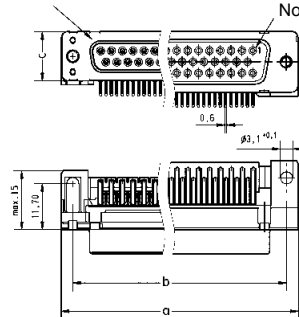

Board drillings

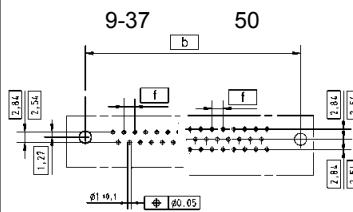

	a	b ± 0.1	c	f
9	30.90	25.00	12.50	2.74
15	39.20	33.30	12.50	2.74
25	53.10	47.00	12.50	2.76
37	69.40	63.50	12.50	2.76
50	67.00	61.10	15.40	2.76

D-Sub

Number of contacts

Mounting height

Low-Profile Versions

9–37
50

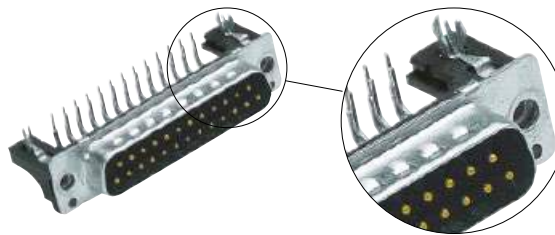
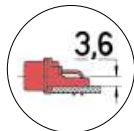

Turned solder pins, angled with snap-in-clips and grounding board locks

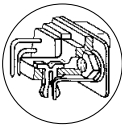
Identification	No. of contacts	Part number	
<p>Performance levels Explanations see page 05.04 Other performance levels on request</p>		<p>Performance level 3</p>	<p>Performance level 2</p>
<p>Male connector metal shell with dimples</p>  <p>available on request</p>	<p>9 15 25 37 50</p>	<p>2.54 mm pitch</p> <p>09 66 162 781 . 09 66 262 781 . 09 66 362 781 . 09 66 462 781 . 09 66 562 781 .</p>	<p>2.54 mm pitch</p> <p>09 66 162 681 . 09 66 262 681 . 09 66 362 681 . 09 66 462 681 . 09 66 562 681 .</p>
<p>Please insert digit for flange thread or fitted female screw locks</p> <p>M3 ▶ 5 4-40 UNC ▶ 6 fitted screw locks 4-40 UNC ▶ 7</p>			

D-Sub

Number of contacts

Mounting height

Low-Profile Versions

9-37
50

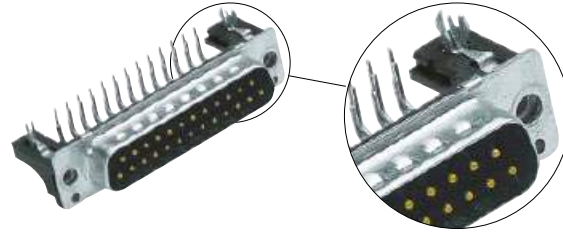

Turned solder pins, angled with snap-in-clips and grounding board locks

Identification

Drawing

Dimensions in mm

Male connector

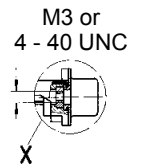
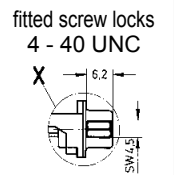
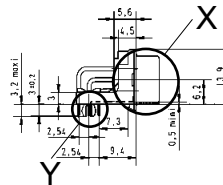
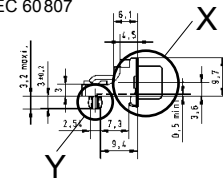
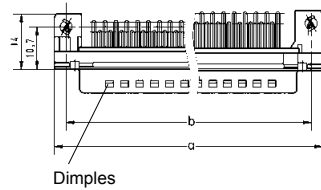
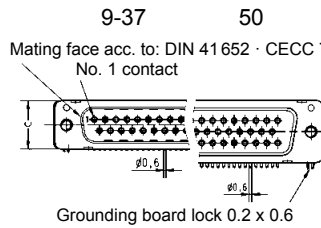

Board drillings

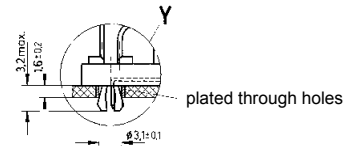
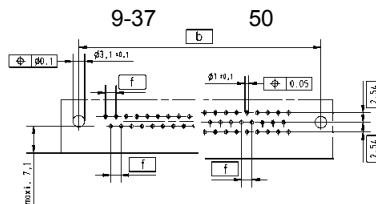

	a	b±0.1	c	f
9	30.90	25.00	12.50	2.74
15	39.20	33.30	12.50	2.74
25	53.10	47.00	12.50	2.76
37	69.40	63.50	12.50	2.76
50	67.00	61.10	15.70	2.76

D-Sub

Number of contacts

Mounting height

9–37
50

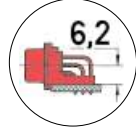
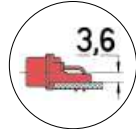

Low-Profile Versions

Stamped solder pins, angled with grounding board locks

Identification	No. of contacts	Part number	
		Performance level 3	Performance level 2
Performance levels Explanations see page 05.04 Other contact surfaces on request			
Male connector metal shell with dimples	9 15 25 37	09 65 162 781 . 09 65 262 781 . 09 65 362 781 . 09 65 462 781 .	09 65 162 681 . 09 65 262 681 . 09 65 362 681 . 09 65 462 681 .
Female connector metal shell	9 15 25 37 50	09 66 152 761 . 09 66 252 761 . 09 66 352 761 . 09 66 452 761 . 09 66 552 761 . ¹⁾	09 66 152 661 . 09 66 252 661 . 09 66 352 661 . 09 66 452 661 . 09 66 552 661 . ¹⁾
Please insert digit for flange thread or fitted female screw locks	M3 ▶ 5 4-40 UNC ▶ 6 fitted screw locks 4-40 UNC ▶ 7		

D-Sub

¹⁾ Not normally kept in stock

Number of contacts

Mounting height

9-37
50

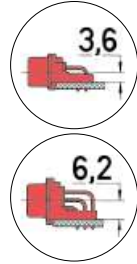

Low-Profile Versions

Stamped solder pins, angled with grounding board locks

Identification

Drawing

Dimensions in mm

Male connector

Mating face acc. to: DIN 41652 · CECC 75301-802
IEC 60807

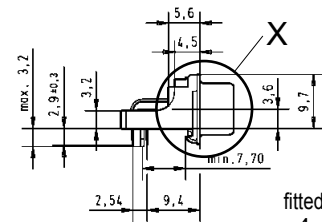
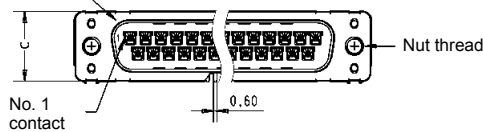

fitted screw locks
4 - 40 UNC

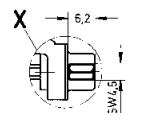

M3 or
4 - 40 UNC

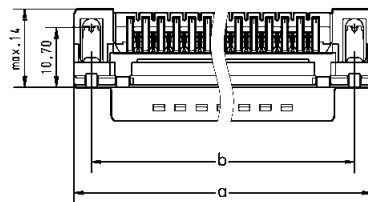
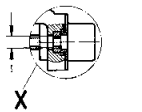

9-37 50

Female connector

Mating face acc. to: DIN 41652 · CECC 75301-802
IEC 60807

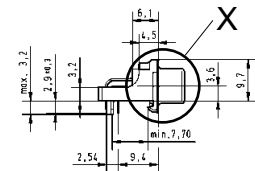
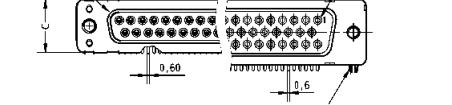

9-37

Grounding board lock 0.2 x 0.6

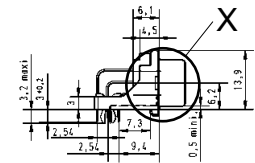
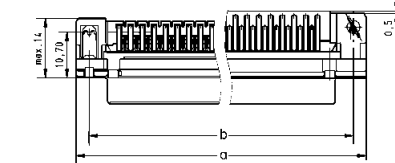

50

Board drillings

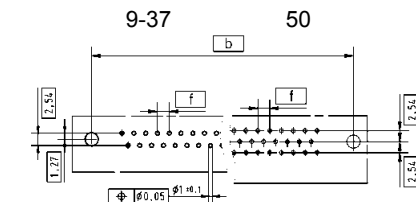

	a	b±0.1	c	f
9	30.90	25.00	12.50	2.74
15	39.20	33.30	12.50	2.74
25	53.10	47.00	12.50	2.76
37	69.40	63.50	12.50	2.76
50	67.00	61.10	15.40	2.76

U.S. Footprint

Number of contacts

Mounting height

9–37

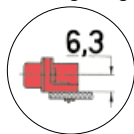

Stamped solder pins, angled with snap-in-clips and grounding board locks

Identification	No. of contacts	Part number	
Performance levels Explanations see page 05.04 Other performance levels on request		Performance level 3	
Male connector metal shell with dimples	9 15 25 37	2.84 mm pitch 09 68 163 781 . 09 68 263 781 . 09 68 363 781 . 09 68 463 781 .	S4 ¹⁾ 2.84 mm pitch 09 68 163 581 . 09 68 263 581 . 09 68 363 581 . 09 68 463 581 .
Female connector metal shell	9 15 25 37	2.84 mm pitch 09 68 153 761 . 09 68 253 761 . 09 68 353 761 . 09 68 453 761 .	2.84 mm pitch 09 68 153 561 . 09 68 253 561 . 09 68 353 561 . 09 68 453 561 .
Please insert digit for flange thread or fitted female screw locks		M3 ▶ 1 ²⁾ 4-40 UNC ▶ 2 fitted screw locks 4-40 UNC ▶ 3	

D-Sub

¹⁾ S4 = 0.76 µm (30 µinch) Au or PdNi equivalent
²⁾ Not normally kept in stock

U.S. Footprint

Number of contacts

Mounting height

9-37



Stamped solder pins, angled with snap-in-clips and grounding board locks

Identification

Drawing

Dimensions in mm

Male connector

Mating face acc. to: DIN 41 652 · CECC 75 301-802
IEC 60 807

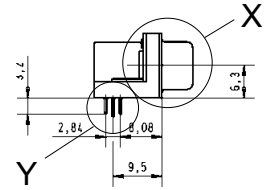
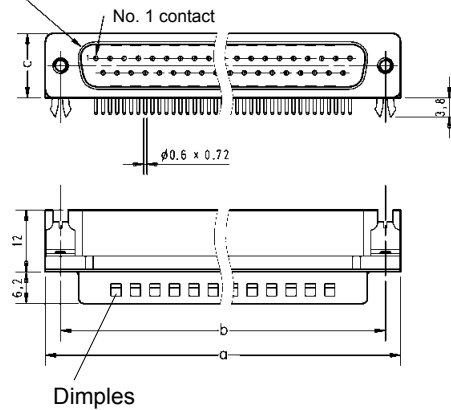

plated through holes

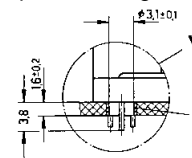

Female connector

Mating face acc. to: DIN 41 652 · CECC 75 301-802
IEC 60 807

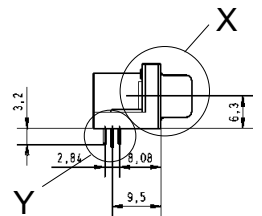
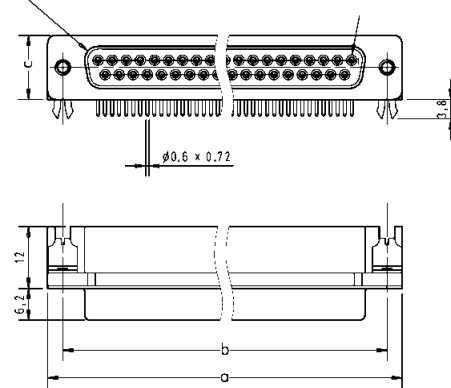

M3 or 4 - 40 UNC fitted screw locks
4 - 40 UNC

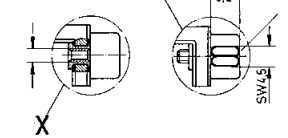

Board drillings

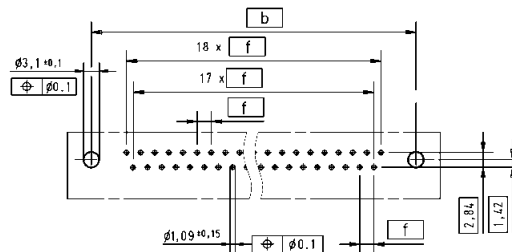

	a	b ± 0.1	c	f
9	30.90	25.00	12.55	2.77
15	39.20	33.30	12.55	2.77
25	53.10	47.00	12.55	2.77
37	69.40	63.50	12.55	2.77

D-Sub

Identification

Drawing

Dimensions in mm

Standard Versions

Mounting height 7.3 mm
9-37 way
for front panel
4 units of width (TE)

Mounting height 8.7 mm
50 way
for front panel
5 units of width (TE)

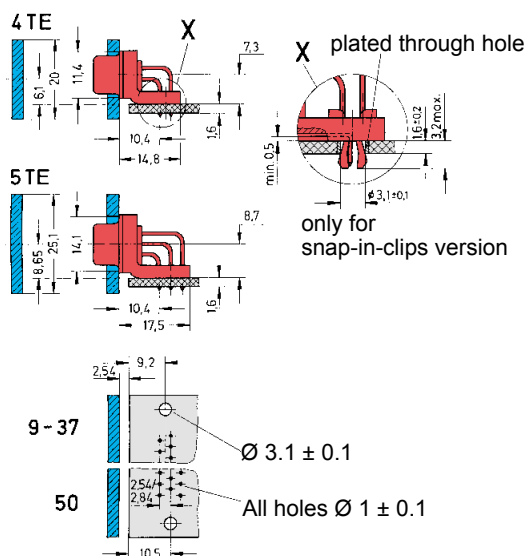

for connectors see pages 05.12 – 05.17

Low-Profile Versions

Mounting height 3.6 mm
9-37 way
for front panel
3 units of width (TE)

Mounting height 6.2 mm
50 way
for front panel
4 units of width (TE)

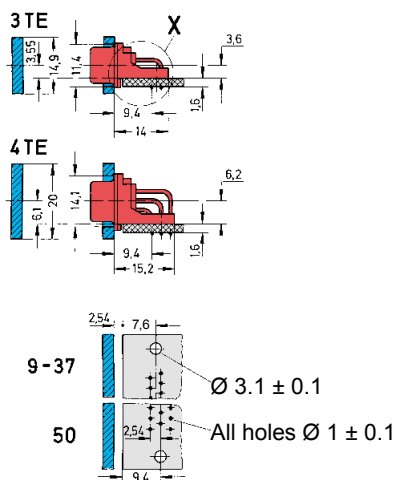

When used in a wave soldering process the mating face of the connector must be protected with adhesive tape.



for connectors see pages 05.18 – 05.21

U.S. Footprint Versions

Mounting height 6.3 mm
9-37 way
for front panel
4 units of width (TE)

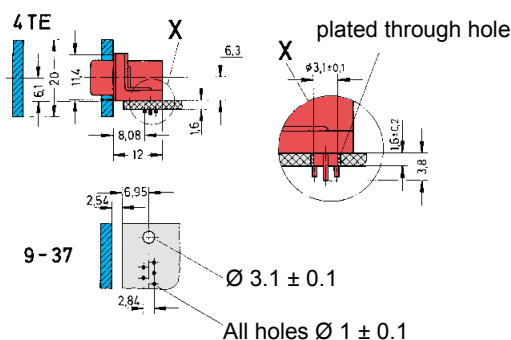

for connectors see pages 05.22 – 05.23

Panel cut out for front/rear mount

Values are taken from the CECC 75301-802

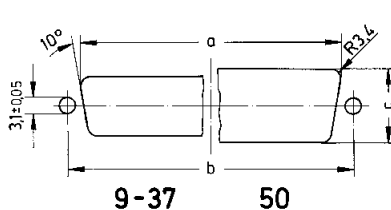

Front mount

	a ± 0.2	b ± 0.13	c ± 0.2
9	22.2	25.0	12.3
15	30.5	33.3	12.3
25	44.3	47.0	12.3
37	60.7	63.5	12.3
50	58.3	61.1	15.1

Rear mount

	a ± 0.2	b ± 0.13	c ± 0.2
9	20.5	25.0	11.4
15	28.8	33.3	11.4
25	42.5	47.0	11.4
37	59.1	63.5	11.4
50	56.3	61.1	14.1

Number of contacts 9, 15, 25, 37, 50
UL recognized

Working current
see current carrying capacity chart
Turned contacts 7.5 A max.
Stamped contacts 6.5 A max.
Insulation displacement 2 A max.

Test voltage $U_{r.m.s.}$ 1 kV

Clearance and creepage ≥ 1.0 mm
 ≥ 0.7 mm (insulation displacement)

Contact resistance ≤ 10 m Ω
Insulation resistance $\geq 10^{10}$ Ω

Temperature range
turned version -55 °C ... + 125 °C
stamped solder bucket version -40 °C ... + 85 °C

Terminations

- a) Solder buckets
AWG 20
- b) Stamped crimp contacts
AWG 28-24
0.09-0.25 mm²
max. insulation \varnothing 1.02 mm
AWG 24-20
0.25-0.56 mm²
max. insulation \varnothing 1.52 mm
- c) Turned crimp contacts
AWG 22-18
0.33-0.82 mm²
AWG 24-20
0.25-0.52 mm²
AWG 26-22
0.13-0.33 mm²
AWG 28-24
0.09-0.25 mm²
max. insulation \varnothing 2.15 mm
- d) Insulation displacement
AWG 28/7 and AWG 26/7

Materials

- Mouldings and hoods Thermoplastic resin, glass-fibre filled (PBTP), UL 94-V0
- Contacts Copper alloy
- Contact surface
Contact zone selectively plated according to performance level¹⁾
- Metal shell Plated steel

Mating force

- 9 way ≤ 30 N
- 15 way ≤ 50 N
- 25 way ≤ 83 N
- 37 way ≤ 123 N
- 50 way ≤ 167 N

Current carrying capacity

The current carrying capacity is limited by maximum temperature of materials for inserts and contacts including terminals. The current capacity-curve is valid for continuous, not interrupted current-loaded contacts of connectors when simultaneous power on all contacts is given, without exceeding the maximum temperature. Control and test procedures according to DIN IEC 60512.

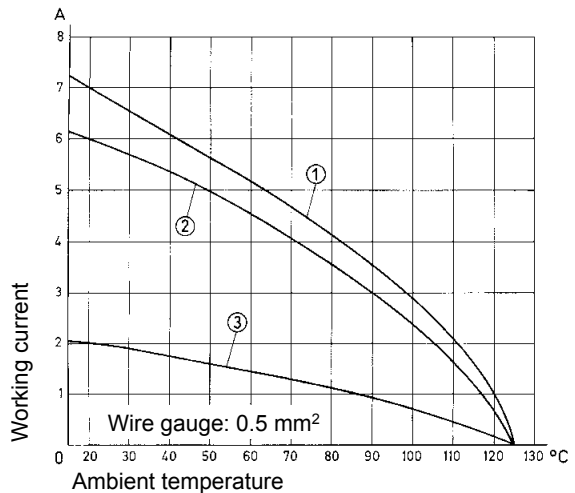

Example: 25 way connector

- ① Turned contacts
- ② Stamped contacts
- ③ Insulation displacement contacts

Contact arrangement View from termination side

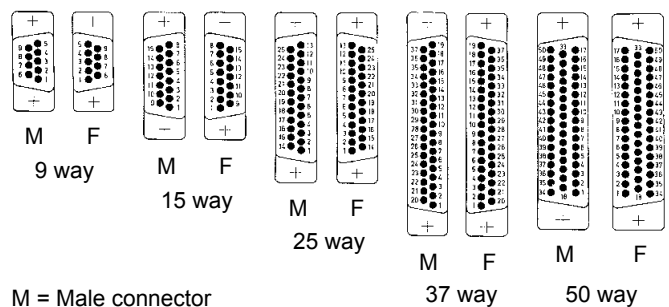

Mating conditions as per DIN 41652

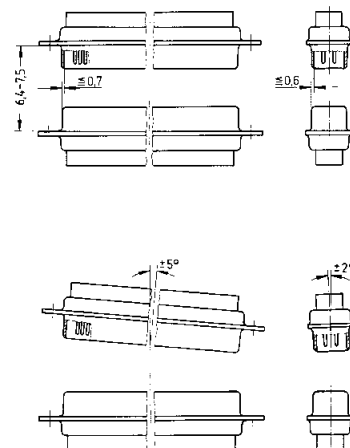

¹⁾ Performance level 3, 50 mating cycles, no gas test
Performance level 2 as per CECC 75301-802, 250 mating cycles, 4 days 4 mixed gas test – IEC 60512
Performance level 1 as per CECC 75301-802, 500 mating cycles, 10 days 4 mixed gas test – IEC 60512

Number of contacts

9-50



Crimp terminal

Identification	No. of contacts	Part number
Male connector Order contacts separately metal shell with dimples	9	09 67 009 5601
	15	09 67 015 5601
	25	09 67 025 5601
	37	09 67 037 5601
	50	09 67 050 5601
Female connector Order contacts separately metal shell	9	09 67 009 4701
	15	09 67 015 4701
	25	09 67 025 4701
	37	09 67 037 4701
	50	09 67 050 4701

Male connector

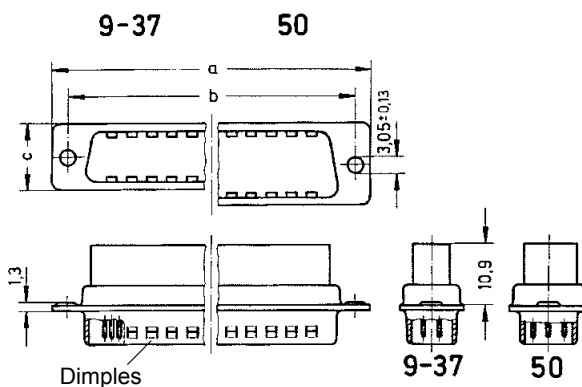

Female connector

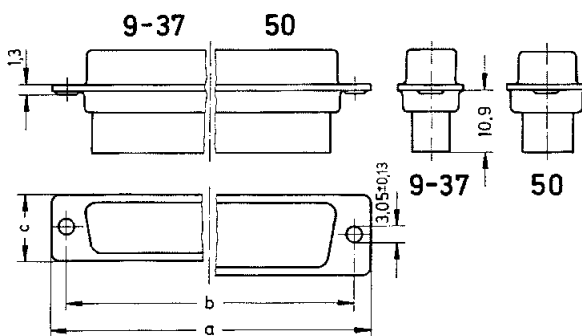

	a	b _{±0.1}	c
9	30.9	25.0	12.5
15	39.2	33.3	12.5
25	53.1	47.0	12.5
37	69.4	63.5	12.5
50	67.0	61.1	15.4

Panel cut out for front/rear mount

Values are taken from the CECC 75301-802

see page 05.24

Dimensions in mm



Turned crimp contacts

Identification	Wire gauge (mm ²)	Part number		
		Male contacts	Female contacts	High-end female contacts
		Performance level 1*	Performance level 1*	Performance level 1*
Individual contacts ¹⁾	AWG 22-18 0.33-0.82	09 67 000 3576	09 67 000 3476	09 67 000 3676
	AWG 24-20 0.25-0.52	09 67 000 8576	09 67 000 8476	09 67 000 8676
	AWG 26-22 0.13-0.33	09 67 000 5576	09 67 000 5476	09 67 000 5676
	AWG 28-24 0.09-0.25	09 67 000 7576	09 67 000 7476	09 67 000 7676

¹⁾ Minimum order 100 pieces or multiples of 100

Male contacts

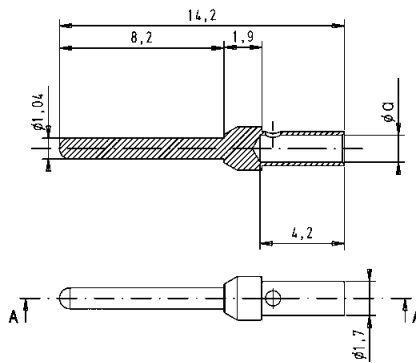

	a	groove
AWG 22-18	1.34	none
AWG 24-20	1.13	1
AWG 26-22	0.88	2
AWG 28-24	0.64	3

Female contacts

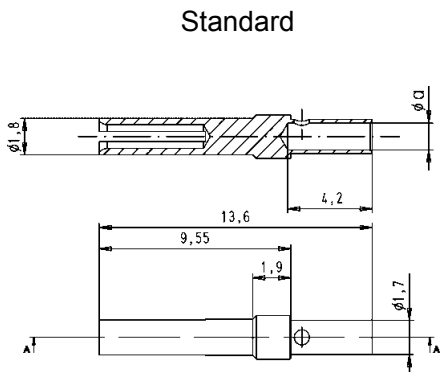

Standard

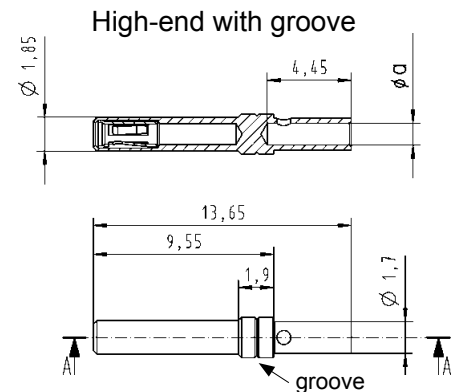

High-end with groove

D-Sub

* Performance level 1 as per CECC 75 301-802, 500 mating cycles, 10 days 4 mixed gas test – IEC 60512
Use crimp tool with the part no. 09 99 000 0501 and the locator with the part no. 09 99 000 0531. Details see chapter 20

Stamped crimp contacts



Identification	Wire gauge (mm ²)	Part number		
----------------	-------------------------------	-------------	--	--

D-Sub

Performance levels Explanations see page 05.04 Other performance levels on request		stamped male contacts		
		Performance level 3	Performance level 2	Performance level 1
Individual contacts	AWG 28-24 0.09-0.25 stranded	09 67 000 7177 ¹⁾	09 67 000 7178 ¹⁾	09 67 000 7176 ¹⁾
500 pieces/reel Unrolling left		09 67 000 7167	09 67 000 7168	09 67 000 7166
10 000 pieces/reel Unrolling left Unrolling left reversed Unrolling right reversed		09 67 000 7157 09 67 000 7147 09 67 000 7137	09 67 000 7158 09 67 000 7148 09 67 000 7138	09 67 000 7156 09 67 000 7146 09 67 000 7136
Individual contacts	AWG 24-20 0.25-0.56 stranded	09 67 000 8177 ¹⁾	09 67 000 8178 ¹⁾	09 67 000 8176 ¹⁾
500 pieces/reel Unrolling left		09 67 000 8167	09 67 000 8168	09 67 000 8166
10 000 pieces/reel Unrolling left Unrolling left reversed Unrolling right reversed		09 67 000 8157 09 67 000 8147 09 67 000 8137	09 67 000 8158 09 67 000 8148 09 67 000 8138	09 67 000 8156 09 67 000 8146 09 67 000 8136

Unrolling direction

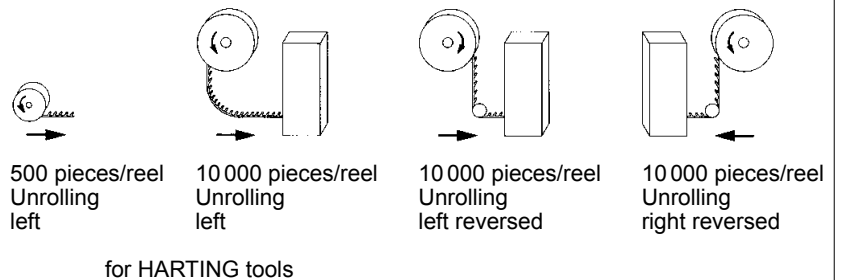

¹⁾ Minimum order 500 pieces or multiples of 500
Insertion and removal tool see chapter 20
Contact dimensions see page 05.29

Stamped crimp contacts



Identification

Drawing

Dimensions in mm

Male contacts

For bandoliered contacts only

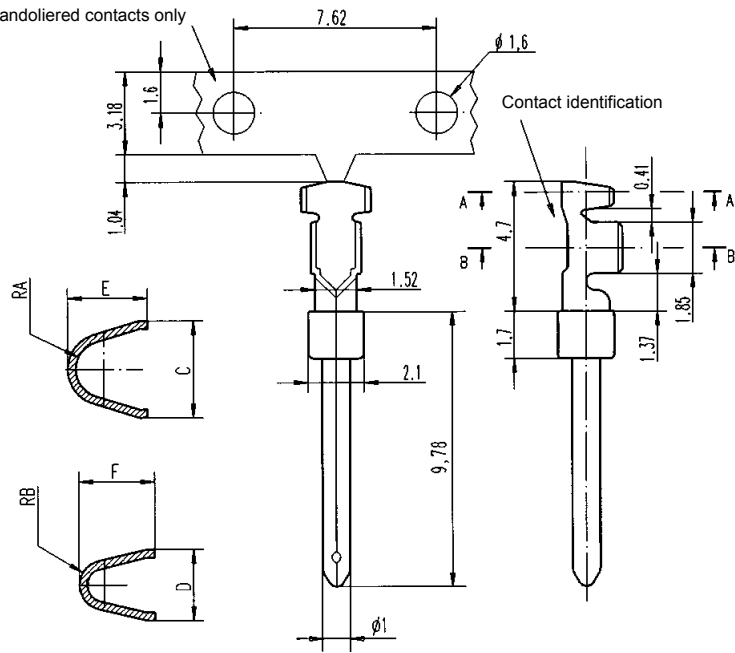

AWG	C	D	E	F	RA	RB	Contact identification
20-24	2.46	1.78	1.98	1.90	0.71	0.43	—
24-28	1.65	1.47	1.52	1.52	0.50	0.33	===

Stamped crimp contacts



Identification	Wire gauge (mm ²)	Part number		
		Performance level 3	Performance level 2	Performance level 1
Performance levels Explanations see page 05.04 Other performance levels on request		stamped female contacts		
Individual contacts	AWG 28-24	09 67 000 7277 ¹⁾	09 67 000 7278 ¹⁾	09 67 000 7276 ¹⁾
500 pieces/reel Unrolling left	0.09-0.25 stranded	09 67 000 7267	09 67 000 7268	09 67 000 7266
10 000 pieces/reel Unrolling left Unrolling left reversed Unrolling right reversed		09 67 000 7257 09 67 000 7247 09 67 000 7237	09 67 000 7258 09 67 000 7248 09 67 000 7238	09 67 000 7256 09 67 000 7246 09 67 000 7236
Individual contacts	AWG 24-20	09 67 000 8277 ¹⁾	09 67 000 8278 ¹⁾	09 67 000 8276 ¹⁾
500 pieces/reel Unrolling left	0.25-0.56 stranded	09 67 000 8267	09 67 000 8268	09 67 000 8266
10 000 pieces/reel Unrolling left Unrolling left reversed Unrolling right reversed		09 67 000 8257 09 67 000 8247 09 67 000 8237	09 67 000 8258 09 67 000 8248 09 67 000 8238	09 67 000 8256 09 67 000 8246 09 67 000 8236
Unrolling direction		<p>500 pieces/reel Unrolling left 10 000 pieces/reel Unrolling left 10 000 pieces/reel Unrolling left reversed 10 000 pieces/reel Unrolling right reversed</p> <p style="text-align: center;">for HARTING tools</p>		

D-Sub

¹⁾ Minimum order 500 pieces or multiples of 500
 Insertion and removal tool see chapter 20
 Contact dimensions see page 05.31

Stamped crimp contacts



Identification

Drawing

Dimensions in mm

Female contacts

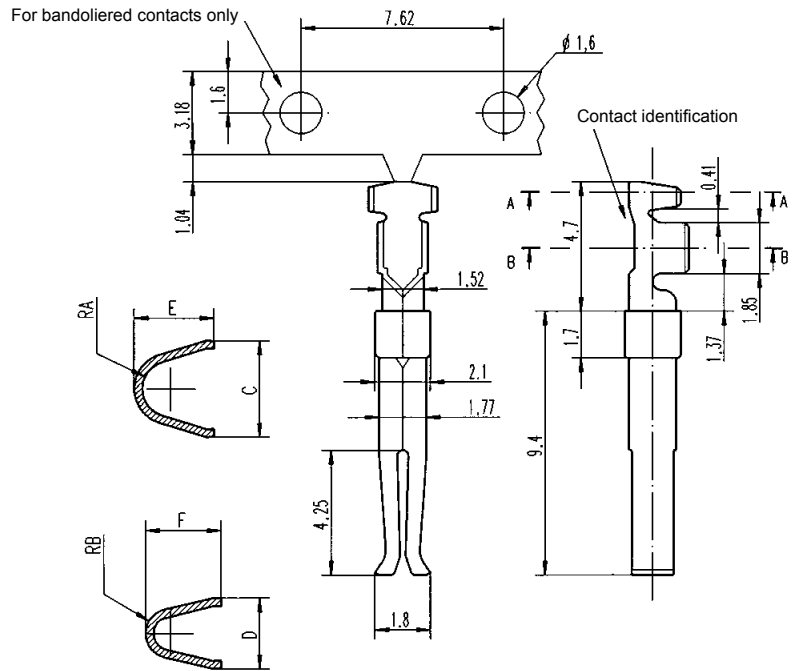

AWG	C	D	E	F	RA	RB	Contact identification
20-24	2.46	1.78	1.98	1.90	0.71	0.43	—
24-28	1.65	1.47	1.52	1.52	0.50	0.33	===

Number of contacts

9–37



Insulation displacement termination

Identification	No. of contacts	Part number	
		Performance level 3	Performance level 2
Performance levels Explanations see page 05.04 Other performance levels on request			
Male connector²⁾ pitch 1.27 mm metal shell with dimples	9 15 25 37	09 66 128 770 . 09 66 228 770 . 09 66 328 770 . 09 66 428 770 .	09 66 128 670 . 09 66 228 670 . 09 66 328 670 . 09 66 428 670 .
Female connector pitch 1.27 mm metal shell	9 15 25 37	09 66 118 750 . 09 66 218 750 . 09 66 318 750 . 09 66 418 750 .	09 66 118 650 . 09 66 218 650 . 09 66 318 650 . 09 66 418 650 .
Please insert digit for flange thread ø 3.1 mm hole ▶ 0 M3 ▶ 1 ¹⁾ 4-40 UNC ▶ 2			
Strain relief clamp plastic for male and female connector	9 15 25 37	09 66 108 0001 09 66 208 0001 09 66 308 0001 09 66 408 0001	09 66 108 0001 09 66 208 0001 09 66 308 0001 09 66 408 0001

1) Not normally kept in stock
 2) Not released for halogen free flat cables

Number of contacts

9-37

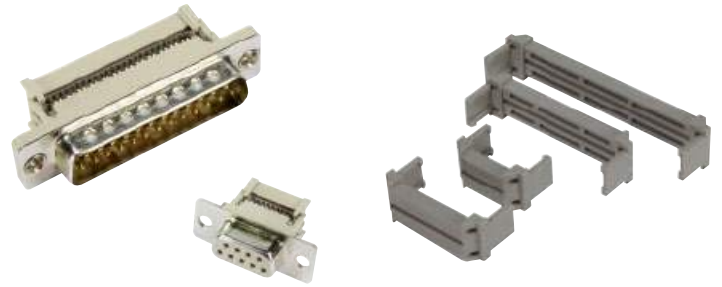

Insulation displacement termination

Identification

Drawing

Dimensions in mm

Male connector

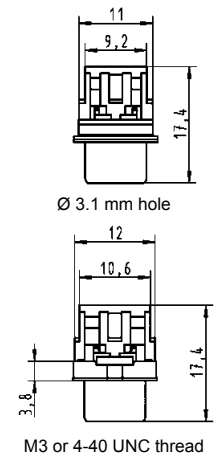
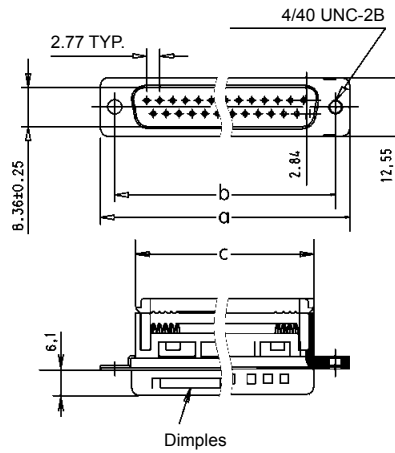

Female connector

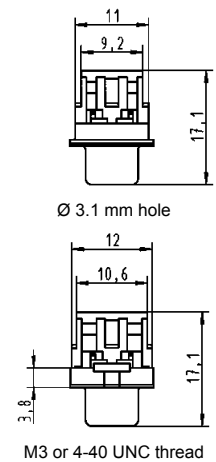
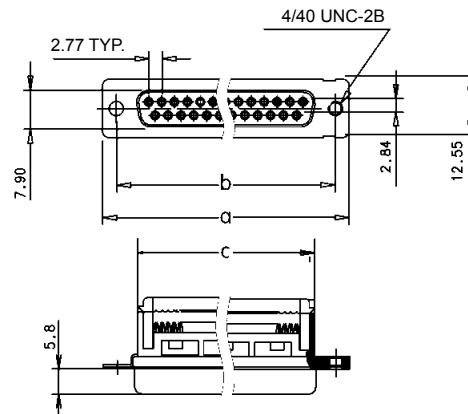

Male and female connectors

	a	b \pm 0.1	c
9	30.8	24.99	16.5
15	39.2	33.32	24.3
25	53.1	47.04	38.1
37	69.4	63.50	54.9

Specified conductors
stranded wires – AWG 28/7
– AWG 26/7

Strain relief clamps



Panel cut out
for front/rear mount

Values are taken from the
CECC 75301-802

see page 05.24

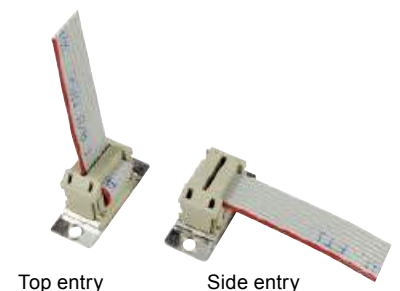

Top entry

Side entry

Number of contacts

9–50



Solder buckets

Identification	No. of contacts	Part number	
Performance levels Explanations see page 05.04 Other performance levels on request		Performance level 3	Performance level 2
Male connector metal shell with dimples		turned contacts	turned contacts
	9	09 67 009 5604	09 67 009 5615
	15	09 67 015 5604	09 67 015 5615
	25	09 67 025 5604	09 67 025 5615
	37	09 67 037 5604	09 67 037 5615
	50	09 67 050 5604	09 67 050 5615
		stamped contacts	stamped contacts
	9	09 67 209 5604	09 67 209 5615
	15	09 67 215 5604	09 67 215 5615
	25	09 67 225 5604	09 67 225 5615
37	09 67 237 5604	09 67 237 5615	
50	09 67 250 5604	09 67 250 5615	
Female connector metal shell		turned contacts	turned contacts
	9	09 67 009 4704	09 67 009 4715
	15	09 67 015 4704	09 67 015 4715
	25	09 67 025 4704	09 67 025 4715
	37	09 67 037 4704	09 67 037 4715
	50	09 67 050 4704	09 67 050 4715
		stamped contacts	stamped contacts
	9	09 67 209 4704	09 67 209 4715
	15	09 67 215 4704	09 67 215 4715
	25	09 67 225 4704	09 67 225 4715
37	09 67 237 4704	09 67 237 4715	
50	09 67 250 4704	09 67 250 4715	

Number of contacts

9-50



Solder buckets

Identification

Drawing

Dimensions in mm

Male connector

9-37

50

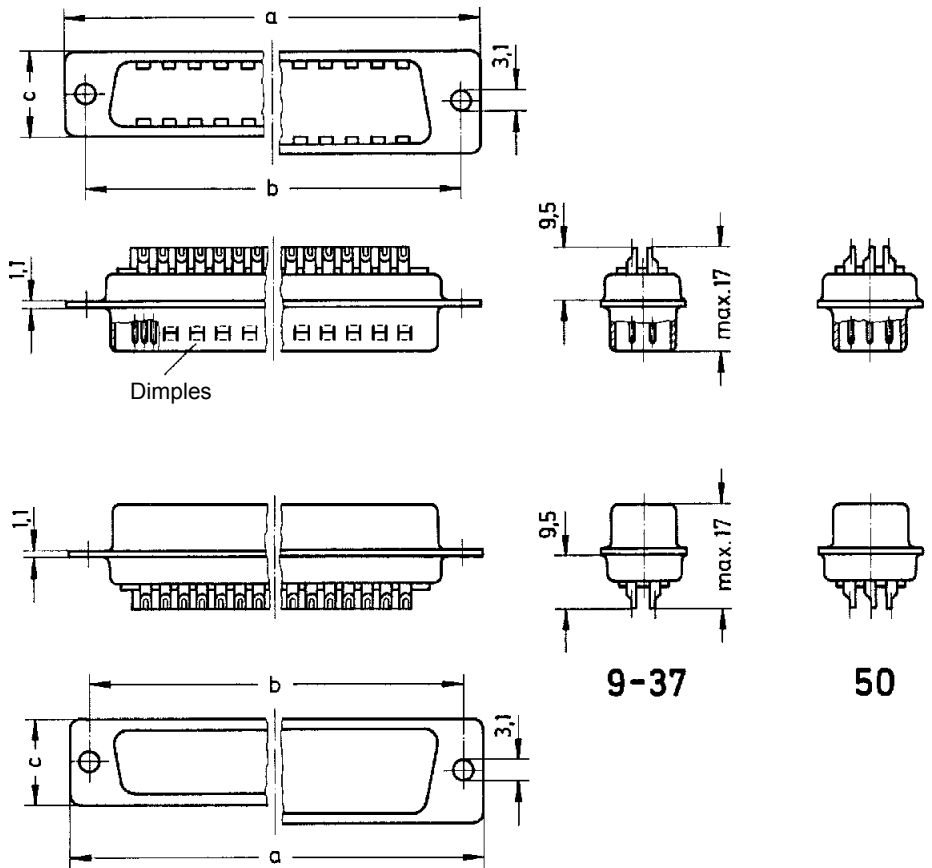

Female connector

	a	b ± 0.1	c
9	30.9	25.0	12.5
15	39.2	33.3	12.5
25	53.1	47.0	12.5
37	69.4	63.5	12.5
50	67.0	61.1	15.4

Panel cut out
for front/rear mount

Values are taken from the
CECC 75301-802

see page 05.24

Number of contacts

9-37



Gender changer

Identification	No. of contacts	Part number
Male / female gender changer	9	09 67 009 0605
	15	09 67 015 0605
	25	09 67 025 0605
	37	09 67 037 0605

Dimensions

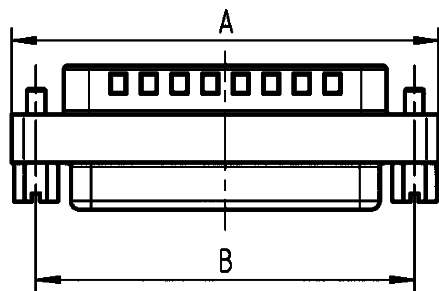
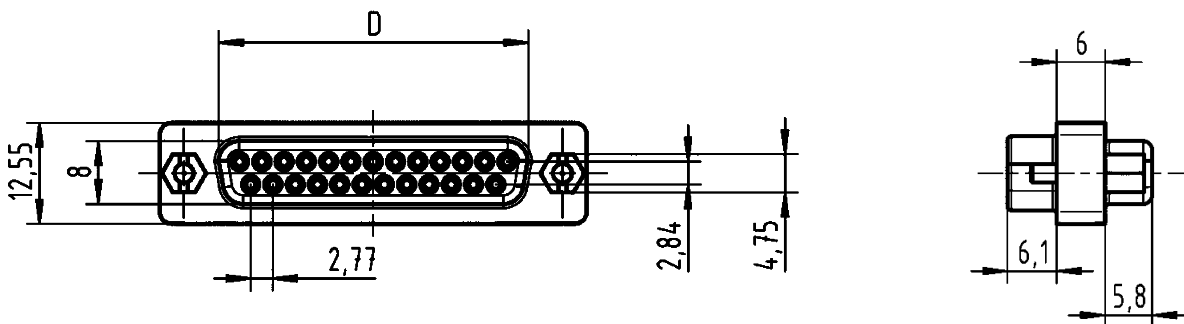

	A	B	C	D
9	30.8	25.0	16.92	16.35
15	39.2	33.3	25.25	24.7
25	53.05	47.04	38.96	38.4
37	69.4	63.5	55.42	54.8

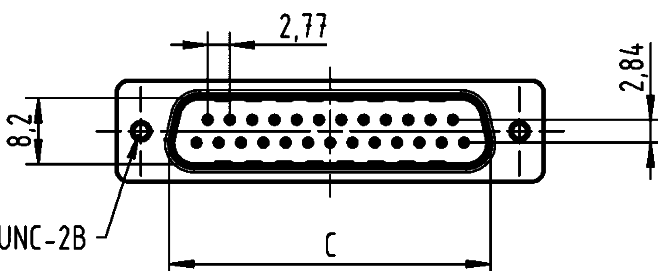

05 4-40UNC-2B

Number of contacts	15, 26, 44, 62, 78
Working current Stamped contacts	2 A max.
Test voltage $U_{r.m.s.}$	1 kV
Clearance and creepage	≥ 1.0 mm
Contact resistance	< 20 m Ω
Insulation resistance	< 25 m Ω (for right angled versions) $\geq 5 \times 10^9$ Ω
Temperature range	-40 °C ... + 85 °C The higher temperature limit includes the local ambient and heating effect of the contacts under load
Terminations	a) Solder pins \varnothing 0.65 mm for P.C.B. holes \varnothing 1.0 mm b) Crimp contacts AWG 26 - 24 0.14 - 0.22 mm ² max. insulation \varnothing 1.38 mm c) Solder cups AWG 24
Materials	
Mouldings and hoods	Thermoplastic resin, glass-fibre filled (PBTP), UL 94-V0
Contacts	Copper alloy
Contact surface	
Contact zone	selectively plated according to performance level ¹⁾
Metal shell	Nickel plated steel
Mating force	15 way ≤ 46 N 26 way ≤ 77 N 44 way ≤ 127 N 62 way ≤ 177 N 78 way ≤ 222 N



Number of contacts in the D-Sub standard/D-Sub high density range related to the shell size.

Shell size	D-Sub standard	D-Sub high density
1	9	15
2	15	26
3	25	44
4	37	62
5	50	78

¹⁾ Performance level 3, 50 mating cycles, no gas test
S4, plating = 0.76 μ m (30 μ inch) Au or PdNi equivalent

Number of contacts

15-78



High density crimp terminal

Identification	No. of contacts	Part number
Male connector Order contacts separately metal shell with dimples	15	09 56 100 5601
	26	09 56 200 5601
	44	09 56 300 5601
	62	09 56 400 5601
	78	09 56 500 5601
Female connector Order contacts separately metal shell	15	09 56 100 4701
	26	09 56 200 4701
	44	09 56 300 4701
	62	09 56 400 4701
	78	09 56 500 4701

Male connector

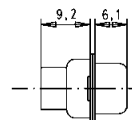
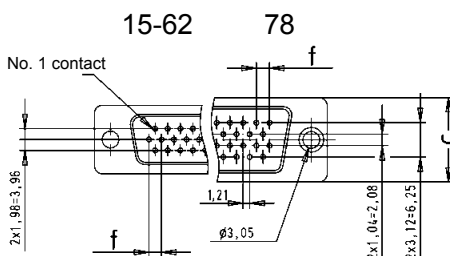

	a	b	c	f
15	30.9	25.0	12.5	2.29
26	39.2	33.3	12.5	2.29
44	53.1	47.0	12.5	2.29
62	69.4	63.5	12.5	2.41
78	67.0	61.1	15.4	2.41

Female connector

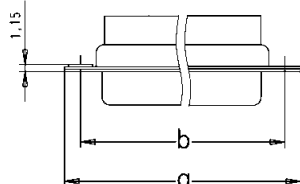
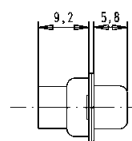
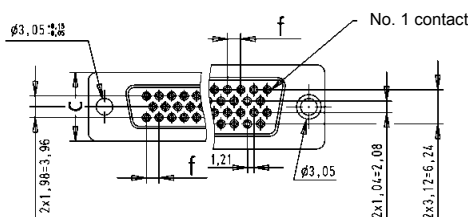

Panel cut out for front/rear mount

Values are taken from the CECC 75301-802

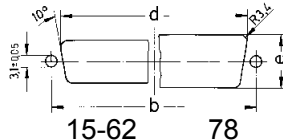

Front mount

	b \pm 0.13	d \pm 0.2	e \pm 0.2
15	25.0	22.2	12.3
26	33.3	30.5	12.3
44	47.0	44.3	12.3
62	63.5	60.7	12.3
78	61.1	58.3	15.1

Rear mount

	b \pm 0.13	d \pm 0.2	e \pm 0.2
15	25.0	20.5	11.4
26	33.3	28.8	11.4
44	47.0	42.5	11.4
62	63.5	59.1	11.4
78	61.1	56.3	14.1

Dimensions in mm

Crimp contacts for high density connectors



Identification	Wire gauge (mm ²)	Part number			
		stamped male contacts		stamped female contacts	
		Performance level 3	S4 ¹⁾	Performance level 3	S4 ¹⁾
Performance levels Explanations see page 05.04 Other performance levels on request					
500 pieces/box	AWG 26-24 0.14-0.22 stranded	09 56 000 8177	09 56 000 8175	09 56 000 8277	09 56 000 8275
500 pieces/reel Unrolling left		09 56 000 8167	09 56 000 8165	09 56 000 8267	09 56 000 8265
10 000 pieces/reel Unrolling left		09 56 000 8157	09 56 000 8155	09 56 000 8257	09 56 000 8255
Unrolling direction		<p>500 pieces/reel Unrolling left 10 000 pieces/reel Unrolling left</p> <p>for HARTING tools</p>			

D-Sub

¹⁾ S4 = 0.76 µm (30 µinch) Au or PdNi equivalent
 Contact dimensions see page 05.41

Crimp contacts for high density connectors



Identification

Drawing

Dimensions in mm

Male contacts

wire gauge AWG 26-24

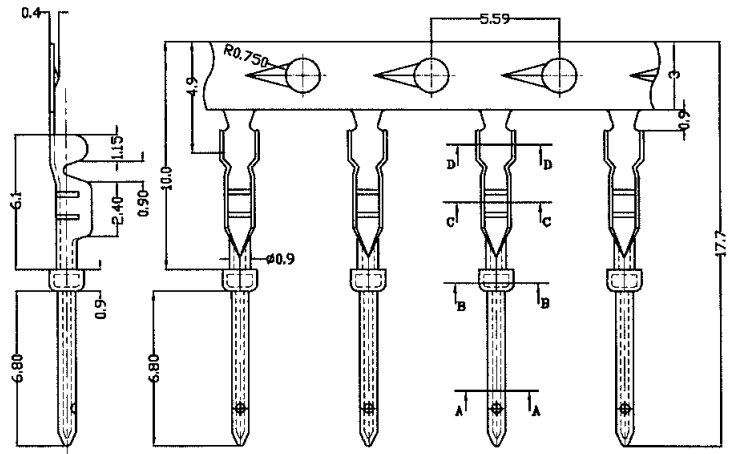
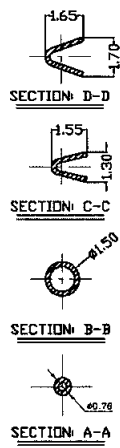

Female contacts

wire gauge AWG 26-24

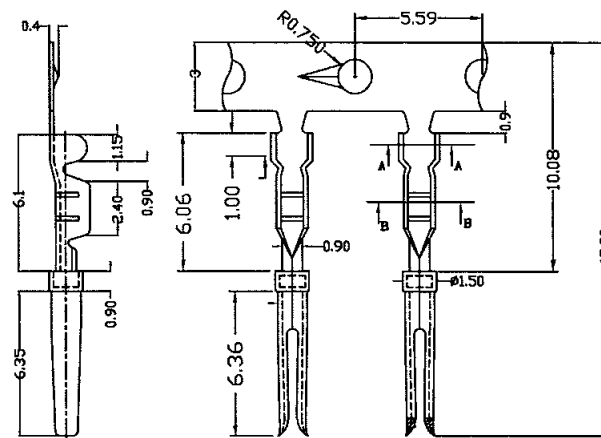
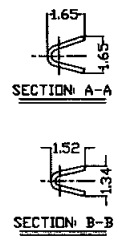

Number of contacts

15–78



High density with stamped solder cups, straight

Identification	No. of contacts	Part number	
Performance levels Explanations see page 05.04 Other performance levels on request		Performance level 3	S4¹⁾
Male connector metal shell with dimples	15 26 44 62 78	09 56 100 5604 09 56 200 5604 09 56 300 5604 09 56 400 5604 09 56 500 5604	09 56 100 5615 050 09 56 200 5615 050 09 56 300 5615 050 09 56 400 5615 050 09 56 500 5615 050
Female connector metal shell	15 26 44 62 78	09 56 100 4704 09 56 200 4704 09 56 300 4704 09 56 400 4704 09 56 500 4704	09 56 100 4715 050 09 56 200 4715 050 09 56 300 4715 050 09 56 400 4715 050 09 56 500 4715 050

D-Sub

¹⁾ S4 = 0.76 µm (30 µinch) Au or PdNi equivalent

Number of contacts

15-78



High density with stamped solder cups, straight

Identification

Drawing

Dimensions in mm

Male connector

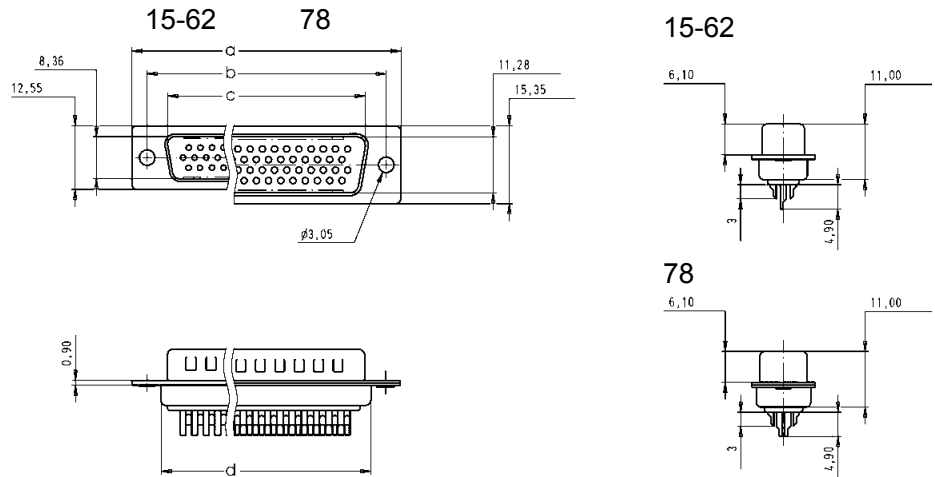

	a	b	c	d	e
15	30.81	25.00	16.92	19.20	16.33
26	39.20	33.30	25.25	27.70	24.70
44	53.05	47.00	38.96	41.10	38.40
62	69.40	63.50	55.42	57.30	54.80
78	67.00	61.00	52.81	55.10	52.20

Female connector

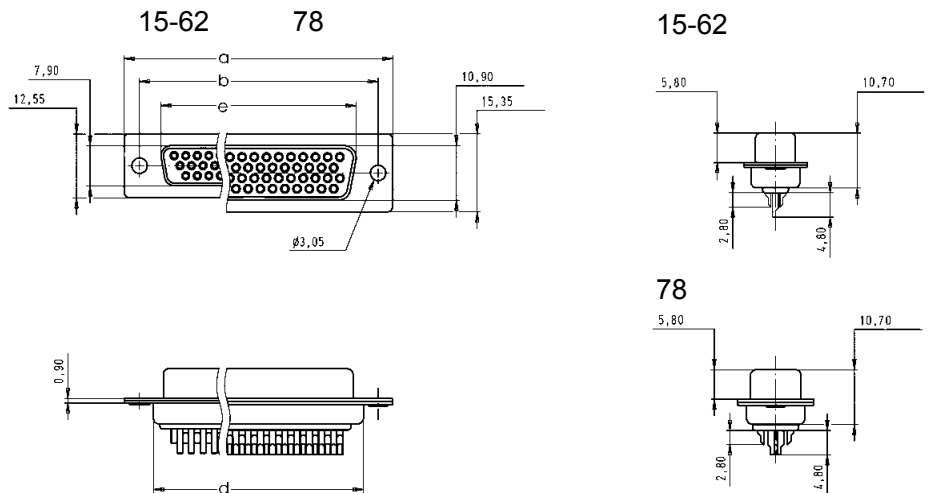

Number of contacts

15–78



High density with stamped solder pins, angled with grounding board locks

Identification	No. of contacts	Part number	
Performance levels Explanations see page 05.04 Other performance levels on request		Performance level 3	S4¹⁾
Male connector metal shell with dimples	15 26 44 62 78	09 56 162 781 . 09 56 262 781 . 09 56 362 781 . 09 56 462 781 . 09 56 562 781 .	09 56 162 581 . 09 56 262 581 . 09 56 362 581 . 09 56 462 581 . 09 56 562 581 .
Female connector metal shell	15 26 44 62 78	09 56 152 761 . 09 56 252 761 . 09 56 352 761 . 09 56 452 761 . 09 56 552 761 .	09 56 152 561 . 09 56 252 561 . 09 56 352 561 . 09 56 452 561 . 09 56 552 561 .
Please insert digit for flange thread or fitted female screw locks 4-40 UNC ▶ 2 fitted screw locks 4-40 UNC ▶ 3			

D-Sub

¹⁾ S4 = 0.76 µm (30 µinch) Au or PdNi equivalent

Number of contacts

15-78



High density with stamped solder pins, angled with grounding board locks

Identification

Drawing

Dimensions in mm

Male connector

15-62 78

15-62

78

No. 1 contact

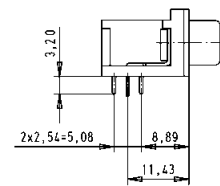
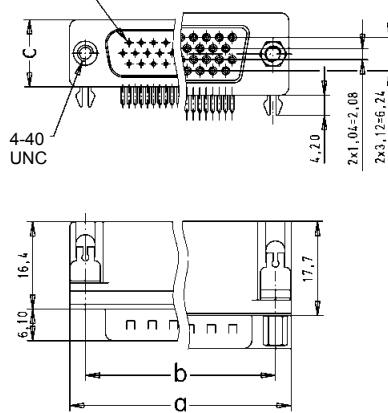

4-40 UNC

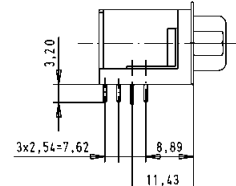

fitted screw locks
4-40 UNC

	a	b \pm 0.1	c
15	30.81	24.99	12.55
26	39.20	33.30	12.55
44	53.05	47.04	12.55
62	69.40	63.50	12.55
78	67.00	61.00	15.37

Female connector

15-62 78

15-62

78

4-40 UNC

No. 1 contact

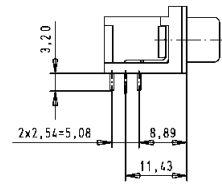
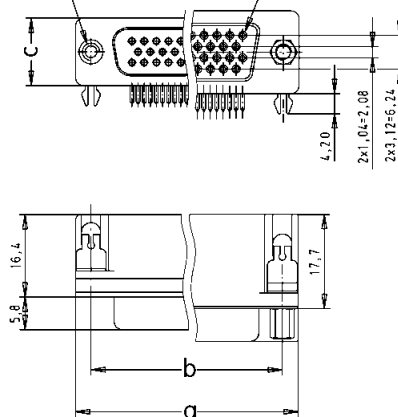

4-40 UNC

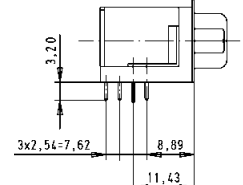

fitted screw locks
4-40 UNC

Number of contacts

15–78



High density with stamped solder pins, angled with grounding board locks

Identification

Drawing

Dimensions in mm

Board drillings

D-Sub

male 15

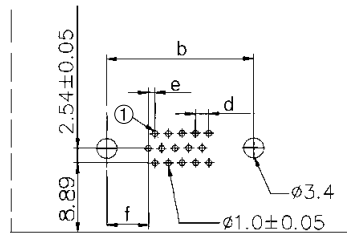

female 15

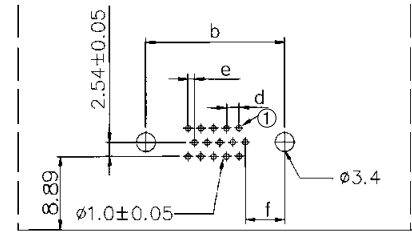

male 26-62

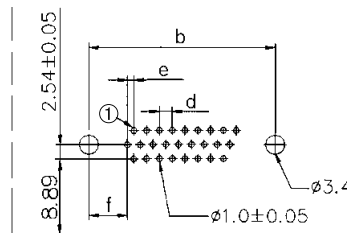

female 26-62

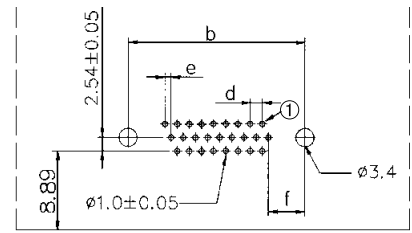

male 78

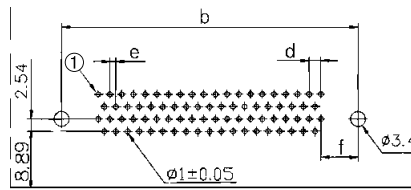

female 78

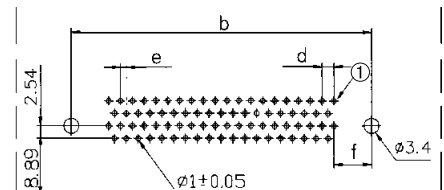

① = No. 1 contact

	$b_{\pm 0.1}$	d	e	f
15	24.99	2.29	1.145	7.04
26	33.30	2.29	1.145	6.88
44	47.04	2.29	1.145	6.88
62	63.50	2.41	1.205	7.00
78	61.00	2.41	1.205	7.65

Number of contacts

15–78



High density with stamped solder pins, straight

Identification	No. of contacts	Part number	
Performance levels Explanations see page 05.04 Other performance levels on request		Performance level 3	S4¹⁾
Male connector metal shell with dimples	15 26 44 62 78	09 56 161 7700 09 56 261 7700 09 56 361 7700 09 56 461 7700 09 56 561 7700	09 56 161 5700 09 56 261 5700 09 56 361 5700 09 56 461 5700 09 56 561 5700
Female connector metal shell	15 26 44 62 78	09 56 151 7500 09 56 251 7500 09 56 351 7500 09 56 451 7500 09 56 551 7500	09 56 151 5500 09 56 251 5500 09 56 351 5500 09 56 451 5500 09 56 551 5500

D-Sub

	15-62	78	15-62	78
Male connector				
Female connector				
Board drillings				

	a	b _{±0.1}	c	d
15	30.9	25.0	12.5	2.29
26	39.2	33.3	12.5	2.29
44	53.1	47.0	12.5	2.29
62	69.4	63.5	12.5	2.41
78	67.0	61.1	15.4	2.41

¹⁾ S4 = 0.76 µm (30 µinch) Au or PdNi equivalent

Number of contacts

15–78

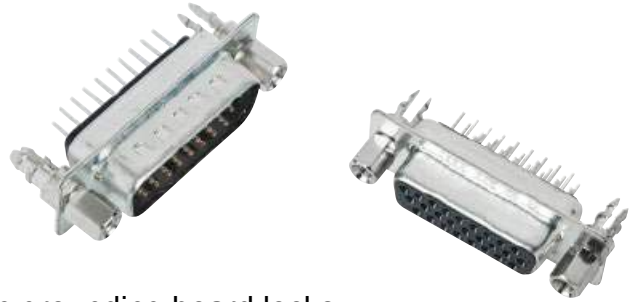

High density with stamped solder pins, straight with grounding board locks

Identification	No. of contacts	Part number	
Performance levels Explanations see page 05.04 Other performance levels on request		Performance level 3	S4 ¹⁾
Male connector metal shell with dimples	15 26 44 62 78	09 56 161 771 . 09 56 261 771 . 09 56 361 771 . 09 56 461 771 . 09 56 561 771 .	09 56 161 571 . 09 56 261 571 . 09 56 361 571 . 09 56 461 571 . 09 56 561 571 .
Female connector metal shell	15 26 44 62 78	09 56 151 751 . 09 56 251 751 . 09 56 351 751 . 09 56 451 751 . 09 56 551 751 .	09 56 151 551 . 09 56 251 551 . 09 56 351 551 . 09 56 451 551 . 09 56 551 551 .
Please insert digit for flange thread or fitted female screw locks 4-40 UNC ▶ 2 fitted screw locks 4-40 UNC ▶ 3			

D-Sub

¹⁾ S4 = 0.76 µm (30 µinch) Au or PdNi equivalent

Number of contacts

15-78



High density with stamped solder pins, straight with grounding board locks

Identification

Drawing

Dimensions in mm

Male connector

15-62 78

15-62

78

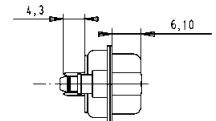
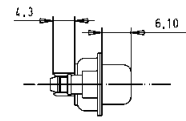
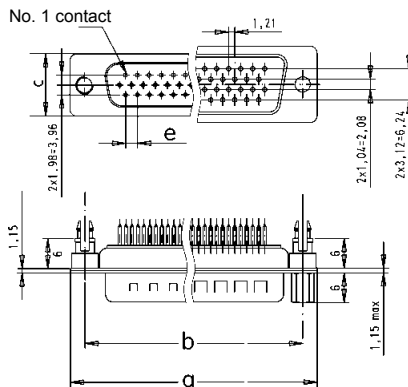

4-40 UNC

fitted screw locks
4-40 UNC

	a	b ± 0.1	c	e
15	30.9	25.0	12.5	2.29
26	39.2	33.3	12.5	2.29
44	53.1	47.0	12.5	2.29
62	69.4	63.5	12.5	2.41
78	67.0	61.1	15.4	2.41

Female connector

15-62 78

15-62

78

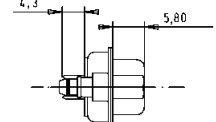
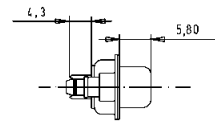
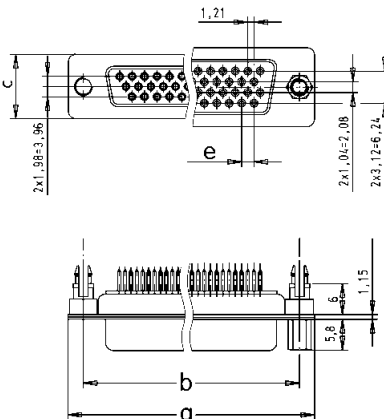

4-40 UNC

fitted screw locks
4-40 UNC

Board drillings

male 15-62

female 15-62

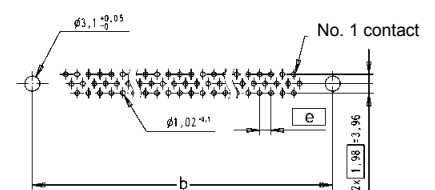
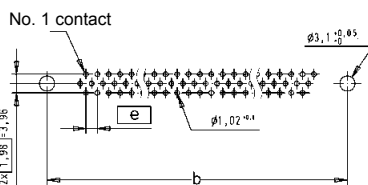

male 78

female 78

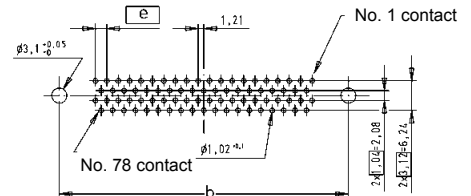
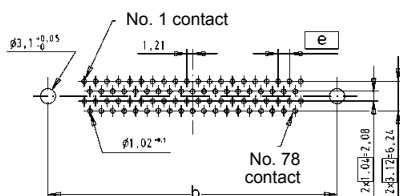

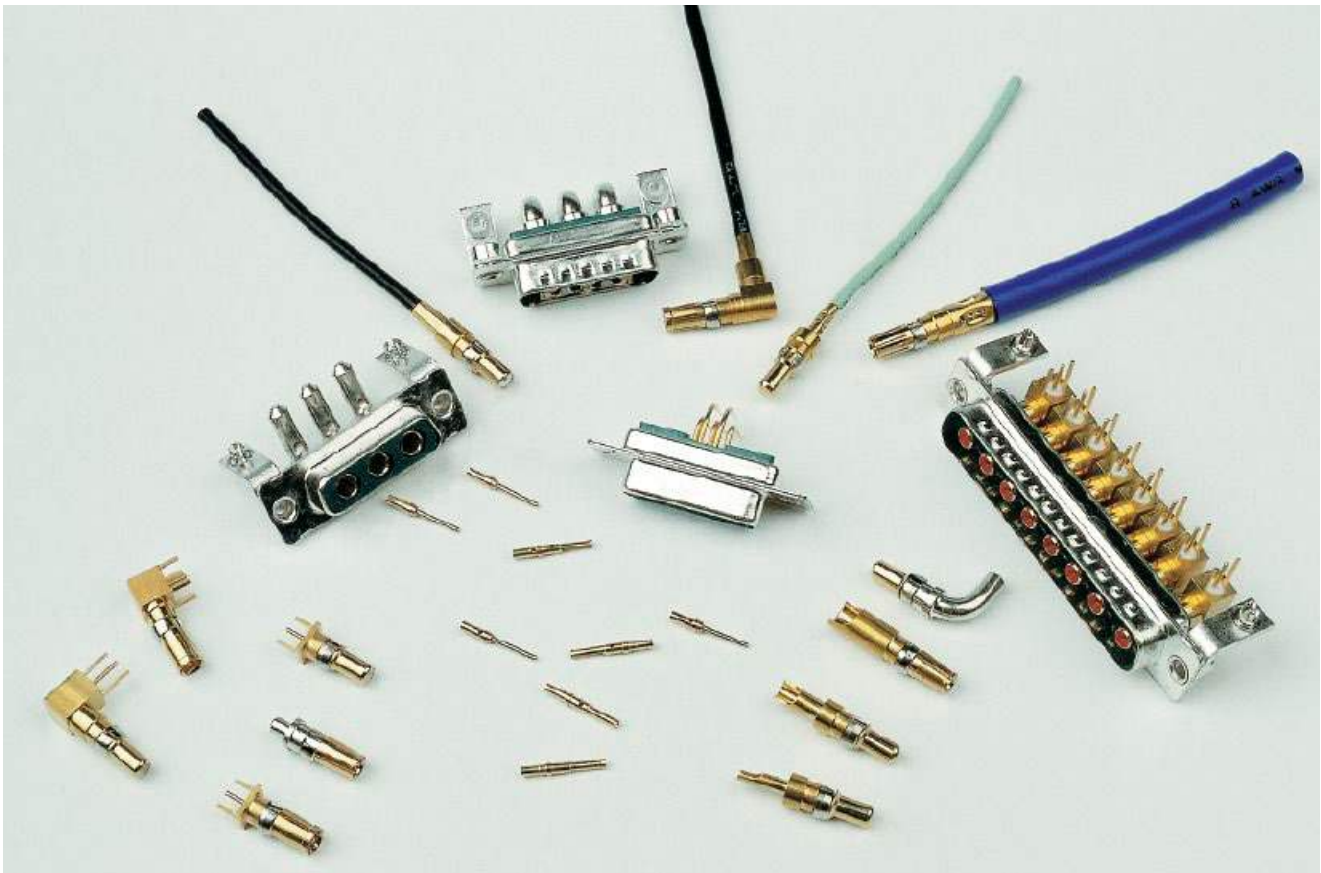

HARTINGs' mixed D-Sub range brings the advantage of an industry standard I/O inter-connect product with the possibility to customise for any application.

The range is designed around **the standard D-Sub shell sizes** with **the possibility to have a blend of contacts** such as signals with coaxial, power, high voltage or pneumatic contacts. Due to its construction, the product is **fully shielded** and helps reducing the EMI/RFI leakage.

All contacts are machined with two different platings.

When hot plug-in is required, **first mate last break** contacts can also be supplied.

For connectors to be fitted on a board with SMT components, they can be supplied in an **SMC (PiHIR) version** which is assembled in the reflow solder process, thus reducing assembly cost.

In addition, a complete range of accessories such as clinch nut, spacers, board locks, female screw lock, etc. are available. For **blind mating feature**, a specific high performance solution has been developed based on the combination of a floating plate and guiding pins providing up to 2.2 mm realignment capability. With all these accessories, the requirements of most applications are achievable and it makes this product range very attractive thanks to its versatility, reliability and cost effectiveness.



This blind mating concept is also achievable on the standard D as shown on the photo.

Contact arrangements

The table shows the standard range supported by HARTING. Two versions are special since they allow to mix in the same shell male and female contacts: 2W2C and 3W3C. The purpose of these versions is to have a 100 % mating proof feature (the insulator shape prevents a 180° reversed mating).

The structure of the connectors' identification is so that the left side digits give the total number of contacts and the right side digits the number of special contacts which can be either power, coaxial or high voltage style.

Example: 13W3 stands for 13 contacts in total with 10 signal contacts and 3 special contacts.

	Shell size	
2W2	1	
2W2C	1	
5W1	1	
3W3	2	
3W3C	2	
7W2	2	
11W1	2	
5W5	3	
9W4	3	
13W3	3	
17W2	3	
21W1	3	

	Shell size	
7W7	4	
8W8	4	
13W6	4	
21WA4	4	
25W3	4	
27W2	4	
24W7	5	
36W4	5	
43W2	5	

Note:
for any other layout please consult your HARTING representative.

Connectors for pcb applications – general information

The range of pcb connectors available at HARTING is summarised in the table under. For each of the basic connector versions, the available contact styles are documented with termination process, pitch, plating, rating for power contacts and impedance for coaxial contact etc..., as well as the accessory configuration.

Pcb connectors are delivered fully loaded thus providing a very good positioning of the contacts in their cavities for an easy and safe insertion of the pins in the pcb holes particularly crucial in the right angled versions.



Due to the numerous possibilities offered with the pcb connectors, suggested method is to contact your local HARTING representative to determine the part number to order; see customer request form on pages 05.88 and 05.89.

	Straight		Right angled	
Insulator body	<ul style="list-style-type: none"> • Standard • SMC: Solder Reflow Compatible 		<ul style="list-style-type: none"> • Standard • SMC: Solder Reflow Compatible 	
Signal contacts	Solder termination <ul style="list-style-type: none"> • Pitch: 2.84 mm • Plating: 0.76 µm Au over Ni • Pcb thickness from 1.6 to 3.2 mm 		Solder termination <ul style="list-style-type: none"> • Pitch: 2.54 mm • Plating: 0.76 µm Au over Ni • Pcb thickness from 1.6 to 3.2 mm 	
Power contacts	Solder termination <ul style="list-style-type: none"> • Rating: 20, 30, 40 A • Plating: 0.76 µm Au over Ni Press-in termination <ul style="list-style-type: none"> • Rating: 30 A • Plating: 0.76 µm Au over Ni 		Solder termination <ul style="list-style-type: none"> • Rating: 20, 30, 40 A • Plating: 0.76 µm Au over Ni 	
Coaxial contacts	Solder termination <ul style="list-style-type: none"> • 50 or 75 Ω • Plating: 1.3 µm Au over Ni inner conductor 0.76 µm Au over Ni outer ring 		Solder termination <ul style="list-style-type: none"> • 50 or 75 Ω • Plating: 1.3 µm Au over Ni inner conductor 0.76 µm Au over Ni outer ring 	
Accessories	Through hole		Metal bracket with board lock and through hole	
	Nut: M3 or UNC 4-40		Metal bracket with board lock and clinch nut M3 or UNC 4-40	
	Spacer: M3 or UNC 4-40		Metal bracket with board lock and female screw lock UNC 4-40	
	Spacer (M3 or UNC 4-40) with board lock			
	Spacer + board lock + female screw lock M3 or UNC 4-40			

D-Sub

Connectors for cable applications – general information

Two termination processes are available: crimp or solder

<p>Shell</p>																						
<p>Signal contacts</p>	<p>Crimp termination</p> <ul style="list-style-type: none"> For wire gauge: AWG 20-24 or 26-28 Plating: 0.76 µm or 0.2 µm Au over Ni 	<p>Pre-mounted solder cup contacts</p> <ul style="list-style-type: none"> Plating: 0.76 µm or 0.1 µm Au over Ni 																				
<p>Power contacts</p>	<p>Crimp</p> <ul style="list-style-type: none"> Rating: 10, 20, 30, 40 A Plating: <table border="0"> <tr> <td>Mating side</td> <td>0.76 µm or 0.2 µm Au</td> </tr> <tr> <td>Terminating side</td> <td>0.2 µm Au</td> </tr> </table> <p>Solder cup</p> <ul style="list-style-type: none"> Rating: 10, 20, 30, 40 A Plating: <table border="0"> <tr> <td>Mating side</td> <td>0.76 µm or 0.2 µm Au</td> </tr> <tr> <td>Terminating side</td> <td>0.2 µm Au or 5 µm Sn</td> </tr> </table> 	Mating side	0.76 µm or 0.2 µm Au	Terminating side	0.2 µm Au	Mating side	0.76 µm or 0.2 µm Au	Terminating side	0.2 µm Au or 5 µm Sn	<p>Crimp</p> <ul style="list-style-type: none"> Rating: 10, 20, 30, 40 A Plating: <table border="0"> <tr> <td>Mating side</td> <td>0.76 µm or 0.2 µm Au</td> </tr> <tr> <td>Terminating side</td> <td>0.2 µm Au</td> </tr> </table> <p>Solder cup</p> <ul style="list-style-type: none"> Rating: 10, 20, 30, 40 A Plating: <table border="0"> <tr> <td>Mating side</td> <td>0.76 µm or 0.2 µm Au</td> </tr> <tr> <td>Terminating side</td> <td>0.2 µm Au or 5 µm Sn</td> </tr> </table> 	Mating side	0.76 µm or 0.2 µm Au	Terminating side	0.2 µm Au	Mating side	0.76 µm or 0.2 µm Au	Terminating side	0.2 µm Au or 5 µm Sn				
Mating side	0.76 µm or 0.2 µm Au																					
Terminating side	0.2 µm Au																					
Mating side	0.76 µm or 0.2 µm Au																					
Terminating side	0.2 µm Au or 5 µm Sn																					
Mating side	0.76 µm or 0.2 µm Au																					
Terminating side	0.2 µm Au																					
Mating side	0.76 µm or 0.2 µm Au																					
Terminating side	0.2 µm Au or 5 µm Sn																					
<p>Coaxial contacts¹⁾</p>	<p>Solder/crimp termination resp. Crimp/crimp termination</p> <ul style="list-style-type: none"> 50 or 75 Ω Plating: <table border="0"> <tr> <td>Mating side</td> <td>1.3 µm or 0.2 µm Au inner conductor</td> </tr> <tr> <td></td> <td>0.76 µm or 0.2 µm Au outer ring</td> </tr> <tr> <td>Terminating side</td> <td>1.3 µm or 0.2 µm Au inner conductor</td> </tr> <tr> <td></td> <td>0.2 µm Au or 5 µm Sn outer ring</td> </tr> <tr> <td>Ferrule</td> <td>0.2 µm Au or 5 µm Sn</td> </tr> </table> Cables: RG 178, 179 ... 	Mating side	1.3 µm or 0.2 µm Au inner conductor		0.76 µm or 0.2 µm Au outer ring	Terminating side	1.3 µm or 0.2 µm Au inner conductor		0.2 µm Au or 5 µm Sn outer ring	Ferrule	0.2 µm Au or 5 µm Sn	<p>Solder/crimp termination resp. Crimp/crimp termination</p> <ul style="list-style-type: none"> 50 or 75 Ω Plating: <table border="0"> <tr> <td>Mating side</td> <td>1.3 µm or 0.2 µm Au inner conductor</td> </tr> <tr> <td></td> <td>0.76 µm or 0.2 µm Au outer ring</td> </tr> <tr> <td>Terminating side</td> <td>1.3 µm or 0.2 µm Au inner conductor</td> </tr> <tr> <td></td> <td>0.2 µm Au or 5 µm Sn outer ring</td> </tr> <tr> <td>Ferrule</td> <td>0.2 µm Au or 5 µm Sn</td> </tr> </table> Cables: RG 178, 179 ... 	Mating side	1.3 µm or 0.2 µm Au inner conductor		0.76 µm or 0.2 µm Au outer ring	Terminating side	1.3 µm or 0.2 µm Au inner conductor		0.2 µm Au or 5 µm Sn outer ring	Ferrule	0.2 µm Au or 5 µm Sn
Mating side	1.3 µm or 0.2 µm Au inner conductor																					
	0.76 µm or 0.2 µm Au outer ring																					
Terminating side	1.3 µm or 0.2 µm Au inner conductor																					
	0.2 µm Au or 5 µm Sn outer ring																					
Ferrule	0.2 µm Au or 5 µm Sn																					
Mating side	1.3 µm or 0.2 µm Au inner conductor																					
	0.76 µm or 0.2 µm Au outer ring																					
Terminating side	1.3 µm or 0.2 µm Au inner conductor																					
	0.2 µm Au or 5 µm Sn outer ring																					
Ferrule	0.2 µm Au or 5 µm Sn																					
<p>High voltage contacts</p>	<p>Solder termination</p> <ul style="list-style-type: none"> Plating: 1.3 µm Au over Ni terminating and mating side 	<p>Solder termination</p> <ul style="list-style-type: none"> Plating: 1.3 µm Au over Ni terminating and mating side 																				

¹⁾ Coaxial contacts are provided in two versions:

- Inner conductor soldered and outer part crimped (solder/crimp termination)
- Both inner and outer part crimped (crimp/crimp termination); this version is recommended for medium or large size volume since crimping is faster than soldering.

Number of contacts 2, 3, 5, 7, 8, 9, 11, 13, 17, 21, 24, 25, 27, 36, 43

Approvals DIN 41652, part 1

Working current 5 A for signal contacts

Temperature range -55 °C ... +125 °C
 The higher temperature limit includes the ambient and heating effect of the contacts under load

Materials
 Mouldings Thermoplastic resin, glass-fibre filled (Polyester)
 UL 94-V0
 color: green for standard
 black for crimp
 Metal shell Tin plated steel



Number of contacts

7-27



Mixed shells with pre-mounted signal solder cup contacts

Identification	No. of contacts ¹⁾	Part number			
		male connectors		female connectors	
		Performance level 3	S4 ²⁾	Performance level 3	S4 ²⁾
	7W2	09 69 211 7072	09 69 211 5072	09 69 201 7072	09 69 201 5072
	17W2	09 69 311 7172	09 69 311 5172	09 69 301 7172	09 69 301 5172
	21WA4	09 69 411 7214	09 69 411 5214	09 69 401 7214	09 69 401 5214
	27W2	09 69 411 7272	09 69 411 5272	09 69 401 7272	09 69 401 5272

Male connectors

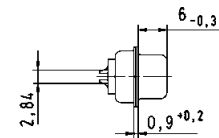
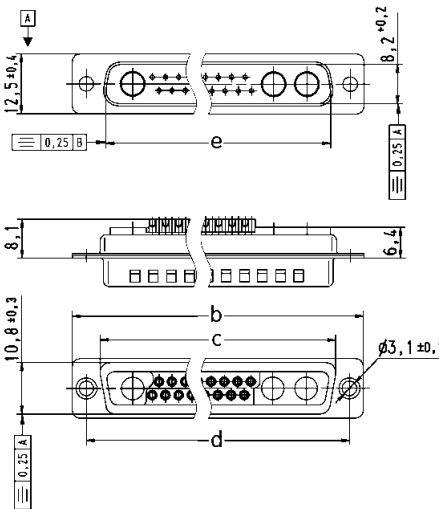

Solder cup termination for AWG 20 (0.5 mm²)

	a	b	c	d	e
7W2	24.6	39.1	27.5	33.30	25.2
17W2	38.3	53.0	41.3	47.04	38.9
21WA4	54.8	69.3	57.7	63.50	55.3
27W2	54.9	69.3	57.7	63.50	55.3

Female connectors

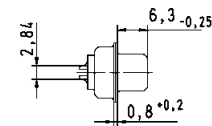
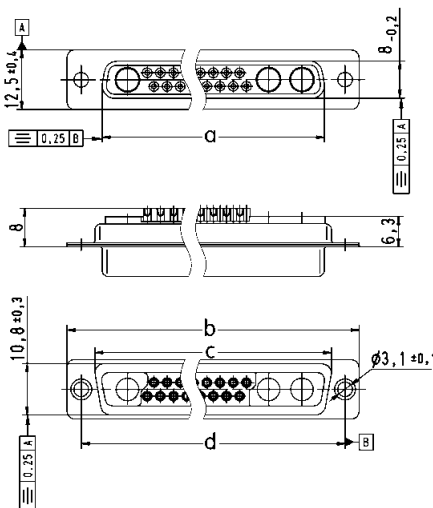

Solder cup termination for AWG 20 (0.5 mm²)

Dimensions in mm

¹⁾ Explanations see page 05.51

²⁾ S4 = 0.76 µm Au or PdNi equivalent

Board drillings see pages 05.78 ff

Order special contacts separately. See pages 05.69 ff

D-Sub

Number of contacts

9-25



Mixed shells with pre-mounted signal solder cup contacts

Identification	No. of contacts ¹⁾	Part number			
		male connectors		female connectors	
		Performance level 3	S4 ²⁾	Performance level 3	S4 ²⁾
	9W4	09 69 311 7094	09 69 311 5094	09 69 301 7094	09 69 301 5094
	13W3	09 69 311 7133	09 69 311 5133	09 69 301 7133	09 69 301 5133
	25W3	09 69 411 7253	09 69 411 5253	09 69 401 7253	09 69 401 5253

Male connectors

9W4

Solder cup termination for AWG 20 (0.5 mm²)

13W3, 25W3

Solder cup termination for AWG 20 (0.5 mm²)

	b	c	d	e
13W3	53.0	41.3	47.04	38.90
25W3	69.3	57.7	63.50	49.84

Dimensions in mm

¹⁾ Explanations see page 05.51
²⁾ S4 = 0.76 µm Au or PdNi equivalent
 Board drillings see pages 05.78 ff

Drawings for female connectors see page 05.57
 Order special contacts separately. See pages 05.69 ff

Number of contacts

9-25



Mixed shells with pre-mounted signal solder cup contacts

Identification

Drawing

Dimensions in mm

Female connectors

9W4

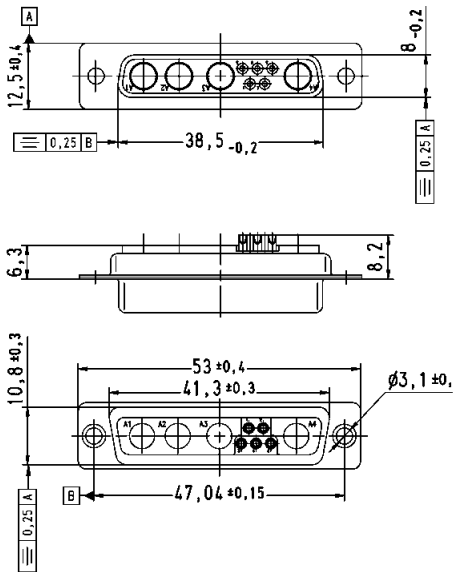

Solder cup termination for AWG 20 (0.5 mm²)

13W3, 25W3

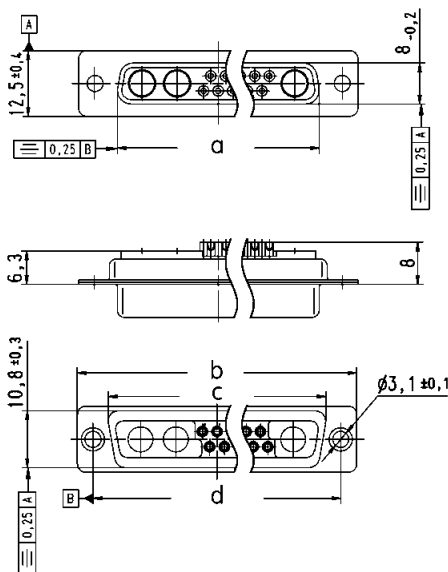

Solder cup termination for AWG 20 (0.5 mm²)

	a	b	c	d
13W3	38.3	53.0	41.3	47.04
25W3	54.9	69.3	57.7	63.50

Number of contacts

5-21



Mixed shells with pre-mounted signal solder cup contacts

Identification	No. of contacts ¹⁾	Part number			
		male connectors		female connectors	
		Performance level 3	S4 ²⁾	Performance level 3	S4 ²⁾
	5W1	09 69 111 7051	09 69 111 5051	09 69 101 7051	09 69 101 5051
	11W1	09 69 211 7111	09 69 211 5111	09 69 201 7111	09 69 201 5111
	21W1	09 69 311 7211	09 69 311 5211	09 69 301 7211	09 69 301 5211

Male connectors

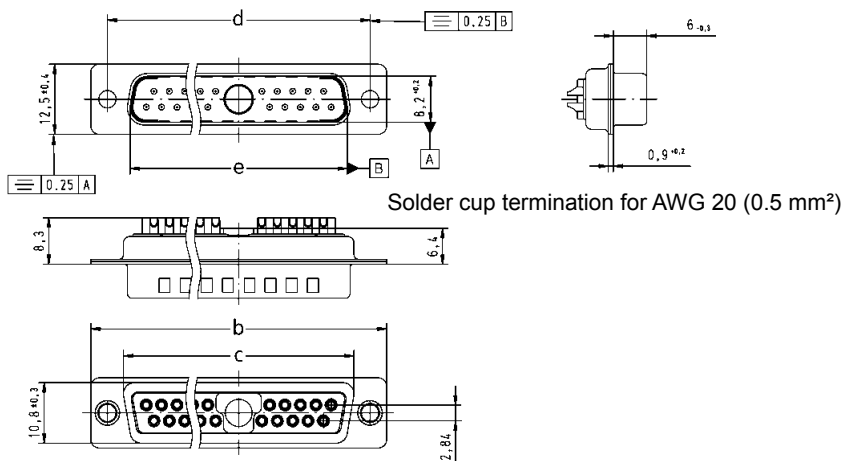

Female connectors

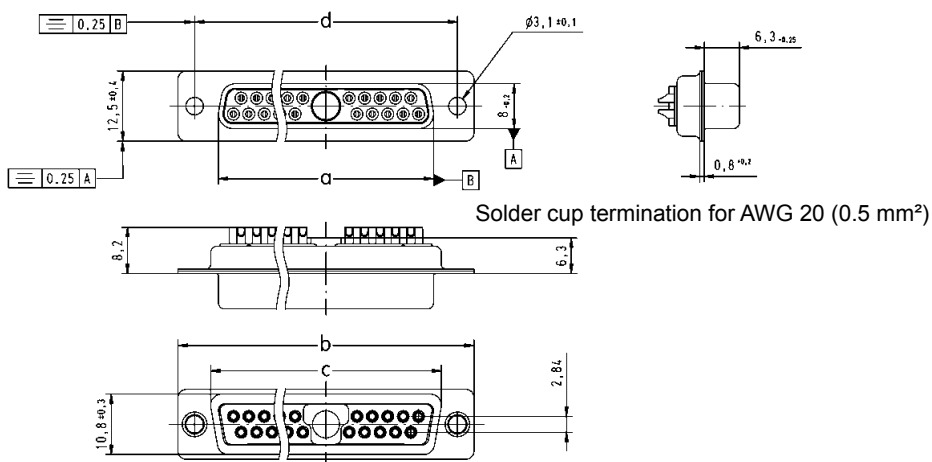

	a	b	c	d	e
5W1	16.4	30.8	19.3	25.00	16.9
11W1	24.7	39.1	27.5	33.30	25.2
21W1	38.5	53.0	41.3	47.04	38.9

Dimensions in mm

¹⁾ Explanations see page 05.51
²⁾ S4 = 0.76 µm Au or PdNi equivalent
 Board drillings see pages 05.78 ff

Order special contacts separately. See pages 05.69 ff

Number of contacts

13



Mixed shells with pre-mounted signal solder cup contacts

Identification	No. of contacts ¹⁾	Part number			
		male connectors		female connectors	
		Performance level 3	S4 ²⁾	Performance level 3	S4 ²⁾
	13W6	09 69 411 7136	09 69 411 5136	09 69 401 7136	09 69 401 5136

Male connectors

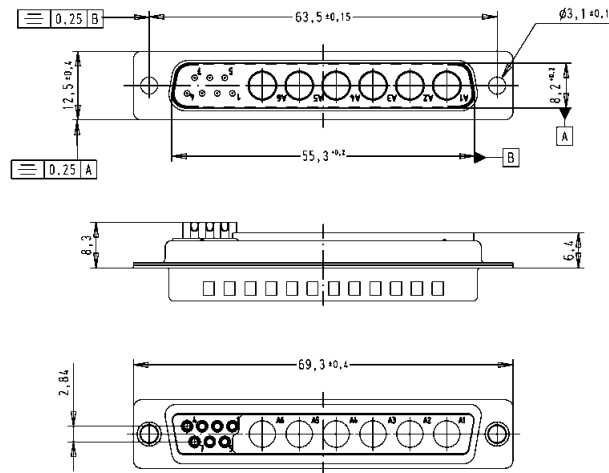

Solder cup termination for AWG 20 (0.5 mm²)

Female connectors

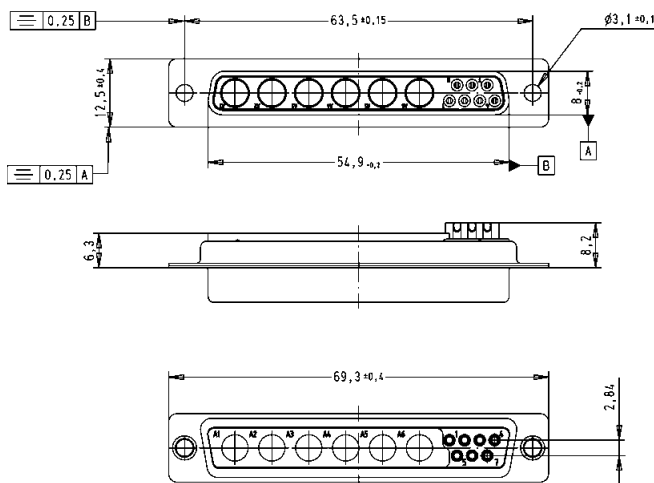

Solder cup termination for AWG 20 (0.5 mm²)

Dimensions in mm

¹⁾ Explanations see page 05.51
²⁾ S4 = 0.76 µm Au or PdNi equivalent
 Board drillings see pages 05.78 ff

Order special contacts separately. See pages 05.69 ff

D-Sub

Number of contacts

24



Mixed shells with pre-mounted signal solder cup contacts

Identification	No. of contacts ¹⁾	Part number			
		male connectors		female connectors	
		Performance level 3	S4 ²⁾	Performance level 3	S4 ²⁾
	24W7	09 69 511 7247	09 69 511 5247	09 69 501 7247	09 69 501 5247

Male connectors

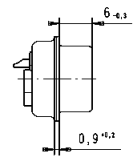
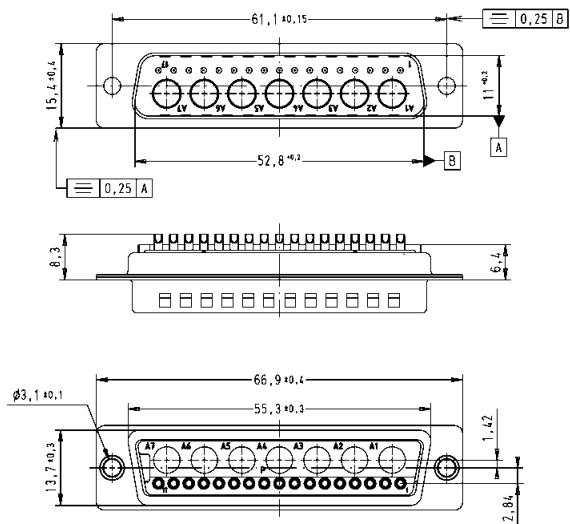

Solder cup termination for AWG 20 (0.5 mm²)

Female connectors

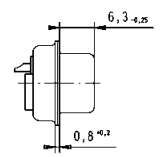
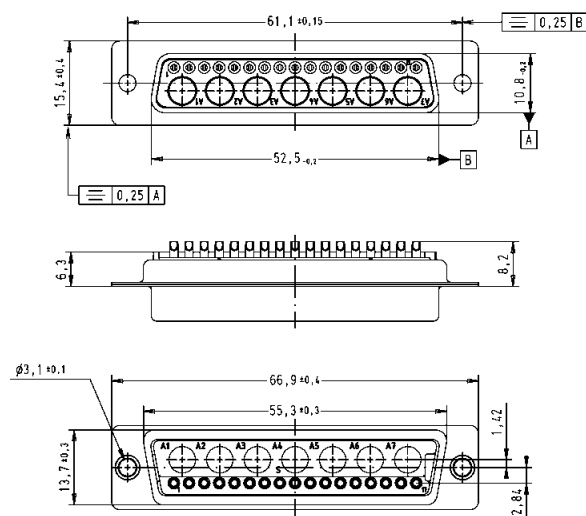

Solder cup termination for AWG 20 (0.5 mm²)

Dimensions in mm

¹⁾ Explanations see page 05.51
²⁾ S4 = 0.76 µm Au or PdNi equivalent
 Board drillings see pages 05.78 ff

Order special contacts separately. See pages 05.69 ff

Number of contacts

36-43



Mixed shells with pre-mounted signal solder cup contacts

Identification	No. of contacts ¹⁾	Part number			
		male connectors		female connectors	
		Performance level 3	S4 ²⁾	Performance level 3	S4 ²⁾
	36W4	09 69 511 7364	09 69 511 5364	09 69 501 7364	09 69 501 5364
	43W2	09 69 511 7432	09 69 511 5432	09 69 501 7432	09 69 501 5432

Male connectors

36W4

43W2

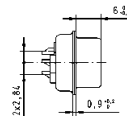
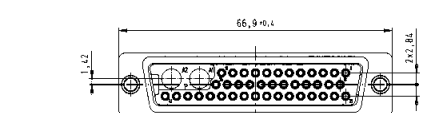
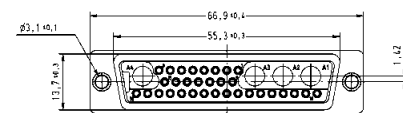
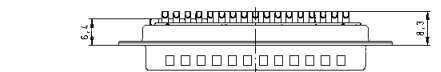
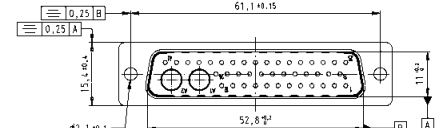
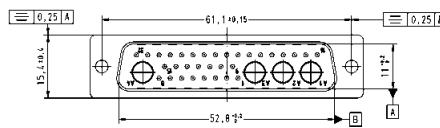

Solder cup termination for AWG 20 (0.5 mm²)

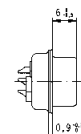

Female connectors

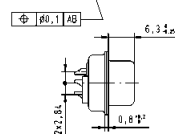
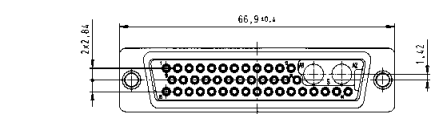
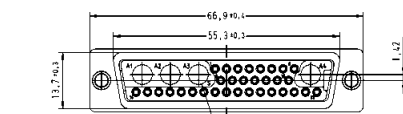
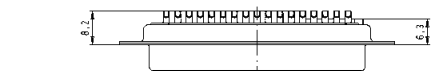
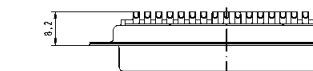
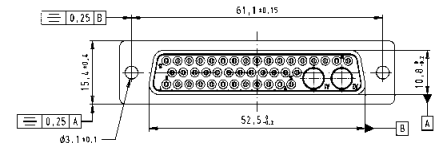
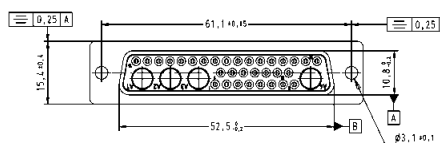

Solder cup termination for AWG 20 (0.5 mm²)

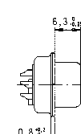

Dimensions in mm

¹⁾ Explanations see page 05.51
²⁾ S4 = 0.76 µm Au or PdNi equivalent
 Board drillings see pages 05.78 ff

Order special contacts separately. See pages 05.69 ff

D-Sub

Number of contacts

2-8



Shells without signal contacts for cable applications

Identification	No. of contacts ¹⁾	Part number	
		male connectors	female connectors
	2W2	09 69 110 0522	09 69 100 0522
	3W3	09 69 210 0033	09 69 200 0033
	5W5	09 69 310 0055	09 69 300 0055
	7W7	09 69 410 0077	09 69 400 0077
	8W8	09 69 410 0088	09 69 400 0088

Male connectors

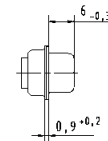
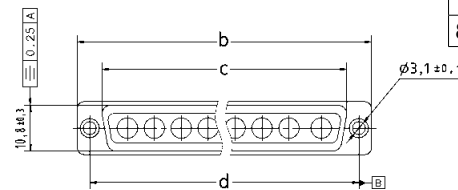
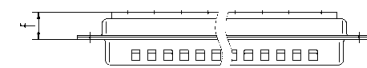
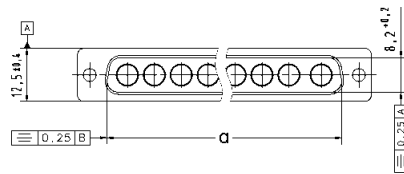

	a	b	c	d	e	f	g
2W2	16.9	30.8	—	25.00	16.4	8.7	8.6
3W3	25.2	39.1	27.5	33.30	24.6	6.4	6.3
5W5	38.9	53.0	41.3	47.04	38.3	6.4	6.3
7W7	55.3	69.3	57.7	63.50	54.9	6.4	6.3
8W8	55.3	69.3	57.7	63.50	54.8	6.4	6.3

Female connectors

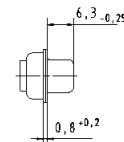
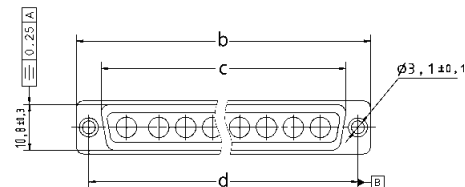
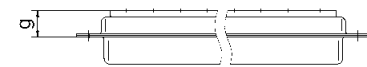
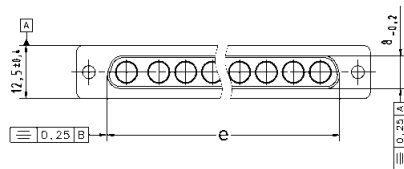

Dimensions in mm

¹⁾ Explanations see page 05.51
Board drillings see pages 05.78 ff
Order special contacts separately. See pages 05.69 ff

Number of contacts

2



Coded shells without signal contacts for cable applications

Identification	No. of contacts ¹⁾	Part number	
		male connector	female connector
	2W2C	09 69 110 0022	09 69 100 0022

Male connectors

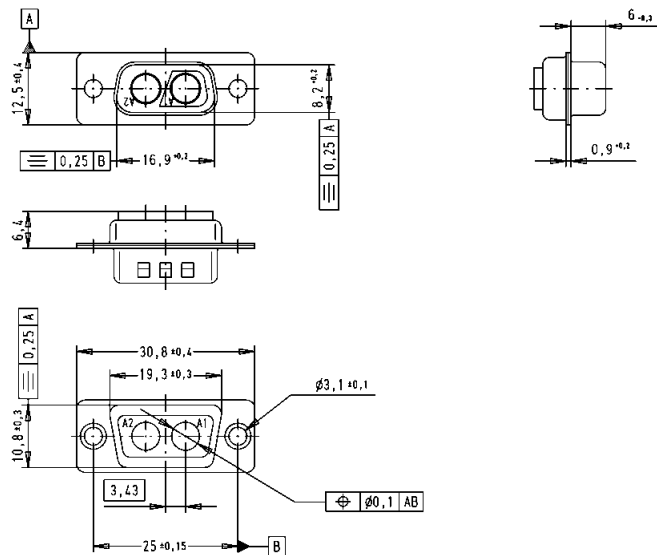

Female connectors

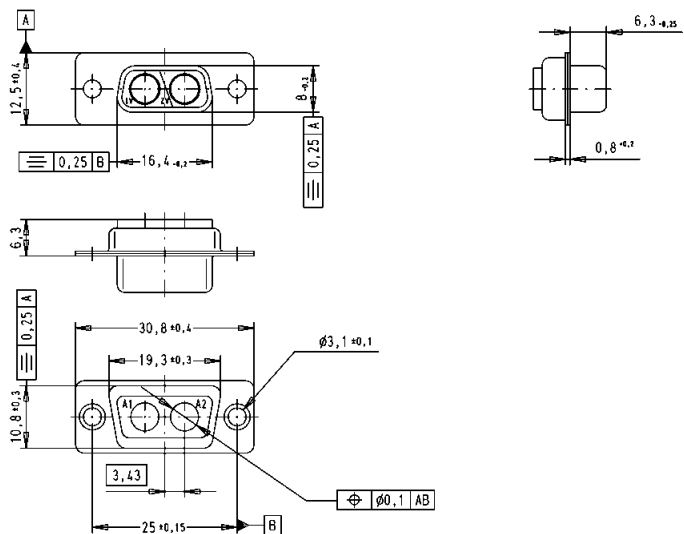

Dimensions in mm

¹⁾ Explanations see page 05.51
 Board drillings see pages 05.78 ff
 Order special contacts separately. See pages 05.69 ff

Number of contacts

3



Coded shells without signal contacts for cable applications

Identification	No. of contacts ¹⁾	Part number	
		male connector	female connector
	3W3C	09 69 210 0633	09 69 200 0633

Male connectors

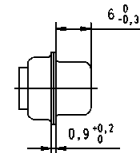
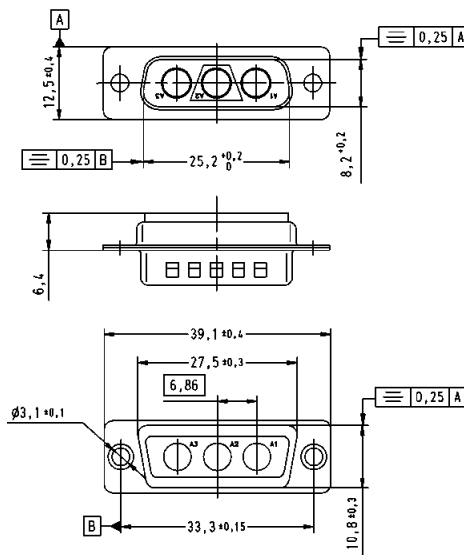

detail: polarization feature

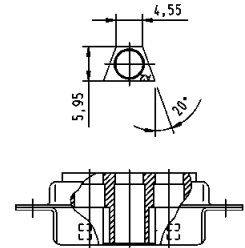

Female connectors

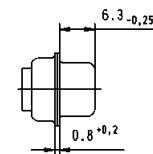
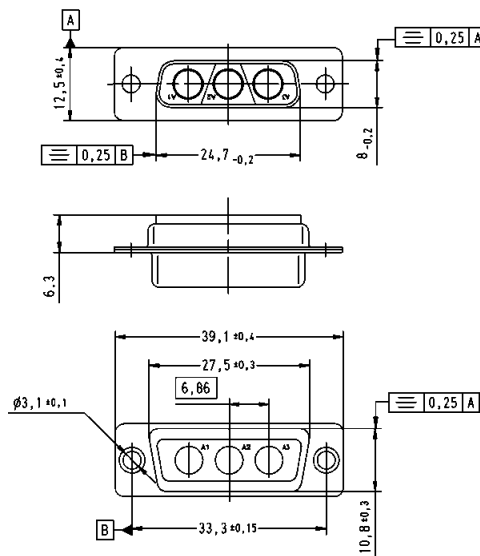

detail: polarization feature

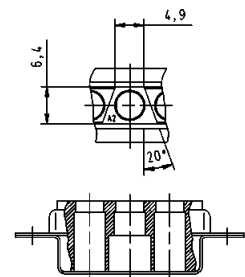

Dimensions in mm

¹⁾ Explanations see page 05.51
Board drillings see pages 05.78 ff
Order special contacts separately. See pages 05.69 ff

Number of contacts

7-27



Mixed shells for signal crimp contacts

Identification	No. of contacts ¹⁾	Part number	
		male connectors	female connectors
	7W2	09 69 212 0072	09 69 202 0072
	17W2	09 69 312 0172	09 69 302 0172
	21WA4	09 69 412 0214	09 69 402 0214
	27W2	09 69 412 0272	09 69 402 0272

Male connectors

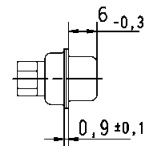
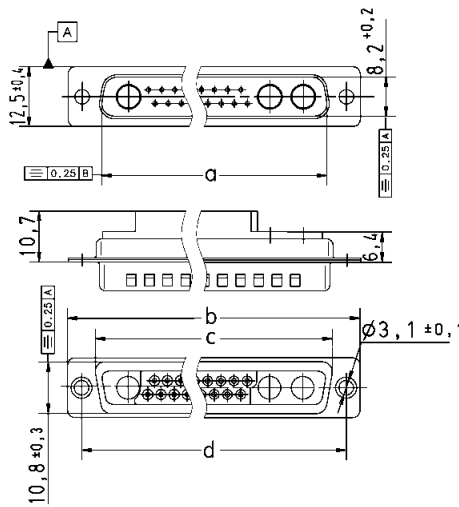

	a	b	c	d	e
7W2	25.2	39.1	27.5	33.30	24.7
17W2	38.9	53.0	41.3	47.04	38.5
21WA4	55.3	69.3	57.7	63.50	54.9
27W2	56.3	69.3	-	63.50	54.9

Female connectors

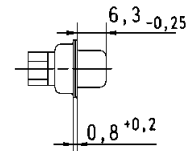
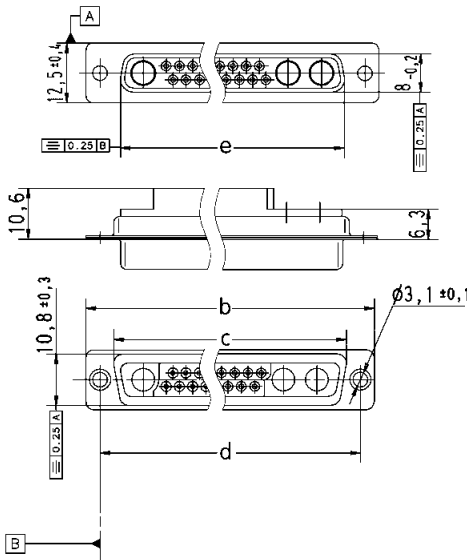

Dimensions in mm

¹⁾ Explanations see page 05.51
 Board drillings see pages 05.78 ff
 Order special contacts separately. See pages 05.69 ff

D-Sub

Number of contacts

13-25



Mixed shells for signal crimp contacts

Identification	No. of contacts ¹⁾	Part number	
		male connectors	female connectors
	13W3	09 69 312 0133	09 69 302 0133
	25W3	09 69 412 0253	09 69 402 0253

Male connectors

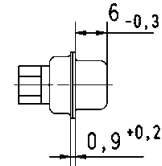
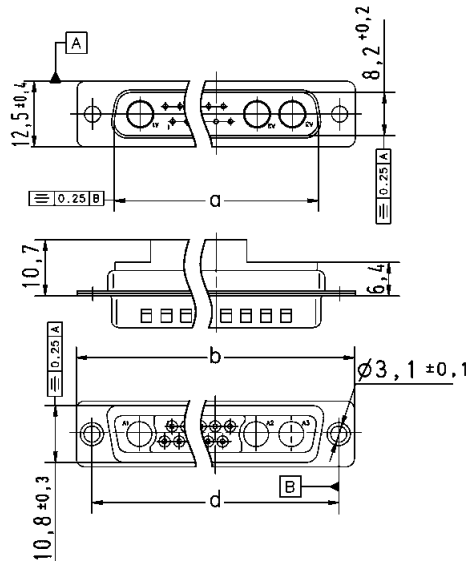

	a	b	d	e
13W3	38.9	53.0	47.04	38.5
25W3	55.3	69.3	63.50	54.9

Female connectors

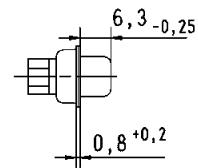
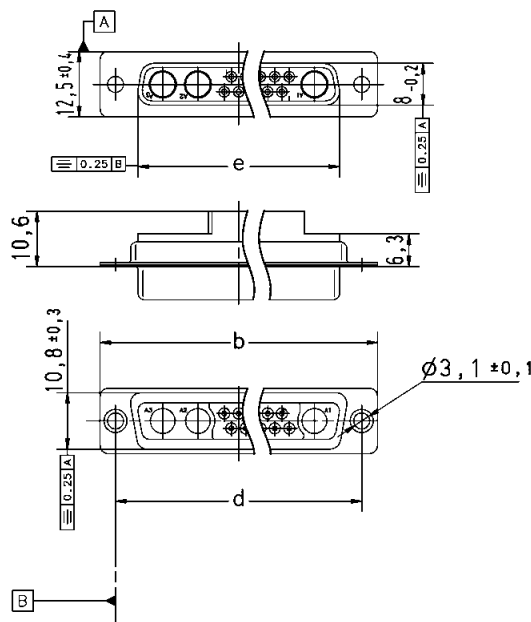

Dimensions in mm

D-Sub

¹⁾ Explanations see page 05.51
 Board drillings see pages 05.78 ff
 Order special contacts separately. See pages 05.69 ff

Number of contacts

11-21



Mixed shells for signal crimp contacts

Identification	No. of contacts ¹⁾	Part number	
		male connectors	female connectors
	11W1	09 69 212 0111	09 69 202 0111
	21W1	09 69 312 0211	09 69 302 0211

Male connectors

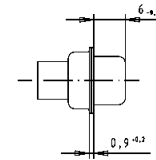
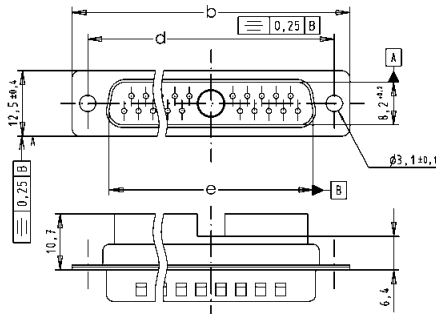

	a	b	c	d	e
11W1	24.7	39.1	27.5	33.30	25.2
21W1	38.5	53.0	41.3	47.04	38.9

Female connectors

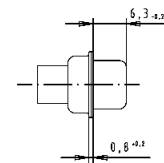
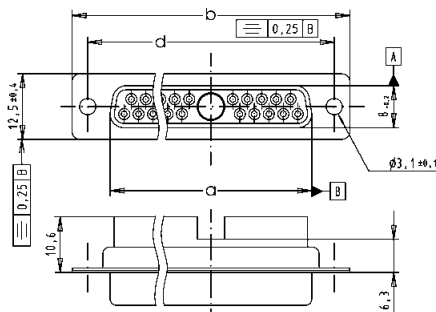

Dimensions in mm

¹⁾ Explanations see page 05.51
 Order special contacts separately. See pages 05.69 ff
 Board drillings see pages 05.78 ff

D-Sub

Number of contacts

36

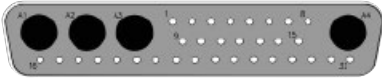

Mixed shells for signal crimp contacts

Identification	No. of contacts ¹⁾	Part number	
		male connector	female connector
	36W4	09 69 512 0364	09 69 502 0364

Male connectors

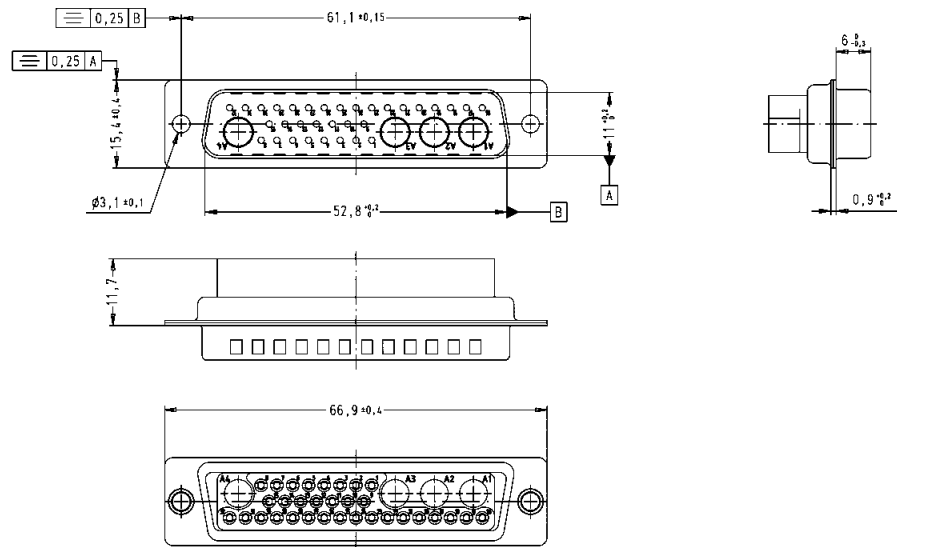

Female connectors

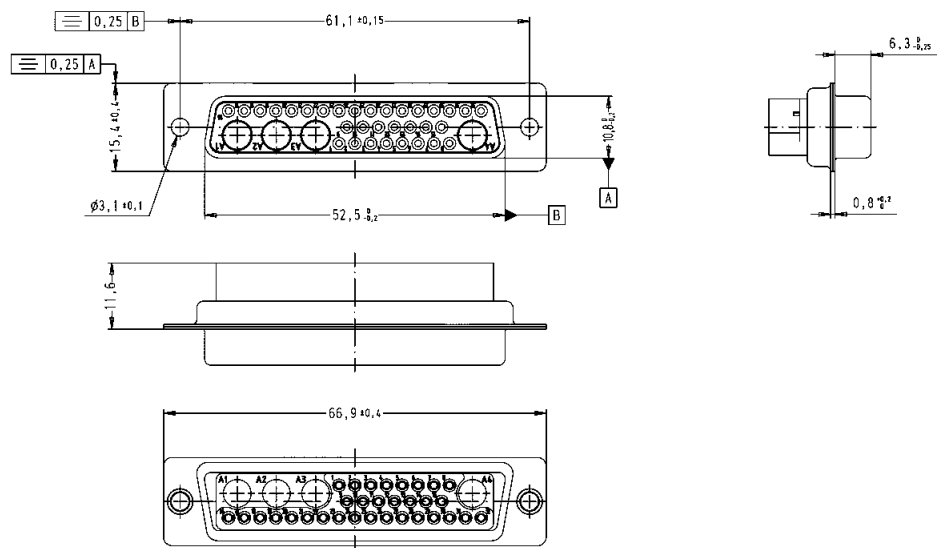

Dimensions in mm

¹⁾ Explanations see page 05.51
 Board drillings see pages 05.78 ff
 Order special contacts separately. See pages 05.69 ff

	Signal contacts see page 05.70	Coaxial contacts see pages 05.74 – 05.76	Power contacts see pages 05.72 + 05.73	High voltage contacts see page 05.71	Pneumatic contacts see page 05.77
Working current	5 A	2 A	10 A, 20 A, 30 A or 40 A	10 A DC	–
Test voltage $U_{r.m.s.}$	–	750 V / 50 Hz	–	4 kV / 50 Hz	–
Operating voltage	–	–	–	≤ 3 kV	–
Contact resistance	–	≤ 10 mΩ (inner and outer conductor)	≤ 1 mΩ	≤ 3 mΩ (outer conductor)	–
Impedance	–	50 / 75 Ω	–	–	–
Frequency range	–	0 - 2 GHz	–	–	–
Temperature range	–	-55 °C ... +135 °C	-55 °C ... +155 °C	-55 °C ... +125 °C	-10 °C ... +60 °C
Mating cycles					
high performance level	≥ 500	≥ 500	≥ 500	–	–
standard performance level	–	≥ 200	≥ 200	≥ 500	–
Mating force	≤ 3.4 N	≤ 7 N/mated pair	≤ 7 N/mated pair	≤ 5 N	–
Unmating force	≥ 0.2 N	≤ 7 N/mated pair	appr. 5 N	appr. 2.5 N	–
Max. pressure	–	–	–	–	7 bars at 20 °C
Materials					
Contacts	Copper alloy	Copper alloy	Copper alloy	Copper alloy	German silver
Plating for PCB applications*					
Mating side / terminating side	0.76 μm Au / 0.76 μm Au		0.76 μm Au / 5 μm Sn or 0.2 μm Au / 5 μm Sn	1.3 μm Au / 1.3 μm Au	–
Inner conductor mating side / terminating side	–	1.3 μm Au / 1.3 μm Au or 0.2 μm Au / 0.2 μm Au	–	–	–
Outer conductor mating side / terminating side	–	0.76 μm Au / 0.2 μm Au or 0.2 μm Au / 5 μm Sn	–	–	–
Retaining clip	–	Copper alloy	Copper alloy	PI	–
Insulator	–	PBFE/PBTP/PI	–	PTFE	–
O-ring	–	–	–	–	Vitton

Technical characteristics for shells see page 05.04

* **High performance** or standard performance level



Turned crimp contacts

Identification	Wire gauge (mm ²)	Part number		
		Male contacts	Female contacts	High-end female contacts
		Performance level 1*	Performance level 1*	Performance level 1*
Individual contacts ¹⁾	AWG 22-18 0.33-0.82	09 67 000 3576	09 67 000 3476	09 67 000 3676
	AWG 24-20 0.25-0.52	09 67 000 8576	09 67 000 8476	09 67 000 8676
	AWG 26-22 0.13-0.33	09 67 000 5576	09 67 000 5476	09 67 000 5676
	AWG 28-24 0.09-0.25	09 67 000 7576	09 67 000 7476	09 67 000 7676

¹⁾ Minimum order 100 pieces or multiples of 100

Male contacts

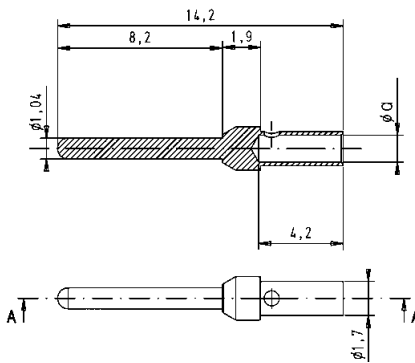

	a	groove
AWG 22-18	1.34	none
AWG 24-20	1.13	1
AWG 26-22	0.88	2
AWG 28-24	0.64	3

Female contacts

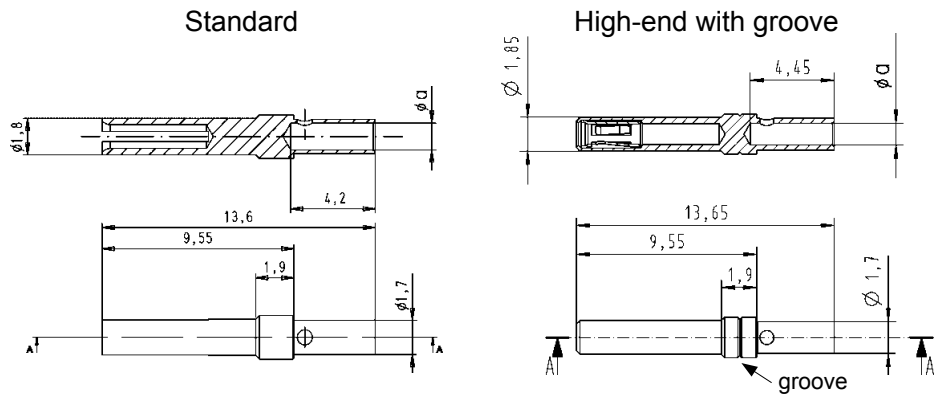

* Performance level 1 as per CECC 75301-802, 500 mating cycles, 10 days 4 mixed gas test – IEC 60512
Use crimp tool with the part no. 09 99 000 0501 and the locator with the part no. 09 99 000 0531. Details see chapter 20



High voltage contacts for cable applications

Identification	Wire gauge (mm ²)	Part number	
		Male contacts Plating: 1.3 µm Au ¹⁾	Female contacts Plating: 1.3 µm Au ¹⁾
Straight versions with solder termination	AWG 24 - 20 0.25 - 0.56	09 69 281 2550	09 69 181 2550
	with crimp termination ²⁾	AWG 30 - 24 0.05 - 0.25	09 69 282 2550
Right angled versions with solder termination	AWG 24 - 20 0.25 - 0.56	09 69 681 2550	09 69 581 2550

D-Sub

Identification	Male contacts	Female contacts
Straight versions with solder termination		
with crimp termination ²⁾		
Right angled versions with solder termination		

Dimensions in mm

¹⁾ for mating and terminating side
²⁾ Tooling see chapter 20



Straight power contacts for cable applications

Identification	Rating (A)	Part number	
Performance levels 		Performance level 3	S4 ¹⁾
Solder version			
Male contacts	10 20 30 40	09 69 281 7420 09 69 281 7421 09 69 281 7422 09 69 281 7423	09 69 281 5420 09 69 281 5421 09 69 281 5422 09 69 281 5423
Short male contacts	20 40	09 69 281 7821 09 69 281 7823	09 69 281 5821 09 69 281 5823
Female contacts	10 20 30 40	09 69 181 7420 09 69 181 7421 09 69 181 7422 09 69 181 7423	09 69 181 5420 09 69 181 5421 09 69 181 5422 09 69 181 5423
Short female contacts	20 40	09 69 181 7821 09 69 181 7823	09 69 181 5821 09 69 181 5823
Crimp version ²⁾			
Male contacts	10 20 30 40	09 69 282 7420 09 69 282 7421 09 69 282 7422 09 69 282 7423	09 69 282 5420 09 69 282 5421 09 69 282 5422 09 69 282 5423
Short male contacts	20 40	09 69 282 7821 09 69 282 7823	09 69 282 5821 09 69 282 5823
Female contacts	10 20 30 40	09 69 182 7420 09 69 182 7421 09 69 182 7422 09 69 182 7423	09 69 182 5420 09 69 182 5421 09 69 182 5422 09 69 182 5423
Short female contacts	20 40	09 69 182 7821 09 69 182 7823	09 69 182 5821 09 69 182 5823

D-Sub

¹⁾ S4 = 0.76 µm Au or PdNi equivalent
²⁾ Tooling see chapter 20

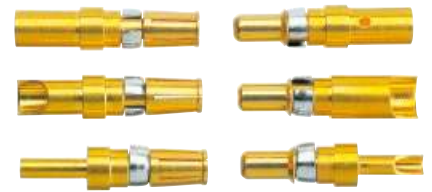

Straight power contacts for cable applications

Identification

Drawing

Dimensions in mm

Male contacts

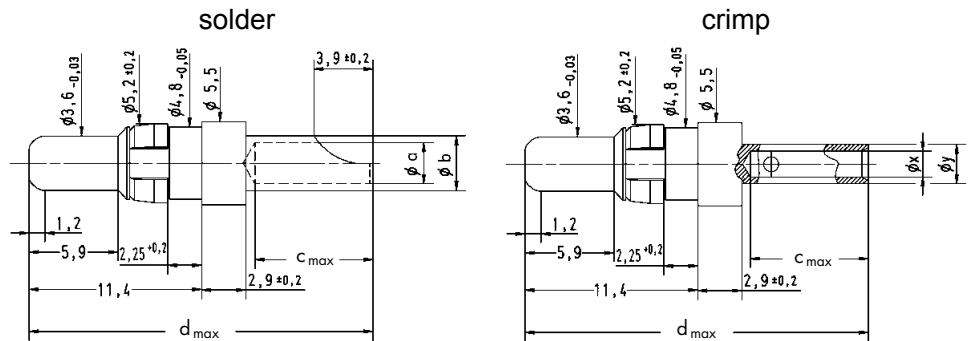

	Rating (A)	$\phi a -0.1$	$\phi b \pm 0.05$	C_{max}	d_{max}	e	$\phi x -0.1$	$\phi y \pm 0.05$	AWG
	10	1.8	2.54	7.8	23	7.5	1.7	2.6	16 - 20
	20	2.7	3.63	7.8	23	7.5	2.6	3.6	12 - 14
short version	20	2.7	3.63	4.7	17.4	4.5	2.6	3.6	12 - 14
	30	3.5	4.40	7.8	23	7.5	3.7	4.7	10 - 12
	40	4.8	5.50	7.8	23	7.5	4.6	5.8	8 - 10
short version	40	4.8	5.50	6.4	20	6.1	4.6	5.8	8 - 10

	Rating (A)	min./max. conductor ϕ	min./max. conductor cross section [mm ²]
	10	0.9 to 1.7	0.64 to 2.27
	20	1.8 to 2.6	2.54 to 5.31
short version	20	1.8 to 2.6	2.54 to 5.31
	30	2.2 to 3.7	3.80 to 10.75
	40	2.9 to 4.6	6.61 to 16.62
short version	40	2.9 to 4.6	6.61 to 16.62

Female contacts

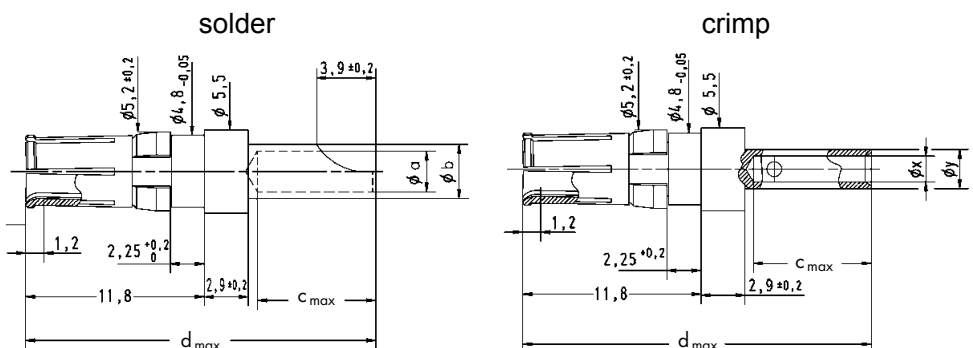

stripping dimensions for male and female contacts

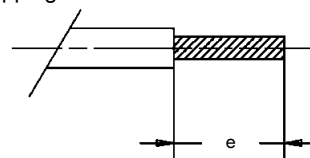



Coaxial contacts for cable applications

Identification	Impedance (Ω)	Part number						
		Straight male contacts		Straight female contacts				
		Performance level 3	S4 ¹⁾	Performance level 3	S4 ¹⁾			
Solder / crimp contact								
for cables RG 174 U, 188 AU, 316 U	50	09 69 281 7140	09 69 281 5140	09 69 181 7140	09 69 181 5140			
for cables RG 178 BU, 196 AU, 404 U	50	09 69 281 7141	09 69 281 5141	09 69 181 7141	09 69 181 5141			
for cables RG 58 CU, 141 AU	50	09 69 281 7143	09 69 281 5143	09 69 181 7143	09 69 181 5143			
for cables RG 179 BU, 187 AU	75	09 69 281 7230	09 69 281 5230	09 69 181 7230	09 69 181 5230			
for cables RGD 179	75	09 69 281 7233	09 69 281 5233	09 69 181 7233	09 69 181 5233			
Crimp / crimp contact								
for cables RG 174 U, 188 AU, 316 U	50	09 69 282 7140	09 69 282 5140	09 69 182 7140	09 69 182 5140			
for cables RG 179 BU, 187 AU	75	09 69 282 7230	09 69 282 5230	09 69 182 7230	09 69 182 5230			
for cables RG 59	75	09 69 282 7232	09 69 282 5232	09 69 182 7232	09 69 182 5232			
for cables RGD 179	75	09 69 282 7233	09 69 282 5233	09 69 182 7233	09 69 182 5233			
Harnessing dimensions (mm)								
	Part number	Ø A	Ø B	Ø C	Ø D	E	F	G
	09 69 181 x140 09 69 281 x140	0.85	1.9	2.3	3.2	9.5	5.0	3.0
	09 69 181 x141 09 69 281 x141	0.85	1.2	1.4	2.3	9.5	5.0	3.0
	09 69 181 x143 09 69 281 x143	1.00	3.0	4.4	5.2	9.5	5.0	3.0
	09 69 181 x230 09 69 281 x230	0.50	1.9	2.3	3.2	9.5	5.0	3.0
	09 69 182 x140 09 69 282 x140	0.60	1.9	2.4	3.2	9.0	5.0	3.0
	09 69 182 x230 09 69 282 x230	0.60	1.9	2.4	3.2	9.0	5.0	3.0
	09 69 182 x232 09 69 282 x232	0.95	3.8	5.1	6.2	9.0	4.3	3.7
	09 69 181 x233 09 69 281 x233	0.50	1.9	2.6	3.5	9.5	5.0	3.0
	09 69 182 x233 09 69 282 x233	0.60	1.9	2.6	3.5	9.3	4.3	3.0

D-Sub

¹⁾ S4 = 0.76 µm Au or PdNi equivalent
Dimensions see pages 05.75 and 05.76
Tooling see chapter 20



Coaxial contacts for cable applications

Identification

Drawing

Dimensions in mm

Male contacts

Part number	ø a	ø b	ø c	ø d
09 69 281 x140	0.85	1.9	2.6	3.2
09 69 281 x141	0.85	1.2	1.7	2.3
09 69 281 x230	0.50	1.9	2.6	3.2

Part number	ø a	ø b	ø c	ø d
09 69 281 x143	1.0	3.0	4.4	5.2

Part number	ø a	ø b	ø c	ø d
09 69 281 x233	0.5	1.9	2.6	3.5

Part number	ø a	ø b	ø c	ø d	ø e
09 69 282 x140	0.6	1.9	2.6	3.2	3.8
09 69 282 x230	0.6	1.9	2.6	3.2	3.8
09 69 282 x233	0.6	1.9	2.6	3.5	4.4

Part number	ø a	ø b	ø c	ø d
09 69 282 x232	0.95	3.8	5.1	6.2

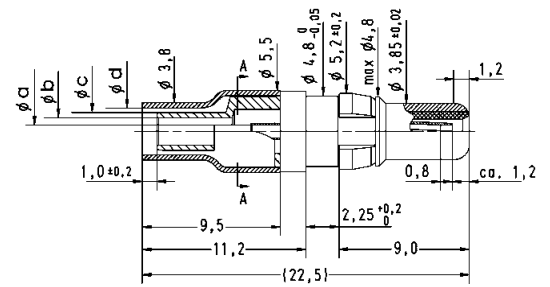

Points of plating thickness measurement

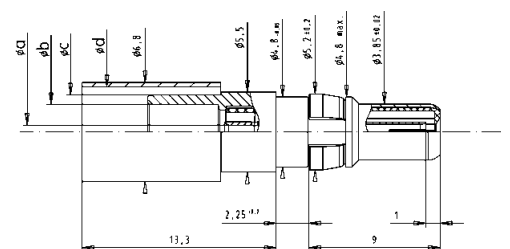
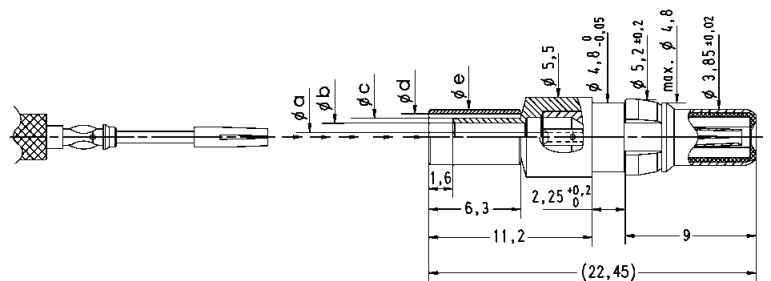
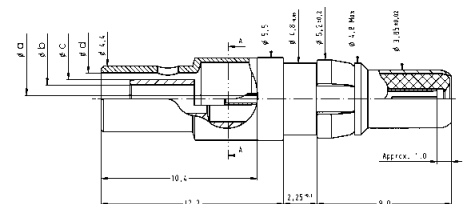
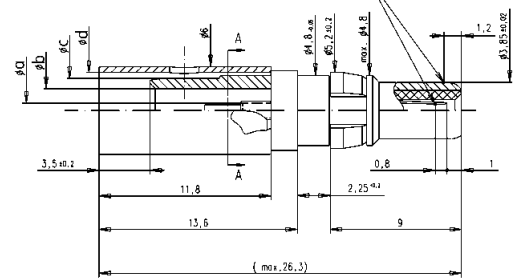



Coaxial contacts for cable applications

Identification

Drawing

Dimensions in mm

Female contacts

Part number	ø a	ø b	ø c	ø d
09 69 181 x140	0.85	1.9	2.6	3.2
09 69 181 x141	0.85	1.2	1.7	2.3
09 69 181 x230	0.50	1.9	2.6	3.2

Part number	ø a	ø b	ø c	ø d
09 69 181 x143	1.0	3.0	4.4	5.2

Part number	ø a	ø b	ø c	ø d
09 69 181 x233	0.5	1.9	2.6	3.5

Part number	ø a	ø b	ø c	ø d	ø e
09 69 182 x140	0.6	1.9	2.6	3.2	3.8
09 69 182 x230	0.6	1.9	2.6	3.2	3.8
09 69 182 x233	0.6	1.9	2.6	3.5	4.4

Part number	ø a	ø b	ø c	ø d
09 69 182 x232	0.95	3.8	5.1	6.2

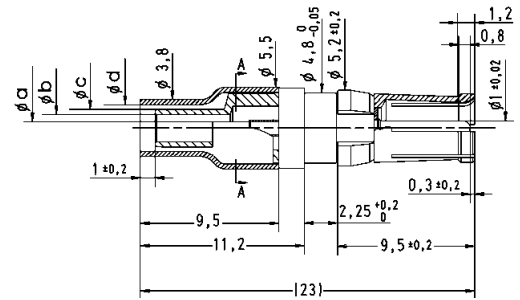

Points of plating thickness measurement

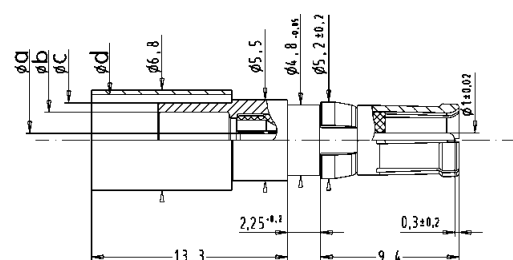
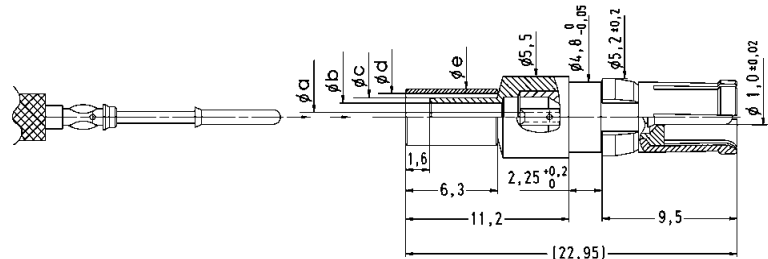
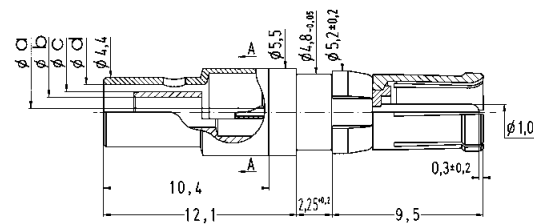
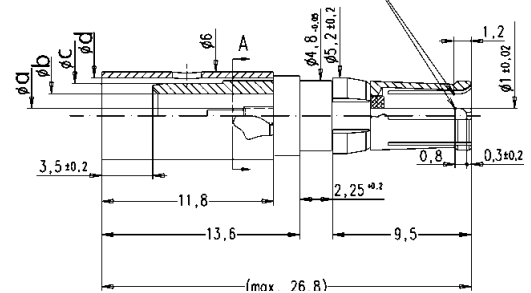



Pneumatic contacts for cable applications

Identification	Inner diameter air tube (mm)	Part number
Male contacts	2	09 69 287 0060
	2.6	09 69 287 0061
	3	09 69 287 0062
	4	09 69 287 0063
Female contacts	2	09 69 187 0060
	2.6	09 69 187 0061
	3	09 69 187 0062
	4	09 69 187 0063

Male contacts

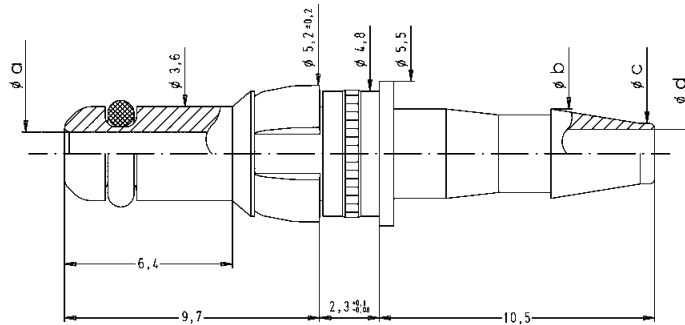

Part number	ϕa	ϕb	ϕc	ϕd
09 69 x87 0060	1.45	2.6	1.5	0.95
09 69 x87 0061	1.65	3.1	2.0	1.65
09 69 x87 0062	1.65	3.4	2.3	1.85
09 69 x87 0063	1.65	4.8	3.7	2.95

Female contacts

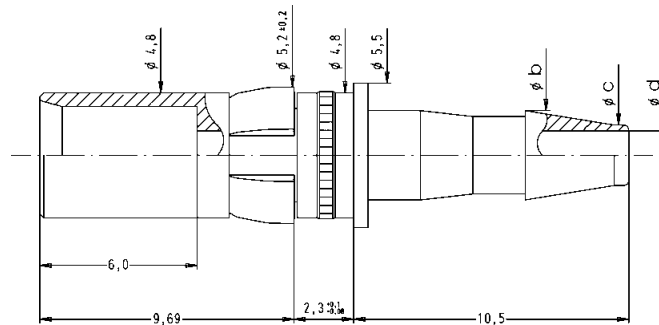

Dimensions in mm

D-Sub

Board drillings for connectors with straight pcb contacts

Pcb hole patterns

In the next pages, the pcb hole pattern is given for the power and the coaxial contact per connector layout. In the case of the power contact, the drilling hole dimension is not mentioned; the table here under provides relevant information according to the current rating of the contact and its version.

Power contact diameter and pcb related drilling diameter

Rating	Straight connectors		Right angled connectors	
	Pin Ø (mm)	Pcb drilling Ø (mm)	Pin Ø (mm)	Pcb drilling Ø (mm)
20 A	2.60	2.9	2.85	3.15
30 A	–	–	3.20	3.50
40 A	3.75	4.0	3.75	4.05

Identification Drawing Dimensions in mm

Male connector*

Power contact

Coaxial contact

2W2 / 2W2C

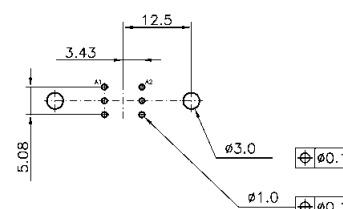
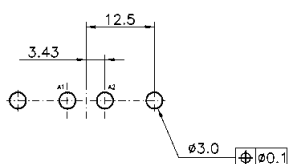

3W3 / 3W3C

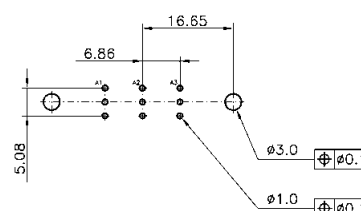
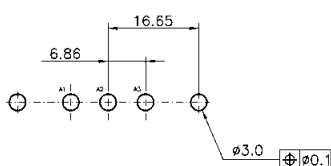

5W1

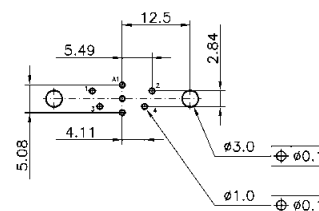
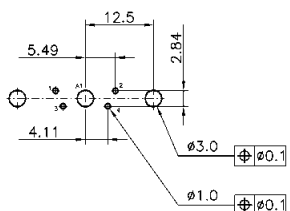

5W5

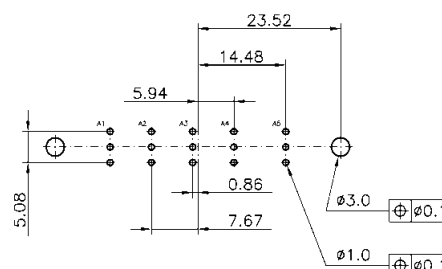
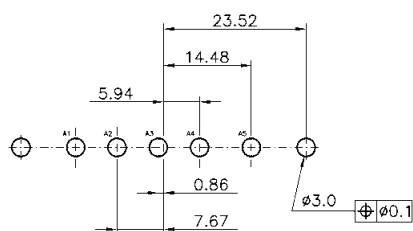

7W2

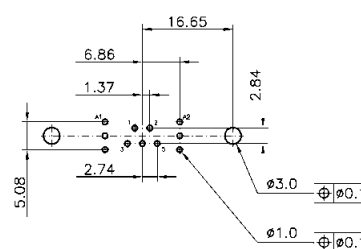
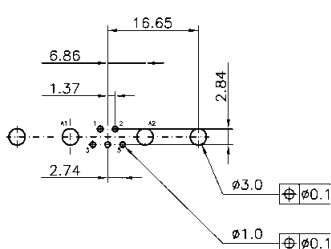

* When using a female connector with straight pcb contacts the board drilling pattern must be mirrored in the Y axis.



Board drillings for connectors with straight pcb contacts

Identification Drawing Dimensions in mm

Male connector*

7W7

Power contact

Coaxial contact

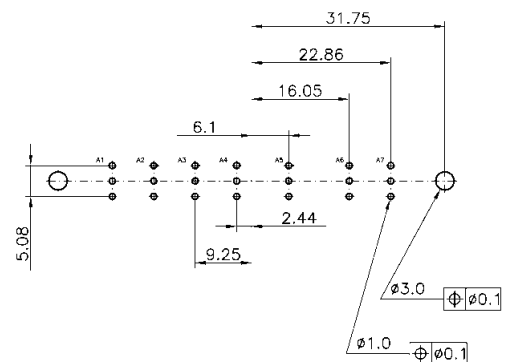
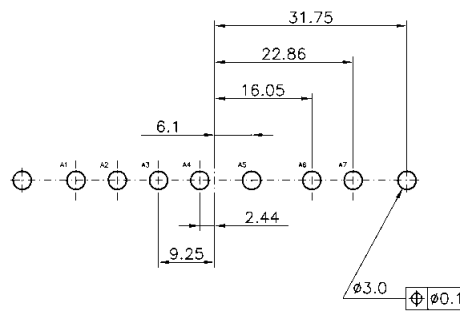

8W8

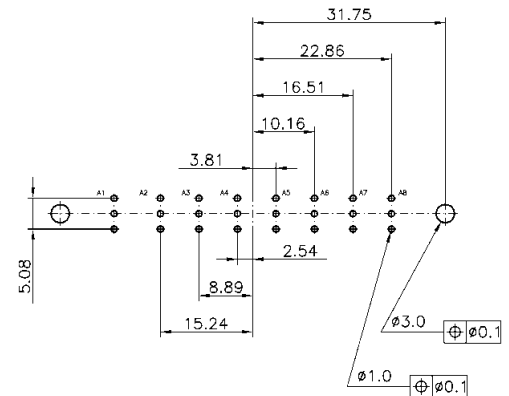
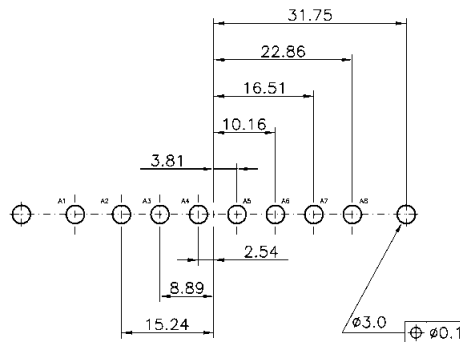

9W4

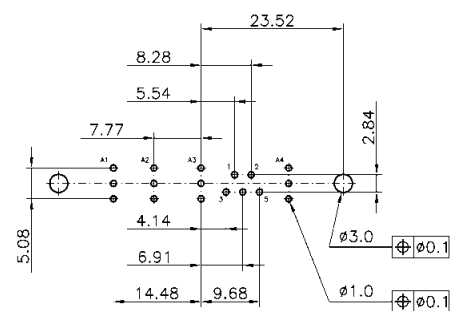
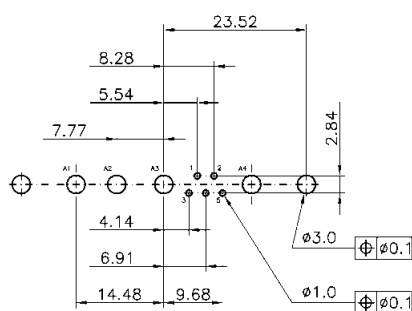

11W1

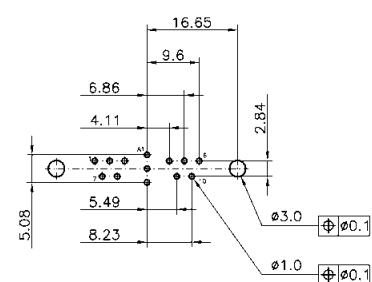
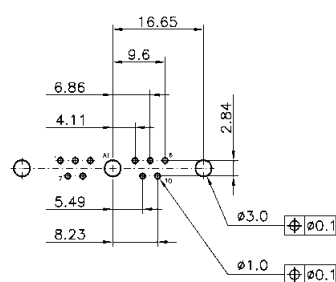

D-Sub

* When using a female connector with straight pcb contacts the board drilling pattern must be mirrored in the Y axis.

Board drillings for connectors with straight pcb contacts

Identification

Drawing

Dimensions in mm

Male connector*

13W3

Power contact

Coaxial contact

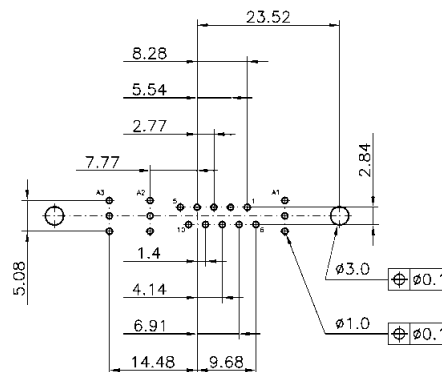
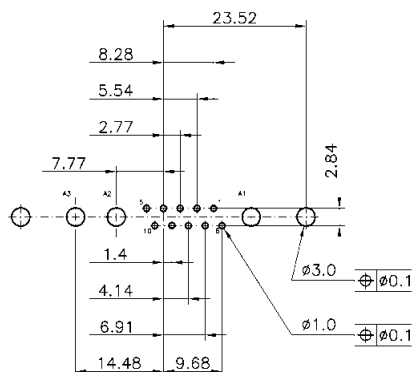

13W6

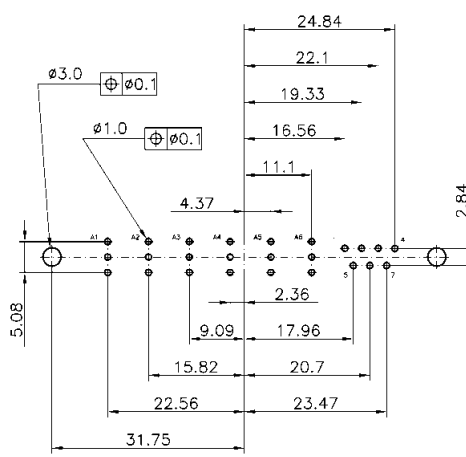
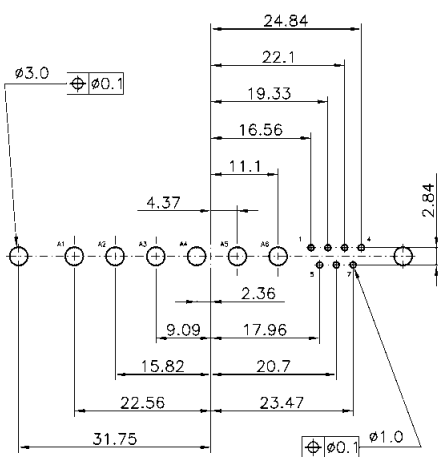

17W2

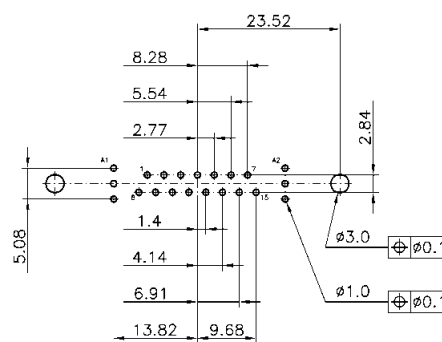
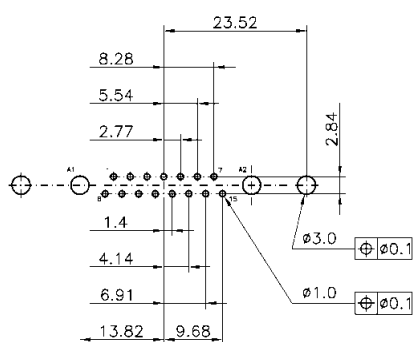

21W1

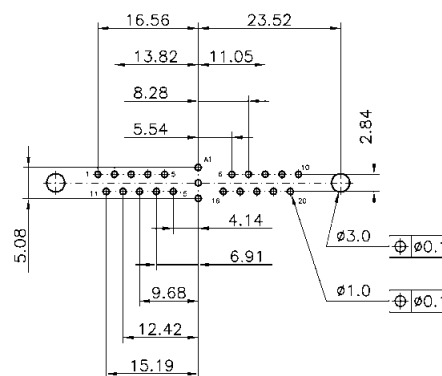
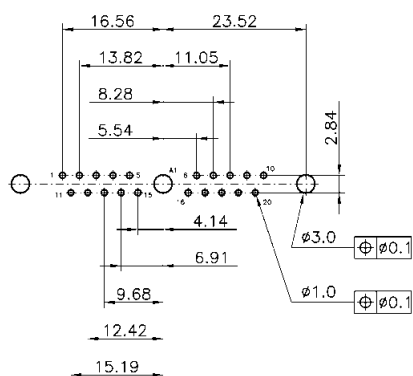

D-Sub

* When using a female connector with straight pcb contacts the board drilling pattern must be mirrored in the Y axis.

Board drillings for connectors with straight pcb contacts

Identification

Drawing

Dimensions in mm

Male connector*

21WA4

Power contact

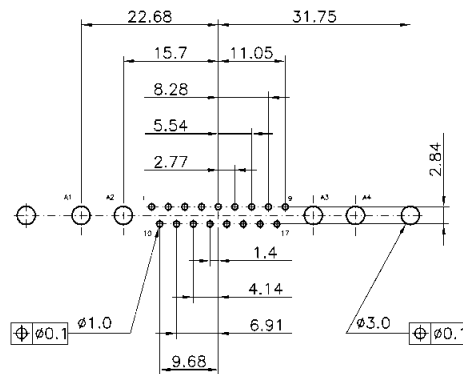

Coaxial contact

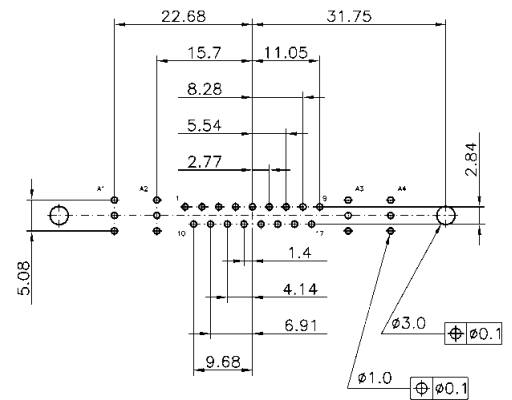

24W7

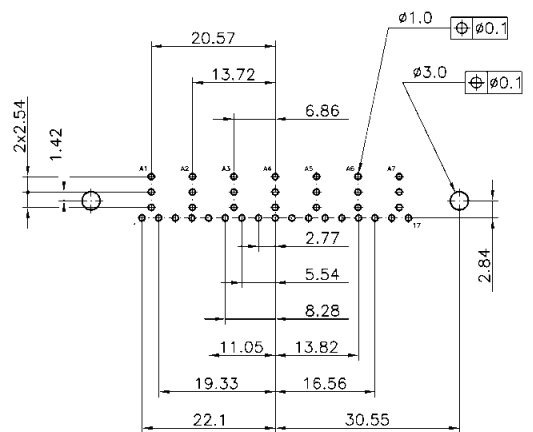
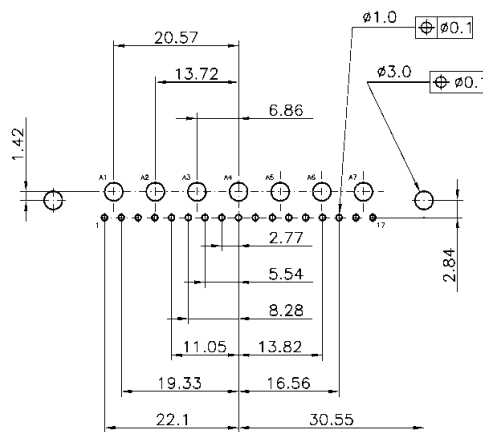

25W3

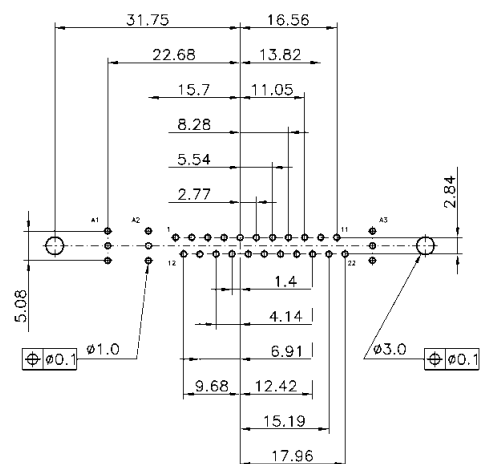
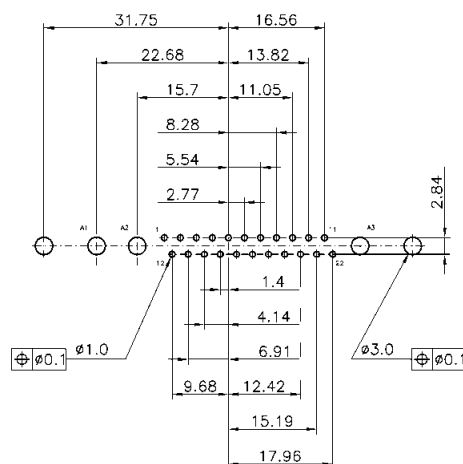

D-Sub

* When using a female connector with straight pcb contacts the board drilling pattern must be mirrored in the Y axis.

Board drillings for connectors with straight pcb contacts

Identification

Drawing

Dimensions in mm

Male connector*

27W2

Power contact

Coaxial contact

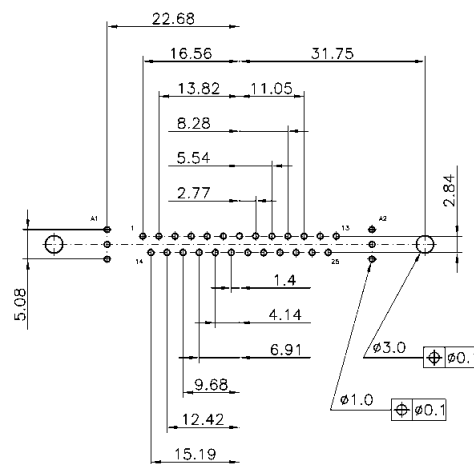
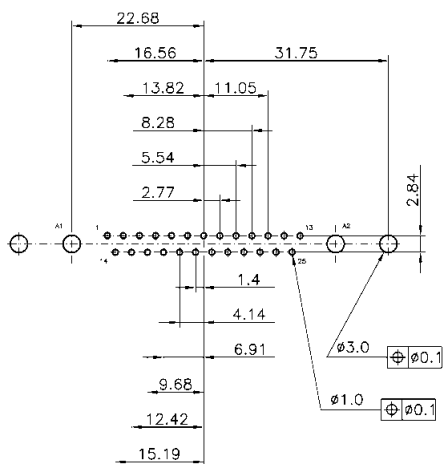

36W4

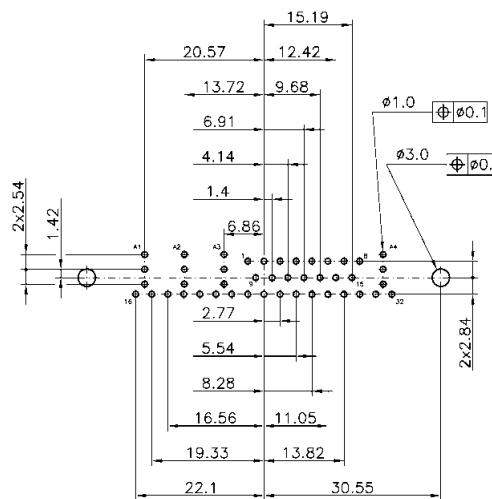
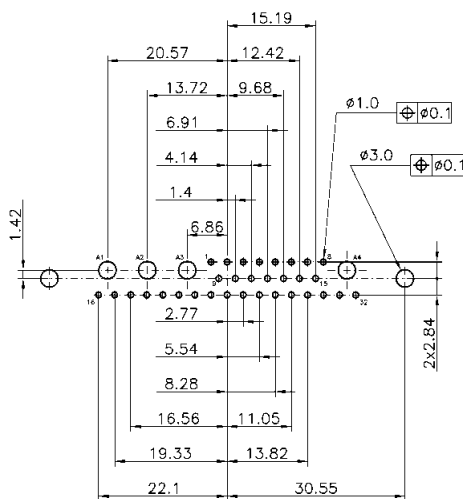

43W2

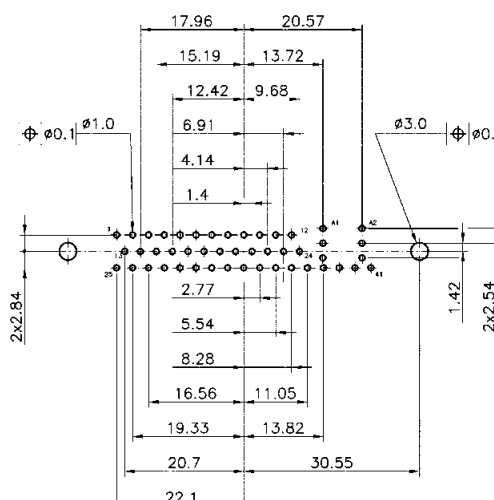
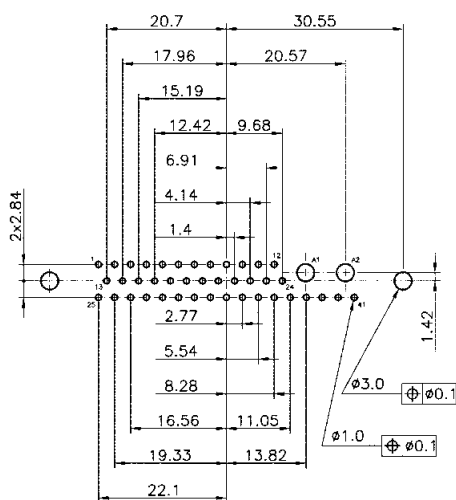

* When using a female connector with straight pcb contacts the board drilling pattern must be mirrored in the Y axis.



Board drillings for connectors with right angled pcb contacts

Identification Drawing Dimensions in mm

Male connector*

Power contact

Coaxial contact

2W2 / 2W2C

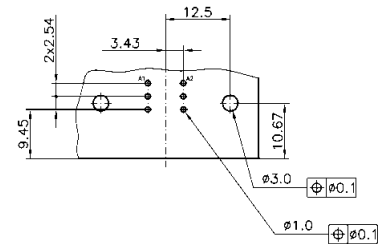
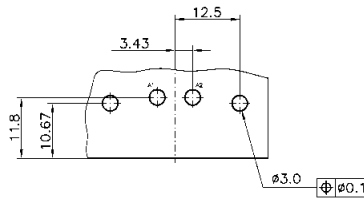

3W3 / 3W3C

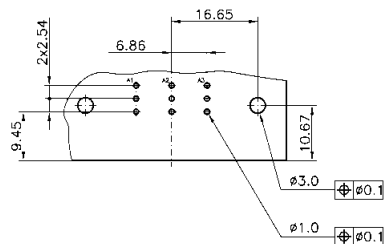
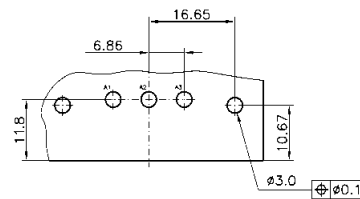

5W1

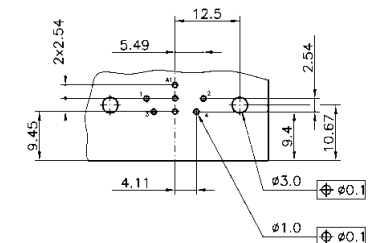
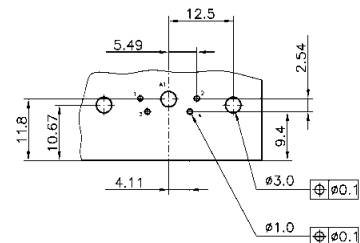

5W5

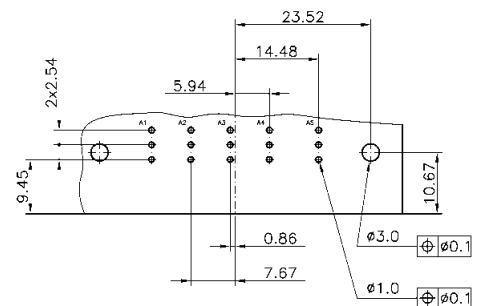
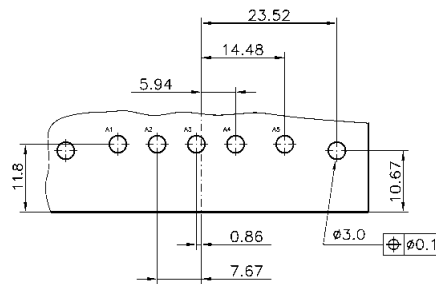

7W2

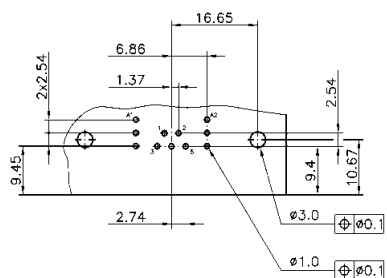
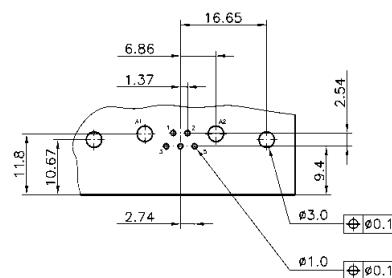

* When using a female connector with right angled pcb contacts the board drilling pattern must be mirrored in the Y axis.

Board drillings for connectors with right angled pcb contacts

Identification

Drawing

Dimensions in mm

Male connector*

7W7

Power contact

Coaxial contact

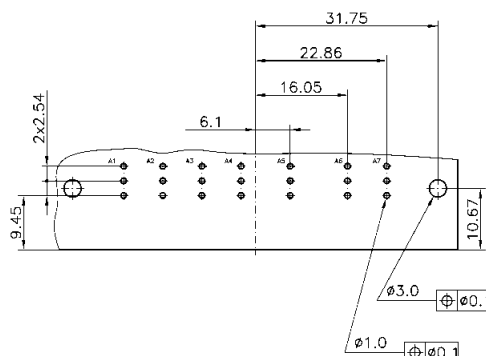
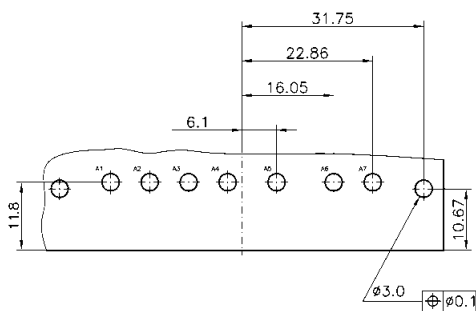

8W8

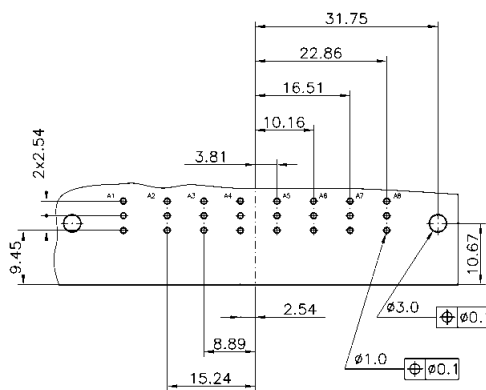
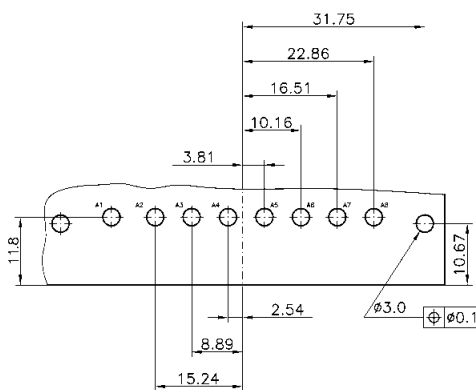

9W4

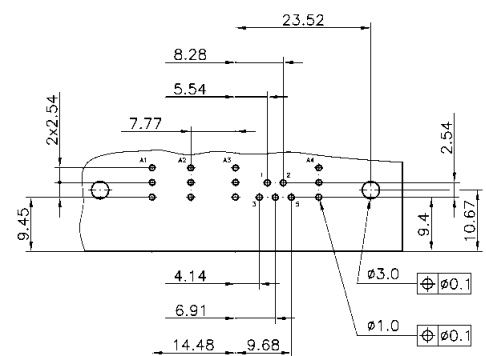
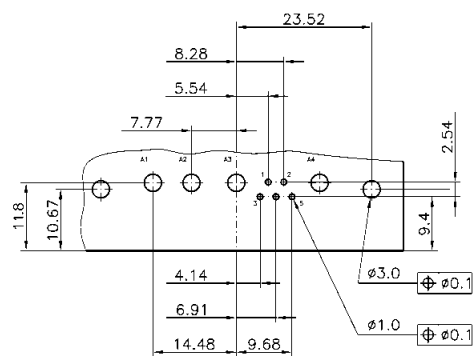

11W1

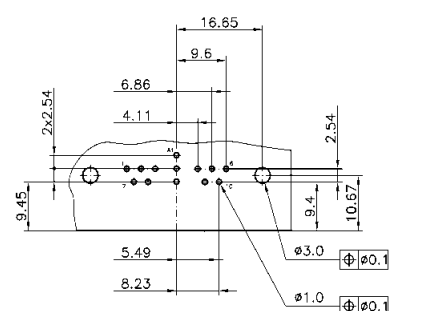
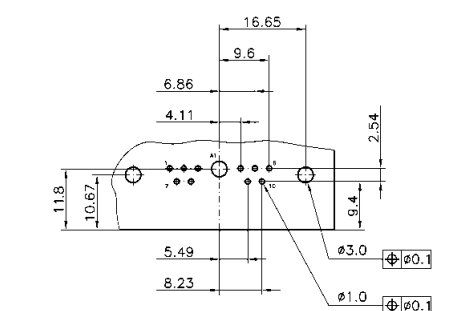

D-Sub

* When using a female connector with right angled pcb contacts the board drilling pattern must be mirrored in the Y axis.

Board drillings for connectors with right angled pcb contacts

Identification

Drawing

Dimensions in mm

Male connector*

13W3

Power contact

Coaxial contact

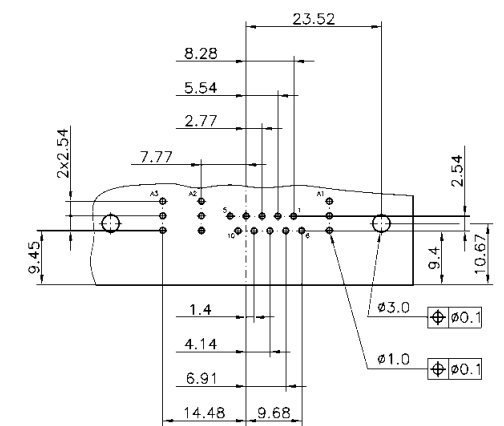
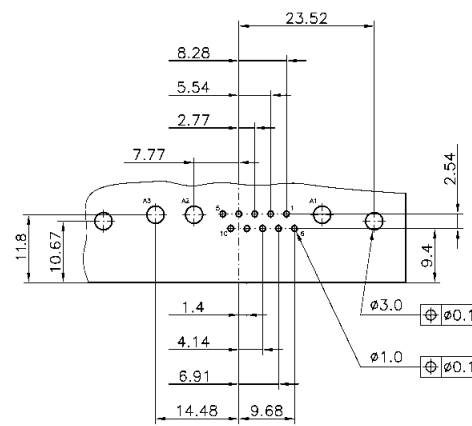

13W6

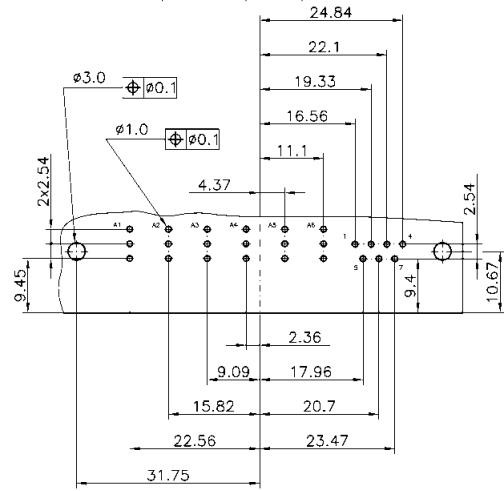
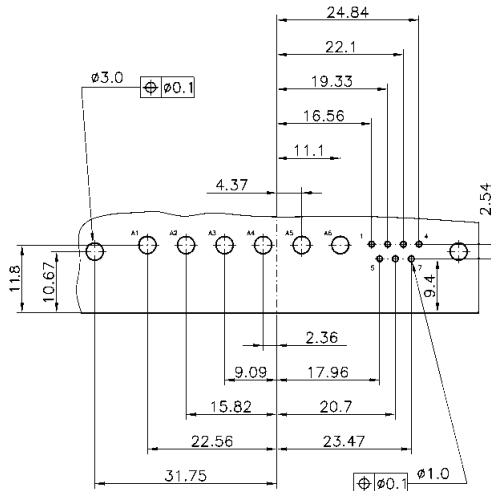

17W2

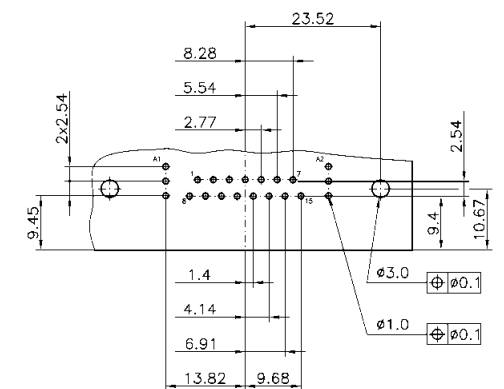
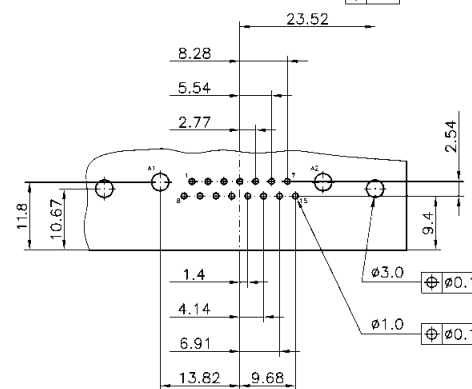

21W1

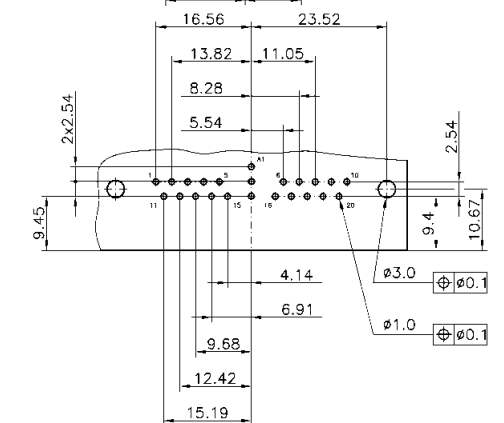
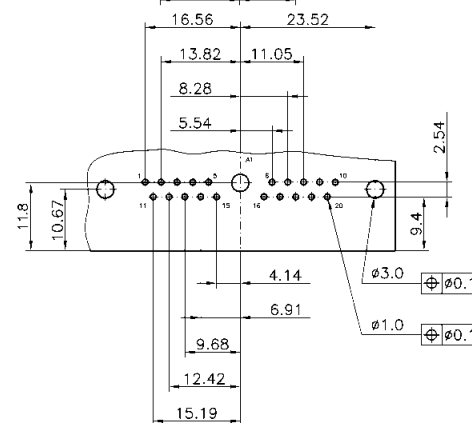

D-Sub

* When using a female connector with right angled pcb contacts the board drilling pattern must be mirrored in the Y axis.

Board drillings for connectors with right angled pcb contacts

Identification

Drawing

Dimensions in mm

Male connector*

21WA4

Power contact

Coaxial contact

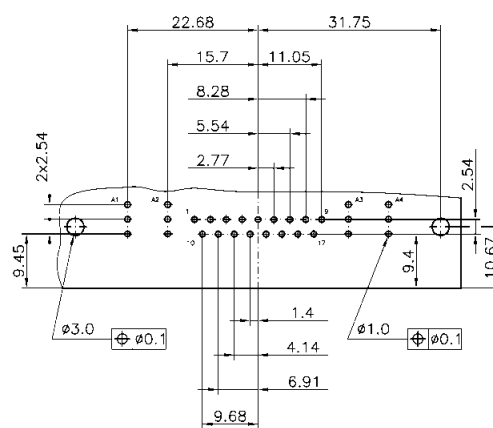
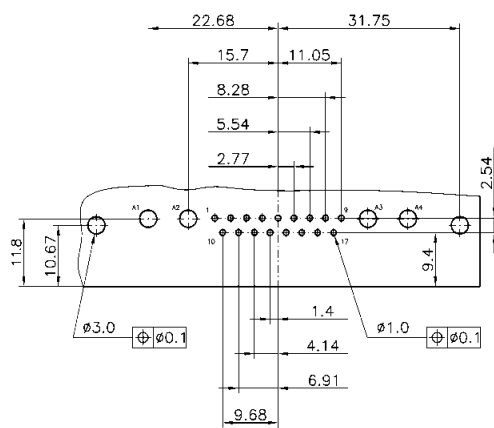

24W7

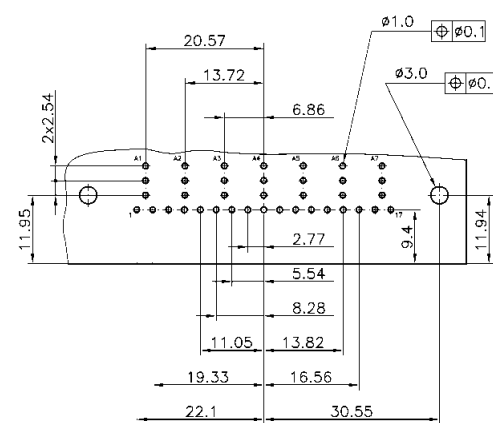
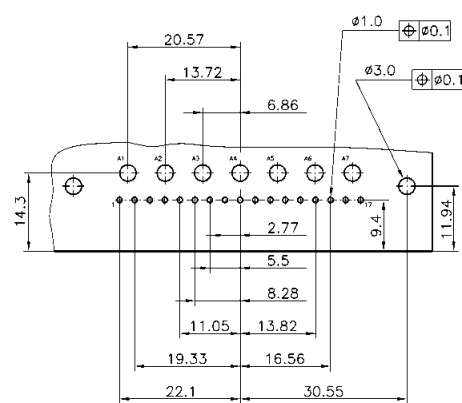

25W3

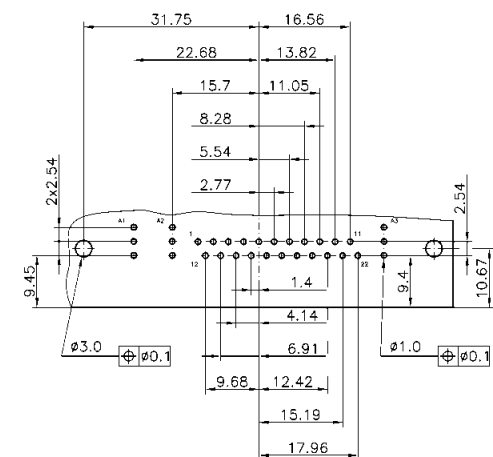
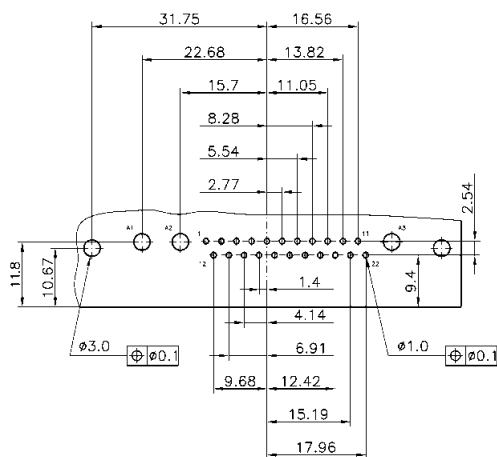

D-Sub

* When using a female connector with right angled pcb contacts the board drilling pattern must be mirrored in the Y axis.

Board drillings for connectors with right angled pcb contacts

Identification

Drawing

Dimensions in mm

Male connector*

27W2

Power contact

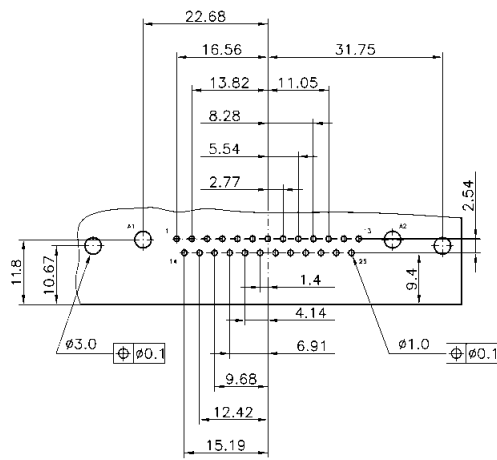

Coaxial contact

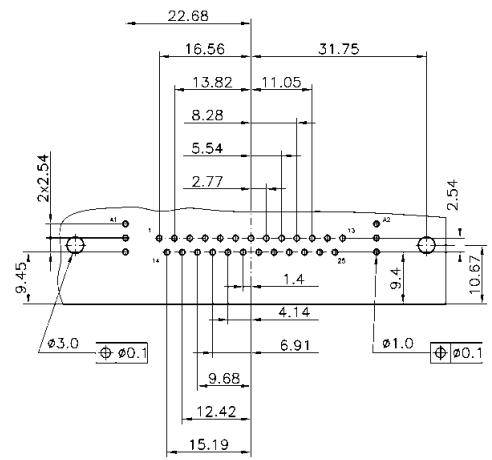

36W4

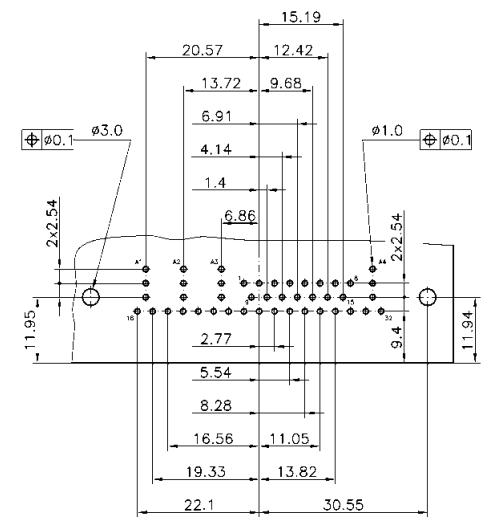
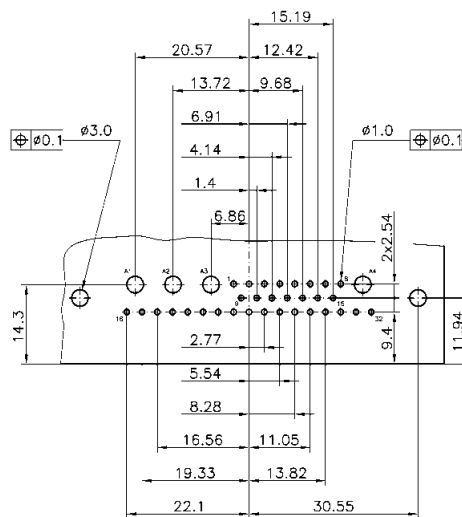

43W2

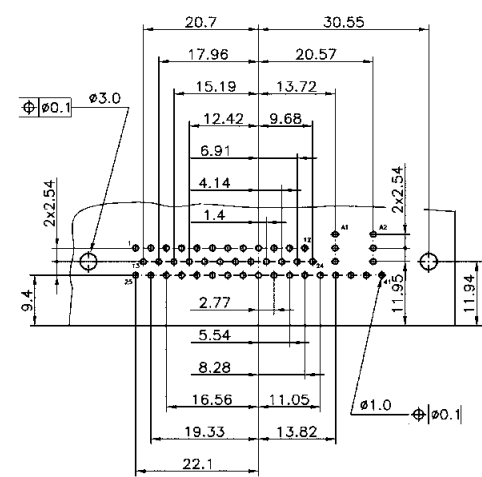
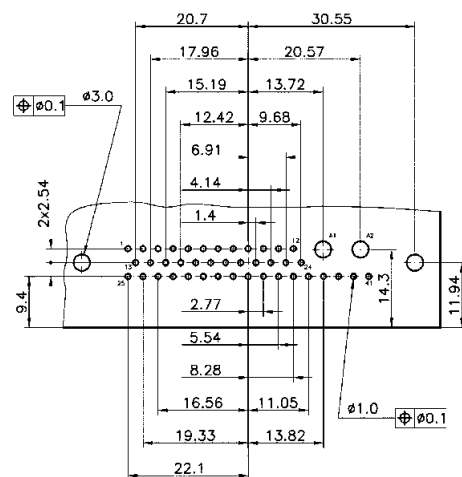

D-Sub

* When using a female connector with right angled pcb contacts the board drilling pattern must be mirrored in the Y axis.

HARTING customer request form for pcb connectors

1 Connector gender and type

- Plug (male contacts)
 Receptacle (female contacts)

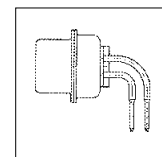
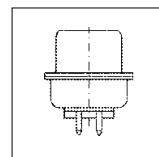

- Straight Right angled

2 Contact arrangement

Standard

- | | | | |
|------------------------------|-------------------------------|--------------------------------|-------------------------------|
| <input type="checkbox"/> 2W2 | <input type="checkbox"/> 7W7 | <input type="checkbox"/> 13W6 | <input type="checkbox"/> 25W3 |
| <input type="checkbox"/> 3W3 | <input type="checkbox"/> 8W8 | <input type="checkbox"/> 17W2 | <input type="checkbox"/> 27W2 |
| <input type="checkbox"/> 5W1 | <input type="checkbox"/> 9W4 | <input type="checkbox"/> 21W1 | <input type="checkbox"/> 36W4 |
| <input type="checkbox"/> 5W5 | <input type="checkbox"/> 11W1 | <input type="checkbox"/> 21WA4 | <input type="checkbox"/> 43W2 |
| <input type="checkbox"/> 7W2 | <input type="checkbox"/> 13W3 | <input type="checkbox"/> 24W7 | |

Special configurations
(mixed contact genders)

- 2W2C 3W3C

2.1 Any signal contacts?

- Yes (fill in questions below) No (go directly to item 2.2)
 Right angled 2.54 mm pitch
 Other pitch: _____

2.2 Any power contacts?

- Yes (fill in questions below) No (go directly to item 2.3)

Current rating

- 10 A 30 A
 20 A 40 A

Termination type

- Solder pin for pcb
 Press-in for pcb (30 A, straight version only)

Performance level

[mating side / termination side]

- S4 [0.76 µm Au / 0.2 µm Au]
 PL 3 [0.2 µm Au / 5.0 µm Sn]

2.3 Any coaxial contacts?

- Yes (fill in questions below) No (go directly to item 2.4)

Impedance

- 50 Ω
 75 Ω

Performance level

[mating side inner / outer conductor]

- S4 [1.3 µm Au / 0.76 µm Au]
 PL 3 [0.2 µm Au / 0.2 µm Au]

2.4 Any high voltage contacts?

- Yes No (go directly to item 2.5)

2.5 Any pneumatic contacts?

- Yes (fill in questions below) No (go directly to item 3)

Tube inner diameter /
suitable compressed air tube

- 2 mm / PU-2 2.6 mm / PU-N4* 2.5
 3 mm / PU-3 4 mm / PU-4

HARTING customer request form for pcb connectors

3 Pcb mounting accessories (select appropriate fixing accessories)

3.1 Right angled version

- Through hole
 - Nut 4-40 UNC
 - Nut M3
 - Metal bracket
 - Snap clip
 - Screw lock
 - fixed removable
 - 4-40 UNC M3
-

3.2 Straight version

- Through hole
 - Nut 4-40 UNC
 - Nut M3
 - Spacer 4-40 UNC
 - Spacer M3
 - Screw lock 4-40 UNC
 - Spacer 4-40 UNC + clip
 - Spacer M3 + clip
 - Spacer + clip and screw lock
 - M3 4-40 UNC
-

4 Additional information

- Pcb thickness: *(if possible provide pcb layout with plating specifications)*
- Operating temperature: standard SMC compatible
- Is hot plugging required? No Yes Short description: _____
- Is blind mating feature required? No Yes (provide precise requirements)

Name: _____ Drawing: no yes

Company: _____ Samples: no yes, quantity

Address: _____ Volume (pcs./year): _____

Phone: _____ Special requirements: _____

Fax: _____

E-Mail: _____

Interference – Yesterdays problem!

In a fast developing technological environment the management of electromagnetic interference is becoming more challenging.

Therefore HARTING developed a range of filter solutions to help designers of electronic equipments to achieve the demanding goal of electromagnetic compatibility.

HARTING offers a wide range of solutions by the integration of a filter inside one of the most standard I/O ports on the market; the D-Sub.

From standard simple ferrite-filter solution to complex customized high performance filters, you will be able to find in the HARTING filter D-Sub range the adequate solution to protect your application from any introduction or radiation of noise through D-Sub port apertures.

Advantages

Wide range:

- 9, 15, 25 and 37 contact versions
- Various terminations such as solder buckets, straight and right angled solder pins
- A large range of accessories
- High performance (C-filter) as well as simple, quick and cost effective solutions (ferrite-filter)

Compatible with standard wave and lead-free reflow soldering (C-filter)

Same layout and shell dimensions as standard D-Sub connectors, no modification of PCB design necessary

Elimination of ringing, crosstalk phenomenon thanks to specific multilayer PCB used in C-filter design.

Flexible filter structure allowing a wide range of customization:

- Filter value (even pin by pin approach)
- Pi-filter
- Dielectric withstanding and working voltage
- Specific ESD / lightning protection

HARTINGs broad Filter range

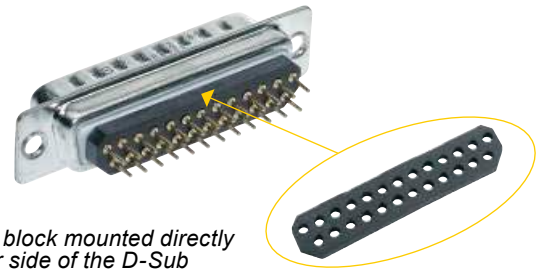

Ferrite block mounted directly on rear side of the D-Sub

Ferrite-filter

Ferrite-filter D-Subs providing a low level of filtering thanks to simple blocks of inductive ferrite attached to the back end of the connectors. Providing a few dB attenuation only at high frequencies HARTING ferrite-filter D-Subs represent a cost effective solution in applications where the emission level is close to the limit.

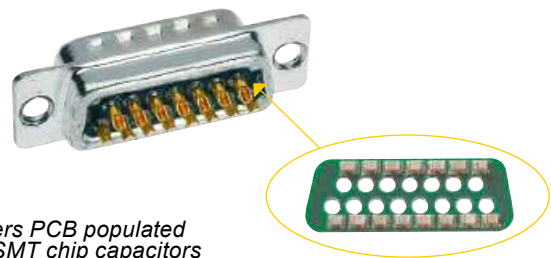

4 layers PCB populated with SMT chip capacitors

C-filter

To address higher EMI disturbances HARTING propose a comprehensive range of C-filter D-Sub connectors. HARTING C-filter D-Sub integrates a patented 4 layer printed circuit board equipped with chip capacitors. This patented solution provides complete protection of the I/O port due to the filtering performance of the capacitors and the screening effect of the PCB. Further more the 4 layers PCB also limits the ability of interference to enter the equipment through the D-Sub aperture. Available in 4 standard filter values 47, 470, 1000 and 3900 pF HARTING C-filter D-Subs represent for all designers a smart filtering solution allowing replacement of a “defective” port by a filtered one without any change of the PCB design.

Filter adapter

To support engineers in the diagnosis of EMI disturbances HARTING has developed, in addition to its filter series a range of male/female filter D-Sub adapters.

These back-to-back adapters can be used as testing tools and replaced later on in production directly by a filtered D-Sub connector.

Number of contacts 9, 15, 25, 37

Working current 7.5 A max.

Working voltage 250 V AC max.

Dielectric withstanding voltage 500 V AC for 1 minute

Contact resistance $\leq 15 \text{ m}\Omega$
 Insulation resistance $\geq 1000 \text{ M}\Omega$

Temperature range $-55 \text{ }^\circ\text{C} \dots +105 \text{ }^\circ\text{C}$

Terminations
 a) Solder buckets AWG 20
 b) Solder pins for P.C.B. holes $\text{Ø } 1 \pm 0.05 \text{ mm}$
 c) Solder pins, angled 90° for P.C.B. holes $\text{Ø } 1 \pm 0.05 \text{ mm}$

Materials
 Insulation PBT, flame retardant acc. to UL 94-V0

Contacts Copper alloy

Contact surface Performance level 3, as per IEC 60807-2, IEC 60512-25-2

Metal shell Steel (tin-plated)

Contact arrangement
 View from termination side

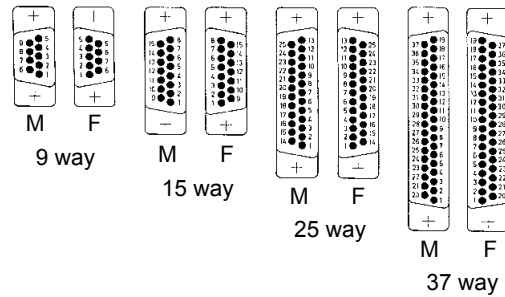

M = Male connector
 F = Female connector

Mating conditions as per CECC 75301

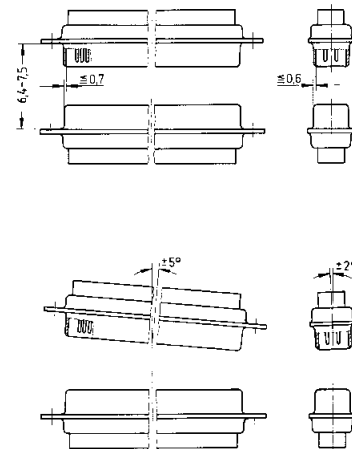

Minimum insertion loss

Frequency [MHz]	Attenuation [dB]
1	0.5
10	1.0
50	2.5
100	3.0
500	3.5
1000	4.0

D-Sub

Number of contacts

9-25



Solder pins, straight, through hole

Identification	No. of contacts	Part number	
		male connectors	female connectors
Connectors with ferrite-filter	9	09 64 122 7800	09 64 112 7800
	15	09 64 222 7800	09 64 212 7800
	25	09 64 322 7800	09 64 312 7800

Male connector

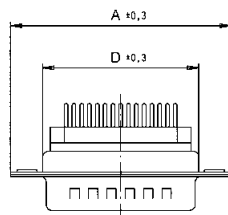
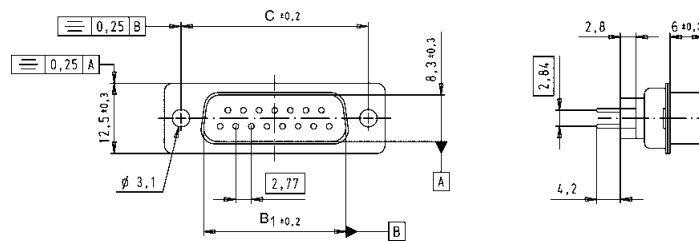

No. of contacts	A	B ₁	B ₂	C	D
9	30.8	16.92	16.3	25.0	19.2
15	39.2	25.25	24.6	33.3	27.7
25	53.1	38.96	38.3	47.1	41.1

Female connector

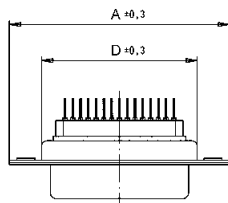
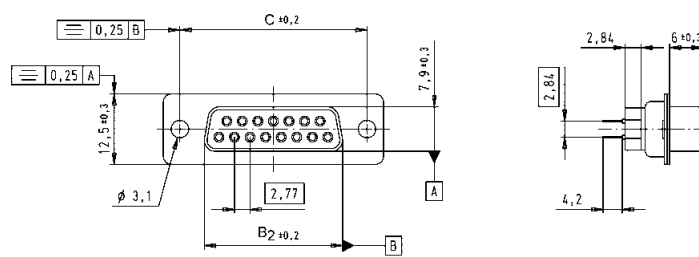

Board drillings

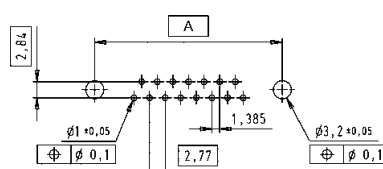

Dimensions in mm

Number of contacts

9-37



Solder pins, right angled, board lock and clinch nut

Identification	No. of contacts	Part number	
		male connectors	female connectors
Connectors with ferrite-filter	9	09 64 123 7802	09 64 113 7802
	15	09 64 223 7802	09 64 213 7802
	25	09 64 323 7802	09 64 313 7802
	37	09 64 423 7802	09 64 413 7802

Male connector

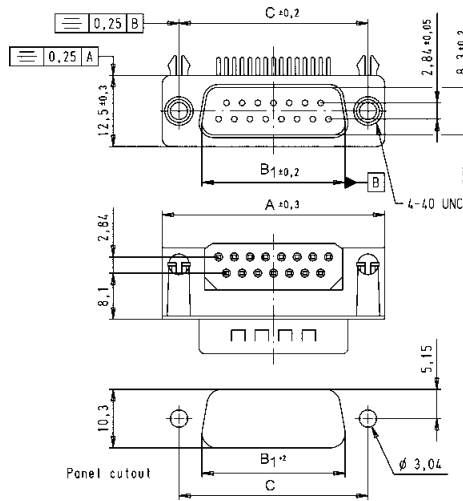

No. of contacts	A	B ₁	B ₂	C	E	F
9	30.8	16.92	16.3	25.0	3	4
15	39.2	25.25	24.6	33.3	6	7
25	53.1	38.96	38.3	47.1	11	12
37	69.4	55.42	54.8	63.5	17	18

Female connector

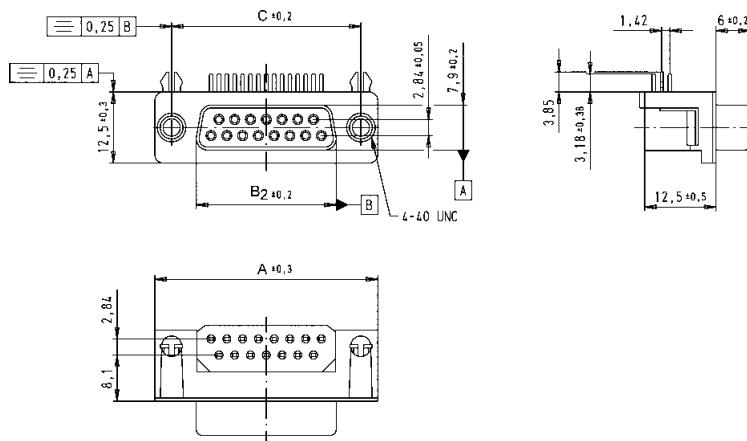

Board drillings

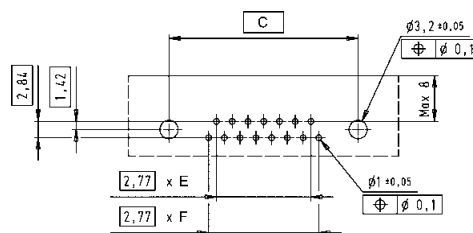

Dimensions in mm

D-Sub

Number of contacts

9-37



Solder buckets, through hole

Identification	No. of contacts	Part number	
		male connectors	female connectors
Connectors with ferrite-filter	9	09 64 121 7800	09 64 111 7800
	15	09 64 221 7800	09 64 211 7800
	25	09 64 321 7800	09 64 311 7800
	37	09 64 421 7800	09 64 411 7800

Male connector

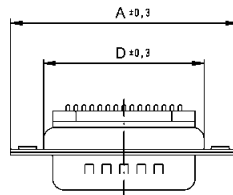
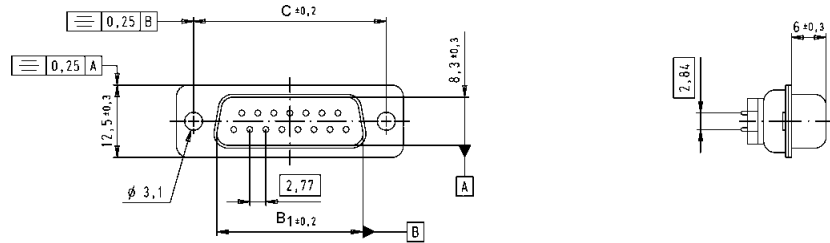

No. of contacts	A	B ₁	B ₂	C	D
9	30.8	16.92	16.3	25.0	19.2
15	39.2	25.25	24.6	33.3	27.7
25	53.1	38.96	38.3	47.1	41.1
37	69.4	55.42	54.8	63.5	57.3

Female connector

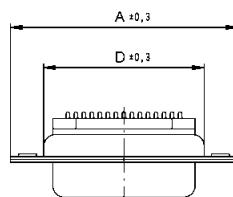
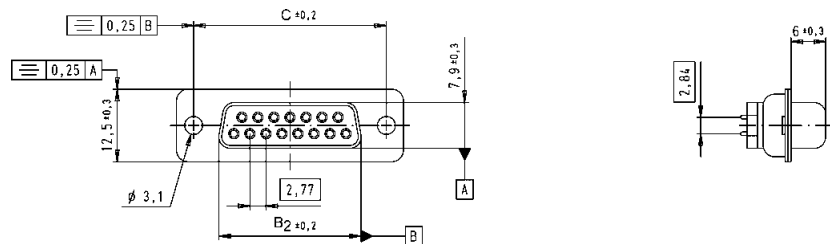

Number of contacts	9, 15, 25, 37
Working current	7.5 A max. (connectors) 6.5 A max. (filter adapters)
Working voltage	100 V max. for standard capacitance values – higher working voltages are available as specific.
Dielectric withstanding voltage	250 V DC max. – higher dielectric withstanding voltages are available as specific (see page 05.112)
Contact resistance	≤ 10 mΩ
Insulation resistance	≥ 1000 MΩ
Temperature range	-55 °C ... +125 °C (connectors) Heat deflection temperature limit according to DIN 53461: ... +255 °C -20 °C ... +125 °C (filter adapters)
Terminations	a) Solder buckets max. 0.8 mm ² b) Solder pins Ø 0.6 mm for P.C.B. holes Ø 0.8/1 mm c) Solder pins, angled 90° Ø 0.6 mm for P.C.B. holes Ø 0.8/1 mm
Materials	Insulation: PCT, glass-fibre filled, flame retardant acc. to UL 94-V0 Colour: natural Contacts: Copper alloy Male and female contacts are turned
Contact surface	Contact zone: Selectively plated according to performance level
Performance level	Performance level 2, as per CECC 75 301-802, 250 mating cycles, 4 days 4 mixed gas test – IEC 60512
Metal shell	Steel

Contact arrangement
View from termination side

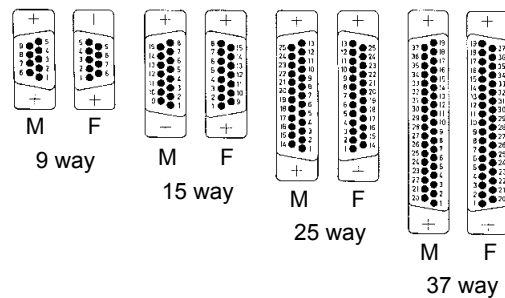

M = Male connector
F = Female connector

Mating conditions as per CECC 75 301

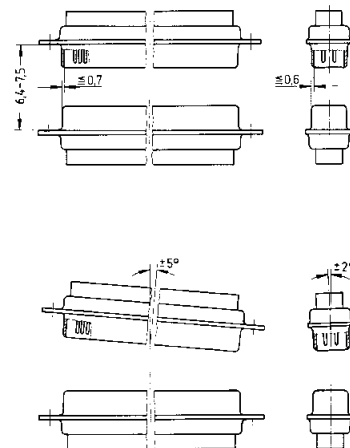

Attenuation characteristics for standard capacitance values

Min. insertion loss

Capacitance [pF] ¹⁾	Frequency [MHz]	Attenuation (in dB) vs. frequency [MHz]						
		1	5	10	50	100	500	1000
47							30	35
470				1	11	16	35	32
1000			1	3	12	24	38	30
3900		1	6	11	25	35	38	32

¹⁾ Capacitance tolerance = ± 20 % (For other capacitor values see pages 05.112 ff).

Measured in 50 Ω system according to MIL-STD-220, no load.

Working voltage: 100 V max. for standard capacitance values – higher working voltages are available as specific.

Dielectric withstanding voltage: 250 V DC max. – higher dielectric withstanding voltages are available as specific (see page 05.112)

Typical insertion loss for different filters (measured)

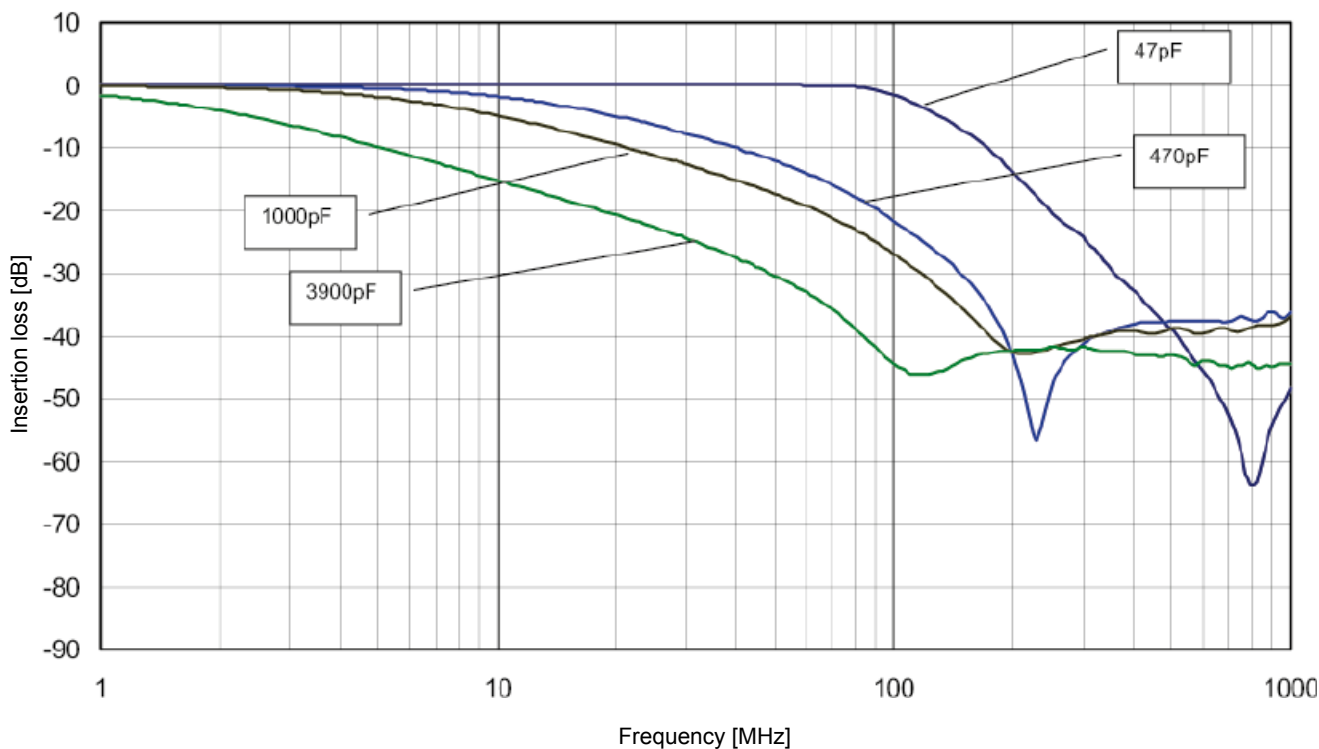

Number of contacts

9-37



Filter adapters

Identification	No. of contacts	Part number
Male / female filter adapters with C filter	9	09 64 100 72 ...
	15	09 64 200 72 ...
	25	09 64 300 72 ...
	37	09 64 400 72 ...
Please insert digit for capacitance <ul style="list-style-type: none"> 47 pF ▶ 10 470 pF ▶ 20 1000 pF ▶ 30 3900 pF ▶ 40 		

Dimensions

	A	B
9	32.8	24.99
15	41.1	33.32
25	55.0	47.04
37	71.3	63.50

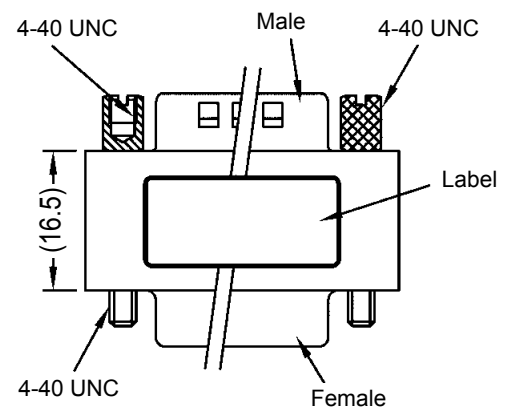
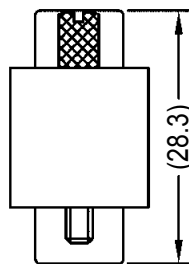
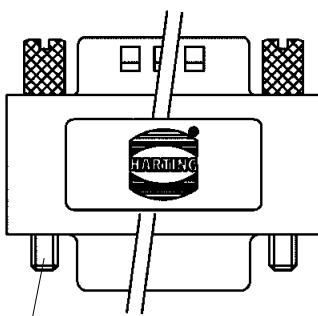
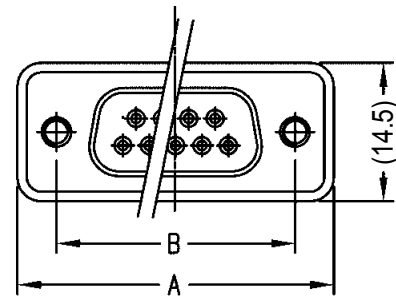

Screws are not pre-mounted to allow mounting from any ends

Number of contacts

9-37



Turned solder pins, straight, through hole

Identification	No. of contacts	Part number	
		male connectors	female connectors
Connectors with 47 pF C filter	9	09 64 122 7210	09 64 112 7210
	15	09 64 222 7210	09 64 212 7210
	25	09 64 322 7210	09 64 312 7210
	37	09 64 422 7210	09 64 412 7210
Connectors with 470 pF C filter	9	09 64 122 7220	09 64 112 7220
	15	09 64 222 7220	09 64 212 7220
	25	09 64 322 7220	09 64 312 7220
	37	09 64 422 7220	09 64 412 7220
Connectors with 1000 pF C filter	9	09 64 122 7230	09 64 112 7230
	15	09 64 222 7230	09 64 212 7230
	25	09 64 322 7230	09 64 312 7230
	37	09 64 422 7230	09 64 412 7230
Connectors with 3900 pF C filter	9	09 64 122 7240	09 64 112 7240
	15	09 64 222 7240	09 64 212 7240
	25	09 64 322 7240	09 64 312 7240
	37	09 64 422 7240	09 64 412 7240

D-Sub

Number of contacts

9-37



Turned solder pins, straight, through hole

Identification

Drawing

Dimensions in mm

Male connector

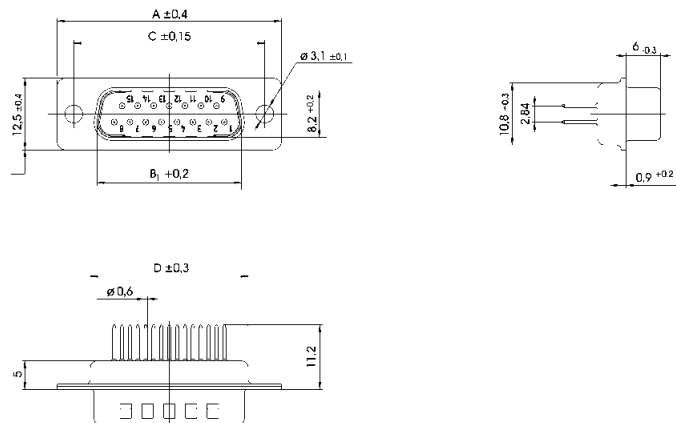

No. of contacts	A	B ₁	B ₂	C	D	E	F	G
9	30.8	16.9	16.4	25.00	19.3	1.37	2.74	12.50
15	39.1	25.2	24.7	33.30	27.5	1.37	2.74	16.65
25	53.0	38.9	38.5	47.04	41.3	1.40	2.77	23.52
37	69.3	55.3	54.9	63.50	57.7	1.40	2.77	31.75

Female connector

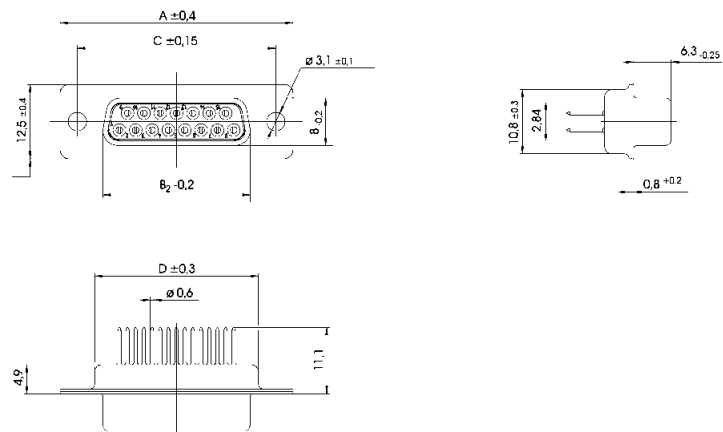

Board drillings

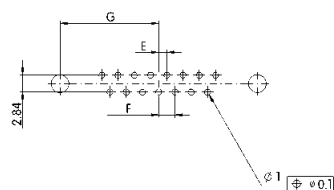

Number of contacts

9-37



Turned solder pins, straight, straight board clips

Identification	No. of contacts	Part number	
		male connectors	female connectors
Connectors with 47 pF C filter	9	09 64 122 721 .	09 64 112 721 .
	15	09 64 222 721 .	09 64 212 721 .
	25	09 64 322 721 .	09 64 312 721 .
	37	09 64 422 721 .	09 64 412 721 .
Connectors with 470 pF C filter	9	09 64 122 722 .	09 64 112 722 .
	15	09 64 222 722 .	09 64 212 722 .
	25	09 64 322 722 .	09 64 312 722 .
	37	09 64 422 722 .	09 64 412 722 .
Connectors with 1000 pF C filter	9	09 64 122 723 .	09 64 112 723 .
	15	09 64 222 723 .	09 64 212 723 .
	25	09 64 322 723 .	09 64 312 723 .
	37	09 64 422 723 .	09 64 412 723 .
Connectors with 3900 pF C filter	9	09 64 122 724 .	09 64 112 724 .
	15	09 64 222 724 .	09 64 212 724 .
	25	09 64 322 724 .	09 64 312 724 .
	37	09 64 422 724 .	09 64 412 724 .
Please insert digit for flange thread	4-40 UNC ▶	5	
	M3 ▶	6	

D-Sub

Number of contacts

9-37



Turned solder pins, straight, straight board clips

Identification

Drawing

Dimensions in mm

Male connector

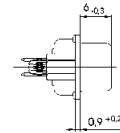
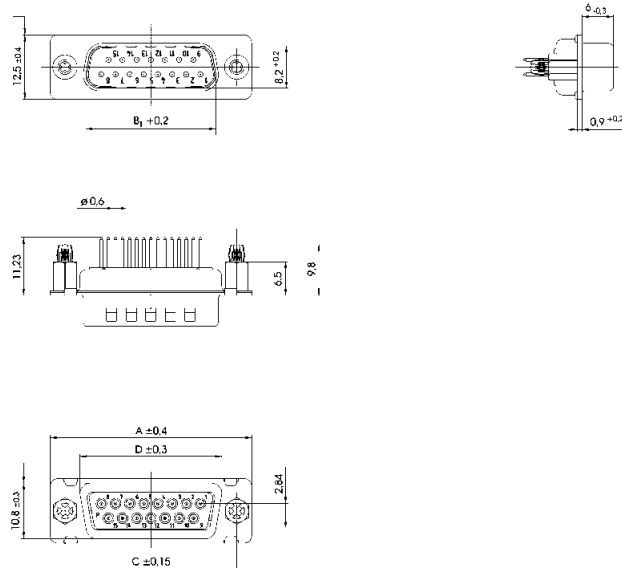

Female connector

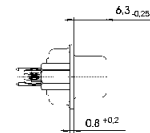
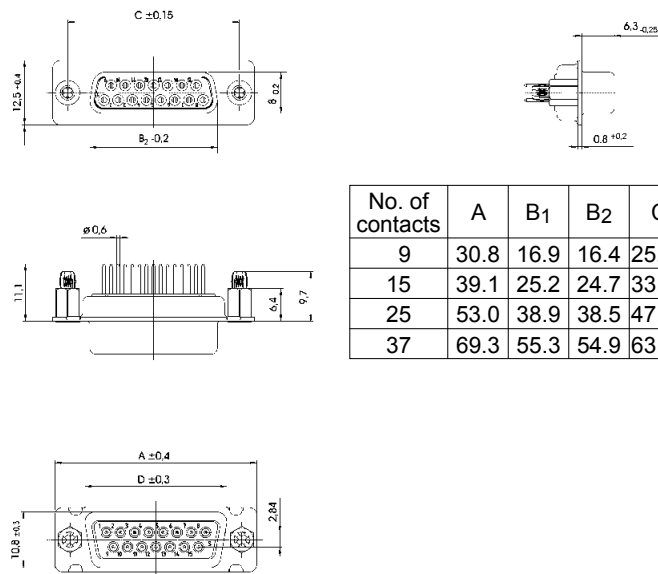

No. of contacts	A	B1	B2	C	D	E	F	G
9	30.8	16.9	16.4	25.00	19.3	1.37	2.74	12.50
15	39.1	25.2	24.7	33.30	27.5	1.37	2.74	16.65
25	53.0	38.9	38.5	47.04	41.3	1.40	2.77	23.52
37	69.3	55.3	54.9	63.50	57.7	1.40	2.77	31.75

Board drillings

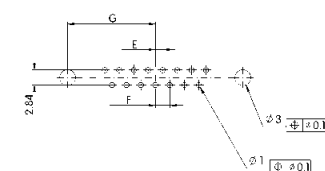

Number of contacts

9-37



Turned solder pins, right angled, bracket, board lock and clinch nut

Identification	No. of contacts	Part number	
		male connectors	female connectors
Connectors with 47 pF C filter	9	09 64 124 721 .	09 64 114 721 .
	15	09 64 224 721 .	09 64 214 721 .
	25	09 64 324 721 .	09 64 314 721 .
	37	09 64 424 721 .	09 64 414 721 .
Connectors with 470 pF C filter	9	09 64 124 722 .	09 64 114 722 .
	15	09 64 224 722 .	09 64 214 722 .
	25	09 64 324 722 .	09 64 314 722 .
	37	09 64 424 722 .	09 64 414 722 .
Connectors with 1000 pF C filter	9	09 64 124 723 .	09 64 114 723 .
	15	09 64 224 723 .	09 64 214 723 .
	25	09 64 324 723 .	09 64 314 723 .
	37	09 64 424 723 .	09 64 414 723 .
Connectors with 3900 pF C filter	9	09 64 124 724 .	09 64 114 724 .
	15	09 64 224 724 .	09 64 214 724 .
	25	09 64 324 724 .	09 64 314 724 .
	37	09 64 424 724 .	09 64 414 724 .
Please insert digit for flange thread	4-40 UNC ▶	2	
	M3 ▶	3	

D-Sub

Number of contacts

9-37



Turned solder pins, right angled, bracket, board lock and clinch nut

Identification

Drawing

Dimensions in mm

Male connector

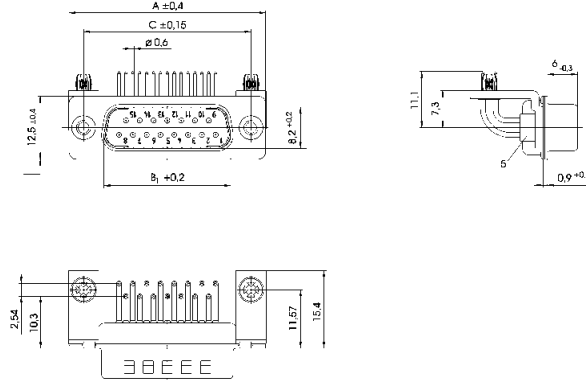

No. of contacts	A	B ₁	B ₂	C	E	F
9	30.8	16.9	16.4	25.00	1.37	2.74
15	39.1	25.2	24.7	33.30	1.37	2.74
25	53.0	38.9	38.5	47.04	1.40	2.77
37	69.3	55.3	54.9	63.50	1.40	2.77

Female connector

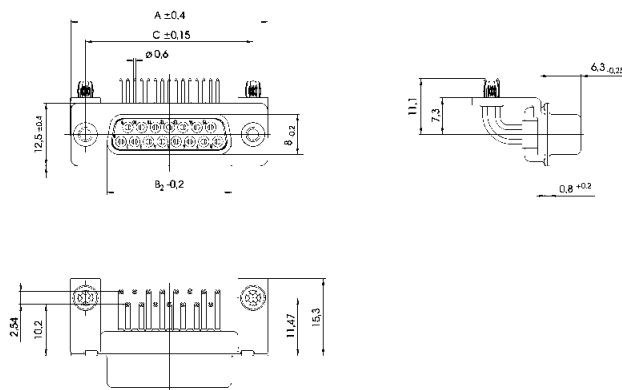

Board drillings

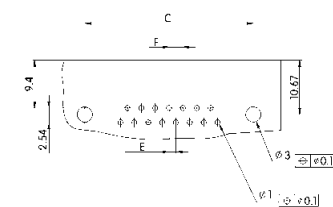

Number of contacts

9-37



Turned solder pins, right angled, bracket, board lock and female screw

Identification	No. of contacts	Part number	
		male connectors	female connectors
Connectors with 47 pF C filter	9	09 64 124 721 .	09 64 114 721 .
	15	09 64 224 721 .	09 64 214 721 .
	25	09 64 324 721 .	09 64 314 721 .
	37	09 64 424 721 .	09 64 414 721 .
Connectors with 470 pF C filter	9	09 64 124 722 .	09 64 114 722 .
	15	09 64 224 722 .	09 64 214 722 .
	25	09 64 324 722 .	09 64 314 722 .
	37	09 64 424 722 .	09 64 414 722 .
Connectors with 1000 pF C filter	9	09 64 124 723 .	09 64 114 723 .
	15	09 64 224 723 .	09 64 214 723 .
	25	09 64 324 723 .	09 64 314 723 .
	37	09 64 424 723 .	09 64 414 723 .
Connectors with 3900 pF C filter	9	09 64 124 724 .	09 64 114 724 .
	15	09 64 224 724 .	09 64 214 724 .
	25	09 64 324 724 .	09 64 314 724 .
	37	09 64 424 724 .	09 64 414 724 .
Please insert digit for flange thread	4-40 UNC ▶	4	
	M3 ▶	5	

D-Sub

Number of contacts

9-37



Turned solder pins, right angled, bracket, board lock and female screw

Identification

Drawing

Dimensions in mm

Male connector

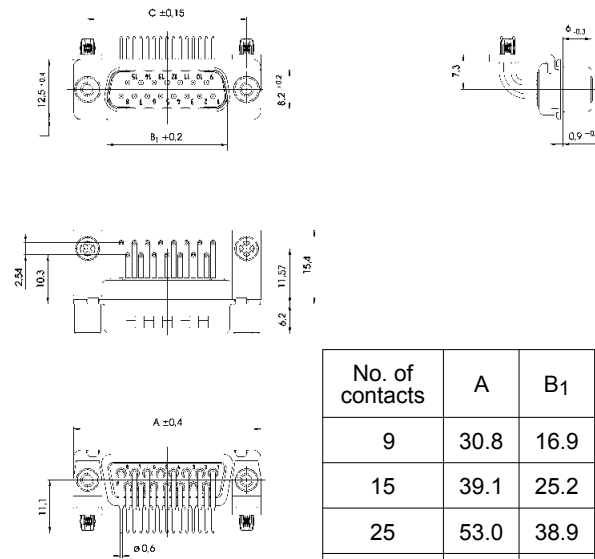

No. of contacts	A	B ₁	B ₂	C	E	F
9	30.8	16.9	16.4	25.00	1.37	2.74
15	39.1	25.2	24.7	33.30	1.37	2.74
25	53.0	38.9	38.5	47.04	1.40	2.77
37	69.3	55.3	54.9	63.50	1.40	2.77

Female connector

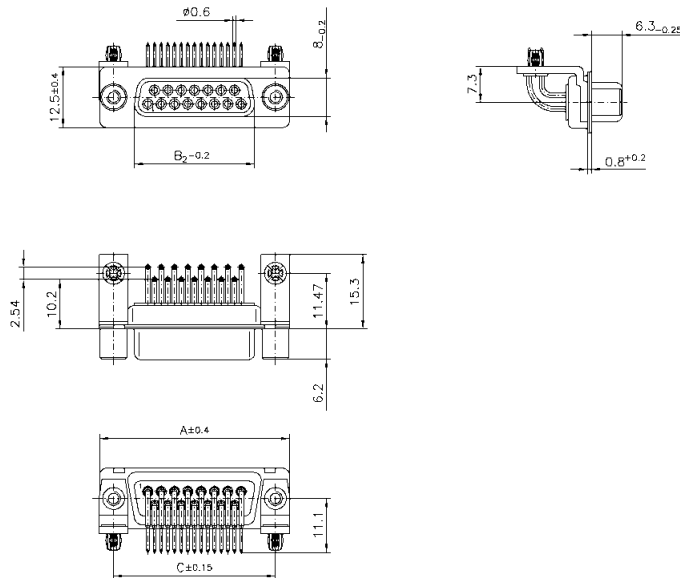

Board drillings

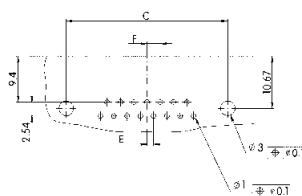

Number of contacts

9-37



Solder buckets, through hole

Identification	No. of contacts	Part number	
		male connectors	female connectors
Connectors with 47 pF C filter	9	09 64 121 7210	09 64 111 7210
	15	09 64 221 7210	09 64 211 7210
	25	09 64 321 7210	09 64 311 7210
	37	09 64 421 7210	09 64 411 7210
Connectors with 470 pF C filter	9	09 64 121 7220	09 64 111 7220
	15	09 64 221 7220	09 64 211 7220
	25	09 64 321 7220	09 64 311 7220
	37	09 64 421 7220	09 64 411 7220
Connectors with 1000 pF C filter	9	09 64 121 7230	09 64 111 7230
	15	09 64 221 7230	09 64 211 7230
	25	09 64 321 7230	09 64 311 7230
	37	09 64 421 7230	09 64 411 7230
Connectors with 3900 pF C filter	9	09 64 121 7240	09 64 111 7240
	15	09 64 221 7240	09 64 211 7240
	25	09 64 321 7240	09 64 311 7240
	37	09 64 421 7240	09 64 411 7240

D-Sub

Number of contacts

9-37



Solder buckets, through hole

Identification

Drawing

Dimensions in mm

Male connector

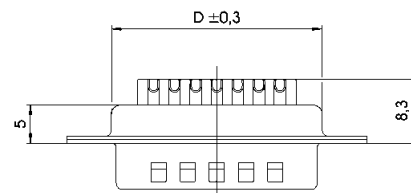
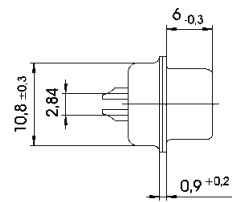
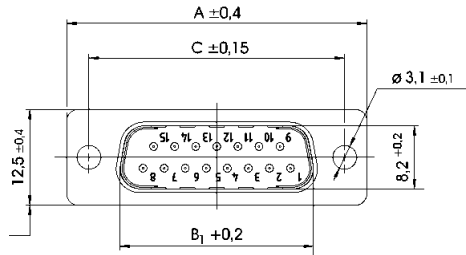

No. of contacts	A	B ₁	B ₂	C	D
9	30.8	16.9	16.4	25.00	19.3
15	39.1	25.2	24.7	33.30	27.5
25	53.0	38.9	38.5	47.04	41.3
37	69.3	55.3	54.9	63.50	57.7

Female connector

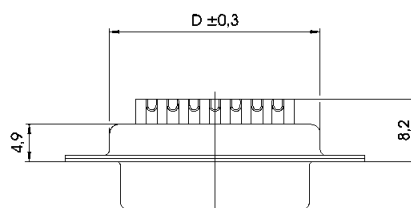
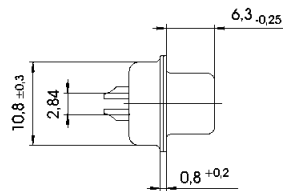
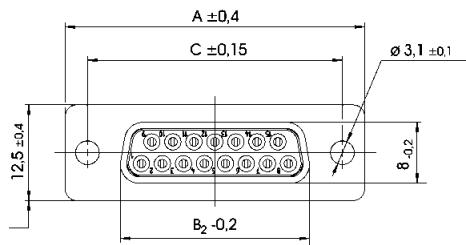

Number of contacts

9-37



Solder buckets, clinch nut

Identification	No. of contacts	Part number	
		male connectors	female connectors
Connectors with 47 pF C filter	9	09 64 121 721 .	09 64 111 721 .
	15	09 64 221 721 .	09 64 211 721 .
	25	09 64 321 721 .	09 64 311 721 .
	37	09 64 421 721 .	09 64 411 721 .
Connectors with 470 pF C filter	9	09 64 121 722 .	09 64 111 722 .
	15	09 64 221 722 .	09 64 211 722 .
	25	09 64 321 722 .	09 64 311 722 .
	37	09 64 421 722 .	09 64 411 722 .
Connectors with 1000 pF C filter	9	09 64 121 723 .	09 64 111 723 .
	15	09 64 221 723 .	09 64 211 723 .
	25	09 64 321 723 .	09 64 311 723 .
	37	09 64 421 723 .	09 64 411 723 .
Connectors with 3900 pF C filter	9	09 64 121 724 .	09 64 111 724 .
	15	09 64 221 724 .	09 64 211 724 .
	25	09 64 321 724 .	09 64 311 724 .
	37	09 64 421 724 .	09 64 411 724 .
Please insert digit for flange thread	4-40 UNC ▶	7	
	M3 ▶	8	

D-Sub

Number of contacts

9-37



Solder buckets, clinch nut

Identification

Drawing

Dimensions in mm

Male connector

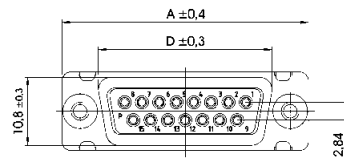
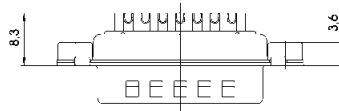
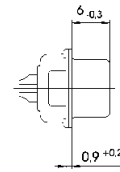
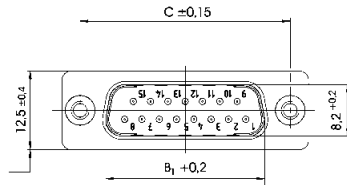

No. of contacts	A	B ₁	B ₂	C	D
9	30.8	16.9	16.4	25.00	19.3
15	39.1	25.2	24.7	33.30	27.5
25	53.0	38.9	38.5	47.04	41.3
37	69.3	55.3	54.9	63.50	57.7

Female connector

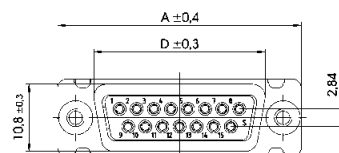
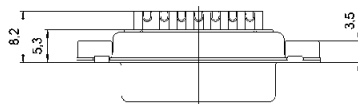
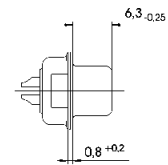
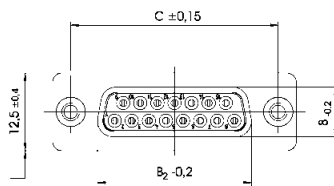

Panel cut outs / panel mountings

Panel cut outs

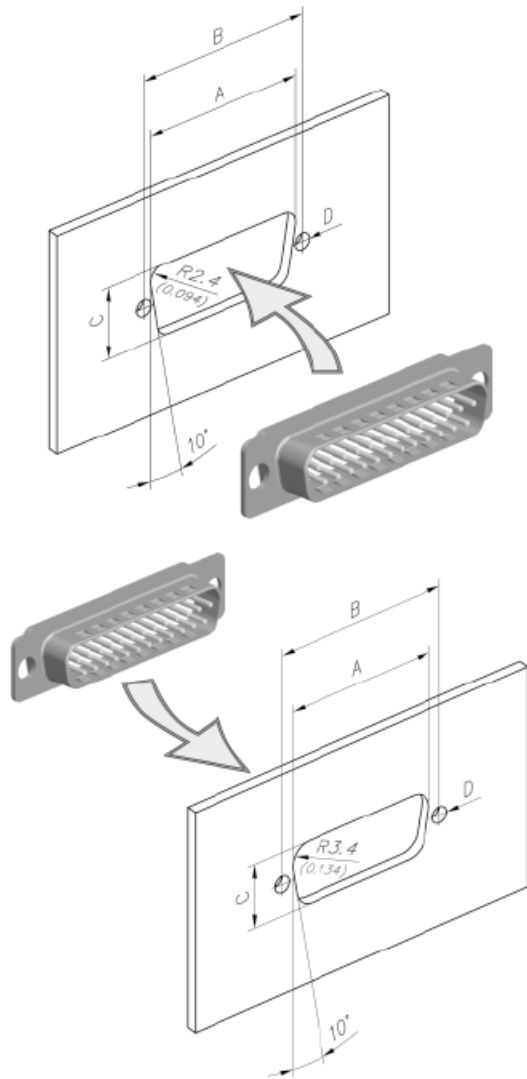

Front mounting

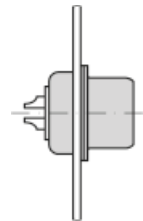

Rear mounting

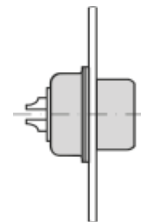

No. of contacts	Mounting assembly	A ± 0.2	B ± 0.2	C ± 0.2
9	Front	22.2	25.0	12.3
	Rear	20.5	25.0	11.4
15	Front	30.5	33.3	12.3
	Rear	28.8	33.3	11.4
25	Front	44.3	47.0	12.3
	Rear	42.5	47.0	11.4
37	Front	60.7	63.5	12.3
	Rear	59.1	63.5	11.4

Panel mountings

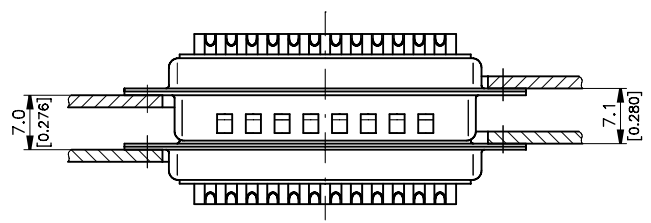
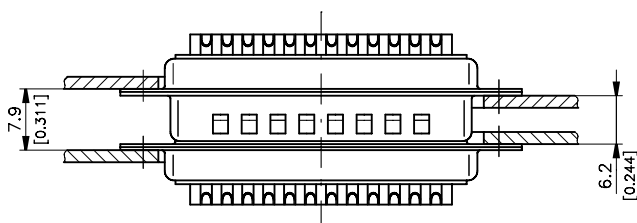

For float mounting option please contact your local HARTING representative.

Dimensions in mm

General information

With the innovative EMC platform approach, this enables customers to select their optimum filter requirements, contact per contact. Allowing not only to segregate the filtering per contact but also to mix the type of filter used. This is then cast in a single competitive product (in a standard D-Sub shell).

The biggest advantage of the HARTING technology is that multiple filter assemblies can be configured to create different filter designs: C, Pi, L and T types. Since any value of capacitor can be placed on any contact, a wide range of configurations can be built, it is even possible to have an individual pin unfiltered if necessary.

Furthermore, ***Pi filters can be supplied in a standard connector size shell.*** In addition, protection against lightening and transient voltage can be included upon request.

In the next few pages, you will find all the necessary information plus a selection guide to help you to choose your appropriate solution.



or

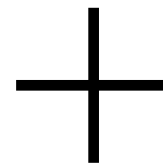

- C filter
- L filter
- Pi filter
- ESD protection
- Lightening protection
- Combination



With any capacitance on any pin in a **standard D-Sub shell.**

General information

Filter possibilities

C filter:

Non exhaustive list of C filter values that HARTING can supply (for specials see page 05.114 ff)

C filter capacitance in pF	Minimum insertion loss								Max. working voltage	Max. dielectric withstanding
	Attenuation [dB] vs frequency [MHz]									
	0.1	1	5	10	50	100	500	1000		
47						30	35	500 V DC	750 V DC	
100					1	3	40	35	500 V DC	750 V DC
150					1	6	45	35	500 V DC	750 V DC
180					1	10	40	32	500 V DC	750 V DC
270				1	3	12	35	32	500 V DC	750 V DC
330				1	7	13	35	32	500 V DC	750 V DC
470				1	10	15	35	32	500 V DC	750 V DC
820				2	10	18	30	30	500 V DC	750 V DC
1000			1	3	12	20	34	30	500 V DC	750 V DC
1800			2	6	17	30	35	32	500 V DC	750 V DC
3900		1	6	11	25	35	35	32	500 V DC	750 V DC
4700		1	9	13	30	38	35	32	500 V DC	750 V DC
5600		2	10	14	30	32	32	32	500 V DC	750 V DC
10000		1	10	15	30	32	30	30	200 V DC	500 V DC
33000	1	9	19	29	32	34	39	32	100 V DC	150 V DC
47000	1	11	23	30	32	32	35	32	100 V DC	150 V DC
100000	2	18	32	40	34	34	36	35	25 V DC	40 V DC

Pi filter:

Non exhaustive list of Pi filter values that HARTING can supply (for specials see page 05.114 ff)

Pi filter capacitance in pF	Minimum insertion loss								Max. working voltage	Max. dielectric withstanding
	Attenuation [dB] vs frequency [MHz]									
	0.1	1	5	10	50	100	500	1000		
94						2	35	50	200 V DC	500 V DC
200					1	8	50	40	200 V DC	500 V DC
440				1	8	16	50	40	200 V DC	500 V DC
940				2	12	24	50	40	200 V DC	500 V DC
2000			2	7	17	40	45	40	200 V DC	500 V DC
4400			5	10	28	60	45	40	200 V DC	500 V DC
9400		2	10	15	48	50	45	40	200 V DC	500 V DC
20000		5	14	20	50	60	52	48	100 V DC	250 V DC
94000	2	15	32	50	51	52	48	42	50 V DC	125 V DC
200000	7	21	48	65	55	52	48	42	16 V DC	25 V DC

General information

Other protection possibilities

ESD protection

(Electro Static Discharge protection)

For equipment to comply with:

- IEC-1000-4-2; levels 1 to 4 (Contact discharge test)
- RTCA-160 D; section 25

Typical parasitic capacitance (pF)	Max. clamp voltage (V)	Working voltage (V)
0.5 V _{rms} @ 1 KHz	@ I = 1 A @ 8/20 μS	@ I = 10 μA
1750	7.5	3
1250	13	5
650	22	12
430	33	18
220	48	26
200	51	30

EMP protection

(Electro Magnetic Pulse protection)

For equipment to comply with:

- MIL-STD-461 C: requirements CS 06, CS 10, CS 11, RS 05
- IEC-1000-4-4; EFT TESTS
- RTCA-160 D; section 17

Typical parasitic capacitance (pF)	Max. clamp voltage (V)	Working voltage (V)
0.5 V _{rms} @ 1 KHz	@ I = 10 A @ 8/20 μS	@ I = 10 μA
5675	9	3
3620	15	5
1500	26	14
820	34	18
275	50	26

Lightening protection

For equipment to comply with:

- IEC-1000-4-5; levels 1 and 2 (1.2 μ / 50 μS)
- RTCA-160 D; section 22 (pin injection, level 1)

Typical parasitic capacitance (pF)	Max. clamp voltage (V)	Working voltage (V)
0.5 V _{rms} @ 1 KHz	@ I = 30 A @ 8/20 μS	@ I = 10 μA
5500	12	3
3175	18	5
2000	21	9
1680	30	14
900	38	18
720	60	26
600	63	30

HARTING customer request form

Our innovative technology offers all the possibilities you may need.
 For customer solutions, please contact your local HARTING representative.
 Here is a summary of the information we need to develop a customer solution:

Connector

Standard D-Sub

Gender Male Female

No. of contacts 9 15 25 37 50

Termination Solder bucket Straight pcb

R/A Eur, 2.54 mm R/A US, 2.84 mm

Mixed D-Sub

Gender Male Female

Contact arrangement 3W3 3W3C Other _____

Power contact rating 10 A 20 A 30 A 40 A

Termination Solder bucket Straight pcb

R/A pcb (please specify the board drillings)

Flange thread and board locking options

Right angled version

Through hole

Clinch nut 4-40 UNC

Clinch nut M3

Bracket

Board lock

Female screw lock 4-40 UNC

Female screw lock M3

Straight version

Through hole

Clinch nut 4-40 UNC

Clinch nut M3

Spacer 4-40 UNC

Spacer M3

Female screw lock 4-40 UNC

Spacer 4-40 UNC + board lock

Spacer M3 + board lock

Spacer + board lock and female screw lock

M3 4-40 UNC

HARTING customer request from

Filter

What working voltage is used? _____

What is the maximum dielectric withstanding voltage needed? _____

Type of filter _____ (C filter, Pi filter*, L filter ...)

Capacitance _____

Are there other protections needed? No Yes

ESD Transient
 EMP Lightening

If a pin-to-pin selection has to be done, please state the details Pin 1: ?, Pin 2: ?, ...

Name: _____ Drawing: no yes

Company: _____ Samples: no yes, quantity

Address: _____ Volume (pcs./year): _____

Phone: _____ Special requirements: _____

Fax: _____

E-Mail: _____

Number of contacts	9, 15, 25, 37, 50 UL recognized
Working current	5 A
Test voltage	1200 V for 1 minute between 2 contacts / contact and shell
Clearance and creepage	≥ 1.0 mm
Contact resistance	Straight contact ≤ 10 mΩ Angled contact ≤ 25 mΩ Angled contact 50-pole ≤ 35 mΩ
Insulation resistance	between contacts ≥ 5000 MΩ
Dielectric strength	50 kV/mm
Temperature range	-25 °C ... +70 °C
Protection	IP67 (per DIN 40050 / IEC 529)
Termination	Solder cup max. AWG 20 Solder pin straight 0.6 mm diameter Solder pin angled 0.6 mm diameter
Material	Shell Brass, tin plated Insulator and plastic watertight frame Thermoplastic, glass-fibre filled, UL 94-V0 Metal watertight frame Nickel plated zinc die cast Contact material Machined copper alloy
Contact surface	Contact zone S4 = 0.76 μm (30 μinch) Au or PdNi equivalent
Waterproofing element	Silicone
Mechanical	Mating cycles ≥ 500 Mating force per signal contact ≤ 3.4 N Unmating force per signal contact ≥ 0.2 N

Contact arrangement View from termination side

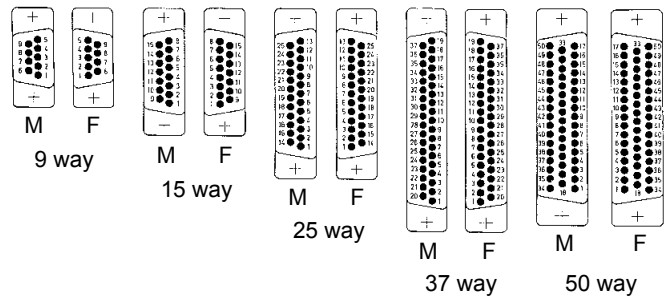

M = Male connector
F = Female connector

Mating conditions as per DIN 41 652

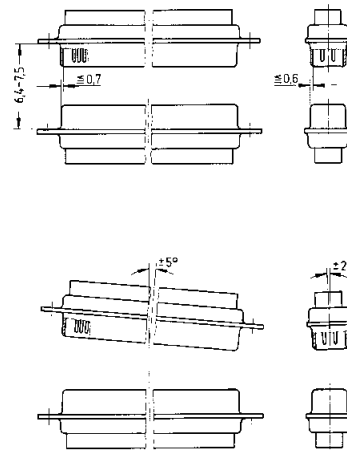

Number of contacts

9-50



IP67, turned solder cups

Identification	No. of contacts	Part number
		S4 ¹⁾
Male connector metal shell with dimples	9 15 25 37 50	09 67 409 5615 09 67 415 5615 09 67 425 5615 09 67 437 5615 09 67 450 5615
Female connector metal shell	9 15 25 37 50	09 67 409 4715 09 67 415 4715 09 67 425 4715 09 67 437 4715 09 67 450 4715

D-Sub

¹⁾ S4 = 0.76 µm (30 µinch) Au or PdNi equivalent

Number of contacts

9-50



IP67, turned solder cups

Identification

Drawing

Dimensions in mm

Male connector
9 – 50 contacts

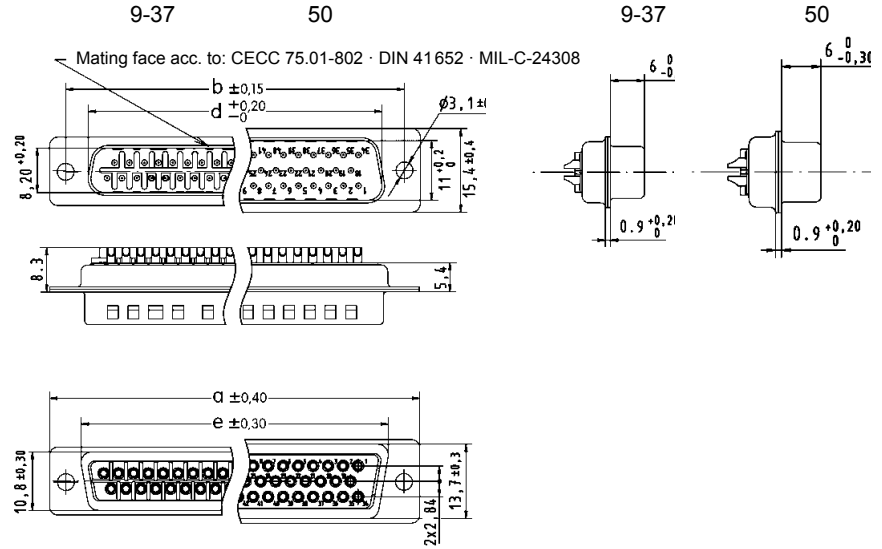

Female connector
9 – 50 contacts

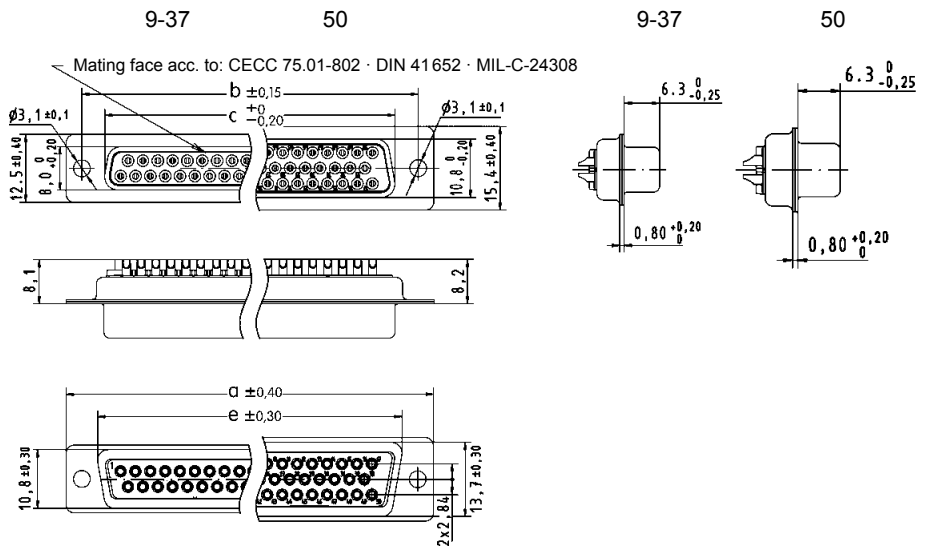

	a	b	c	d	e
9	30.8	25.00	16.4	16.9	19.3
15	39.1	33.30	24.7	25.2	27.5
25	53.0	47.04	38.5	38.9	41.3
37	69.3	63.50	54.9	55.3	57.7
50	66.9	61.10	52.5	52.8	55.3

Number of contacts

9-25



IP67, turned solder cups, with rear plastic mounting plate

Identification	No. of contacts	Part number
<p>Male connector metal shell with dimples</p> <p>Please insert digit for flange thread</p> <p>4-40 UNC ▶ 7 M3 ▶ 9</p>	<p>9 15 25</p>	<p>S4¹⁾</p> <p>09 67 509 . 615 09 67 515 . 615 09 67 525 . 615</p>
<p>Female connector metal shell</p> <p>Please insert digit for flange thread</p> <p>4-40 UNC ▶ 6 M3 ▶ 8</p>	<p>9 15 25</p>	<p>09 67 509 . 715 09 67 515 . 715 09 67 525 . 715</p>

¹⁾ S4 = 0.76 µm (30 µinch) Au or PdNi equivalent

Number of contacts

9-25



IP67, turned solder cups, with rear plastic mounting plate

Identification

Drawing

Dimensions in mm

Male connector
9 – 25 contacts

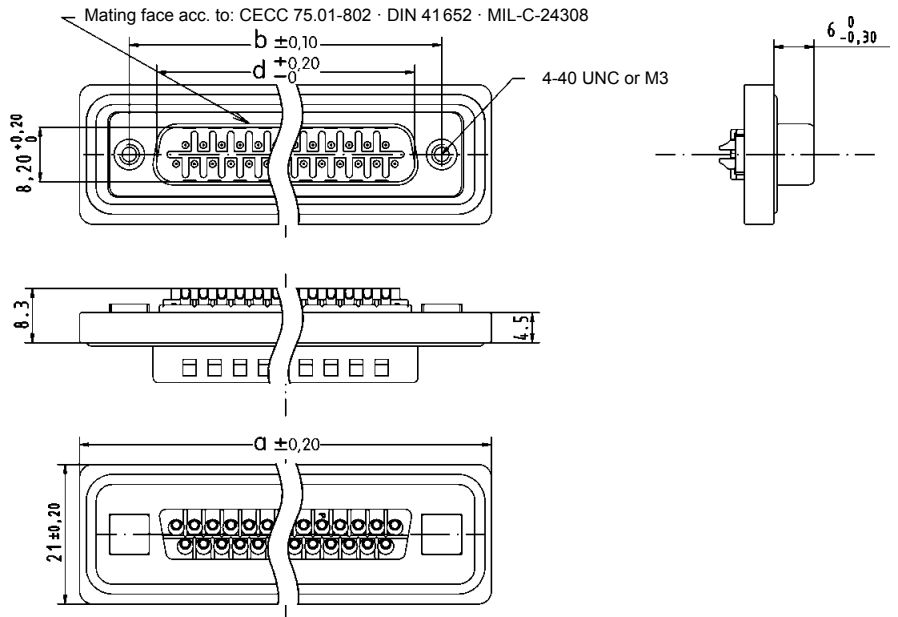

Female connector
9 – 25 contacts

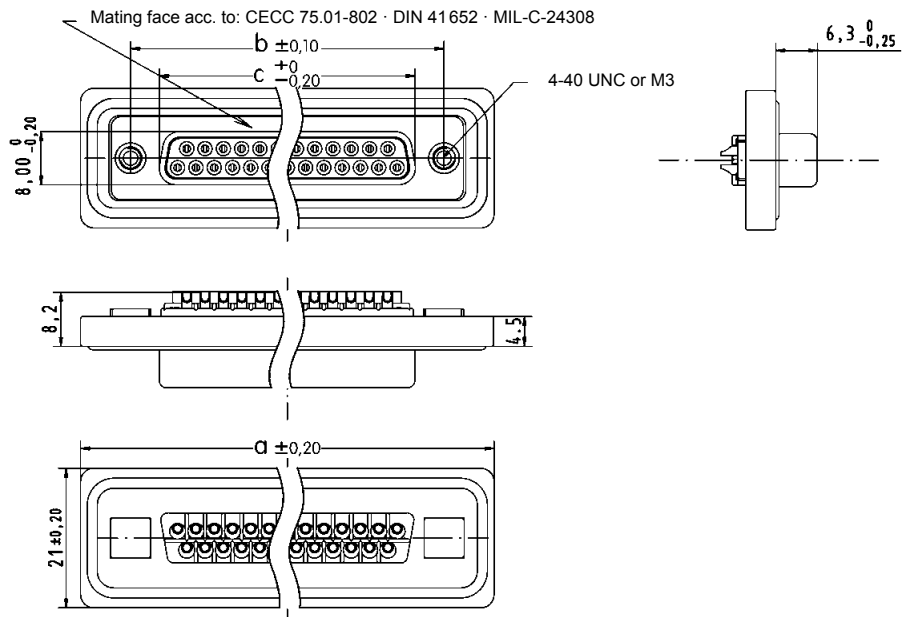

	a	b	c	d
9	40.0	25.00	16.4	16.9
15	48.3	33.30	24.7	25.2
25	62.0	47.04	38.5	38.9

Number of contacts

9-25

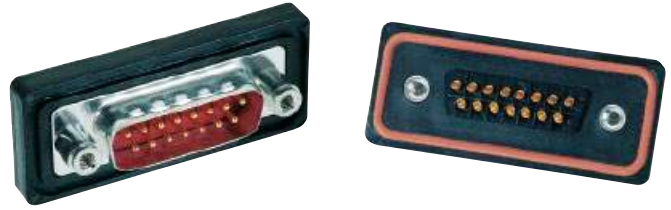

IP67, turned solder cups, with front plastic mounting plate

Identification	No. of contacts	Part number
<p>Male connector metal shell with dimples</p> <p>Please insert digit for flange thread</p> <p>4-40 UNC ▶ 7 M3 ▶ 9</p>	<p>9 15 25</p>	<p>S4¹⁾</p> <p>09 67 709 . 615 09 67 715 . 615 09 67 725 . 615</p>
<p>Female connector metal shell</p> <p>Please insert digit for flange thread</p> <p>4-40 UNC ▶ 6 M3 ▶ 8</p>	<p>9 15 25</p>	<p>09 67 709 . 715 09 67 715 . 715 09 67 725 . 715</p>

¹⁾ S4 = 0.76 µm (30 µinch) Au or PdNi equivalent

Number of contacts

9-25



IP67, turned solder cups, with front plastic mounting plate

Identification

Drawing

Dimensions in mm

Male connector
9 – 25 contacts

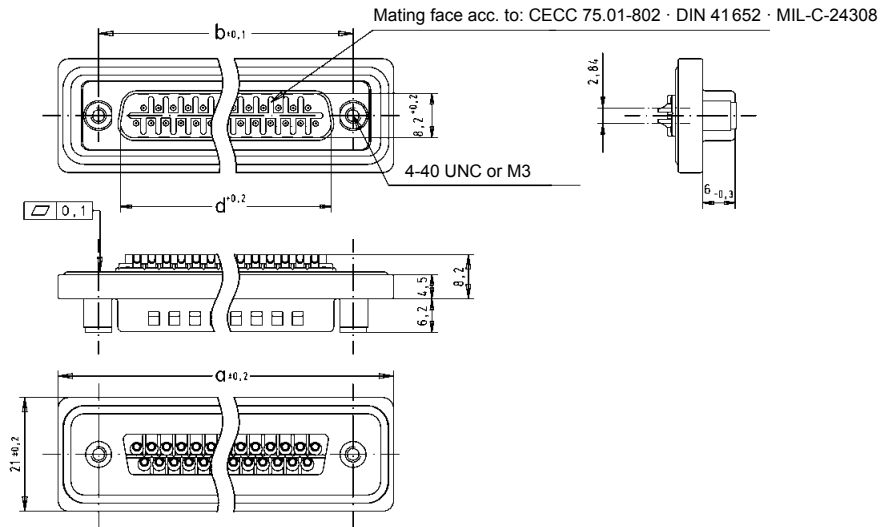

Female connector
9 – 25 contacts

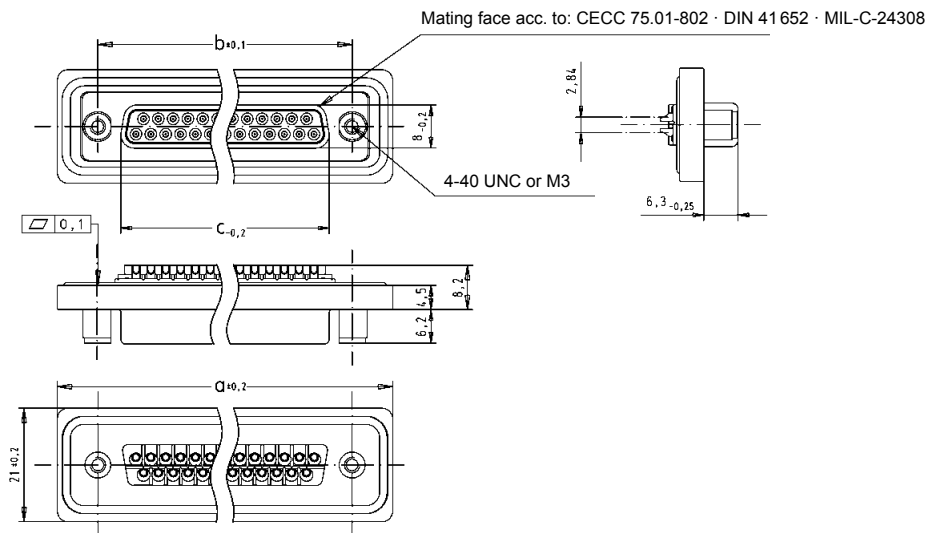

	a	b	c	d
9	40.0	25.00	16.4	16.9
15	48.3	33.30	24.7	25.2
25	62.0	47.04	38.5	38.9

Panel cut out
for front/rear mount

Values are taken from the
CECC 75301-802

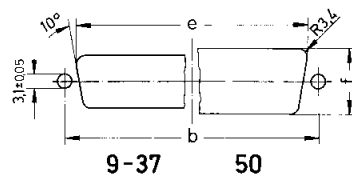

Front mount

	$b_{\pm 0.13}$	$e_{\pm 0.2}$	$f_{\pm 0.2}$
9	25.0	22.2	12.3
15	33.3	30.5	12.3
25	47.0	44.3	12.3

Rear mount

	$b_{\pm 0.13}$	$e_{\pm 0.2}$	$f_{\pm 0.2}$
9	25.0	20.5	11.4
15	33.3	28.8	11.4
25	47.0	42.5	11.4

Number of contacts

9–50



IP67, turned solder cups, with rear metal mounting plate

Identification	No. of contacts	Part number
S4 ¹⁾		
Male connector metal shell with dimples Please insert digit for flange thread 4-40 UNC ▶ 7 M3 ▶ 9	9 15 25 37 50	09 67 609 . 615 09 67 615 . 615 09 67 625 . 615 09 67 637 . 615 09 67 650 . 615
Female connector metal shell Please insert digit for flange thread 4-40 UNC ▶ 6 M3 ▶ 8	9 15 25 37 50	09 67 609 . 715 09 67 615 . 715 09 67 625 . 715 09 67 637 . 715 09 67 650 . 715

¹⁾ S4 = 0.76 µm (30 µinch) Au or PdNi equivalent

Number of contacts

9-50



IP67, turned solder cups, with rear metal mounting plate

Identification

Drawing

Dimensions in mm

Male connector
9 – 50 contacts

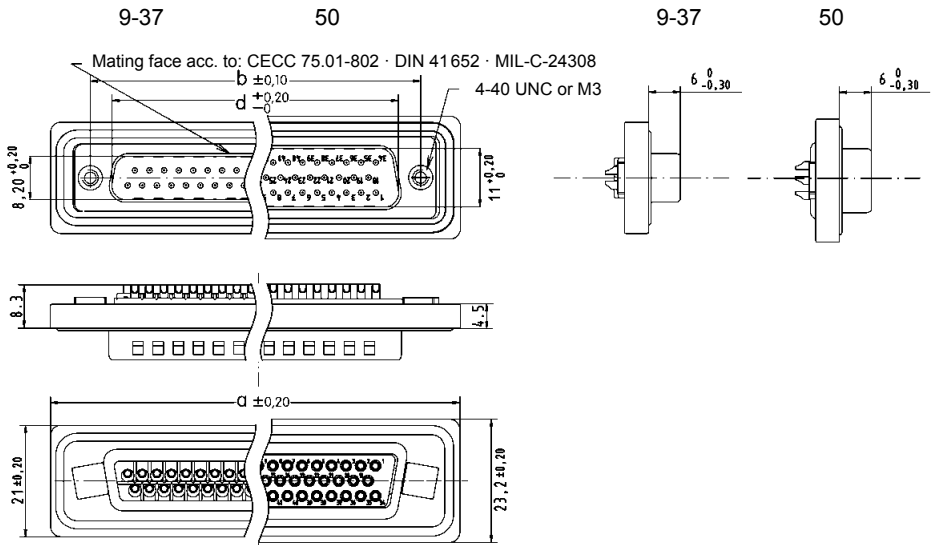

Female connector
9 – 50 contacts

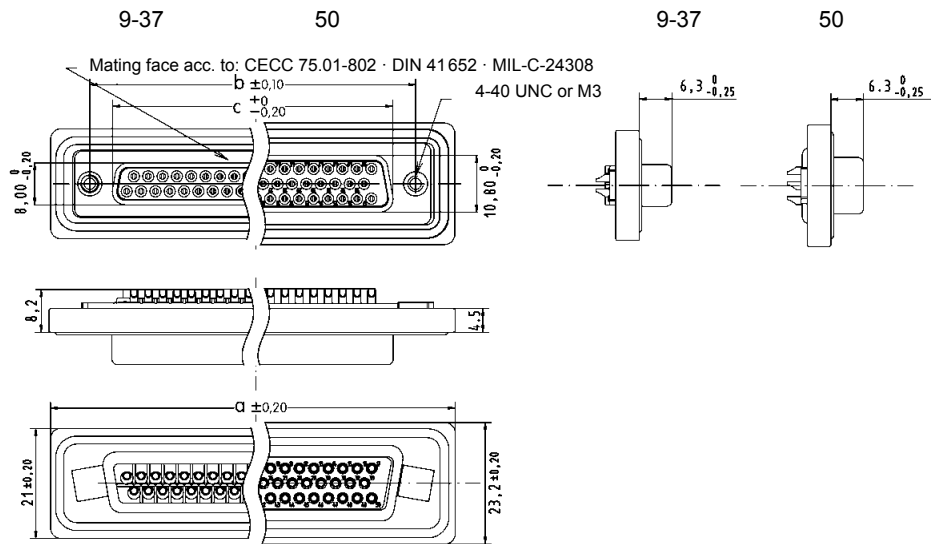

	a	b	c	d
9	40,0	25,00	16,4	16,9
15	48,3	33,30	24,7	25,2
25	62,0	47,04	38,5	38,9
37	78,5	63,50	54,9	55,3
50	76,1	61,10	52,5	52,8

Number of contacts

9-50



IP67, turned solder cups, with front metal mounting plate

Identification	No. of contacts	Part number
S4¹⁾		
<p>Male connector metal shell with dimples</p> <p>Please insert digit for flange thread</p> <p>4-40 UNC ▶ 7 M3 ▶ 9</p>	<p>9 15 25 37 50</p>	<p>09 67 809 . 615 09 67 815 . 615 09 67 825 . 615 09 67 837 . 615 09 67 850 . 615</p>
<p>Female connector metal shell</p> <p>Please insert digit for flange thread</p> <p>4-40 UNC ▶ 6 M3 ▶ 8</p>	<p>9 15 25 37 50</p>	<p>09 67 809 . 715 09 67 815 . 715 09 67 825 . 715 09 67 837 . 715 09 67 850 . 715</p>

¹⁾ S4 = 0.76 µm (30 µinch) Au or PdNi equivalent

Number of contacts

9-50



IP67, turned solder cups, with front metal mounting plate

Identification

Drawing

Dimensions in mm

Male connector
9 – 50 contacts

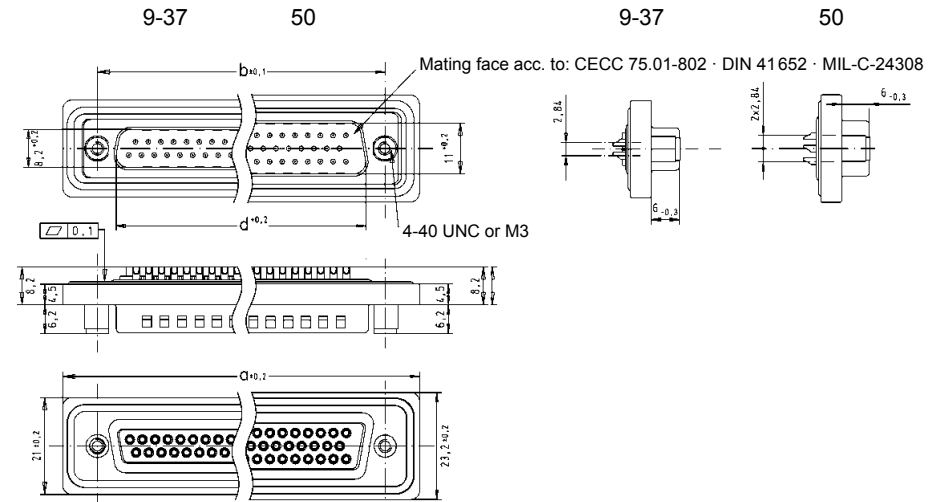

Female connector
9 – 50 contacts

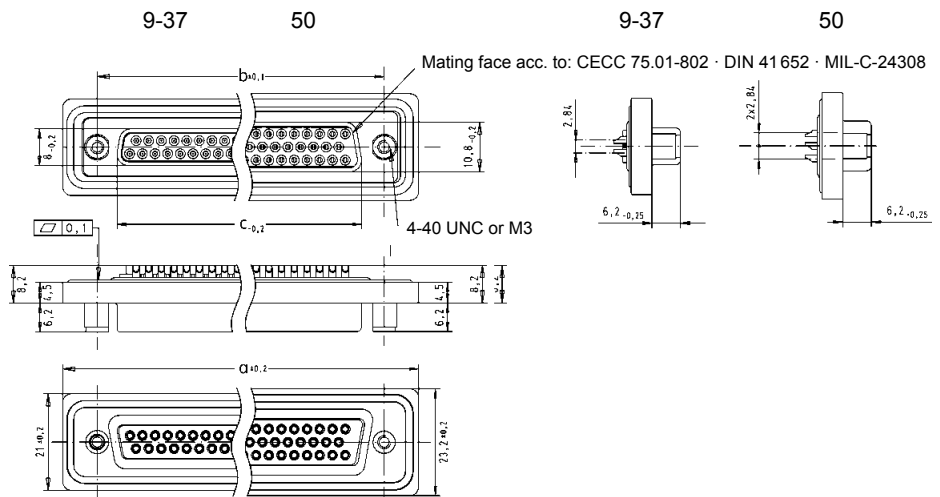

	a	b	c	d
9	40.0	25.00	16.4	16.9
15	48.3	33.30	24.7	25.2
25	62.0	47.04	38.5	38.9
37	78.5	63.50	54.9	55.3
50	76.1	61.10	51.3	52.8

Panel cut out
for front/rear mount

Values are taken from the
CECC 75301-802

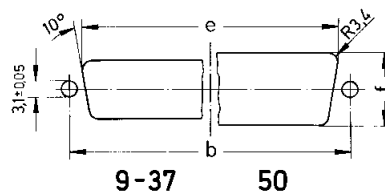

Front mount

	$b_{\pm 0.13}$	$e_{\pm 0.2}$	$f_{\pm 0.2}$
9	25.0	22.2	12.3
15	33.3	30.5	12.3
25	47.0	44.3	12.3
37	63.5	60.7	12.3
50	61.1	58.3	15.1

Rear mount

	$b_{\pm 0.13}$	$e_{\pm 0.2}$	$f_{\pm 0.2}$
9	25.0	20.5	11.4
15	33.3	28.8	11.4
25	47.0	42.5	11.4
37	63.5	59.1	11.4
50	61.1	56.3	14.1

Number of contacts

9-25



IP67, straight turned solder pins,
with rear plastic mounting plate, spacer and board lock

Identification	No. of contacts	Part number
S4 ¹⁾		
Male connector metal shell with dimples Please insert digit for flange thread 4-40 UNC ▶ 7 M3 ▶ 9	9 15 25	09 67 509 . 675 09 67 515 . 675 09 67 525 . 675
Female connector metal shell Please insert digit for flange thread 4-40 UNC ▶ 6 M3 ▶ 8	9 15 25	09 67 509 . 775 09 67 515 . 775 09 67 525 . 775

¹⁾ S4 = 0.76 µm (30 µinch) Au or PdNi equivalent

Number of contacts

9-25



IP67, straight turned solder pins, with rear plastic mounting plate, spacer and board lock

Identification

Drawing

Dimensions in mm

Male connector
9 – 25 contacts

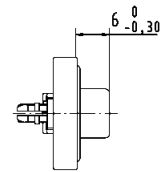
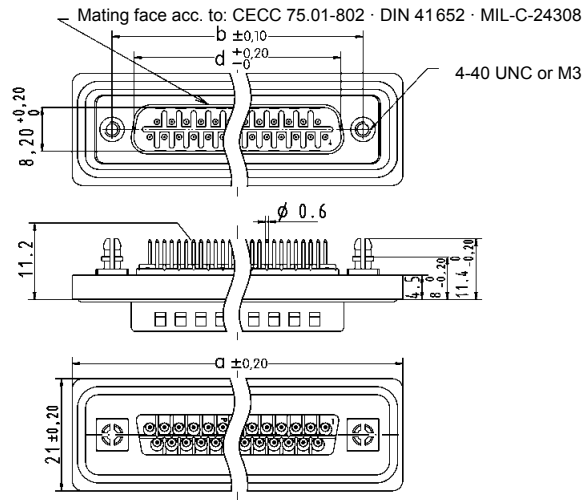

Female connector
9 – 25 contacts

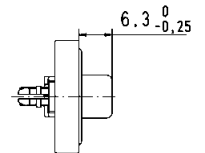
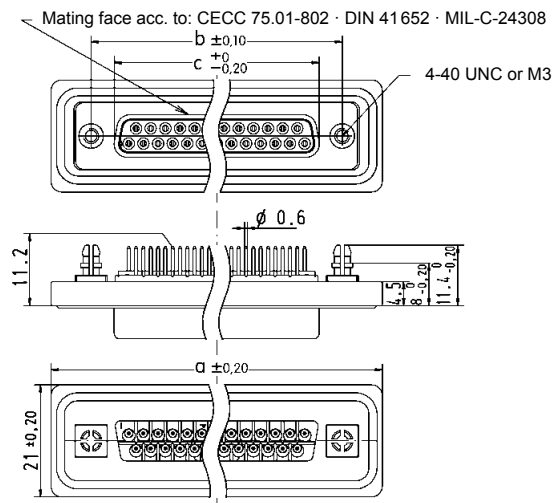

	a	b	c	d	g	h	i
9	40.0	25.00	16.4	16.9	4 x 2.74 = 10.96	3 x 2.74 = 8.22	25.0
15	48.3	33.30	24.7	25.2	7 x 2.74 = 19.18	6 x 2.74 = 16.44	33.3
25	62.0	47.04	38.5	38.9	12 x 2.76 = 33.12	11 x 2.76 = 30.36	47.0

Board drillings

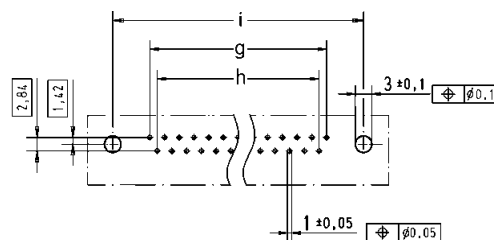

Number of contacts

9-50



IP67, straight turned solder pins,
with rear metal mounting plate, spacer and board lock

Identification	No. of contacts	Part number
		S4 ¹⁾
Male connector metal shell with dimples Please insert digit for flange thread 4-40 UNC ▶ 7 M3 ▶ 9	9 15 25 37 50	09 67 609 . 675 09 67 615 . 675 09 67 625 . 675 09 67 637 . 675 09 67 650 . 675
Female connector metal shell Please insert digit for flange thread 4-40 UNC ▶ 6 M3 ▶ 8	9 15 25 37 50	09 67 609 . 775 09 67 615 . 775 09 67 625 . 775 09 67 637 . 775 09 67 650 . 775

¹⁾ S4 = 0.76 µm (30 µinch) Au or PdNi equivalent

Number of contacts

9–50



IP67, straight turned solder pins, with rear metal mounting plate, spacer and board lock

Identification

Drawing

Dimensions in mm

Male connector
9 – 50 contacts

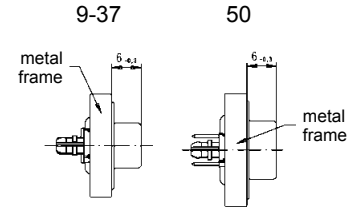
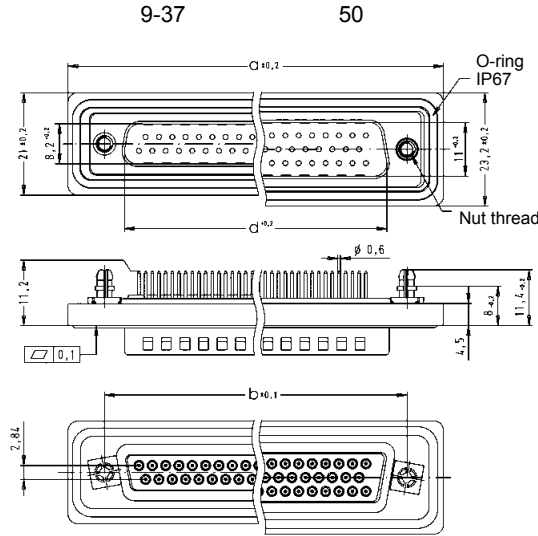

Female connector
9 – 50 contacts

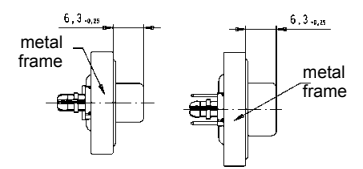
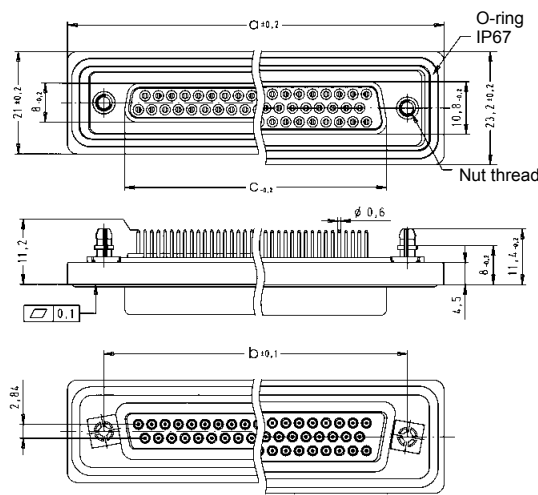

	a	b	c	d	g	h
9	40.0	25.00	16.4	16.9	4 x $\boxed{2.74} = \boxed{10.96}$	3 x $\boxed{2.74} = \boxed{8.22}$
15	48.3	33.30	24.7	25.2	7 x $\boxed{2.74} = \boxed{19.18}$	6 x $\boxed{2.74} = \boxed{16.44}$
25	62.0	47.04	38.5	38.9	12 x $\boxed{2.76} = \boxed{33.12}$	11 x $\boxed{2.76} = \boxed{30.36}$
37	78.5	63.50	54.9	55.3	18 x $\boxed{2.76} = \boxed{49.68}$	17 x $\boxed{2.76} = \boxed{46.92}$
50	76.1	61.10	52.5	52.8	16 x $\boxed{2.76} = \boxed{44.16}$	15 x $\boxed{2.76} = \boxed{41.40}$

Board drillings

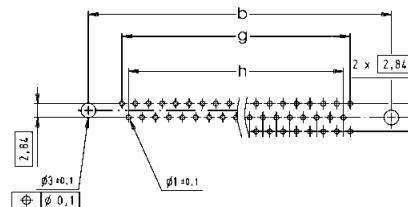

D-Sub

Number of contacts

9-25



IP67, angled turned solder pins,
with rear plastic mounting plate, bracket and board lock

Identification	No. of contacts	Part number
		S4 ¹⁾
Male connector metal shell with dimples Please insert digit for flange thread 4-40 UNC ▶ 7 M3 ▶ 9	9 15 25	09 67 509 . 658 09 67 515 . 658 09 67 525 . 658
Female connector metal shell Please insert digit for flange thread 4-40 UNC ▶ 6 M3 ▶ 8	9 15 25	09 67 509 . 758 09 67 515 . 758 09 67 525 . 758

¹⁾ S4 = 0.76 µm (30 µinch) Au or PdNi equivalent

Number of contacts

9-25



IP67, angled turned solder pins, with rear plastic mounting plate, bracket and board lock

Identification

Drawing

Dimensions in mm

Male connector
9 – 25 contacts

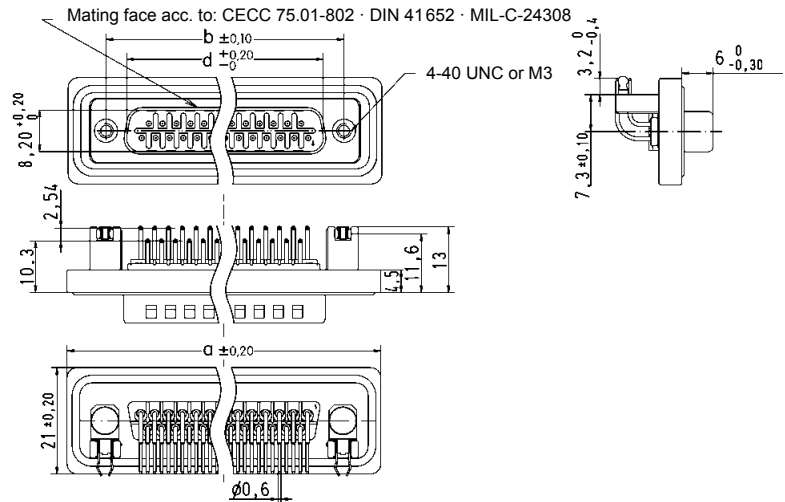

Female connector
9 – 25 contacts

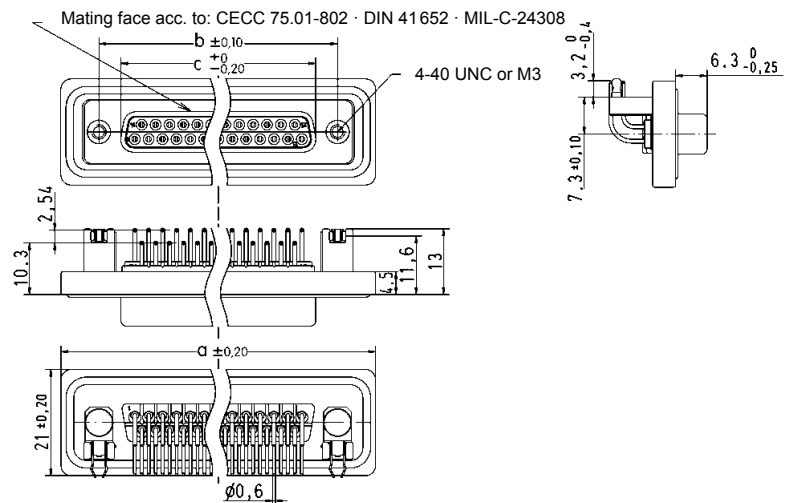

	a	b	c	d	g	h	i
9	40.0	25.00	16.4	16.9	4 x 2.74 = 10.96	3 x 2.74 = 8.22	25.0
15	48.3	33.30	24.7	25.2	7 x 2.74 = 19.18	6 x 2.74 = 16.44	33.3
25	62.0	47.04	38.5	38.9	12 x 2.76 = 33.12	11 x 2.76 = 30.36	47.0

Board drillings

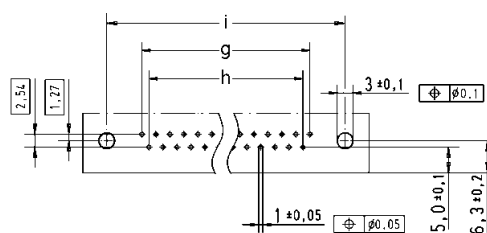

Number of contacts

9-50

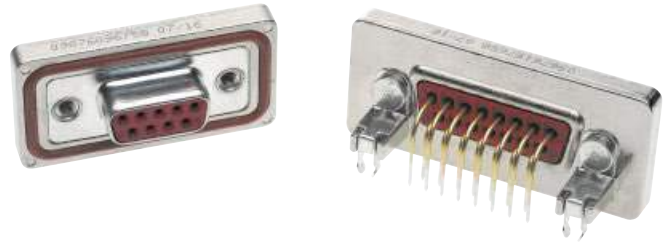

IP67, angled turned solder pins,
with rear metal mounting plate, bracket and board lock

Identification	No. of contacts	Part number
		S4 ¹⁾
Male connector metal shell with dimples Please insert digit for flange thread 4-40 UNC ▶ 7 M3 ▶ 9	9 15 25 37 50	09 67 609 . 658 09 67 615 . 658 09 67 625 . 658 09 67 637 . 658 09 67 650 . 658
Female connector metal shell Please insert digit for flange thread 4-40 UNC ▶ 6 M3 ▶ 8	9 15 25 37 50	09 67 609 . 758 09 67 615 . 758 09 67 625 . 758 09 67 637 . 758 09 67 650 . 758

¹⁾ S4 = 0.76 µm (30 µinch) Au or PdNi equivalent

Number of contacts

9-50

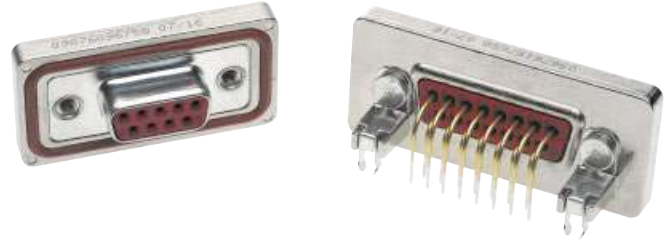

IP67, angled turned solder pins, with rear metal mounting plate, bracket and board lock

Identification

Drawing

Dimensions in mm

Male connector
9 – 50 contacts

Female connector
9 – 50 contacts

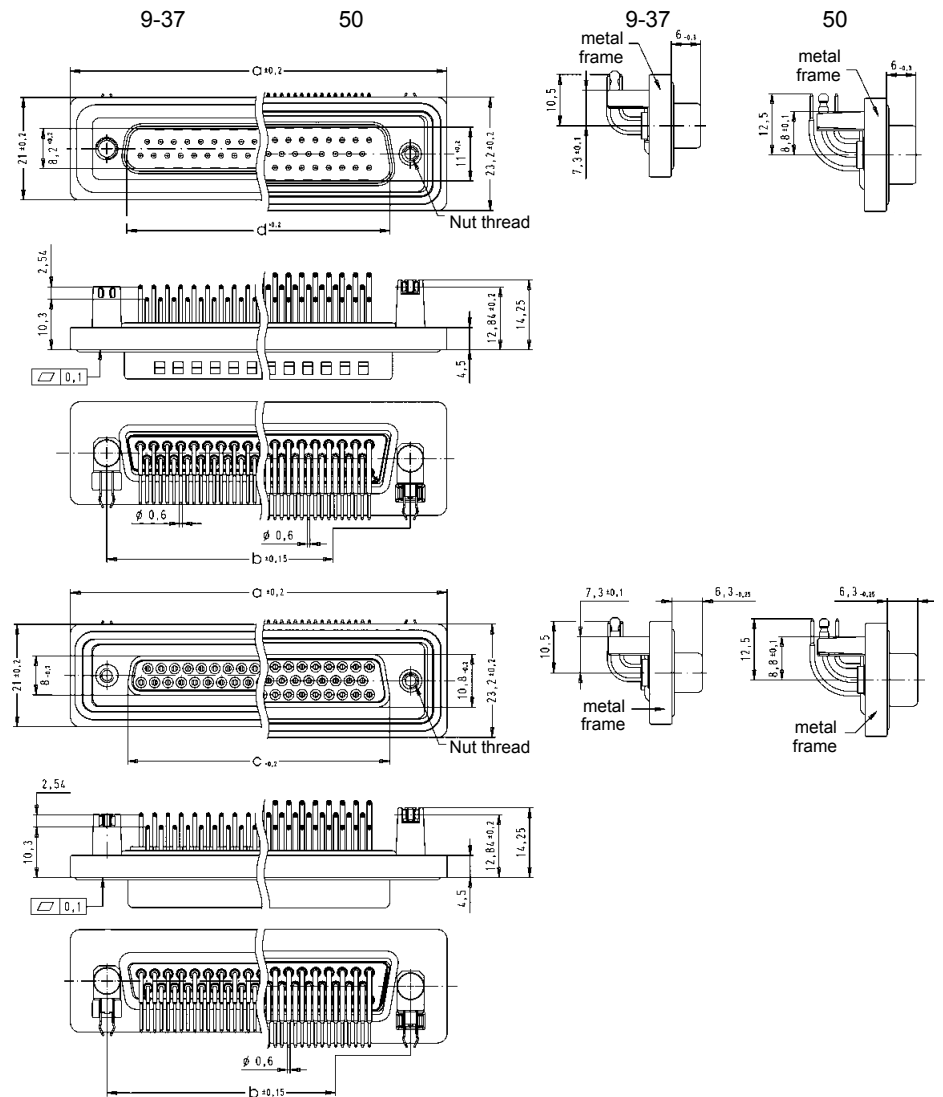

	a	b	c	d	g	h
9	40.0	25.00	16.4	16.9	4 x 2.74 = 10.96	3 x 2.74 = 8.22
15	48.3	33.30	24.7	25.2	7 x 2.74 = 19.18	6 x 2.74 = 16.44
25	62.0	47.04	38.5	38.9	12 x 2.76 = 33.12	11 x 2.76 = 30.36
37	78.5	63.50	54.9	55.3	18 x 2.76 = 49.68	17 x 2.76 = 46.92
50	76.1	61.10	52.5	52.8	16 x 2.76 = 44.16	15 x 2.76 = 41.40

Board drillings

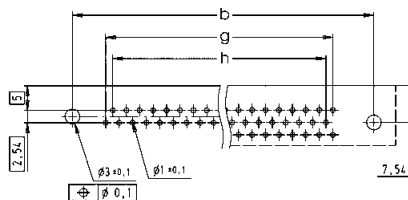



IP67 plastic hoods
IP67 metallized plastic hoods
for rear mount

Identification	No. of contacts	Part number	Drawing	Dimensions in mm
----------------	-----------------	-------------	---------	------------------

Hood ¹⁾ Black thermoplastic	9	09 67 009 043		
	15	09 67 015 043		
	25	09 67 025 043		
	37	09 67 037 043		
	50	09 67 050 043		

Metallized thermo- plastic	9	09 67 009 053		
	15	09 67 015 053		
	25	09 67 025 053		
	37	09 67 037 053		
	50	09 67 050 053		

Please insert digit
for screw option

- Locking screw,
thread 4-40 UNC ▶ 8
- Locking screw,
thread M3 ▶ 9









Mounting instructions:

- The peeled back cable braiding must not extend over the cable clamp, in order not to damage the gasket or to impair its performance.
- Pull back cable until cable clamp snaps into shielding plate.
- Snap connector into hood.

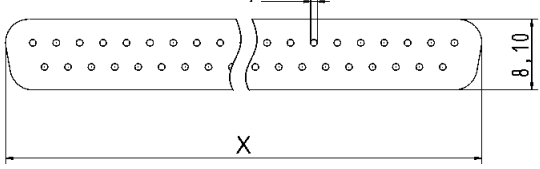
	a	b	c	d	e	f	g	h	i	Ø	
										min.	max.
9	20	16.5	13.0	20.2	22.1	36.4	25.0	39.8	18.0	6.0	8.0
15	24	16.5	13.0	20.2	26.6	36.4	33.3	48.5	18.0	6.0	10.5
25	24	20.3	13.0	24.0	26.6	43.6	47.0	62.3	45.0	8.0	12.0
37	24	20.3	13.0	24.0	26.6	52.1	63.5	78.6	60.0	8.0	12.0
50	29	22.0	16.0	27.6	32.1	52.1	61.1	75.7	60.0	9.0	14.0

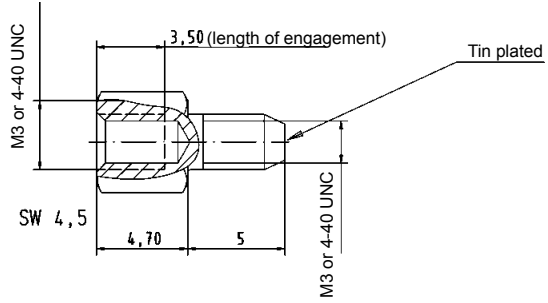
¹⁾ Not to be used with 9 to 50-pole crimp connectors

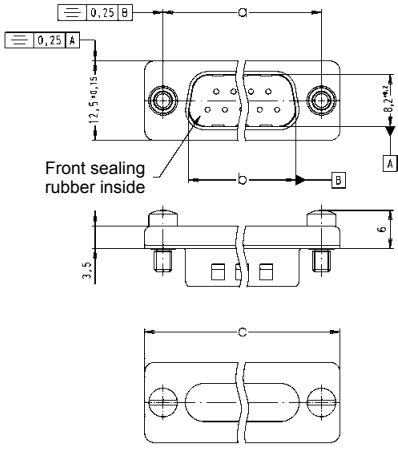
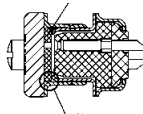
Accessories for IP67 connectors

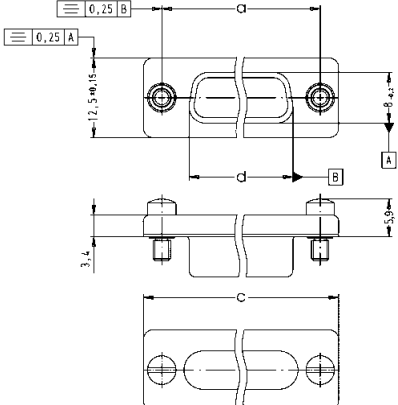
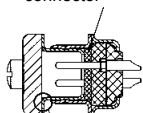
Identification	No. of contacts	Part number	Drawing	Dimensions in mm																				
Front sealing rubber¹⁾ IP67  Mounting example 	9 15 25	09 67 002 9001 09 67 002 9002 09 67 002 9003		<table border="1"> <thead> <tr> <th></th> <th>X</th> </tr> </thead> <tbody> <tr> <td>9</td> <td>16.7</td> </tr> <tr> <td>15</td> <td>24.8</td> </tr> <tr> <td>25</td> <td>38.8</td> </tr> </tbody> </table>		X	9	16.7	15	24.8	25	38.8												
	X																							
9	16.7																							
15	24.8																							
25	38.8																							
Female screw lock and spacing washer²⁾ M3  4-40 UNC 2) Order 2 for each connector		09 67 002 9006 09 67 002 9007																						
Dust cap for female connectors³⁾ M3  4-40 UNC 3) With inside glued front sealing rubber	9 15 25 9 15 25	09 67 002 9055 09 67 002 9056 09 67 002 9057 09 67 002 9050 09 67 002 9051 09 67 002 9052	 <p>IP67 shielding concept Front seal glued to shielding dust cap</p>  <p>Detail X (Scale 5:1)</p> <table border="1"> <thead> <tr> <th></th> <th>a</th> <th>b</th> <th>c</th> <th>d</th> </tr> </thead> <tbody> <tr> <td>9</td> <td>25.00</td> <td>16.9</td> <td>30.8</td> <td>16.4</td> </tr> <tr> <td>15</td> <td>33.30</td> <td>25.2</td> <td>39.1</td> <td>24.7</td> </tr> <tr> <td>25</td> <td>47.04</td> <td>38.9</td> <td>53.0</td> <td>38.5</td> </tr> </tbody> </table>		a	b	c	d	9	25.00	16.9	30.8	16.4	15	33.30	25.2	39.1	24.7	25	47.04	38.9	53.0	38.5	
	a	b	c	d																				
9	25.00	16.9	30.8	16.4																				
15	33.30	25.2	39.1	24.7																				
25	47.04	38.9	53.0	38.5																				
for male connectors⁴⁾ M3  4-40 UNC 4) Order separately the front sealing rubber for an IP67 performance	9 15 25 9 15 25	09 67 002 9065 09 67 002 9066 09 67 002 9067 09 67 002 9060 09 67 002 9061 09 67 002 9062	 <p>IP67 shielding concept Front sealing rubber is mounted in male connector</p>  <p>sealed</p> <p>Detail Y (Scale 5:1)</p>																					

1) The front sealing rubber is to be used with hood 09 67 0xx 0436 and 09 67 0xx 0437 when a mated system needs to have the IP67 performance; in this case, the front sealing rubber is positioned in the IP67 male connector prior to the mating operation with the facing IP67 connector; it provides a full protection of the contacts at the mated area by preventing possible ingress of liquids or dust between the shells.



IP67 plastic hoods
IP67 metallized plastic hoods

Identification	No. of contacts	Part number	Drawing	Dimensions in mm
----------------	-----------------	-------------	---------	------------------

D-Sub

Hood
Black thermoplastic

9	09 67 009 0436
15	09 67 015 0436
25	09 67 025 0436

Metallized
thermoplastic

9	09 67 009 0437
15	09 67 015 0437
25	09 67 025 0437

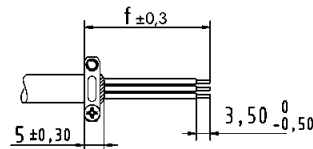
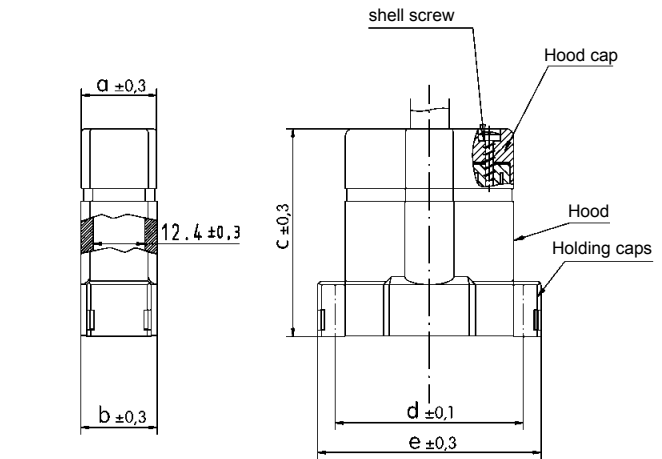





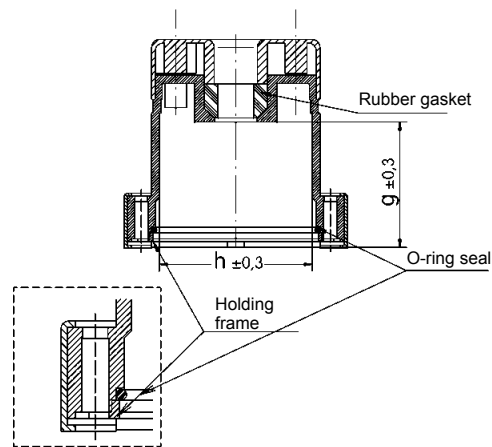
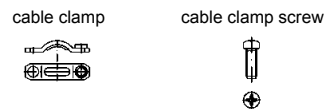

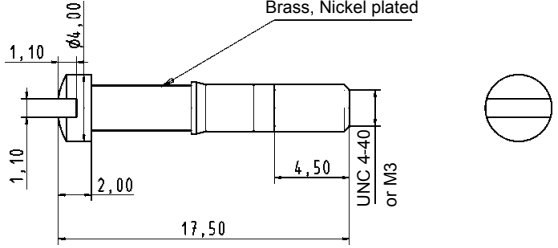

Mounting instructions

The stripped braid should not be fold back to avoid damaging the cable clamp and reducing its performance.

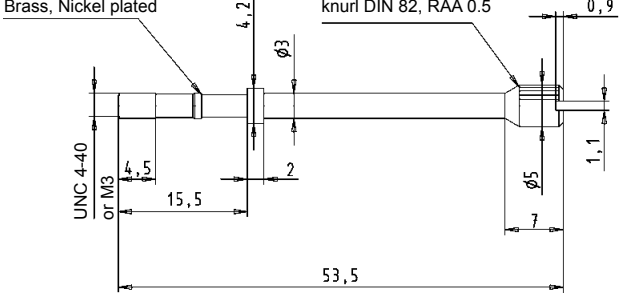
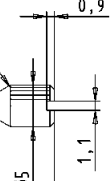

	a	b	c	d	e	f	g	h
9	15.6	15.6	41.0	25.00	33.6	23.0	25.0	17.0
15	15.6	15.6	46.8	33.30	42.0	27.5	30.8	25.1
25	18.8	19.1	52.0	47.04	55.7	31.5	33.8	38.8

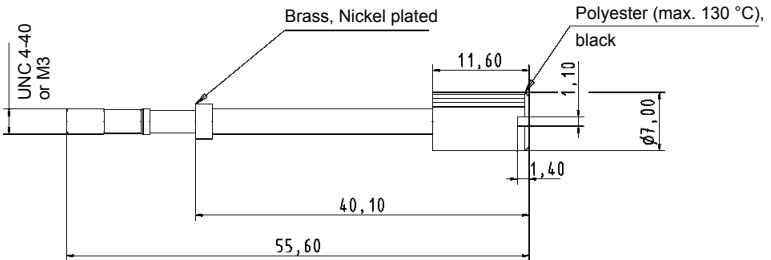
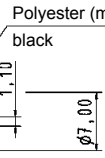
Accessories for IP67 hoods

Identification	Part number	Drawing	Dimensions in mm
Short locking screw 4-40 UNC 	09 67 002 9008		
Short locking screw M3 	09 67 002 9009		
Knurled locking screw 4-40 UNC 	09 67 002 9010		
Knurled locking screw M3 	09 67 002 9011		
Knurled locking screw 4-40 UNC with plastic cap 	09 67 002 9012		
Knurled locking screw M3 with plastic cap 	09 67 002 9013		

D-Sub

HARTING – Guarantee a secure connection

Modern electronic applications demand a high degree of mechanical and electrical security.

To meet these requirements, continuous screening from the cable to the PCB via the connector is achieved by using state of the art components to DIN 41 652.

HARTING offer many solutions. These utilise various combinations of male and female connectors with hoods, featuring either screw locking or latching facilities.

Only 2 examples are shown:

- Continuous security screening and grounding with screw locking and metallized hood.
- Continuous grounding and vibration proof latching system with metallized hood.

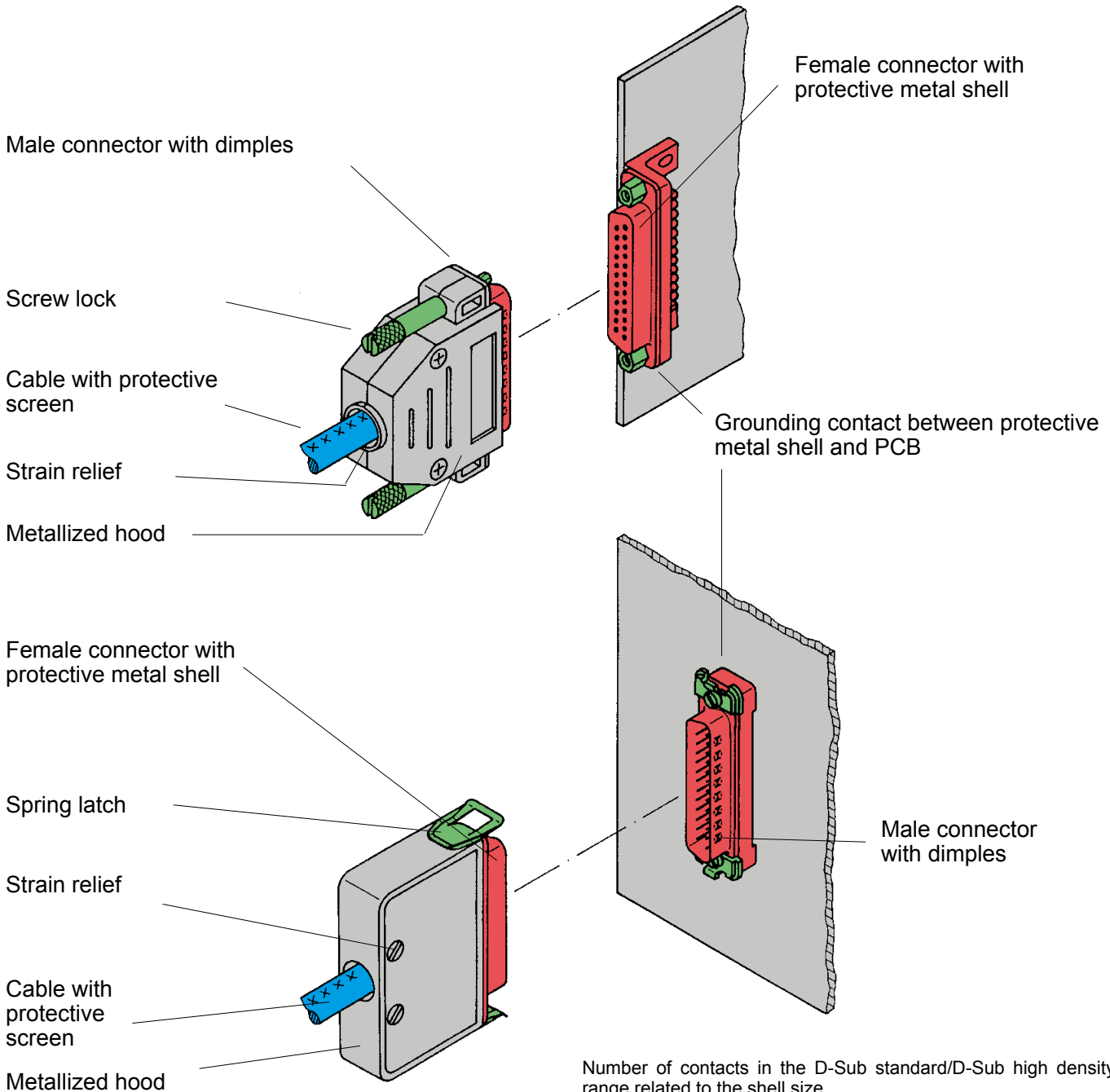

Number of contacts in the D-Sub standard/D-Sub high density range related to the shell size.

Shell size	D-Sub standard	D-Sub high density
1	9	15
2	15	26
3	25	44
4	37	62
5	50	78

D-Sub

Connector hoods for screw locking

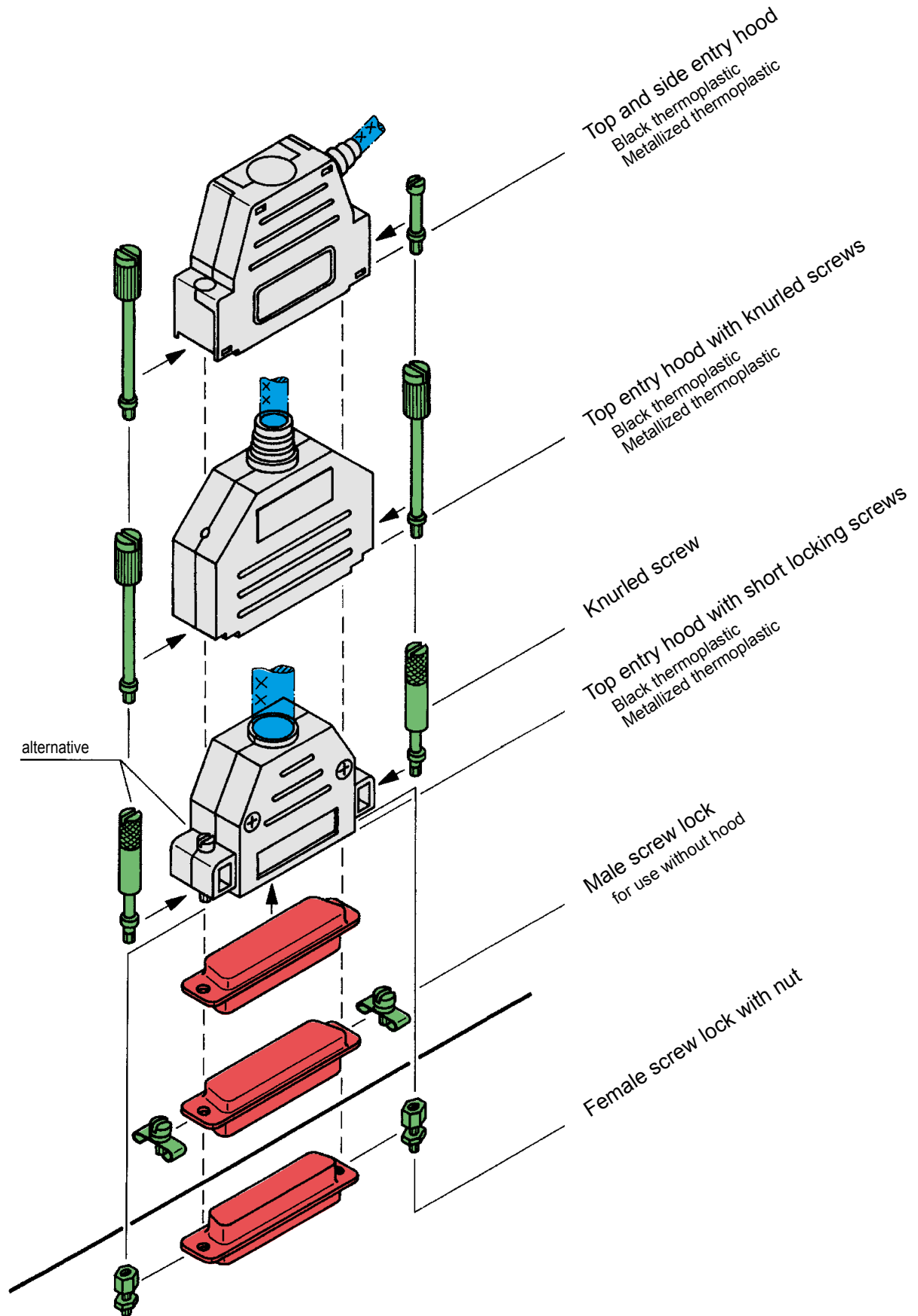



Top and side entry hoods with knurled screws

D-Sub

Identification No. of contacts Part number Drawing Dimensions in mm

Top entry hood Black thermoplastic	9	09 67 009 042
	15	09 67 015 042
Please insert digit for screw option	25	09 67 025 042
	37	09 67 037 042
Knurled screw, thread 4-40 UNC ▶ 4	50	09 67 050 042
Knurled screw, thread M3 ▶ 6		

	A1	A2	B	C1	C2	max. Ø 1	max. Ø 2
9	31.5	32.5	15	34	38	8.0	11.5
15	40.0	41.0	15	34	38	11.5	11.5
25	53.5	54.5	15	40	40	11.5	11.5
37	71.0	71.0	15	40	40	11.5	11.5
50	67.5		19	40		14.0	

Top entry hood Metallized thermoplastic	9	09 67 009 042
	15	09 67 015 042
	25	09 67 025 042
	37	09 67 037 042
Please insert digit for screw option		
Knurled screw, thread 4-40 UNC ▶ 5		
Knurled screw, thread M3 ▶ 7		

C1: non-metallized C2: metallized

max. Ø: 3.3, 4.3, 5.3, 6.3

max. Ø: 7.3, 8.3, 9.3, 10.3

Cut appropriate cable entry to fit actual cable diameter

Top and side entry hood Black thermoplastic	9 ³⁾	09 67 009 043
	15	09 67 015 043
	25	09 67 025 043
	37 ¹⁾	09 67 037 043
Please insert digit for screw option		
Knurled screw, thread 4-40 UNC ▶ 4		
Knurled screw, thread M3 ▶ 0		

Optional jack screw

Cable diameters: Ø 3.3, Ø 4.3, Ø 5.3, Ø 6.3, Ø 7.3, Ø 8.3, Ø 9.3, Ø 10.3

Cover in place of grommet

Top and side entry hood Metallized thermoplastic	9 ³⁾	09 67 009 043
	15	09 67 015 043
	25 ²⁾	09 67 025 043
	37 ¹⁾	09 67 037 043
Please insert digit for screw option		
Knurled screw, thread 4-40 UNC ▶ 5		
Knurled screw, thread M3 ▶ 1		

	A	B
9	31.5	40
15	40.0	40
25	53.5	43
37	71.3	40

- 37-pole is only available with side entry and with knurled screw, thread 4-40 UNC
- Cable clamp kit for two outputs is available as accessories (it includes: screw, metal clamp, plastic insert and grommet). With Part number 09 67 001 9988 ten of these kits are delivered.
- 9-pole hood provided with only one screw on the opposite side of the cable entry.



Top and side entry hoods with short screws

Identification	No. of contacts	Part number	Drawing	Dimensions in mm															
Top and side entry hood Black thermoplastic	9 ¹⁾ 15 25 37	09 67 009 046 . 09 67 015 046 . 09 67 025 046 . 09 67 037 046 .		<table border="1"> <thead> <tr> <th></th> <th>A</th> <th>B</th> </tr> </thead> <tbody> <tr> <td>9</td> <td>31.5</td> <td>40</td> </tr> <tr> <td>15</td> <td>40.0</td> <td>40</td> </tr> <tr> <td>25</td> <td>53.5</td> <td>43</td> </tr> <tr> <td>37</td> <td>71.3</td> <td>40</td> </tr> </tbody> </table>		A	B	9	31.5	40	15	40.0	40	25	53.5	43	37	71.3	40
	A	B																	
9	31.5	40																	
15	40.0	40																	
25	53.5	43																	
37	71.3	40																	
Please insert digit for screw option Short screw, thread 4-40 UNC ▶ 3 Short screw, thread M3 ▶ 2																			
Top and side entry hood Metallized thermoplastic	9 ¹⁾ 15 25 37	09 67 009 046 . 09 67 015 046 . 09 67 025 046 . 09 67 037 046 .		<table border="1"> <thead> <tr> <th></th> <th>A</th> <th>B</th> </tr> </thead> <tbody> <tr> <td>9</td> <td>31.5</td> <td>40</td> </tr> <tr> <td>15</td> <td>40.0</td> <td>40</td> </tr> <tr> <td>25</td> <td>53.5</td> <td>43</td> </tr> <tr> <td>37</td> <td>71.3</td> <td>40</td> </tr> </tbody> </table>		A	B	9	31.5	40	15	40.0	40	25	53.5	43	37	71.3	40
	A	B																	
9	31.5	40																	
15	40.0	40																	
25	53.5	43																	
37	71.3	40																	
Please insert digit for screw option Short screw, thread 4-40 UNC ▶ 5 Short screw, thread M3 ▶ 4																			

D-Sub

¹⁾ 9-pole hood provided with only one screw on the opposite side of the cable entry.
 Operating temperature for all hoods on this page: -55 °C ... +110 °C

Scope of delivery and spare parts



	Knurled screw M3, beige	Knurled screw 4-40 UNC, beige	Knurled screw M3, black	Knurled screw 4-40 UNC, black	Cable clamp, small	Cable clamp, large	Cable clamp screw	Metallized insert, small
Part number	09 67 002 9152	09 67 002 9081	09 67 001 9961	09 67 002 9024	09 67 002 9104	09 67 002 9106	09 67 002 9102	09 67 002 9103
09 67 009 0424				2	1		2	
09 67 015 0424				2		1	2	
09 67 025 0424				2		1	2	
09 67 037 0424				2		1	2	
09 67 050 0424				2		1	2	
09 67 009 0426			2		1		2	
09 67 015 0426			2			1	2	
09 67 025 0426			2			1	2	
09 67 037 0426			2			1	2	
09 67 050 0426			2			1	2	
09 67 009 0425		2			1		2	1
09 67 015 0425		2				1	2	
09 67 025 0425		2				1	2	
09 67 037 0425		2				1	2	
09 67 009 0427	2				1		2	1
09 67 015 0427	2					1	2	
09 67 025 0427	2					1	2	
09 67 037 0427	2					1	2	
	Knurled screw M3, beige	Knurled screw 4-40 UNC, beige	Knurled screw M3, black	Knurled screw 4-40 UNC, black	Short screw M3, 18 mm	Short screw 4-40 UNC, 18 mm	Short screw M3, 12 mm	Short screw 4-40 UNC, 12 mm
Part number	09 67 002 9152	09 67 002 9081	09 67 001 9961	09 67 002 9024	09 67 002 9163	09 67 001 9979	09 67 002 9162	09 67 002 9078
09 67 009 0434				1				
09 67 015 0434				1				1
09 67 025 0434				1		1		
09 67 037 0434								1
09 67 009 0430			1					
09 67 015 0430			1				1	
09 67 025 0430			1		1			
09 67 009 0435		1						
09 67 015 0435		1						1
09 67 025 0435		1				1		
09 67 037 0435								1
09 67 009 0431	1							
09 67 015 0431	1						1	
09 67 025 0431	1				1			
09 67 009 0463						1		
09 67 015 0463								2
09 67 025 0463						2		
09 67 037 0463								2
09 67 009 0462					1			
09 67 015 0462							2	
09 67 025 0462					2			
09 67 037 0462							2	
09 67 009 0465						1		
09 67 015 0465								2
09 67 025 0465						2		
09 67 037 0465								2
09 67 009 0464					1			
09 67 015 0464							2	
09 67 025 0464					2			
09 67 037 0464							2	

D-Sub

Scope of delivery and spare parts



	Metallized insert, large	Small plastic insert, black	Large plastic insert, black	Grommet kit, metallized	Grommet kit, black (optional)	Rubber grommet, small (optional)	Rubber grommet, large (optional)
Part number	09 67 002 9105	09 67 002 9150	09 67 002 9151	09 67 002 9075	09 67 001 9968	09 67 002 9119	09 67 001 9981
09 67 009 0424		1			1	1	
09 67 015 0424			1		1		1
09 67 025 0424			1		1		1
09 67 037 0424			1		1		1
09 67 050 0424			1		1		no
09 67 009 0426		1			1	1	
09 67 015 0426			1		1		1
09 67 025 0426			1		1		1
09 67 037 0426			1		1		1
09 67 050 0426			1		1		no
09 67 009 0425							
09 67 015 0425	1			1			
09 67 025 0425	1			1			
09 67 037 0425	1			1			
09 67 009 0427							
09 67 015 0427	1			1			
09 67 025 0427	1			1			
09 67 037 0427	1			1			
	Cable clamp, small	Cable clamp screw	Metallized insert, small	Small plastic insert, black	Grommet kit, metallized	Plastic plug, metallized	Plastic plug, black
Part number	09 67 002 9104	09 67 002 9102	09 67 002 9103	09 67 002 9150	09 67 002 9075	09 67 001 9980	09 67 002 9161
09 67 009 0434	1	2		1			1
09 67 015 0434	1	2		1			1
09 67 025 0434	1	2		1			1
09 67 037 0434	1	2		1			
09 67 009 0430	1	2		1			1
09 67 015 0430	1	2		1			1
09 67 025 0430	1	2		1			1
09 67 009 0435	1	2	1		1	1	
09 67 015 0435	1	2	1		1	1	
09 67 025 0435	1	2	1		1	1	
09 67 037 0435	1	2	1		1	N/A	
09 67 009 0431	1	2	1		1	1	
09 67 015 0431	1	2	1		1	1	
09 67 025 0431	1	2	1		1	1	
09 67 009 0463	1	2		1			1
09 67 015 0463	1	2		1			1
09 67 025 0463	1	2		1			1
09 67 037 0463	1	2		1			N/A
09 67 009 0462	1	2		1			1
09 67 015 0462	1	2		1			1
09 67 025 0462	1	2		1			1
09 67 037 0462	1	2		1			N/A
09 67 009 0465	1	2	1		1	1	
09 67 015 0465	1	2	1		1	1	
09 67 025 0465	1	2	1		1	1	
09 67 037 0465	1	2	1		1	N/A	
09 67 009 0464	1	2	1		1	1	
09 67 015 0464	1	2	1		1	1	
09 67 025 0464	1	2	1		1	1	
09 67 037 0464	1	2	1		1	N/A	

D-Sub



Side entry hoods with knurled screws

Identification	No. of contacts	Part number	Drawing	Dimensions in mm
----------------	-----------------	-------------	---------	------------------

D-Sub

Hood ¹⁾ grey thermoplastic RAL 7032	9	09 67 009 0571	<p>Upper hood part</p> <p>9 contacts</p>	<p>Lower hood part</p>			
	15	09 67 015 0571					
	25	09 67 025 0571					
	37	09 67 037 0571					
	50	09 67 050 0571					
	grey thermoplastic with internal tin-plate screening	9			09 67 009 0573	<p>15 – 50 contacts</p>	
		15			09 67 015 0573		
		25			09 67 025 0573		
		37			09 67 037 0573		
		50			09 67 050 0573		
9-37 way for packaging density of 3 TE (15.24 mm)							

	a max.	b min.	c	d	e	f
15	39.62	28.40	13.00	14.00	1.00	7.50
25	53.52	42.20	13.00	14.00	1.00	7.50
37	69.80	58.65	13.00	14.00	1.00	7.50
50	67.41	56.18	16.00	17.50	1.50	9.50

Knurled screw	9-50	09 67 000 9971 ²⁾ 09 67 001 9965*	<p>Grey head / Nickel plated steel</p>
Thread UNC Thread M3			
Thread UNC Thread M3	9-50	09 67 001 9978 09 67 001 9977	

Tooling for assembly of hoods			
Bottom part		09 99 000 0216*	

05
146

* Not normally kept in stock
¹⁾ Order knurled screw separately
²⁾ 9 way 1 per hood – 15-50 way 2 per hood

³⁾ Screw driver type ISO PH 1 for philips screw No 1 ISO norm 4757
 Operating temperature for all hoods on this page: -30 °C ... +100 °C



Top entry hoods with knurled or locking screws

Identification	No. of contacts	Part number	Drawing	Dimensions in mm																																										
Hood³⁾ Black thermoplastic with short locking screws	9 15 25 37 50	09 67 009 0442 09 67 015 0442 09 67 025 0442 09 67 037 0442 09 67 050 0442																																												
Hood³⁾ Metallized thermoplastic with short locking screws Please insert digit for screw option Thread 4-40 UNC ▶ 4 Thread M3 ▶ 2	9 15 25 37 50	09 67 009 04 . 3 09 67 015 04 . 3 09 67 025 04 . 3 09 67 037 04 . 3 09 67 050 04 . 3	 <table border="1"> <thead> <tr> <th></th> <th>a</th> <th>b</th> <th>c</th> <th>d</th> <th colspan="2">e</th> </tr> <tr> <th></th> <th></th> <th></th> <th></th> <th></th> <th>min.</th> <th>max.</th> </tr> </thead> <tbody> <tr> <td>15</td> <td>40.0</td> <td>34.7</td> <td>15.2</td> <td>33.3</td> <td>3.3</td> <td>8.5</td> </tr> <tr> <td>25</td> <td>53.2</td> <td>39.7</td> <td>15.2</td> <td>47.0</td> <td>3.5</td> <td>11.0</td> </tr> <tr> <td>37</td> <td>70.0</td> <td>39.7</td> <td>15.2</td> <td>63.5</td> <td>3.5</td> <td>11.0</td> </tr> <tr> <td>50</td> <td>67.5</td> <td>39.7</td> <td>18.2</td> <td>61.1</td> <td>9.3</td> <td>12.0</td> </tr> </tbody> </table>		a	b	c	d	e							min.	max.	15	40.0	34.7	15.2	33.3	3.3	8.5	25	53.2	39.7	15.2	47.0	3.5	11.0	37	70.0	39.7	15.2	63.5	3.5	11.0	50	67.5	39.7	18.2	61.1	9.3	12.0	
	a	b	c	d	e																																									
					min.	max.																																								
15	40.0	34.7	15.2	33.3	3.3	8.5																																								
25	53.2	39.7	15.2	47.0	3.5	11.0																																								
37	70.0	39.7	15.2	63.5	3.5	11.0																																								
50	67.5	39.7	18.2	61.1	9.3	12.0																																								
Knurled screw for metallized hood Thread UNC Thread M3	9-50 9-50	09 67 000 9925 ²⁾ 09 67 000 9930 ²⁾																																												
Screened hood Order cover and internal metal screen separately Cover⁴⁾ Black thermoplastic with knurled screws	9 15 25 37	09 67 009 0422 09 67 015 0422 09 67 025 0422 09 67 037 0422	 <table border="1"> <thead> <tr> <th></th> <th>A</th> <th>B</th> <th>C</th> <th>D</th> </tr> </thead> <tbody> <tr> <td>9</td> <td>35.0</td> <td>54</td> <td>19.1</td> <td>34</td> </tr> <tr> <td>15</td> <td>43.0</td> <td>54</td> <td>19.1</td> <td>34</td> </tr> <tr> <td>25</td> <td>57.5</td> <td>54</td> <td>19.1</td> <td>34</td> </tr> <tr> <td>37</td> <td>74.0</td> <td>54</td> <td>19.1</td> <td>34</td> </tr> </tbody> </table>		A	B	C	D	9	35.0	54	19.1	34	15	43.0	54	19.1	34	25	57.5	54	19.1	34	37	74.0	54	19.1	34																		
	A	B	C	D																																										
9	35.0	54	19.1	34																																										
15	43.0	54	19.1	34																																										
25	57.5	54	19.1	34																																										
37	74.0	54	19.1	34																																										
Internal metal screen⁴⁾ metallized (Crimp tool see chapter 20)	9 15 25 37	09 67 009 0421 09 67 015 0421 09 67 025 0421 09 67 037 0421	 <table border="1"> <thead> <tr> <th rowspan="2"></th> <th colspan="2">Cable Ø (mm)</th> </tr> <tr> <th>min.</th> <th>max.</th> </tr> </thead> <tbody> <tr> <td>9</td> <td>6.1</td> <td>8.8</td> </tr> <tr> <td>15</td> <td>6.1</td> <td>8.8</td> </tr> <tr> <td>25</td> <td>8.0</td> <td>10.3</td> </tr> <tr> <td>37</td> <td>9.5</td> <td>11.5</td> </tr> </tbody> </table>		Cable Ø (mm)		min.	max.	9	6.1	8.8	15	6.1	8.8	25	8.0	10.3	37	9.5	11.5																										
	Cable Ø (mm)																																													
	min.	max.																																												
9	6.1	8.8																																												
15	6.1	8.8																																												
25	8.0	10.3																																												
37	9.5	11.5																																												

1) Use of knurled screws is possible. Please order separately
 2) Order 2 for each hood
 3) Operating temperature: -20 °C ... +90 °C
 4) Operating temperature: -55 °C ... +110 °C

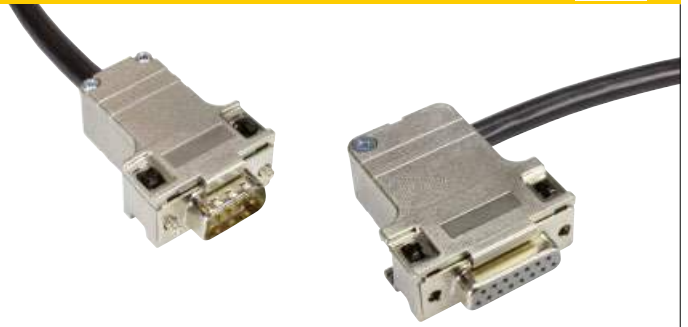

Metallized thermoplastic top and side entry hoods with short screws

Identification No. of contacts Part number Drawing Dimensions in mm

Top entry hood
Short screw,
thread 4-40 UNC

9	09 67 009 0446
15	09 67 015 0446
25	09 67 025 0446
37	09 67 037 0446
50	09 67 050 0446

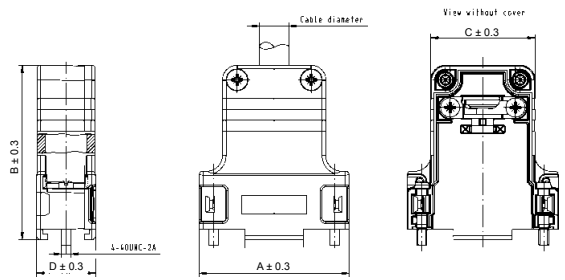

Poles	A	B	C	D	Cable diameter	
					Min.	Max.
9	31.8	41.6	20.0	16.7	4.0	11.0
15	41.2	47.8	28.4	16.2	4.0	11.0
25	54.9	54.8	42.1	16.2	4.0	12.0
37	71.4	57.8	58.6	18.9	6.0	13.0
50	69.0	57.8	56.2	19.5	6.0	14.0

Side entry hood
Short screw,
thread 4-40 UNC

9	09 67 009 0448
15	09 67 015 0448
25	09 67 025 0448
37	09 67 037 0448
50	09 67 050 0448

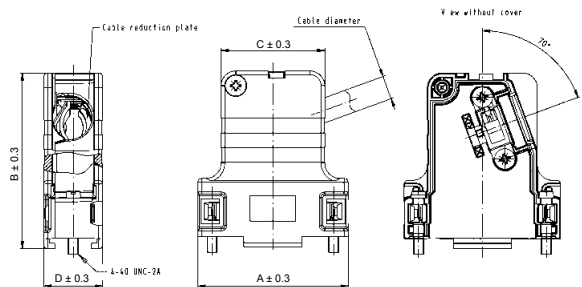



Full metal top and side entry hoods with knurled screws

Identification	No. of contacts	Part number	Drawing	Dimensions in mm																																				
Top entry hood incl. grommet set halves Please insert digit for screw option Knurled screw, thread 4-40 UNC ▶ 3 Knurled screw, thread M3 ▶ 8 Spare knurled screw thread 4-40 UNC thread M3	9 15 25 37 50	09 67 009 034 09 67 015 034 09 67 025 034 09 67 037 034 09 67 050 034		<table border="1"> <thead> <tr> <th>Poles</th> <th>A</th> <th>B</th> <th>C</th> <th>D</th> <th>E</th> </tr> </thead> <tbody> <tr> <td>9</td> <td>31.0</td> <td>39.5</td> <td>14.8</td> <td>25.0</td> <td>11.7</td> </tr> <tr> <td>15</td> <td>39.5</td> <td>41.5</td> <td>14.8</td> <td>33.3</td> <td>11.7</td> </tr> <tr> <td>25</td> <td>53.5</td> <td>48.5</td> <td>14.8</td> <td>47.0</td> <td>11.7</td> </tr> <tr> <td>37</td> <td>71.0</td> <td>53.0</td> <td>14.8</td> <td>63.5</td> <td>11.7</td> </tr> <tr> <td>50</td> <td>67.5</td> <td>54.0</td> <td>18.7</td> <td>61.1</td> <td>17.0</td> </tr> </tbody> </table>	Poles	A	B	C	D	E	9	31.0	39.5	14.8	25.0	11.7	15	39.5	41.5	14.8	33.3	11.7	25	53.5	48.5	14.8	47.0	11.7	37	71.0	53.0	14.8	63.5	11.7	50	67.5	54.0	18.7	61.1	17.0
Poles	A	B	C	D	E																																			
9	31.0	39.5	14.8	25.0	11.7																																			
15	39.5	41.5	14.8	33.3	11.7																																			
25	53.5	48.5	14.8	47.0	11.7																																			
37	71.0	53.0	14.8	63.5	11.7																																			
50	67.5	54.0	18.7	61.1	17.0																																			
Side entry hood incl. grommet set halves Please insert digit for screw option Knurled screw, thread 4-40 UNC ▶ 3 Knurled screw, thread M3 ▶ 6 Spare knurled screw thread 4-40 UNC thread M3	9 ¹⁾ 15 25 37 50	09 67 009 033 09 67 015 033 09 67 025 033 09 67 037 033 09 67 050 033		<table border="1"> <thead> <tr> <th>Poles</th> <th>A</th> <th>B</th> <th>C</th> <th>D</th> <th>E</th> </tr> </thead> <tbody> <tr> <td>9</td> <td>31.0</td> <td>37.7</td> <td>14.7</td> <td>—</td> <td>11.7</td> </tr> <tr> <td>15</td> <td>39.5</td> <td>42.0</td> <td>14.7</td> <td>33.3</td> <td>11.7</td> </tr> <tr> <td>25</td> <td>53.2</td> <td>41.3</td> <td>14.7</td> <td>47.0</td> <td>11.7</td> </tr> <tr> <td>37</td> <td>69.7</td> <td>41.8</td> <td>14.7</td> <td>63.7</td> <td>11.7</td> </tr> <tr> <td>50</td> <td>67.4</td> <td>44.9</td> <td>17.4</td> <td>61.1</td> <td>17.0</td> </tr> </tbody> </table>	Poles	A	B	C	D	E	9	31.0	37.7	14.7	—	11.7	15	39.5	42.0	14.7	33.3	11.7	25	53.2	41.3	14.7	47.0	11.7	37	69.7	41.8	14.7	63.7	11.7	50	67.4	44.9	17.4	61.1	17.0
Poles	A	B	C	D	E																																			
9	31.0	37.7	14.7	—	11.7																																			
15	39.5	42.0	14.7	33.3	11.7																																			
25	53.2	41.3	14.7	47.0	11.7																																			
37	69.7	41.8	14.7	63.7	11.7																																			
50	67.4	44.9	17.4	61.1	17.0																																			
Spare grommet set halves 9-37 poles 50 poles		09 67 002 9092 09 67 002 9094		<table border="1"> <thead> <tr> <th colspan="3">Grommet dimensions</th> </tr> <tr> <th rowspan="2">Number</th> <th colspan="2">Diameter F</th> </tr> <tr> <th>9-37 poles</th> <th>50 poles</th> </tr> </thead> <tbody> <tr> <td>1</td> <td>4.0</td> <td>15.0</td> </tr> <tr> <td>2</td> <td>5.0</td> <td>14.0</td> </tr> <tr> <td>3</td> <td>7.0</td> <td>12.5</td> </tr> <tr> <td>4</td> <td>9.0</td> <td>11.0</td> </tr> <tr> <td>5</td> <td>10.2</td> <td>—</td> </tr> </tbody> </table>	Grommet dimensions			Number	Diameter F		9-37 poles	50 poles	1	4.0	15.0	2	5.0	14.0	3	7.0	12.5	4	9.0	11.0	5	10.2	—													
Grommet dimensions																																								
Number	Diameter F																																							
	9-37 poles	50 poles																																						
1	4.0	15.0																																						
2	5.0	14.0																																						
3	7.0	12.5																																						
4	9.0	11.0																																						
5	10.2	—																																						

D-Sub

¹⁾ 9-pole hood provided with only one screw on the opposite side of the cable entry.
 Operating temperature for all hoods on this page: -40 °C ... +120 °C



Full metal top and side entry hoods with short screws

Identification	No. of contacts	Part number	Drawing	Dimensions in mm																																																								
Top entry hood Please insert digit for screw option Locking screw, thread 4-40 UNC ▶ 4 Locking screw, thread M3 ▶ 9	9 15 25 37 50	09 67 009 034 09 67 015 034 09 67 025 034 09 67 037 034 09 67 050 034		<table border="1"> <thead> <tr> <th rowspan="2">Poles</th> <th rowspan="2">A</th> <th rowspan="2">B</th> <th rowspan="2">C</th> <th rowspan="2">D</th> <th colspan="2">Ø F1</th> <th rowspan="2">Ø F2</th> <th rowspan="2">Ø F3</th> </tr> <tr> <th>Min.</th> <th>Max.</th> </tr> </thead> <tbody> <tr> <td>9</td> <td>31.8</td> <td>42.4</td> <td>20.8</td> <td>15.4</td> <td>3.0</td> <td>9.5</td> <td>6.5</td> <td>—</td> </tr> <tr> <td>15</td> <td>40.3</td> <td>43.5</td> <td>23.3</td> <td>15.4</td> <td>3.0</td> <td>8.5</td> <td>6.5</td> <td>12.5</td> </tr> <tr> <td>25</td> <td>54.0</td> <td>47.7</td> <td>31.7</td> <td>15.4</td> <td>3.0</td> <td>8.5</td> <td>8.0</td> <td>12.5</td> </tr> <tr> <td>37</td> <td>70.2</td> <td>50.4</td> <td>48.2</td> <td>18.4</td> <td>3.0</td> <td>12.0</td> <td>9.0</td> <td>15.0</td> </tr> <tr> <td>50</td> <td>67.8</td> <td>50.5</td> <td>45.8</td> <td>18.2</td> <td>3.0</td> <td>12.0</td> <td>9.7</td> <td>15.0</td> </tr> </tbody> </table> <p>* Cable diameter without rubber bushing = Ø F1 Cable diameter with rubber bushing = Ø F2 Cable diameter without rubber bushing and without cable reduction plate = Ø F3</p>	Poles	A	B	C	D	Ø F1		Ø F2	Ø F3	Min.	Max.	9	31.8	42.4	20.8	15.4	3.0	9.5	6.5	—	15	40.3	43.5	23.3	15.4	3.0	8.5	6.5	12.5	25	54.0	47.7	31.7	15.4	3.0	8.5	8.0	12.5	37	70.2	50.4	48.2	18.4	3.0	12.0	9.0	15.0	50	67.8	50.5	45.8	18.2	3.0	12.0	9.7	15.0
Poles	A	B	C	D						Ø F1				Ø F2	Ø F3																																													
					Min.	Max.																																																						
9	31.8	42.4	20.8	15.4	3.0	9.5	6.5	—																																																				
15	40.3	43.5	23.3	15.4	3.0	8.5	6.5	12.5																																																				
25	54.0	47.7	31.7	15.4	3.0	8.5	8.0	12.5																																																				
37	70.2	50.4	48.2	18.4	3.0	12.0	9.0	15.0																																																				
50	67.8	50.5	45.8	18.2	3.0	12.0	9.7	15.0																																																				
Side entry hood Please insert digit for screw option Locking screw, thread 4-40 UNC ▶ 4 Locking screw, thread M3 ▶ 5	9 15 25 37 50	09 67 009 033 09 67 015 033 09 67 025 033 09 67 037 033 09 67 050 033																																																										
Spare short locking screw thread 4-40 UNC thread M3		09 67 002 9090 09 67 002 9091																																																										

D-Sub



Full metal top and side entry hoods with hexagonal screws

Identification No. of contacts Part number Drawing Dimensions in mm

Top entry hood

9	09 67 009 032
15	09 67 015 032
25	09 67 025 032
37	09 67 037 032
50	09 67 050 032

Please insert digit for screw option

Hexagonal screw, thread 4-40 UNC ▶ 0

Hexagonal screw, thread M3 ▶ 1

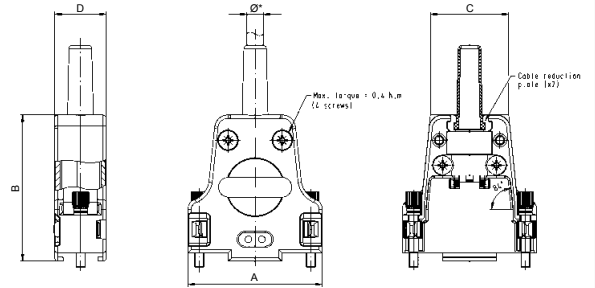

Poles	A	B	C	D	Ø F1		Ø F2	Ø F3
					Min.	Max.		
9	31.6	42.0	20.8	15.2	3.0	9.5	6.5	—
15	40.0	43.5	23.3	15.2	3.0	8.5	6.5	12.5
25	53.7	47.5	31.7	15.2	3.0	8.5	8.0	12.5
37	70.2	50.5	48.2	18.2	3.0	12.0	9.0	15.0
50	67.8	50.5	45.8	18.2	3.0	12.0	9.7	15.0

* Cable diameter without rubber bushing = Ø F1
 Cable diameter with rubber bushing = Ø F2
 Cable diameter without rubber bushing and without cable reduction plate = Ø F3

Side entry hood

9	09 67 009 033
15	09 67 015 033
25	09 67 025 033
37	09 67 037 033
50	09 67 050 033

Please insert digit for screw option

Hexagonal screw, thread 4-40 UNC ▶ 8

Hexagonal screw, thread M3 ▶ 9

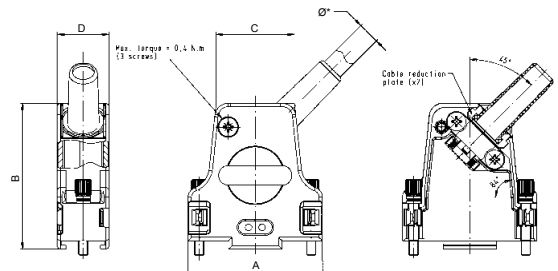



Full metal top entry hoods with premounted threaded inserts

Identification No. of contacts Part number Drawing Dimensions in mm

Top entry hood

9	09 67 009 032
15	09 67 015 032
25	09 67 025 032
37	09 67 037 032
50	09 67 050 032

Please insert digit for premounted insert

- thread 4-40 UNC ▶ 2
- thread M3 ▶ 3

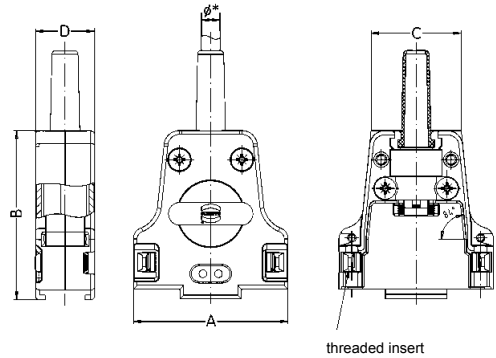

Poles	A	B	C	D	Ø F1		Ø F2	Ø F3
					Min.	Max.		
9	31.6	42.0	20.8	15.2	3.0	9.5	6.5	–
15	40.0	43.5	23.3	15.2	3.0	8.5	6.5	12.5
25	53.7	47.5	31.7	15.2	3.0	8.5	8.0	12.5
37	70.2	50.5	48.2	18.2	3.0	12.0	9.0	15.0
50	67.8	50.5	45.8	18.2	3.0	12.0	9.7	15.0

* Cable diameter without rubber bushing = Ø F1
 Cable diameter with rubber bushing = Ø F2
 Cable diameter without rubber bushing and without cable reduction plate = Ø F3

Locking hook

09 67 002 9031¹⁾

Latch lock bolt

Front mount

- thread 4-40 UNC
- thread M3

09 67 002 9041¹⁾
 09 67 002 9042¹⁾

Rear mount

- thread 4-40 UNC
- thread M3

09 67 002 9032¹⁾
 09 67 002 9040¹⁾

Cable to cable

- thread 4-40 UNC
- thread M3

09 67 002 9044¹⁾
 09 67 002 9045¹⁾

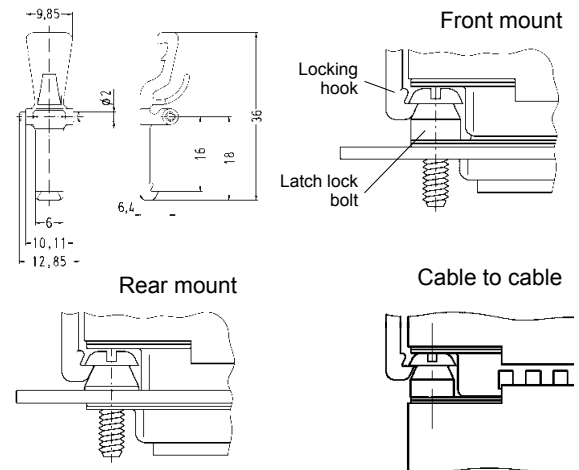

D-Sub

¹⁾ Order 2 for each hood
 Operating temperature for all hoods on this page: -35 °C ... +100 °C



Full metal top and side entry hoods with different screw options

Identification	No. of contacts	Part number	Drawing	Dimensions in mm																																				
40° side entry hood with internal grounding block	9	61 03 001 . 013		<table border="1"> <thead> <tr> <th>No. of contacts</th> <th>A</th> <th>B</th> <th>C</th> <th>D</th> </tr> </thead> <tbody> <tr> <td>9</td> <td>31.0</td> <td>25.0</td> <td>35.0</td> <td>15.0</td> </tr> <tr> <td>15</td> <td>39.3</td> <td>33.3</td> <td>35.0</td> <td>15.0</td> </tr> <tr> <td>25</td> <td>53.0</td> <td>47.0</td> <td>35.0</td> <td>15.0</td> </tr> </tbody> </table>	No. of contacts	A	B	C	D	9	31.0	25.0	35.0	15.0	15	39.3	33.3	35.0	15.0	25	53.0	47.0	35.0	15.0																
	No. of contacts	A			B	C	D																																	
	9	31.0			25.0	35.0	15.0																																	
	15	39.3			33.3	35.0	15.0																																	
25	53.0	47.0	35.0	15.0																																				
15	61 03 001 . 014																																							
25	61 03 001 . 015																																							
without internal grounding block	9	61 03 001 . 013 010																																						
Top/side entry hood with internal grounding block	9	61 03 001 . 010		<table border="1"> <thead> <tr> <th>No. of contacts</th> <th>No. of cable entries</th> <th>A</th> <th>B</th> <th>C</th> <th>D</th> </tr> </thead> <tbody> <tr> <td>9</td> <td>1 (top)</td> <td>31.0</td> <td>25.0</td> <td>38.0</td> <td>15.0</td> </tr> <tr> <td>15</td> <td>1 (top)</td> <td>39.5</td> <td>33.3</td> <td>35.0</td> <td>15.0</td> </tr> <tr> <td>25</td> <td>3</td> <td>53.0</td> <td>47.0</td> <td>43.0</td> <td>15.0</td> </tr> <tr> <td>37</td> <td>3</td> <td>69.5</td> <td>63.5</td> <td>43.0</td> <td>15.0</td> </tr> <tr> <td>50</td> <td>3</td> <td>67.2</td> <td>61.6</td> <td>43.0</td> <td>17.8</td> </tr> </tbody> </table>	No. of contacts	No. of cable entries	A	B	C	D	9	1 (top)	31.0	25.0	38.0	15.0	15	1 (top)	39.5	33.3	35.0	15.0	25	3	53.0	47.0	43.0	15.0	37	3	69.5	63.5	43.0	15.0	50	3	67.2	61.6	43.0	17.8
	No. of contacts	No. of cable entries			A	B	C	D																																
	9	1 (top)			31.0	25.0	38.0	15.0																																
	15	1 (top)			39.5	33.3	35.0	15.0																																
	25	3			53.0	47.0	43.0	15.0																																
	37	3			69.5	63.5	43.0	15.0																																
50	3	67.2	61.6	43.0	17.8																																			
15	61 03 001 . 016																																							
25	61 03 001 . 017 ¹⁾																																							
37	61 03 001 . 018 ¹⁾																																							
50	61 03 001 . 019 ¹⁾																																							
without internal grounding block	9	61 03 001 . 010 010																																						
Please insert digit for screw option																																								
	Knurled screw, thread 4-40 UNC	▶ 0																																						
	Hexagonal screw, thread M3 with captive washer	▶ 1																																						
	Hexagonal screw, thread 4-40 UNC with captive washer	▶ 2																																						
	Knurled screw, thread M3	▶ 3																																						

¹⁾ Part number contains two blanking pieces
Operating temperature for all hoods on this page: -20 °C ... +90 °C

Accessories see page 05.162



Full metal top and side entry hoods with different screw options

Identification No. of contacts Part number Drawing Dimensions in mm

5° top entry hood with 3 cable entries

with internal grounding block

37 61 03 001 . 118

50 61 03 001 . 119

without internal grounding block

37 61 03 001 . 118 010

50 61 03 001 . 119 010

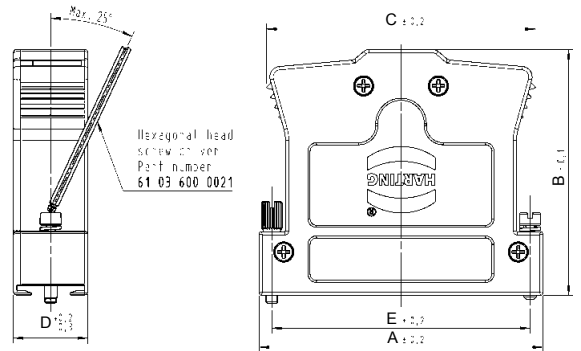

No. of contacts	A	B	C	D	E
37	69.5	52.0	58.2	14.8	63.5
50	67.1	58.0	63.6	17.6	61.1

Please insert digit for screw option

- Knurled screw, thread 4-40 UNC ▶ 0
- Hexagonal screw, thread M3 with captive washer ▶ 1
- Hexagonal screw, thread 4-40 UNC with captive washer ▶ 2
- Knurled screw, thread M3 ▶ 3

Top entry hood for InduCom 9

Hexagonal screw, thread 4-40 UNC

9 66 67 009 0346

Hexagonal screw, thread M3

9 66 67 009 0347

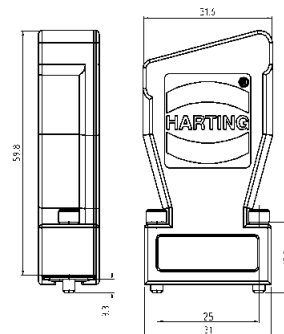

2 cable entries

Connector hoods for spring or slide locking

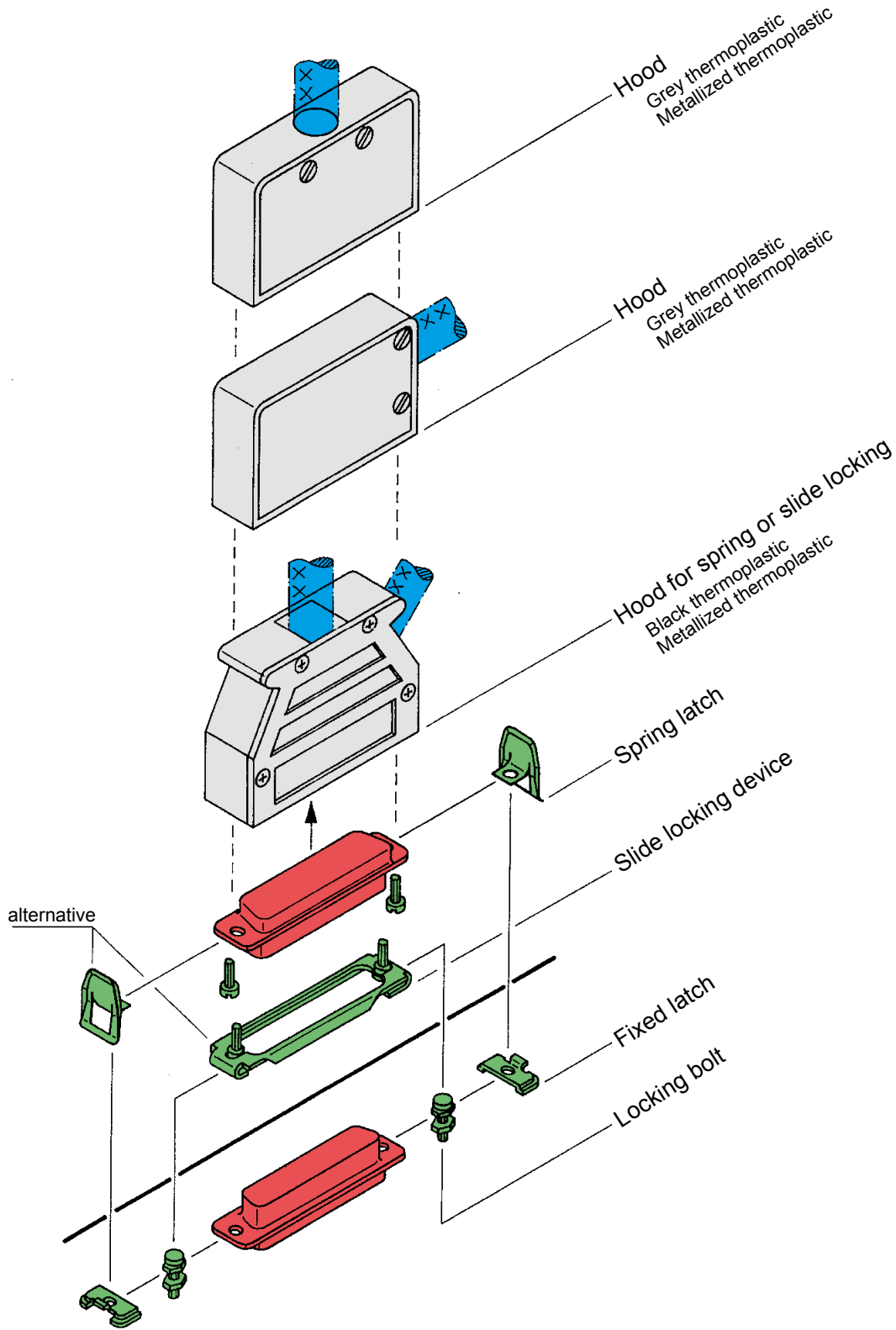



Thermoplastic top and side entry hoods for spring or slide locking

Identification	No. of contacts	Part number		Drawing	Dimensions in mm																																																								
Top entry hood 9-37 way for packaging density of 3 TE (15.24 mm)	9	Thermoplastic grey ²⁾	Thermoplastic metallized ³⁾		<table border="1"> <thead> <tr> <th></th> <th>a</th> <th>b₁</th> <th>b₂</th> <th>c</th> <th>d</th> <th colspan="2">e</th> </tr> <tr> <th></th> <th></th> <th></th> <th></th> <th></th> <th></th> <th>min.</th> <th>max.</th> </tr> </thead> <tbody> <tr> <td>9</td> <td>31.0</td> <td>23</td> <td>28</td> <td>12.8</td> <td>10</td> <td>5.75</td> <td>9.0</td> </tr> <tr> <td>15</td> <td>39.4</td> <td>28</td> <td>28</td> <td>12.8</td> <td>10</td> <td>5.75</td> <td>9.0</td> </tr> <tr> <td>25</td> <td>53.3</td> <td>34</td> <td>34</td> <td>12.8</td> <td>14</td> <td>5.75</td> <td>9.0</td> </tr> <tr> <td>37</td> <td>69.7</td> <td>43</td> <td>43</td> <td>12.8</td> <td>20</td> <td>5.75</td> <td>9.0</td> </tr> <tr> <td>50</td> <td>67.1</td> <td>41</td> <td>41</td> <td>15.8</td> <td>20</td> <td>5.75</td> <td>11.6</td> </tr> </tbody> </table>		a	b ₁	b ₂	c	d	e								min.	max.	9	31.0	23	28	12.8	10	5.75	9.0	15	39.4	28	28	12.8	10	5.75	9.0	25	53.3	34	34	12.8	14	5.75	9.0	37	69.7	43	43	12.8	20	5.75	9.0	50	67.1	41	41	15.8	20	5.75	11.6
		a	b ₁			b ₂	c	d	e																																																				
									min.	max.																																																			
	9	31.0	23			28	12.8	10	5.75	9.0																																																			
	15	39.4	28			28	12.8	10	5.75	9.0																																																			
25	53.3	34	34	12.8	14	5.75	9.0																																																						
37	69.7	43	43	12.8	20	5.75	9.0																																																						
50	67.1	41	41	15.8	20	5.75	11.6																																																						
15	09 67 015 0411	09 67 015 0413																																																											
25	09 67 025 0411	09 67 025 0413																																																											
37	09 67 037 0411	09 67 037 0413																																																											
50	09 67 050 0411	09 67 050 0413																																																											
Side entry hood 9-37 way for packaging density of 3 TE (15.24 mm)	9	Thermoplastic grey ²⁾	Thermoplastic metallized ³⁾																																																										
	15	09 67 015 0511	09 67 015 0513																																																										
	25	09 67 025 0511	09 67 025 0513																																																										
	37	09 67 037 0511	09 67 037 0513																																																										
	50	09 67 050 0511	09 67 050 0513																																																										
Top and side entry hood¹⁾	9	Thermoplastic black ⁴⁾	Thermoplastic metallized ⁴⁾		<table border="1"> <thead> <tr> <th></th> <th>a</th> <th>c</th> <th>d</th> <th colspan="2">e</th> </tr> <tr> <th></th> <th></th> <th></th> <th></th> <th>min.</th> <th>max.</th> </tr> </thead> <tbody> <tr> <td>9</td> <td>31.0</td> <td>15.4</td> <td>7</td> <td>1.7</td> <td>7.5</td> </tr> <tr> <td>15</td> <td>39.4</td> <td>15.4</td> <td>7</td> <td>1.7</td> <td>8.0</td> </tr> <tr> <td>25</td> <td>53.2</td> <td>15.4</td> <td>9</td> <td>1.5</td> <td>8.0</td> </tr> <tr> <td>37</td> <td>69.5</td> <td>15.4</td> <td>9</td> <td>1.5</td> <td>8.0</td> </tr> <tr> <td>50</td> <td>67.0</td> <td>17.9</td> <td>9</td> <td>1.5</td> <td>8.0</td> </tr> </tbody> </table>		a	c	d	e						min.	max.	9	31.0	15.4	7	1.7	7.5	15	39.4	15.4	7	1.7	8.0	25	53.2	15.4	9	1.5	8.0	37	69.5	15.4	9	1.5	8.0	50	67.0	17.9	9	1.5	8.0														
		a	c			d	e																																																						
							min.	max.																																																					
	9	31.0	15.4			7	1.7	7.5																																																					
	15	39.4	15.4			7	1.7	8.0																																																					
25	53.2	15.4	9	1.5	8.0																																																								
37	69.5	15.4	9	1.5	8.0																																																								
50	67.0	17.9	9	1.5	8.0																																																								
15	09 67 015 0452	09 67 015 0453																																																											
25	09 67 025 0452	09 67 025 0453																																																											
37	09 67 037 0452	09 67 037 0453																																																											
50	09 67 050 0452	09 67 050 0453																																																											

¹⁾ 9-poles is only side entry

²⁾ Operating temperature: -55 °C ... +120 °C

³⁾ Operating temperature: -35 °C ... +60 °C

⁴⁾ Operating temperature: -20 °C ... +90 °C

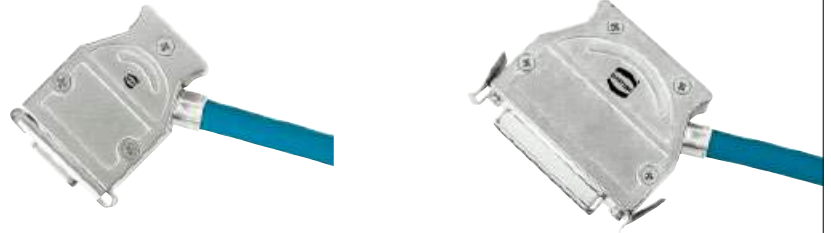

Full metal top and side entry hoods for spring or slide locking

Identification	No. of contacts	Part number	Drawing	Dimensions in mm
----------------	-----------------	-------------	---------	------------------

Top/side entry hood with spring/slide locking

9	61 03 001 0022 ¹⁾
15	61 03 001 0011 ²⁾
25	61 03 001 0012 ²⁾
37	61 03 001 0021 ²⁾
50	61 03 001 0020 ²⁾

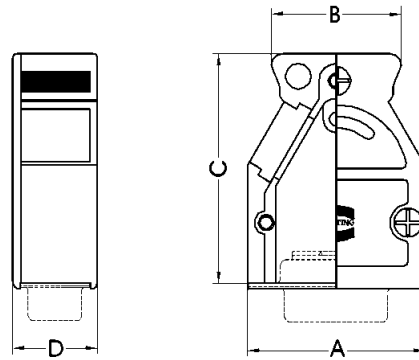

No. of contacts	No. of cable entries	A	B	C	D
9	2	31.0	22.6	40.0	14.8
15	3	39.0	30.6	40.0	14.8
25	3	53.0	42.6	40.0	14.8
37	3	69.5	59.2	40.0	14.8
50	3	67.0	55.0	40.0	17.6

Accessories for spring or slide locking hoods

Identification	No. of contacts	Part number	Drawing	Dimensions in mm																														
Spring latch	9-50	corrosion resistant steel 09 67 000 9907 ¹⁾																																
Fixed latch ²⁾	9-37 50	corrosion resistant steel 09 67 001 9971 ¹⁾ 09 67 001 9972 ¹⁾																																
Slide locking device	9 15 25 37 50	corrosion resistant steel 09 67 000 9914 09 67 000 9915 09 67 000 9916 09 67 000 9917 09 67 000 9918	 <table border="1"> <thead> <tr> <th></th> <th>a</th> <th>b</th> <th>c</th> <th>d</th> </tr> </thead> <tbody> <tr> <td>9</td> <td>35.0</td> <td>25.0</td> <td>11.7</td> <td>8.6</td> </tr> <tr> <td>15</td> <td>43.3</td> <td>33.3</td> <td>11.5</td> <td>8.6</td> </tr> <tr> <td>25</td> <td>57.0</td> <td>47.0</td> <td>11.7</td> <td>8.6</td> </tr> <tr> <td>37</td> <td>74.3</td> <td>63.5</td> <td>11.7</td> <td>8.6</td> </tr> <tr> <td>50</td> <td>72.0</td> <td>61.1</td> <td>14.7</td> <td>11.2</td> </tr> </tbody> </table>		a	b	c	d	9	35.0	25.0	11.7	8.6	15	43.3	33.3	11.5	8.6	25	57.0	47.0	11.7	8.6	37	74.3	63.5	11.7	8.6	50	72.0	61.1	14.7	11.2	
	a	b	c	d																														
9	35.0	25.0	11.7	8.6																														
15	43.3	33.3	11.5	8.6																														
25	57.0	47.0	11.7	8.6																														
37	74.3	63.5	11.7	8.6																														
50	72.0	61.1	14.7	11.2																														
Locking bolt	9-50	tinned 09 67 001 9973 ¹⁾																																

¹⁾ Order 2 for each connector

²⁾ Screws are not supplied with a fixed latch

Accessories – coding system

Coding system

Example of application

Cable side:
female coding system
with 9 pole female cable connector
and InduCom hood
61 03 001 x010 123
(see next page).

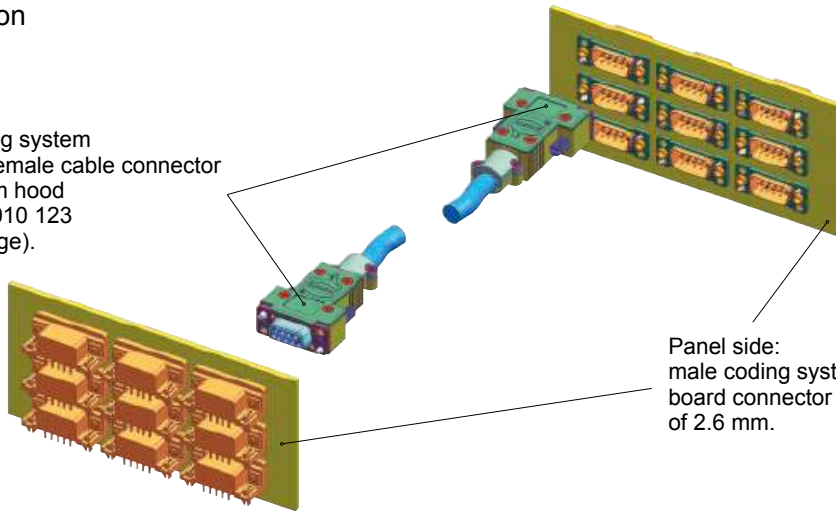

Panel side:
male coding system with 9 pole male
board connector and a board thickness
of 2.6 mm.

Exploded view panel side

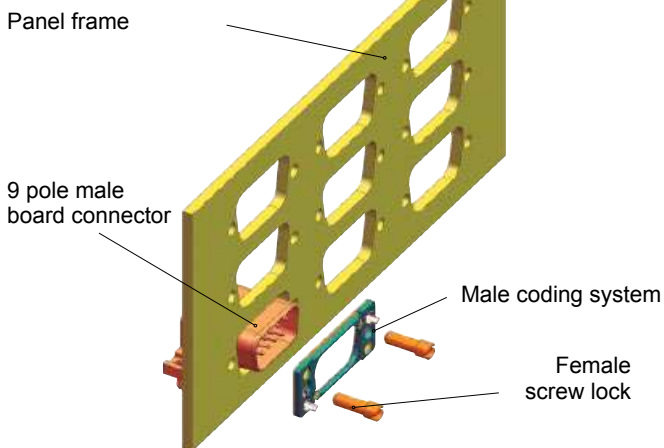

Exploded view cable side

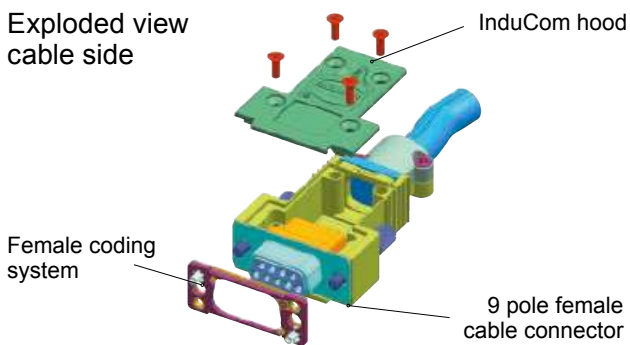

Coding key details

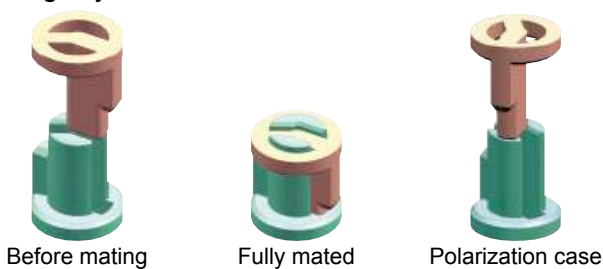

Standard coding combinations

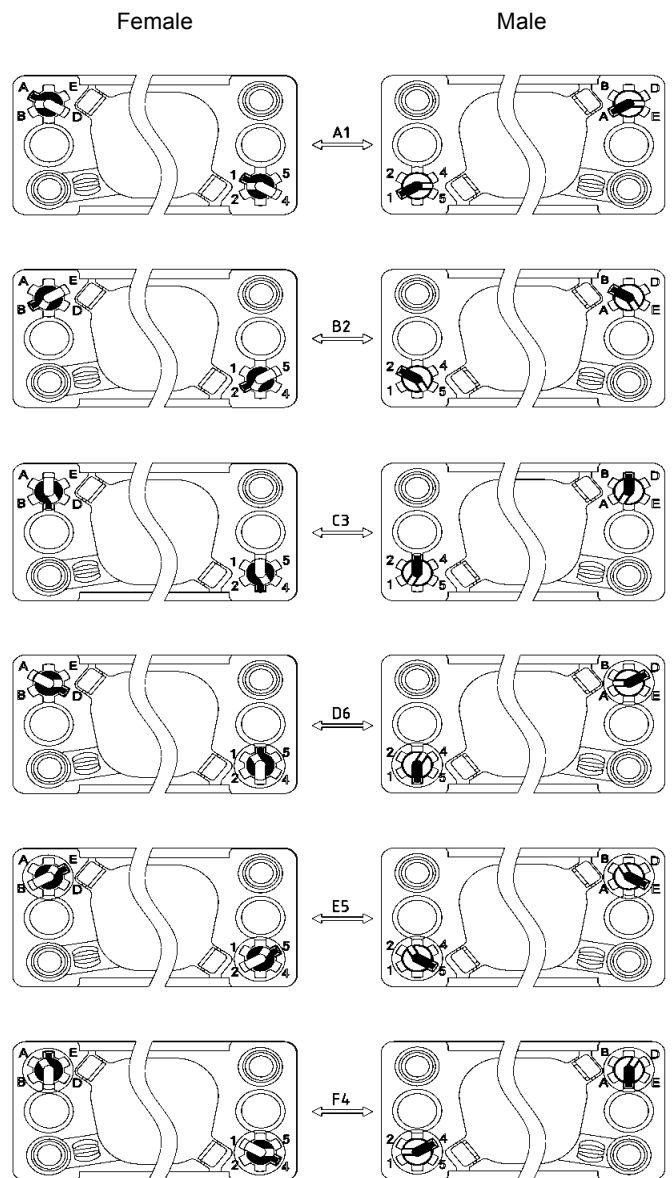

D-Sub

Accessories – coding system

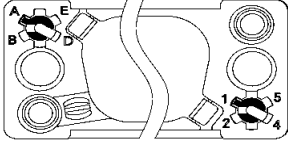
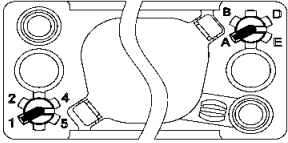
Identification	Part number	Panel thickness	Dimensions in mm																																				
Coding¹⁾																																							
Female	09 67 002 9121 xx 1 09 67 002 9121 xx 2 09 67 002 9121 xx 3 09 67 002 9121 xx 4	2.40 - 2.60 mm ³⁾ 2.00 - 2.40 mm 1.20 - 2.00 mm 0.80 - 1.20 mm																																					
Male	09 67 002 9122 xx 1 09 67 002 9122 xx 2 09 67 002 9122 xx 3 09 67 002 9122 xx 4	2.40 - 2.60 mm ³⁾ 2.00 - 2.40 mm 1.20 - 2.00 mm 0.80 - 1.20 mm																																					
Insert digits for coding configuration, e. g. "C3"		36 coding configurations ²⁾	<table border="1"> <tr><td>A1</td><td>B1</td><td>C1</td><td>D1</td><td>E1</td><td>F1</td></tr> <tr><td>A2</td><td>B2</td><td>C2</td><td>D2</td><td>E2</td><td>F2</td></tr> <tr><td>A3</td><td>B3</td><td>C3</td><td>D3</td><td>E3</td><td>F3</td></tr> <tr><td>A4</td><td>B4</td><td>C4</td><td>D4</td><td>E4</td><td>F4</td></tr> <tr><td>A5</td><td>B5</td><td>C5</td><td>D5</td><td>E5</td><td>F5</td></tr> <tr><td>A6</td><td>B6</td><td>C6</td><td>D6</td><td>E6</td><td>F6</td></tr> </table>	A1	B1	C1	D1	E1	F1	A2	B2	C2	D2	E2	F2	A3	B3	C3	D3	E3	F3	A4	B4	C4	D4	E4	F4	A5	B5	C5	D5	E5	F5	A6	B6	C6	D6	E6	F6
A1	B1	C1	D1	E1	F1																																		
A2	B2	C2	D2	E2	F2																																		
A3	B3	C3	D3	E3	F3																																		
A4	B4	C4	D4	E4	F4																																		
A5	B5	C5	D5	E5	F5																																		
A6	B6	C6	D6	E6	F6																																		
Depending on the panel thickness the suitable coding needs to be selected.																																							

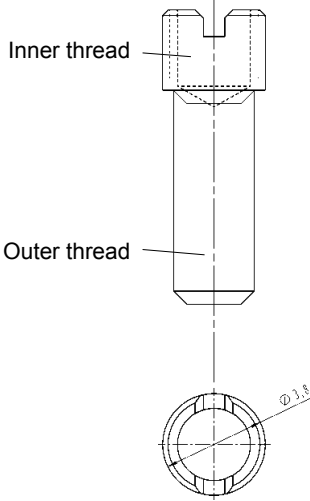
Female screw lock for angled PCB connectors ³⁾	Part number	Panel thickness	Dimensions in mm												
<table border="1"> <thead> <tr><th colspan="2">Thread</th></tr> <tr><th>inner</th><th>outer</th></tr> </thead> <tbody> <tr><td>4 - 40 UNC</td><td>4 - 40 UNC</td></tr> <tr><td>4 - 40 UNC</td><td>M3</td></tr> <tr><td>M3</td><td>4 - 40 UNC</td></tr> <tr><td>M3</td><td>M3</td></tr> </tbody> </table>	Thread		inner	outer	4 - 40 UNC	4 - 40 UNC	4 - 40 UNC	M3	M3	4 - 40 UNC	M3	M3	09 67 002 9123 ⁴⁾ 09 67 002 9124 09 67 002 9125 09 67 002 9126	2.00 - 2.60 mm	
Thread															
inner	outer														
4 - 40 UNC	4 - 40 UNC														
4 - 40 UNC	M3														
M3	4 - 40 UNC														
M3	M3														
<table border="1"> <tbody> <tr><td>4 - 40 UNC</td><td>4 - 40 UNC</td></tr> <tr><td>4 - 40 UNC</td><td>M3</td></tr> <tr><td>M3</td><td>4 - 40 UNC</td></tr> <tr><td>M3</td><td>M3</td></tr> </tbody> </table>	4 - 40 UNC	4 - 40 UNC	4 - 40 UNC	M3	M3	4 - 40 UNC	M3	M3	09 67 002 9129 09 67 002 9130 09 67 002 9131 09 67 002 9132	1.20 - 2.00 mm					
4 - 40 UNC	4 - 40 UNC														
4 - 40 UNC	M3														
M3	4 - 40 UNC														
M3	M3														
<table border="1"> <tbody> <tr><td>4 - 40 UNC</td><td>4 - 40 UNC</td></tr> <tr><td>4 - 40 UNC</td><td>M3</td></tr> <tr><td>M3</td><td>4 - 40 UNC</td></tr> <tr><td>M3</td><td>M3</td></tr> </tbody> </table>	4 - 40 UNC	4 - 40 UNC	4 - 40 UNC	M3	M3	4 - 40 UNC	M3	M3	09 67 002 9133 09 67 002 9134 09 67 002 9135 09 67 002 9136	0.80 - 1.20 mm					
4 - 40 UNC	4 - 40 UNC														
4 - 40 UNC	M3														
M3	4 - 40 UNC														
M3	M3														

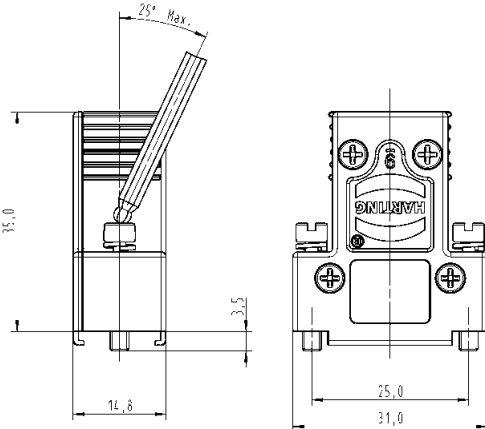
9 pole InduCom top entry hood for coding	Part number	Dimensions in mm
Please insert digit for screw option Hexagonal screw, thread M3 with captive washer ▶ 1 Hexagonal screw, thread 4-40 UNC with captive washer ▶ 2	61 03 001 . 010 123	

1) MOQ = 50 pieces
 2) Stock items (standard versions) in bold type
 3) Female screw lock for straight PCB connectors on request
 4) Standard versions

D-Sub

Accessories for full metal hoods

Identification	Part number		Drawing	Dimensions in mm																																								
	for 9-37-pole D-Sub	for 50-pole D-Sub																																										
Cable clamp Cable-Ø appr. 5- 7 mm Cable-Ø appr. 7-10 mm Cable-Ø appr. 9-12 mm Cable-Ø appr. 11-14 mm Cable-Ø appr. 14-16 mm	61 03 000 0141 61 03 000 0044 61 03 000 0143 61 03 000 0148	61 03 000 0145 61 03 000 0147																																										
Crimp flange	61 03 000 0062 61 03 000 0063 61 03 000 0064 61 03 000 0065 61 03 000 0066 61 03 000 0166 61 03 000 0067 61 03 000 0068 61 03 000 0069 61 03 000 0070 61 03 000 0071 61 03 000 0165 61 03 000 0072	61 03 000 5062 61 03 000 5063 61 03 000 5064 61 03 000 5065 61 03 000 5066 61 03 000 5166 61 03 000 5067 61 03 000 5068 61 03 000 5069 61 03 000 5070 61 03 000 5071 61 03 000 5165 61 03 000 5072	<table border="1"> <thead> <tr> <th>D1</th> <th>D2</th> </tr> </thead> <tbody> <tr><td>3.0</td><td>4.0</td></tr> <tr><td>3.5</td><td>4.5</td></tr> <tr><td>4.0</td><td>5.0</td></tr> <tr><td>4.5</td><td>5.5</td></tr> <tr><td>5.0</td><td>6.0</td></tr> <tr><td>5.5</td><td>6.5</td></tr> <tr><td>6.0</td><td>7.0</td></tr> <tr><td>6.5</td><td>7.5</td></tr> <tr><td>7.0</td><td>8.0</td></tr> <tr><td>7.5</td><td>8.5</td></tr> <tr><td>8.0</td><td>9.0</td></tr> <tr><td>8.5</td><td>9.5</td></tr> <tr><td>9.0</td><td>10.0</td></tr> </tbody> </table>	D1	D2	3.0	4.0	3.5	4.5	4.0	5.0	4.5	5.5	5.0	6.0	5.5	6.5	6.0	7.0	6.5	7.5	7.0	8.0	7.5	8.5	8.0	9.0	8.5	9.5	9.0	10.0													
D1	D2																																											
3.0	4.0																																											
3.5	4.5																																											
4.0	5.0																																											
4.5	5.5																																											
5.0	6.0																																											
5.5	6.5																																											
6.0	7.0																																											
6.5	7.5																																											
7.0	8.0																																											
7.5	8.5																																											
8.0	9.0																																											
8.5	9.5																																											
9.0	10.0																																											
Crimp ferrule	61 03 000 0045 61 03 000 0046 61 03 000 0047 61 03 000 0048 61 03 000 0049 61 03 000 0050 61 03 000 0051 61 03 000 0052 61 03 000 0053 61 03 000 0054 61 03 000 0055 61 03 000 0056 61 03 000 0057 61 03 000 0058 61 03 000 0142 61 03 000 0059 61 03 000 0127 61 03 000 0060 61 03 000 0061		<table border="1"> <thead> <tr> <th>D3</th> <th>D4</th> </tr> </thead> <tbody> <tr><td>5.0</td><td>6.0</td></tr> <tr><td>5.5</td><td>6.5</td></tr> <tr><td>6.0</td><td>7.0</td></tr> <tr><td>6.5</td><td>7.5</td></tr> <tr><td>7.0</td><td>8.0</td></tr> <tr><td>7.5</td><td>8.5</td></tr> <tr><td>8.0</td><td>9.0</td></tr> <tr><td>8.5</td><td>9.5</td></tr> <tr><td>9.0</td><td>10.0</td></tr> <tr><td>9.5</td><td>10.5</td></tr> <tr><td>10.0</td><td>11.0</td></tr> <tr><td>10.5</td><td>11.5</td></tr> <tr><td>11.0</td><td>12.0</td></tr> <tr><td>11.5</td><td>12.5</td></tr> <tr><td>12.0</td><td>13.0</td></tr> <tr><td>12.5</td><td>13.5</td></tr> <tr><td>13.0</td><td>14.0</td></tr> <tr><td>13.7</td><td>15.0</td></tr> <tr><td>14.0</td><td>15.0</td></tr> </tbody> </table>	D3	D4	5.0	6.0	5.5	6.5	6.0	7.0	6.5	7.5	7.0	8.0	7.5	8.5	8.0	9.0	8.5	9.5	9.0	10.0	9.5	10.5	10.0	11.0	10.5	11.5	11.0	12.0	11.5	12.5	12.0	13.0	12.5	13.5	13.0	14.0	13.7	15.0	14.0	15.0	
D3	D4																																											
5.0	6.0																																											
5.5	6.5																																											
6.0	7.0																																											
6.5	7.5																																											
7.0	8.0																																											
7.5	8.5																																											
8.0	9.0																																											
8.5	9.5																																											
9.0	10.0																																											
9.5	10.5																																											
10.0	11.0																																											
10.5	11.5																																											
11.0	12.0																																											
11.5	12.5																																											
12.0	13.0																																											
12.5	13.5																																											
13.0	14.0																																											
13.7	15.0																																											
14.0	15.0																																											
Blanking piece for hoods	61 03 000 0042	61 03 000 0041																																										
Hexagonal screw thread 4-40 UNC x 17.5-8.8 with captive washer thread M3 x 17.5-8.8 with captive washer	09 67 002 9020 09 67 002 9019																																											
Knurled screw thread 4-40 UNC thread M3	09 67 002 9018 09 67 002 9017																																											

D-Sub

Crimp flange termination instruction

1. Strip the cable sheath to the correct length (approx. 35 to 40 mm, depending on interface type).
2. Place the crimp ferrule over the cable sheath. Bend the outer screen backwards over the cable sheath. Cut screen approx. 2 mm from the end of the cable sheath.
3. Place the crimp flange over the wires covered by the remaining foil shield. Push and twist the crimp flange under the outer screen and cable sheath until the end of the cable sheath touches the crimp flange. HARTING has developed a special tool for optimised installation of the shielding over the crimp flange, part number 61 03 600 0017.
4. Move the crimp ferrule back onto the crimp flange and crimp the two parts together with the special service crimp tool part number 61 03 600 0020. For an optimised crimp process the tool should be positioned as close as possible to the crimp flange shoulder.
5. Cut off the internal screen foil and push the crimp flange inside the metal hood.

HARTING offers to test and define the best crimp flange and ferrule combination for customer specific cables.

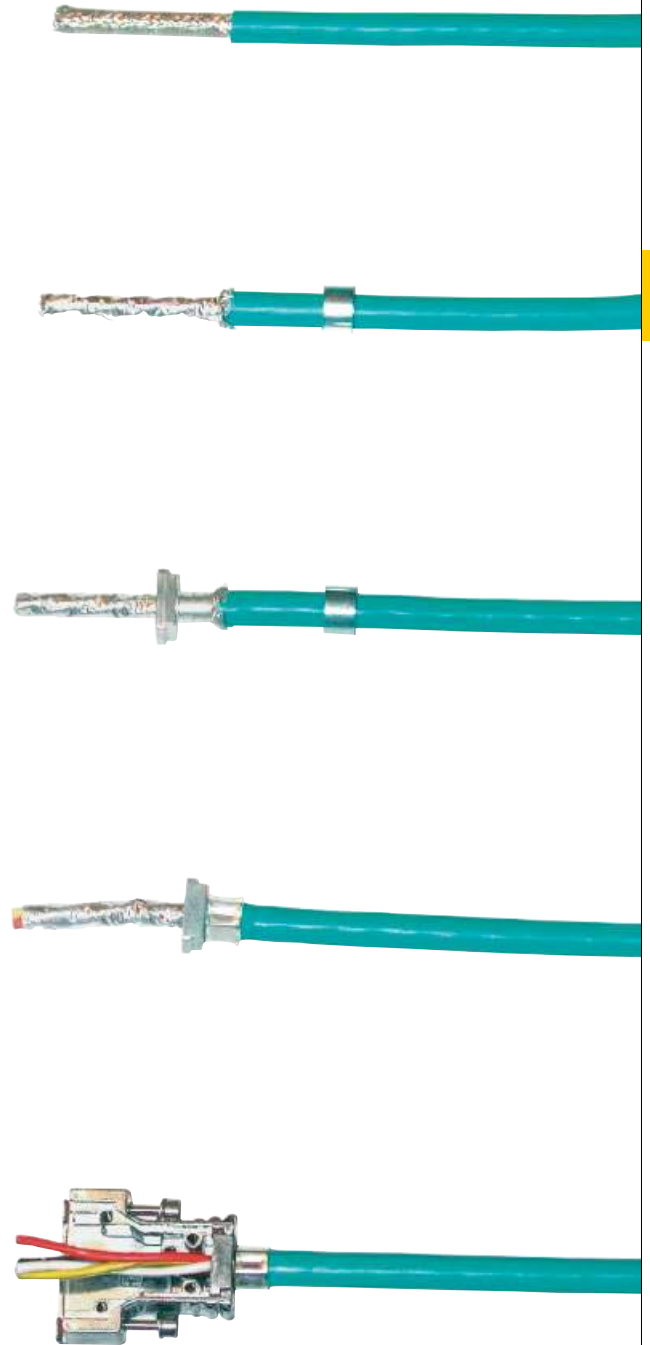

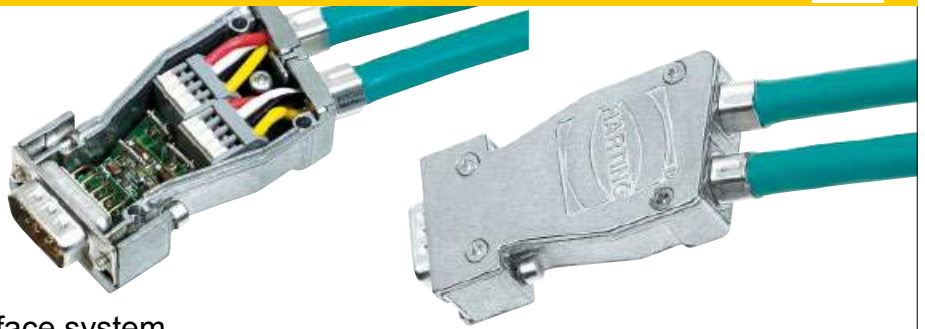

InduCom 9 – Industrial bus interface system

Identification

Part number

General information

MVB Interface

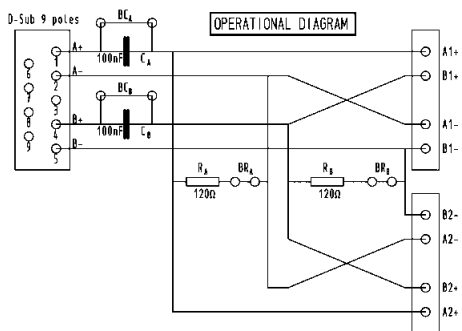
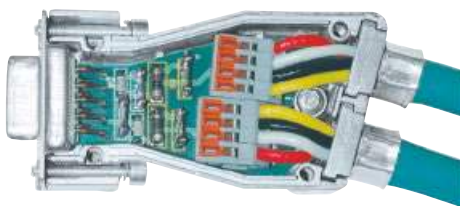

66 63 009 5013

MVB backbone interface set

The Multifunctional Vehicle Bus (MVB) backbone interface is specially designed for communication cables in Train Control Networks (TCN). With this interface it is possible to realise a T-bus structure with MVB-cable with which you can disconnect the bus interface from the control unit without any interruption of the complete bus communication. On the PCB you will have load resistors and test capacitors which can be activated with solder bridges. The wires are terminated with the proven vibration resistant cage clamp technology.*

Components of the MVB interface set:

- 1 metal housing with 2 cable entries
- 2 hexagonal screws with UNC 4-40 threads
- 1 PCB with 9 way D-Sub male connector and cage clamps
- 2 crimp flanges for the MVB cable
- 2 crimp ferrules for the MVB cable
- 1 blanking piece

WTB Interface

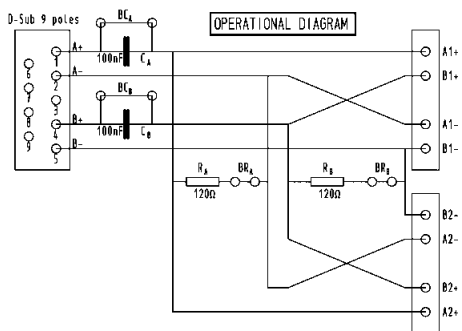
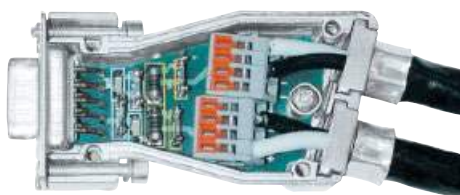

66 63 009 5014

WTB backbone interface set

The Wired Train Bus (WTB) backbone interface is specially designed for backbone cables in Train Control Networks (TCN). With this interface it is possible to realise a T-bus structure with WTB-cable with which you can disconnect the bus interface from the control unit without any interruption of the complete bus communication. On the PCB you will have load resistors and test capacitors which can be activated with solder bridges. The wires are terminated with the proven vibration resistant cage clamp technology.*

Components of the MVB interface set:

- 1 metal housing with 2 cable entries
- 2 hexagonal screws with UNC 4-40 threads
- 1 PCB with 9 way D-Sub male connector and cage clamps
- 2 crimp flanges for the WTB cable
- 2 crimp ferrules for the WTB cable
- 1 blanking piece

D-Sub



InduCom 9 – Industrial bus interface system

Identification

Part number

General information

CAN Interface



66 63 009 6016

The Controller Area Network (CAN)-Interface is specially designed for usage in trains. With this interface it is possible to realise a T-bus structure with which you can disconnect the bus interface from the control unit without any interruption of the complete bus communication. On the PCB you will have a load resistor which can be activated with the switch.*

Components of the interface set:

- 1 metal housing with 2 cable entries
- 2 hexagonal screws with UNC 4-40 threads
- 1 PCB with 9 way D-Sub female connector and 2 cage clamps
- 1 blanking piece
- 2 crimp flanges
- 2 crimp ferrules

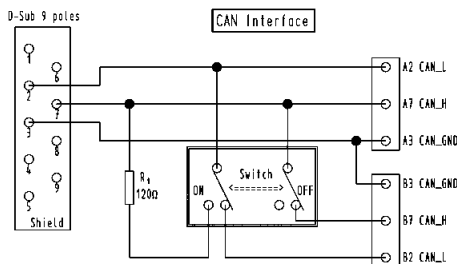

Profibus Interface

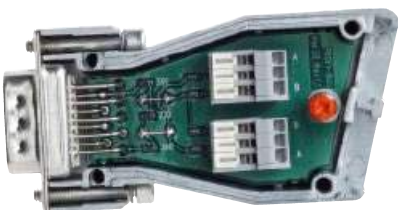

66 63 009 6004

The Profibus Interface is specially designed for usage in trains and in challenging engineering applications.

On the PCB you will have SMD parts which can be activated with solder bridges.

The wires are assembled with the proven vibration resistant cage clamp technology.*

Components of the interface set:

- 1 metal housing with 2 cable entries
- 2 hexagonal screws with UNC 4-40 threads
- 1 PCB with 9 way D-Sub female connector and 2 cage clamps
- 1 blanking piece

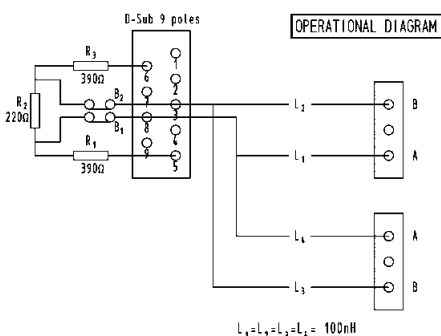

Further bus PCBs on request

* To check compatibility with cable types and manufacturers, please contact your local HARTING representative.



InduCom 9 – Industrial bus interface system

Identification

Part number

General information

FIP Interface middle of the line

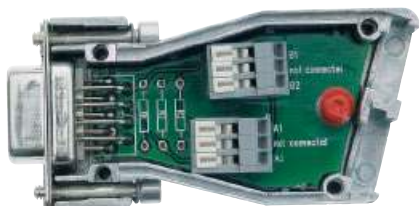

66 63 009 5017

The FIP (Factory Installation Protocol) Interface is specially designed for applications in trains. It is connected via the D-Sub. The wires are assembled with the proven vibration resistant cage clamp technology.*

Components of the interface set:

- 1 metal housing with 2 cable entries
- 2 hexagonal screws with UNC 4-40 threads
- 1 pcb with 9 way D-Sub female connector and cage clamps

FIP interface

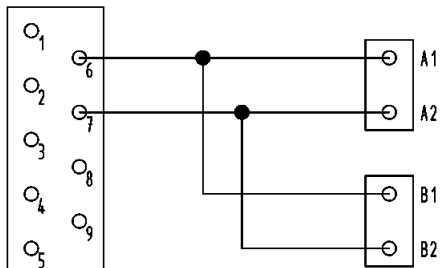

FIP Interface end of the line



66 63 009 5018

The FIP (Factory Installation Protocol) Interface is specially designed for applications in trains. It is connected via the D-Sub. On the pcb you will have load resistors. The wires are assembled with the proven vibration resistant cage clamp technology.*

Components of the interface set:

- 1 metal housing with 2 cable entries
- 2 hexagonal screws with UNC 4-40 threads
- 1 pcb with 9 way D-Sub female connector and cage clamps
- 1 blanking piece

FIP interface

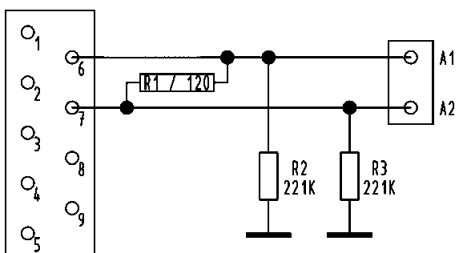

Accessories

Identification	No. of contacts	Part number	Drawing	Dimensions in mm
Female screw locks without nut	9-50	09 67 000 9972 ¹⁾		4-40 UNC M3
	9-50	09 67 000 9974 ¹⁾		4-40 UNC
	9-50	09 67 001 9976 ¹⁾		M3 M3
Thread UNC/UNC	9-50	09 67 001 9941 ¹⁾		4-40 UNC M3
Thread UNC/M3	9-50	09 67 001 9954 ¹⁾		4-40 UNC
Thread M3/UNC	9-50	09 67 001 9974 ¹⁾		M3 M3
Thread M3/M3	9-50	09 67 001 9941 ¹⁾		4-40 UNC
Thread UNC/UNC	9-50	09 67 001 9974 ¹⁾		M3
Thread UNC/M3	9-50	09 67 001 9954 ¹⁾		M3
for press-in connectors with grounding-pins or straight solder with grounding-clips.	9-50	09 66 000 9972 ¹⁾		4-40 UNC M3
Thread UNC/UNC	9-50	09 66 000 9974 ¹⁾²⁾		4-40 UNC
Thread UNC/M3	9-50	09 66 000 9974 ¹⁾²⁾		M3
with captive washer	9-50	09 67 001 9957 ¹⁾		

D-Sub

1) Order 2 for each connector
 2) M3 inner thread available on request

Accessories

Identification	No. of contacts	Part number	Drawing	Dimensions in mm
Female screw locks with nut Thread UNC/UNC Thread UNC/M3 Thread UNC/UNC	9-50 9-50 9-50	09 67 000 9922 ¹⁾ 09 67 000 9924 ¹⁾ 09 67 000 9973 ¹⁾		
Male screw locks for use without hood	9-37 50	09 67 001 9969 ¹⁾ 09 67 001 9970 ¹⁾		
Hex extender Thread 4-40 UNC Thread M3	9-50 9-50	09 67 001 9985 09 67 002 9120		
U-Clip with thread 4-40 UNC	9-50	09 67 001 9928 ¹⁾		
U-Clip with thread 4-40 UNC and screw-lock	9-50	09 67 002 9030 ¹⁾		

D-Sub

¹⁾ Order 2 for each connector

Accessories

Identification	No. of contacts	Part number	Drawing	Dimensions in mm																															
Dust cap black thermoplastic for male connector	9	09 67 009 0611			<table border="1"> <thead> <tr> <th></th> <th>A</th> <th>B</th> </tr> </thead> <tbody> <tr> <td>9</td> <td>17.0</td> <td>22.40</td> </tr> <tr> <td>15</td> <td>25.3</td> <td>30.80</td> </tr> <tr> <td>25</td> <td>38.9</td> <td>44.40</td> </tr> <tr> <td>37</td> <td>55.4</td> <td>60.75</td> </tr> </tbody> </table>		A	B	9	17.0	22.40	15	25.3	30.80	25	38.9	44.40	37	55.4	60.75															
		A			B																														
	9	17.0			22.40																														
	15	25.3			30.80																														
	25	38.9	44.40																																
	37	55.4	60.75																																
	15	09 67 015 0611																																	
	25	09 67 025 0611																																	
	37	09 67 037 0611																																	
	9	09 67 009 0711			<table border="1"> <thead> <tr> <th></th> <th>A</th> <th>B</th> </tr> </thead> <tbody> <tr> <td>9</td> <td>16.0</td> <td>22.5</td> </tr> <tr> <td>15</td> <td>24.4</td> <td>31.0</td> </tr> <tr> <td>25</td> <td>37.8</td> <td>44.3</td> </tr> <tr> <td>37</td> <td>54.3</td> <td>60.8</td> </tr> </tbody> </table>		A	B	9	16.0	22.5	15	24.4	31.0	25	37.8	44.3	37	54.3	60.8															
	A	B																																	
9	16.0	22.5																																	
15	24.4	31.0																																	
25	37.8	44.3																																	
37	54.3	60.8																																	
15	09 67 015 0711																																		
25	09 67 025 0711																																		
37	09 67 037 0711																																		
antistatic black thermoplastic for male connector	9	09 67 009 0612			<table border="1"> <thead> <tr> <th></th> <th>A</th> <th>B</th> <th>C</th> <th>D</th> </tr> </thead> <tbody> <tr> <td>9</td> <td>17.7</td> <td>21.8</td> <td>13.2</td> <td>9.1</td> </tr> <tr> <td>15</td> <td>26.0</td> <td>30.0</td> <td>13.2</td> <td>9.1</td> </tr> <tr> <td>25</td> <td>40.0</td> <td>44.2</td> <td>13.2</td> <td>9.1</td> </tr> <tr> <td>37</td> <td>56.4</td> <td>59.8</td> <td>13.2</td> <td>9.1</td> </tr> <tr> <td>50</td> <td>53.9</td> <td>57.8</td> <td>15.9</td> <td>11.7</td> </tr> </tbody> </table>		A	B	C	D	9	17.7	21.8	13.2	9.1	15	26.0	30.0	13.2	9.1	25	40.0	44.2	13.2	9.1	37	56.4	59.8	13.2	9.1	50	53.9	57.8	15.9	11.7
		A			B	C	D																												
	9	17.7			21.8	13.2	9.1																												
	15	26.0			30.0	13.2	9.1																												
	25	40.0			44.2	13.2	9.1																												
	37	56.4	59.8	13.2	9.1																														
	50	53.9	57.8	15.9	11.7																														
	15	09 67 015 0612																																	
	25	09 67 025 0612																																	
	37	09 67 037 0612																																	
50	09 67 050 0612																																		
9	09 67 009 0712			<table border="1"> <thead> <tr> <th></th> <th>A</th> <th>B</th> <th>C</th> <th>D</th> </tr> </thead> <tbody> <tr> <td>9</td> <td>15.9</td> <td>20.0</td> <td>11.8</td> <td>7.8</td> </tr> <tr> <td>15</td> <td>24.4</td> <td>28.5</td> <td>11.8</td> <td>7.8</td> </tr> <tr> <td>25</td> <td>38.3</td> <td>42.3</td> <td>11.8</td> <td>7.8</td> </tr> <tr> <td>37</td> <td>54.7</td> <td>58.8</td> <td>11.8</td> <td>7.8</td> </tr> <tr> <td>50</td> <td>52.6</td> <td>56.2</td> <td>14.5</td> <td>10.5</td> </tr> </tbody> </table>		A	B	C	D	9	15.9	20.0	11.8	7.8	15	24.4	28.5	11.8	7.8	25	38.3	42.3	11.8	7.8	37	54.7	58.8	11.8	7.8	50	52.6	56.2	14.5	10.5	
	A			B	C	D																													
9	15.9			20.0	11.8	7.8																													
15	24.4			28.5	11.8	7.8																													
25	38.3			42.3	11.8	7.8																													
37	54.7	58.8	11.8	7.8																															
50	52.6	56.2	14.5	10.5																															
15	09 67 015 0712																																		
25	09 67 025 0712																																		
37	09 67 037 0712																																		
50	09 67 050 0712																																		
UL 94 V0 grey thermoplastic for male connector	9	09 67 009 0613			<table border="1"> <thead> <tr> <th></th> <th>A</th> <th>B</th> <th>C</th> <th>D</th> </tr> </thead> <tbody> <tr> <td>9</td> <td>17.7</td> <td>21.8</td> <td>13.2</td> <td>9.1</td> </tr> <tr> <td>15</td> <td>26.0</td> <td>30.0</td> <td>13.2</td> <td>9.1</td> </tr> <tr> <td>25</td> <td>40.0</td> <td>44.2</td> <td>13.2</td> <td>9.1</td> </tr> <tr> <td>37</td> <td>56.4</td> <td>59.8</td> <td>13.2</td> <td>9.1</td> </tr> <tr> <td>50</td> <td>53.9</td> <td>57.8</td> <td>15.9</td> <td>11.7</td> </tr> </tbody> </table>		A	B	C	D	9	17.7	21.8	13.2	9.1	15	26.0	30.0	13.2	9.1	25	40.0	44.2	13.2	9.1	37	56.4	59.8	13.2	9.1	50	53.9	57.8	15.9	11.7
		A			B	C	D																												
	9	17.7			21.8	13.2	9.1																												
	15	26.0			30.0	13.2	9.1																												
	25	40.0			44.2	13.2	9.1																												
	37	56.4	59.8	13.2	9.1																														
	50	53.9	57.8	15.9	11.7																														
	15	09 67 015 0613																																	
	25	09 67 025 0613																																	
	37	09 67 037 0613																																	
50	09 67 050 0613																																		
9	09 67 009 0713			<table border="1"> <thead> <tr> <th></th> <th>A</th> <th>B</th> <th>C</th> <th>D</th> </tr> </thead> <tbody> <tr> <td>9</td> <td>15.9</td> <td>20.0</td> <td>11.8</td> <td>7.8</td> </tr> <tr> <td>15</td> <td>24.4</td> <td>28.5</td> <td>11.8</td> <td>7.8</td> </tr> <tr> <td>25</td> <td>38.3</td> <td>42.3</td> <td>11.8</td> <td>7.8</td> </tr> <tr> <td>37</td> <td>54.7</td> <td>58.8</td> <td>11.8</td> <td>7.8</td> </tr> <tr> <td>50</td> <td>52.6</td> <td>56.2</td> <td>14.5</td> <td>10.5</td> </tr> </tbody> </table>		A	B	C	D	9	15.9	20.0	11.8	7.8	15	24.4	28.5	11.8	7.8	25	38.3	42.3	11.8	7.8	37	54.7	58.8	11.8	7.8	50	52.6	56.2	14.5	10.5	
	A			B	C	D																													
9	15.9			20.0	11.8	7.8																													
15	24.4			28.5	11.8	7.8																													
25	38.3			42.3	11.8	7.8																													
37	54.7	58.8	11.8	7.8																															
50	52.6	56.2	14.5	10.5																															
15	09 67 015 0713																																		
25	09 67 025 0713																																		
37	09 67 037 0713																																		
50	09 67 050 0713																																		

Accessories

Identification No. of contacts Part number Drawing Dimensions in mm

Dust cap
metallized
thermoplastic

for male connector

9	09 67 009 0614
15	09 67 015 0614
25	09 67 025 0614
37	09 67 037 0614
50	09 67 050 0614

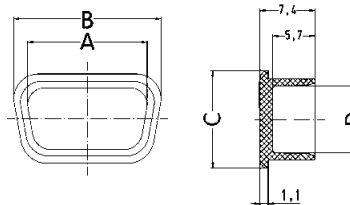

	A	B	C	D
9	17.7	21.8	13.2	9.1
15	26.0	30.0	13.2	9.1
25	40.0	44.2	13.2	9.1
37	56.4	59.8	13.2	9.1
50	53.9	57.8	15.9	11.7

for female connector

9	09 67 009 0714
15	09 67 015 0714
25	09 67 025 0714
37	09 67 037 0714
50	09 67 050 0714

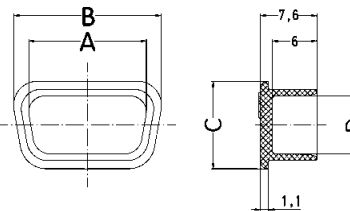

	A	B	C	D
9	15.9	20.0	11.8	7.8
15	24.4	28.5	11.8	7.8
25	38.3	42.3	11.8	7.8
37	54.7	58.8	11.8	7.8
50	52.6	56.2	14.5	10.5

metallized
thermoplastic
with chain

for male connector

9	09 67 009 0615
15	09 67 015 0615
25	09 67 025 0615
37	09 67 037 0615
50	09 67 050 0615

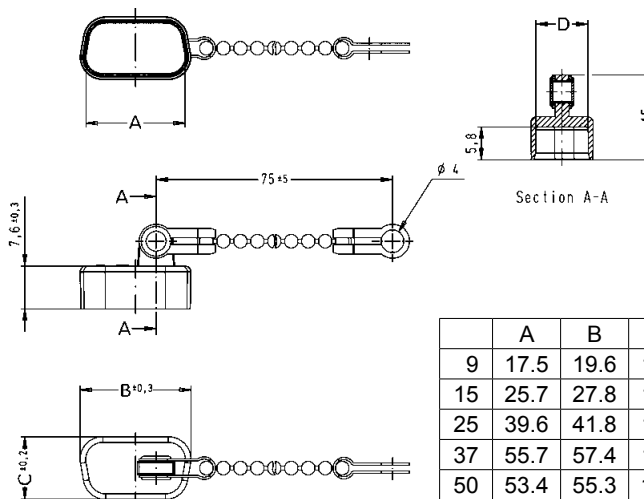

	A	B	C	D
9	17.5	19.6	11.1	9.2
15	25.7	27.8	11.1	9.2
25	39.6	41.8	11.1	9.2
37	55.7	57.4	11.1	9.2
50	53.4	55.3	13.8	11.9

for female connector

9	09 67 009 0715
15	09 67 015 0715
25	09 67 025 0715
37	09 67 037 0715
50	09 67 050 0715

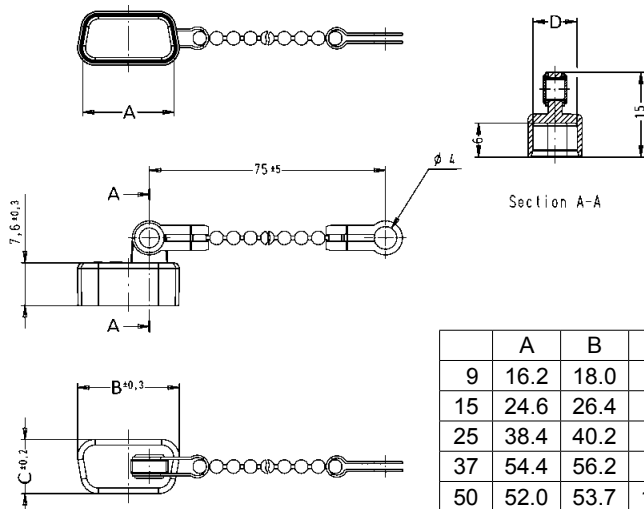

	A	B	C	D
9	16.2	18.0	9.6	7.8
15	24.6	26.4	9.6	7.8
25	38.4	40.2	9.6	7.8
37	54.4	56.2	9.6	7.8
50	52.0	53.7	12.2	10.4

Number of contacts 9, 15, 25, 37, 50
UL recognized

Working current
see current carrying capacity chart
Stamped contacts 6.5 A max.

Test voltage $U_{r.m.s.}$ 1 kV

Clearance and creepage ≥ 1.0 mm

Contact resistance ≤ 10 m Ω
Insulation resistance $\geq 10^{10}$ Ω

Temperature range -55 °C ... +125 °C
The higher temperature limit includes the local ambient and heating effect of the contacts under load

Terminations Recommended PCB through holes

	Signal pin	Grounding pin
--	------------	---------------

Tin-lead plated PCB	Hole	1.15 ^{-0.03}	3.15 \pm 0.025
	Cu	25-75 μ m	25-75 μ m
	Sn	5-15 μ m	4-10 μ m
	Plated hole	0.94-1.09 mm	3.0-3.15 mm

Chemical tin-plated PCB	Hole	1.05 ^{-0.03}	3.15 \pm 0.025
	Cu	25-50 μ m	25-50 μ m
	Sn	0.8-1.0 μ m	0.8-1.0 μ m
	Plated hole	1.00-1.10 mm	3.0-3.15 mm

Au / Ni plated PCB	Hole	1.15 ^{-0.03}	3.15 \pm 0.025
	Cu	25-50 μ m	25-50 μ m
	Ni	3-7 μ m	4-7 μ m
	Au	0.05-0.12 μ m	0.05-0.12 μ m
Plated hole	1.00-1.10 mm	3.0-3.15 mm	

Silver plated PCB	Hole	1.15 ^{-0.03}	3.15 \pm 0.025
	Cu	25-50 μ m	25-50 μ m
	Ag	0.1-0.3 μ m	0.1-0.3 μ m
	Plated hole	1.00-1.10 mm	3.0-3.15 mm

OSP copper plated PCB	Hole	1.15 ^{-0.03}	3.15 \pm 0.025
	Cu	25-50 μ m	25-50 μ m
	Plated hole	1.00-1.10 mm	3.0-3.15 mm

PCB board thickness: ≥ 1.6 mm

Materials Mouldings and hoods Liquid Crystal Polymer (LCP)
UL 94-V0

Contacts Copper alloy

Contact surface Contact zone selectively plated
acc. to performance level¹⁾

Metal shell Plated steel

Insertion and withdrawal force

Connector on P.C.B.
Press-in without grounding pins
– insertion max. per contact: 120 N
– withdrawal min. per contact: 20 N
Press-in with grounding pins
– insertion max. per grounding pin: 250 N
– withdrawal min. per grounding pin: 30 N

Mating force
9 way ≤ 30 N
15 way ≤ 50 N
25 way ≤ 83 N
37 way ≤ 123 N
50 way ≤ 167 N

Current carrying capacity

The current carrying capacity is limited by maximum temperature of materials for inserts and contacts including terminals.

The current capacity-curve is valid for continuous, not interrupted current-loaded contacts of connectors when simultaneous power on all contacts is given, without exceeding the maximum temperature.

Control and test procedures according to DIN IEC 60 512.

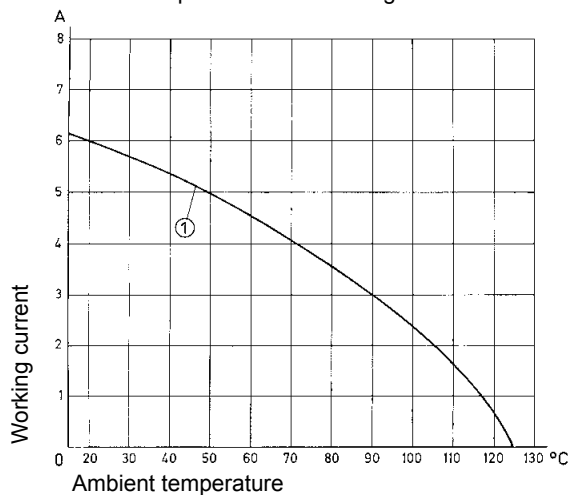

Example: 25 way connector

① Stamped contacts

Contact arrangement View from termination side

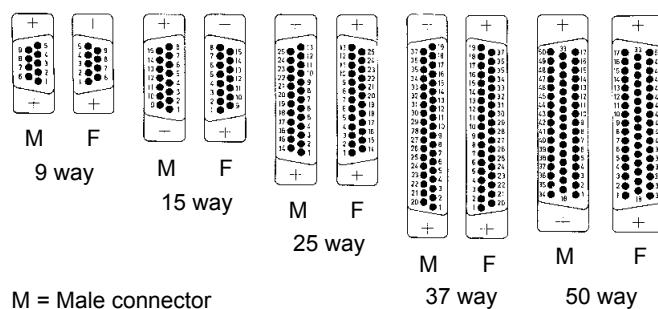

M = Male connector
F = Female connector

Mating conditions as per DIN 41652

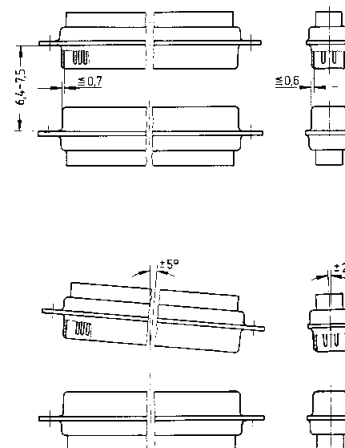

¹⁾ Performance level 3, 50 mating cycles, no gas test
Performance level 2 as per CECC 75301-802, 250 mating cycles, 4 days 4 mixed gas test – IEC 60 512
Performance level 1 as per CECC 75301-802, 500 mating cycles, 10 days 4 mixed gas test – IEC 60 512

Number of contacts

9-50



Press-in, straight with grounding press-in board locks

D-Sub

Identification	No. of contacts	Part number	
Performance levels Explanations see page 05.171 Other performance levels on request		Performance level 3	Performance level 2
Male connector Flange height x = 5.7 mm metal shell with dimples Please insert digit for flange thread or fitted female screw locks M3 ▶ 5 4-40 UNC ▶ 6 fitted screw locks 4-40 UNC ▶ 7 ¹⁾	9 15 25	09 66 164 771 . 09 66 264 771 . 09 66 364 771 .	09 66 164 671 . 09 66 264 671 . 09 66 364 671 .
Female connector Flange height x = 5.7 mm metal shell Please insert digit for flange thread or fitted female screw locks M3 ▶ 5 4-40 UNC ▶ 6 fitted screw locks 4-40 UNC ▶ 7 ¹⁾	9 15 25 37	09 66 154 751 . 09 66 254 751 . 09 66 354 751 . 09 66 454 751 .	09 66 154 651 . 09 66 254 651 . 09 66 354 651 . 09 66 454 651 .
Female connector Flange height x = 6 mm metal shell Please insert digit for flange thread or fitted female screw locks M3 ▶ 1 4-40 UNC ▶ 2 fitted screw locks 4-40 UNC ▶ 3 ¹⁾	9 15 25 37 50	09 66 154 751 . 09 66 254 751 . 09 66 354 751 . 09 66 454 751 . 09 66 554 751 .	09 66 154 651 . 09 66 254 651 . 09 66 354 651 . 09 66 454 651 . 09 66 554 651 .

¹⁾ Fitted screw locks 4-40 UNC not normally kept in stock for performance level 3
 Connector dimensions see page 05.173. Mating conditions see page 05.171.

Number of contacts

9-50

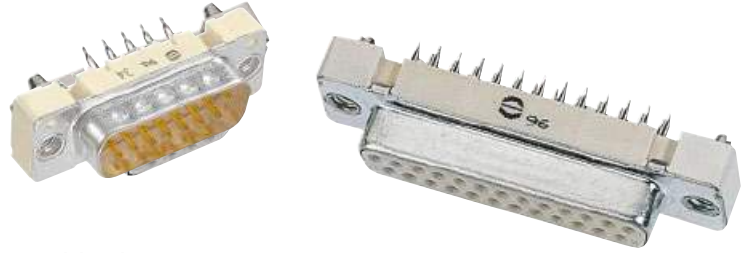

Press-in, straight with grounding press-in board locks

Identification

Drawing

Dimensions in mm

Male connector
9 – 25 contacts

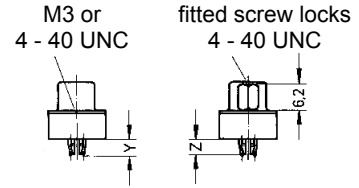
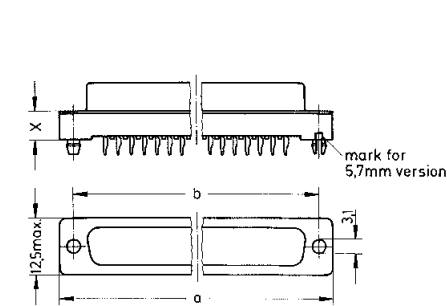

X	Y	Z
6.0 ± 0.2	4.20 ± 0.2	3.5 max.
5.7 ± 0.2	4.35 ± 0.2	3.9 max.

Female connector
9 – 37 contacts

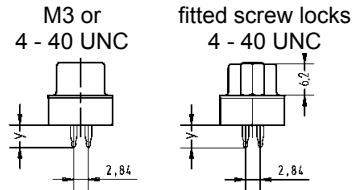
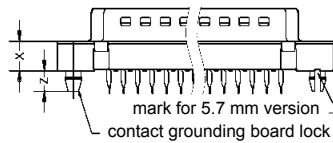

Mating face acc. to: DIN 41652 · CECC 75301-802 · IEC 60807

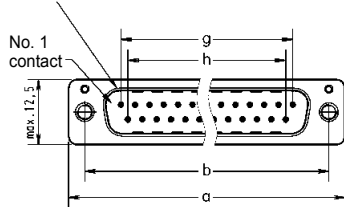

	a	b	g	h
9	31.00	24.90	4 x [2.74] = 10.96	3 x [2.74] = 8.22
15	39.30	33.20	7 x [2.74] = 19.18	6 x [2.74] = 16.44
25	53.10	47.00	12 x [2.76] = 33.12	11 x [2.76] = 30.36
37	69.65	63.55	18 x [2.76] = 49.68	17 x [2.76] = 46.92
50	67.00	61.10	16 x [2.76] = 44.16	15 x [2.76] = 41.40

Female connector
50 contacts

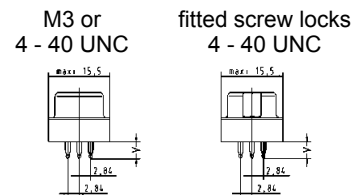
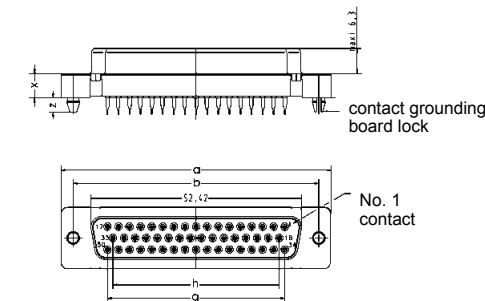

Board drillings

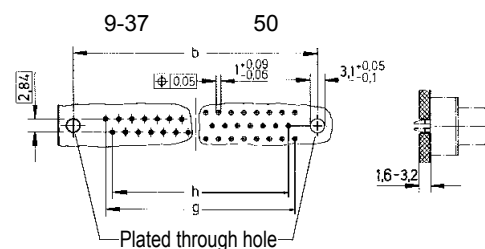

D-Sub

Number of contacts

9-50



Press-in, straight without grounding press-in board locks

D-Sub

Identification	No. of contacts	Part number	
Performance levels Explanations see page 05.171 Other performance levels on request		Performance level 3	Performance level 2
Male connector Flange height x = 5.7 mm metal shell with dimples Please insert digit for flange thread or fitted female screw locks ø 3.1 mm hole ▶ 4 ¹⁾ M3 ▶ 5 4-40 UNC ▶ 6 fitted screw locks 4-40 UNC ▶ 7 ²⁾	9 15 25	09 66 124 770 . 09 66 224 770 . 09 66 324 770 .	09 66 124 670 . 09 66 224 670 . 09 66 324 670 .
Female connector Flange height x = 5.7 mm metal shell Please insert digit for flange thread or fitted female screw locks ø 3.1 mm hole ▶ 4 ¹⁾ M3 ▶ 5 4-40 UNC ▶ 6 fitted screw locks 4-40 UNC ▶ 7 ²⁾	9 15 25 37	09 66 114 750 . 09 66 214 750 . 09 66 314 750 . 09 66 414 750 .	09 66 114 650 . 09 66 214 650 . 09 66 314 650 . 09 66 414 650 .
Female connector Flange height x = 6 mm metal shell Please insert digit for flange thread or fitted female screw locks ø 3.1 mm hole ▶ 0 ¹⁾ M3 ▶ 1 4-40 UNC ▶ 2 fitted screw locks 4-40 UNC ▶ 3 ²⁾	9 15 25 37 50	09 66 114 750 . 09 66 214 750 . 09 66 314 750 . 09 66 414 750 . 09 66 514 750 .	09 66 114 650 . 09 66 214 650 . 09 66 314 650 . 09 66 414 650 . 09 66 514 650 .

1) Not normally kept in stock
 2) Fitted screw locks 4-40 UNC not normally kept in stock for performance level 3
 Connector dimensions see page 05.175. Mating conditions see page 05.171.

Number of contacts

9-50



Press-in, straight without grounding press-in board locks

Identification

Drawing

Dimensions in mm

Male connector
9 – 25 contacts

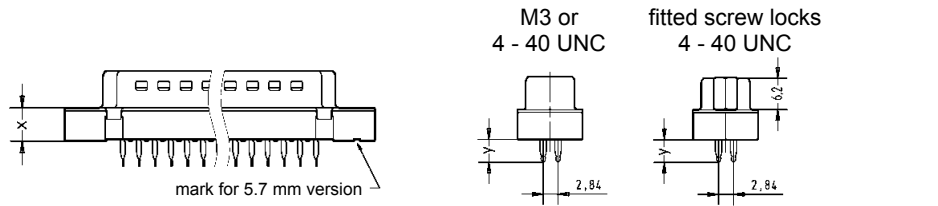

Mating face acc. to: DIN 41652 · CECC 75301-802 · IEC 60807

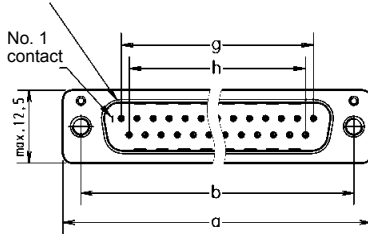

X	Y
6.0 ± 0.2	4.20 ± 0.2
5.7 ± 0.2	4.35 ± 0.2

Female connector
9 – 37 contacts

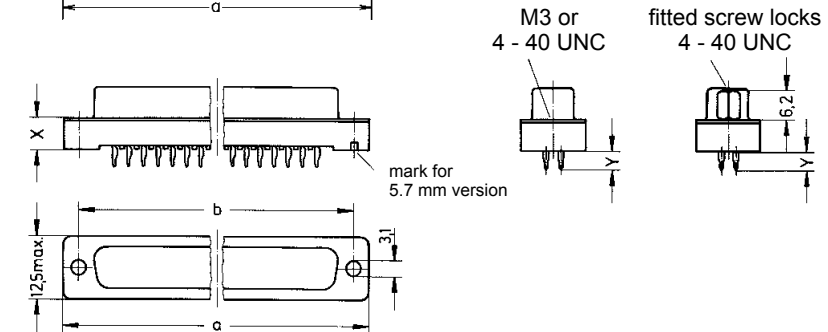

Female connector
50 contacts

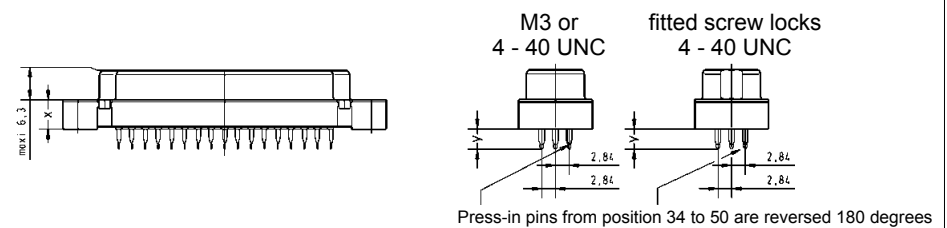

Mating face acc. to: DIN 41652 · CECC 75301-802 · IEC 60807

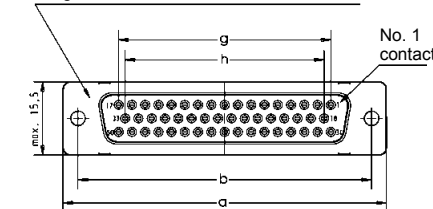

	a	b	g	h
9	31.00	24.90	4 x [2.74] = 10.96	3 x [2.74] = 8.22
15	39.30	33.20	7 x [2.74] = 19.18	6 x [2.74] = 16.44
25	53.10	47.00	12 x [2.76] = 33.12	11 x [2.76] = 30.36
37	69.65	63.55	18 x [2.76] = 49.68	17 x [2.76] = 46.92
50	67.00	61.10	16 x [2.76] = 44.16	15 x [2.76] = 41.40

Board drillings

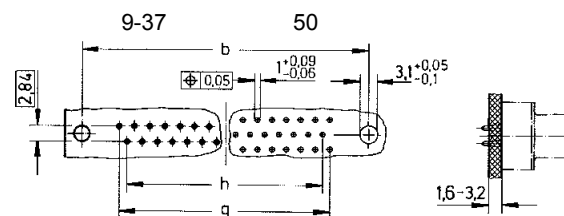

D-Sub

Number of contacts 9, 15, 25, 37
UL recognized

Working current
see current carrying capacity chart
Stamped contacts 6.5 A max.

Test voltage $U_{r.m.s.}$ 1 kV

Clearance and creepage ≥ 1.0 mm

Contact resistance ≤ 10 m Ω
Insulation resistance $\geq 10^{10}$ Ω

Temperature range -55 °C ... +125 °C
during reflow soldering max. + 240 °C for 15 s
The higher temperature limit includes the local ambient and heating effect of the contacts under load. All connectors are suitable for standard reflow processes.

Terminations
a) Solder pins \varnothing 0.6 mm for P.C.B. holes \varnothing 0.8/1 mm
b) Solder pins, angled 90° \varnothing 0.6 mm for P.C.B. holes \varnothing 1 mm

Materials
Mouldings Thermoplastic resin, glass-fibre filled (PCT), UL 94-V0

Contacts Copper alloy

Contact surface
Contact zone selectively gold-plated according to performance level¹⁾

Metal shell Plated steel

Insertion and withdrawal force
Connector on P.C.B.
Solder, straight with clips
– insertion max. per connector: 60 N
– withdrawal min. per connector: 10 N

Mating force
9 way ≤ 30 N
15 way ≤ 50 N
25 way ≤ 83 N
37 way ≤ 123 N

Current carrying capacity

The current carrying capacity is limited by maximum temperature of materials for inserts and contacts including terminals.

The current capacity-curve is valid for continuous, not interrupted current-loaded contacts of connectors when simultaneous power on all contacts is given, without exceeding the maximum temperature.

Control and test procedures according to DIN IEC 60 512.

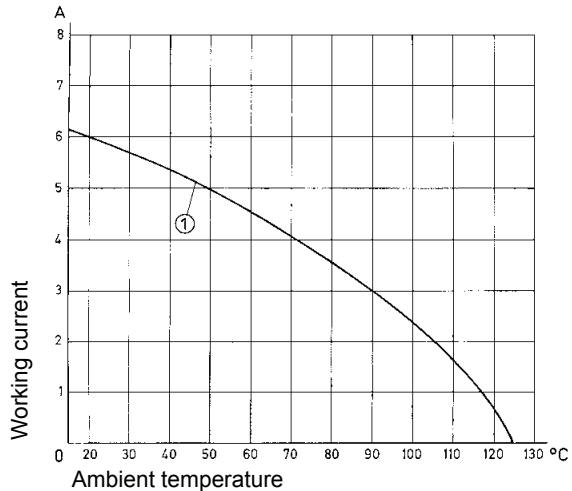

Example: 25 way connector

① Stamped contacts

Contact arrangement View from termination side

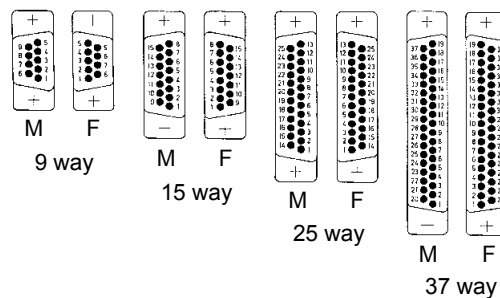

M = Male connector
F = Female connector

Mating conditions as per DIN 41 652

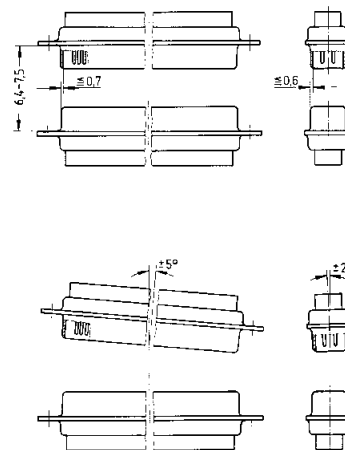

¹⁾ Performance level 3, 50 mating cycles, no gas test
Performance level 2 as per CECC 75 301-802, 250 mating cycles, 4 days 4 mixed gas test – IEC 60 512
Performance level 1 as per CECC 75 301-802, 500 mating cycles, 10 days 4 mixed gas test – IEC 60 512

Identification

Drawing

Dimensions in mm

Standard Versions

Mounting height 7.3 mm
 9-37 way
 for front panel
 4 units of width (TE)

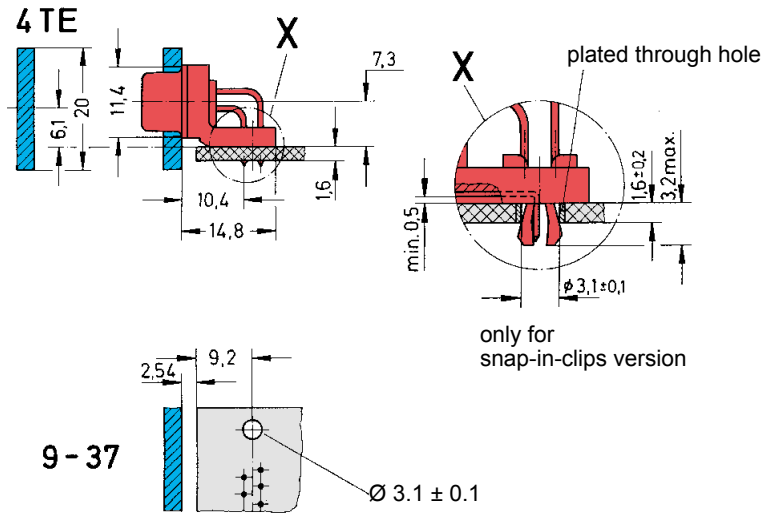

for connectors see pages 05.180 – 05.181

Low-Profile Versions

Mounting height 3.6 mm
 9-37 way
 for front panel
 3 units of width (TE)

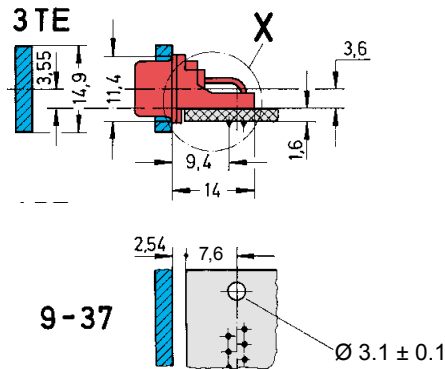

for connectors see pages 05.182 – 05.183

Panel cut out for front/rear mount

Values are taken from the CECC 75301-802

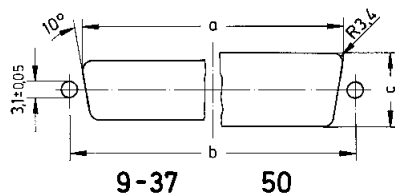

Front mount

	a ± 0.2	b ± 0.13	c ± 0.2
9	22.2	25.0	12.3
15	30.5	33.3	12.3
25	44.3	47.0	12.3
37	60.7	63.5	12.3
50	58.3	61.1	15.1

Rear mount

	a ± 0.2	b ± 0.13	c ± 0.2
9	20.5	25.0	11.4
15	28.8	33.3	11.4
25	42.5	47.0	11.4
37	59.1	63.5	11.4
50	56.3	61.1	14.1

D-Sub

Number of contacts

9-37

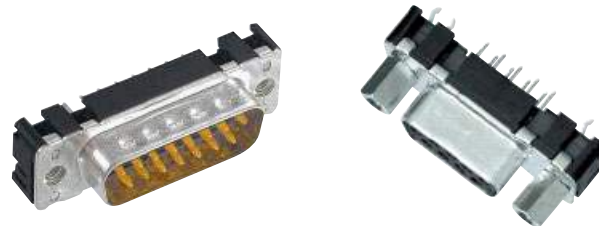

SMC stamped solder pins, straight with/without grounding board locks

Identification	No. of contacts	Part number	
		Performance level 3	Performance level 2
Performance levels Explanations see page 05.176 Other performance levels on request			
Male connector metal shell with dimples			
Without grounding board locks	9 15 25 37	09 65 129 770 . 09 65 229 770 . 09 65 329 770 . 09 65 429 770 .	09 65 129 670 . 09 65 229 670 . 09 65 329 670 . 09 65 429 670 .
With grounding board locks	9 15 25 37	09 65 169 771 . 09 65 269 771 . 09 65 369 771 . 09 65 469 771 .	09 65 169 671 . 09 65 269 671 . 09 65 369 671 . 09 65 469 671 .
Female connector metal shell			
Without grounding board locks	9 15 25 37	09 66 115 750 . 09 66 215 750 . 09 66 315 750 . 09 66 415 750 .	09 66 115 650 . 09 66 215 650 . 09 66 315 650 . 09 66 415 650 .
With grounding board locks	9 15 25 37	09 66 155 751 . 09 66 255 751 . 09 66 355 751 . 09 66 455 751 .	09 66 155 651 . 09 66 255 651 . 09 66 355 651 . 09 66 455 651 .
Please insert digit for flange thread or fitted female screw locks			
M3 ▶ 1 4-40 UNC ▶ 2 fitted screw locks 4-40 UNC ▶ 3 ¹⁾			

¹⁾ Fitted screw locks 4-40 UNC not normally kept in stock for performance level 3
 Connector dimensions see page 05.179. Mating conditions see page 05.176.

Number of contacts

9-37



SMC stamped solder pins, straight with/without grounding board locks

Identification

Drawing

Dimensions in mm

Male connector

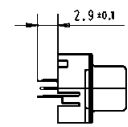
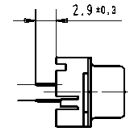
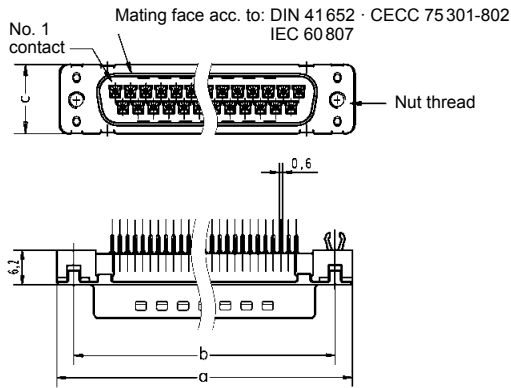

Female connector

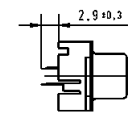
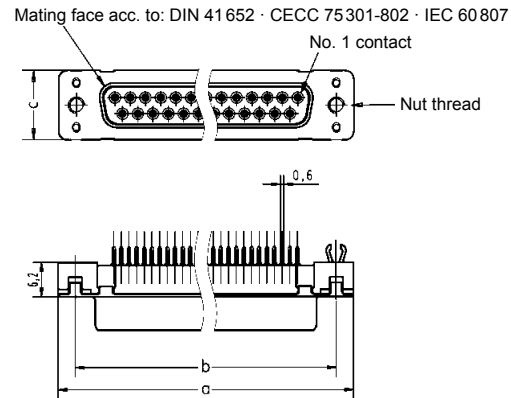

	a	b _{±0.1}	c	g		h			
9	30.9	25.0	12.5	4 x	2.74 =	10.96	3 x	2.74 =	8.22
15	39.2	33.3	12.5	7 x	2.74 =	19.18	6 x	2.74 =	16.44
25	53.1	47.0	12.5	12 x	2.76 =	33.12	11 x	2.76 =	30.36
37	69.4	63.5	12.5	18 x	2.76 =	49.68	17 x	2.76 =	46.92

Board drillings

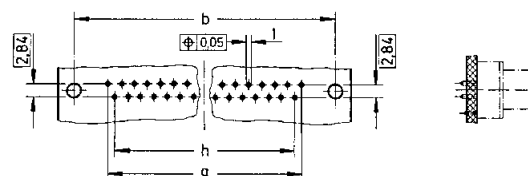

Standard Versions

Number of contacts

Mounting height

9-37

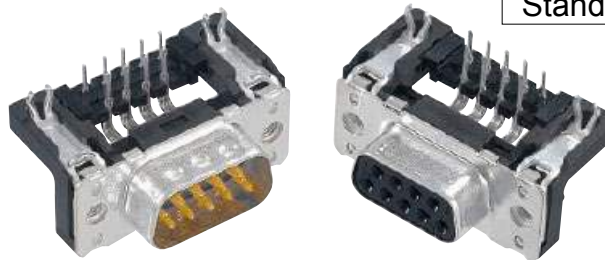
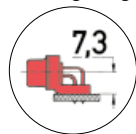

SMC stamped solder pins, angled with grounding board locks

Identification	No. of contacts	Part number		
		Performance level 3	Performance level 2	
Performance levels Explanations see page 05.176 Other performance levels on request				
Male connector metal shell with dimples		2.84 mm pitch	2.84 mm pitch	
	9	09 65 167 781 . 1)	09 65 167 681 . 1)	
	15	09 65 267 781 . 1)	09 65 267 681 . 1)	
	25	09 65 367 781 . 1)	09 65 367 681 . 1)	
	37	09 65 467 781 . 1)	09 65 467 681 . 1)	
		2.54 mm pitch	2.54 mm pitch	
	9	09 65 166 781 .	09 65 166 681 .	
	15	09 65 266 781 .	09 65 266 681 .	
	25	09 65 366 781 .	09 65 366 681 .	
	37	09 65 466 781 .	09 65 466 681 .	
	Female connector metal shell		2.84 mm pitch	2.84 mm pitch
		9	09 66 157 761 . 1)	09 66 157 661 . 1)
		15	09 66 257 761 . 1)	09 66 257 661 . 1)
		25	09 66 357 761 . 1)	09 66 357 661 . 1)
37		09 66 457 761 . 1)	09 66 457 661 . 1)	
		2.54 mm pitch	2.54 mm pitch	
9		09 66 156 761 .	09 66 156 661 .	
15		09 66 256 761 .	09 66 256 661 .	
25		09 66 356 761 .	09 66 356 661 .	
37		09 66 456 761 .	09 66 456 661 .	
Please insert digit for flange thread or fitted female screw locks				
		Ø 3.1 mm hole ▶	0 ¹⁾	
		M3 ▶	1	
		4-40 UNC ▶	2	
fitted screw locks 4-40 UNC ▶	3			

¹⁾ Not normally kept in stock

Standard Versions

Number of contacts

Mounting height

9-37

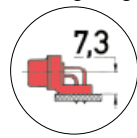

SMC stamped solder pins, angled with grounding board locks

Identification

Drawing

Dimensions in mm

Male connector

Mating face acc. to: DIN 41652 · CECC 75301-802
IEC 60807

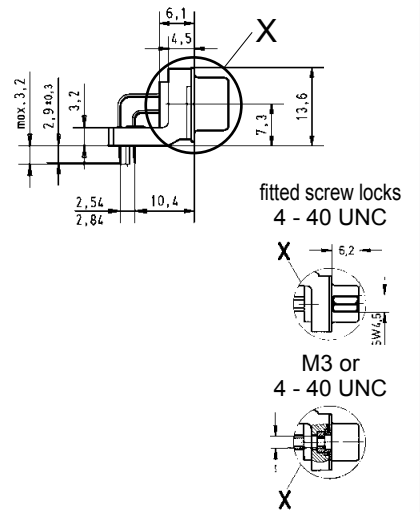
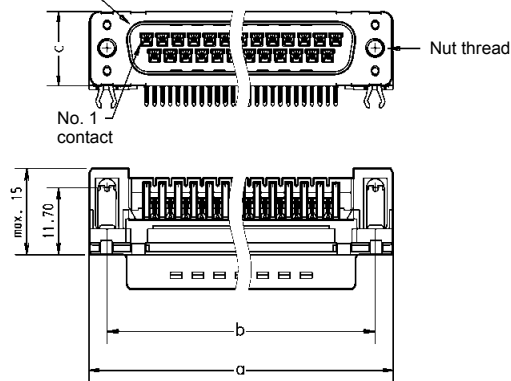

Female connector

Mating face acc. to: DIN 41652 · CECC 75301-802
IEC 60807

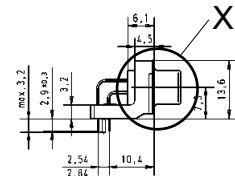
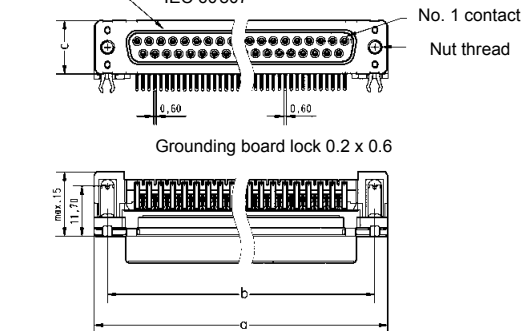

Board drillings

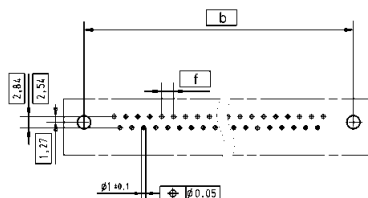

	a	b±0.1	c	f
9	30.90	25.00	12.50	2.74
15	39.20	33.30	12.50	2.74
25	53.10	47.00	12.50	2.76
37	69.40	63.50	12.50	2.76

Number of contacts

Mounting height

9-37

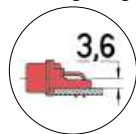

Low-Profile Versions

SMC stamped solder pins, angled with grounding board locks

Identification	No. of contacts	Part number	
Performance levels Explanations see page 05.176 Other contact surfaces on request		Performance level 3	Performance level 2
Male connector metal shell with dimples	9 15 25 37	09 65 166 781 . 09 65 266 781 . 09 65 366 781 . 09 65 466 781 .	09 65 166 681 . 09 65 266 681 . 09 65 366 681 . 09 65 466 681 .
Female connector metal shell	9 15 25 37	09 66 156 761 . 09 66 256 761 . 09 66 356 761 . 09 66 456 761 .	09 66 156 661 . 09 66 256 661 . 09 66 356 661 . 09 66 456 661 .
Please insert digit for flange thread or fitted female screw locks	M3 ▶ 5 4-40 UNC ▶ 6 fitted screw locks 4-40 UNC ▶ 7		

D-Sub

Low-Profile Versions

Number of contacts

Mounting height

9-37

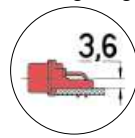

SMC stamped solder pins, angled with grounding board locks

Identification

Drawing

Dimensions in mm

Male connector

Mating face acc. to: DIN 41 652 · CECC 75 301-802
IEC 60 807

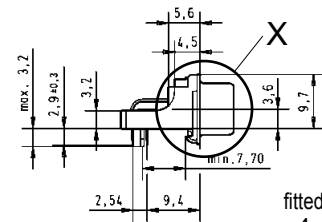
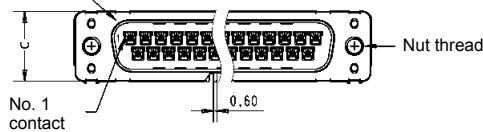

fitted screw locks
4 - 40 UNC

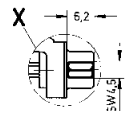

M3 or
4 - 40 UNC

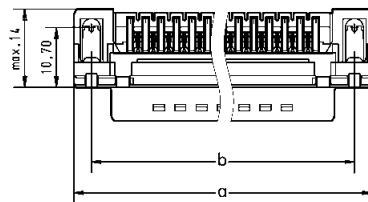
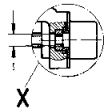

Female connector

Mating face acc. to: DIN 41 652 · CECC 75 301-802
IEC 60 807

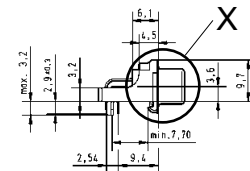
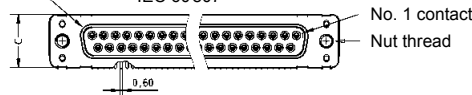

Grounding board lock 0.2 x 0.6

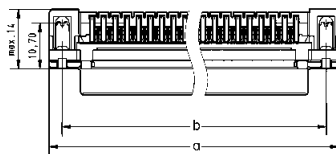

Board drillings

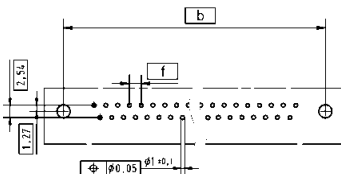

	a	b±0.1	c	f
9	30.90	25.00	12.50	2.74
15	39.20	33.30	12.50	2.74
25	53.10	47.00	12.50	2.76
37	69.40	63.50	12.50	2.76

Number of contacts 9, 15, 25, 37
UL recognized

Working current 5 A

Test voltage $U_{r.m.s.}$ 1 kV

Clearance and creepage ≥ 1.0 mm

Contact resistance < 25 m Ω
Insulation resistance > 5 G Ω

Temperature range as per profile JEDEC 020 D

Terminations Solder pins for P.C.B. pads

Materials
Mouldings LCP black
UL 94-V0
Contacts Phosphorus bronze
Grounding die Zamac
Shell Steel

Contact surface
Contact zone selectively plated
acc. to performance level¹⁾
Grounding die Pure tin
Shell Nickel plated

Mating force

9 way	≤ 30 N
15 way	≤ 50 N
25 way	≤ 83 N
37 way	≤ 123 N

Contact arrangement View from termination side

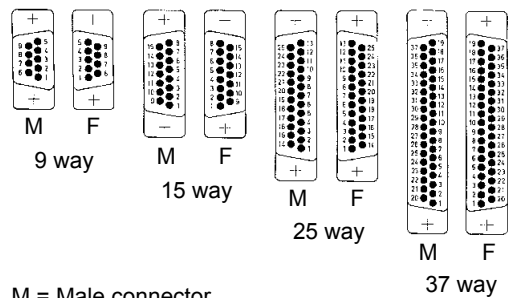

M = Male connector
F = Female connector

Mating conditions as per DIN 41 652

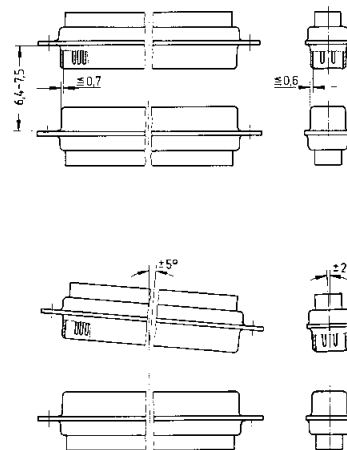

¹⁾ Performance level 3, 50 mating cycles, no gas test
Performance level 2 as per CECC 75301-802, 250 mating cycles, 4 days 4 mixed gas test – IEC 60512

Standard Versions

Number of contacts

9–37



SMT stamped solder pins, angled with grounding dies

Identification	No. of contacts	Part number	
		Performance level 3	Performance level 2
Performance levels Explanations see page 05.184 Other performance levels on request			
Male connector metal shell with dimples	9 15 25 37	09 55 166 78 ... 741 09 55 266 78 ... 741 09 55 366 78 ... 741 09 55 466 78 ... 741	09 55 166 68 ... 741 09 55 266 68 ... 741 09 55 366 68 ... 741 09 55 466 68 ... 741
Female connector metal shell	9 15 25 37	09 55 156 76 ... 741 09 55 256 76 ... 741 09 55 356 76 ... 741 09 55 456 76 ... 741	09 55 156 66 ... 741 09 55 256 66 ... 741 09 55 356 66 ... 741 09 55 456 66 ... 741
Packaging: 140 pieces on a reel			
Please insert digit for flange thread or fitted female screw locks			
M3 ▶ 11 4-40 UNC ▶ 12 non-removable fitted screw locks M3 ▶ 21 non-removable fitted screw locks 4-40 UNC ▶ 22			

Samples

Male connector metal shell with dimples	9 15 25 37	If performance level 3 is required please order as substitute performance level 2	09 55 166 68 ... 333 09 55 266 68 ... 333 09 55 366 68 ... 333 09 55 466 68 ... 333
Female connector metal shell	9 15 25 37		09 55 156 66 ... 333 09 55 256 66 ... 333 09 55 356 66 ... 333 09 55 456 66 ... 333
Packaging 9, 15 contacts: 5 samples 25, 37 contacts: 3 samples			
Please insert digit for flange thread or fitted female screw locks			
4-40 UNC ▶ 12 non-removable fitted screw locks 4-40 UNC ▶ 22			

Standard Versions

Number of contacts

9-37



SMT stamped solder pins, angled with grounding dies

Identification

Drawing

Dimensions in mm

Male connector

M3 or 4-40 UNC

non-removable fitted screw locks M3 or 4-40 UNC

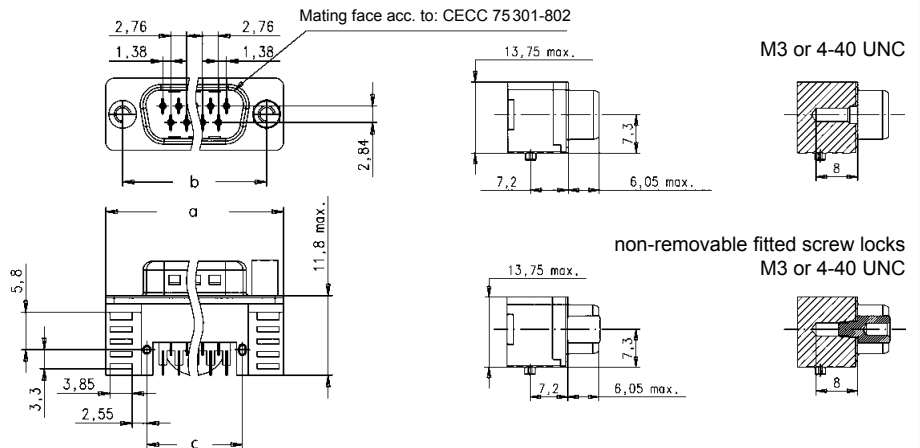

Female connector

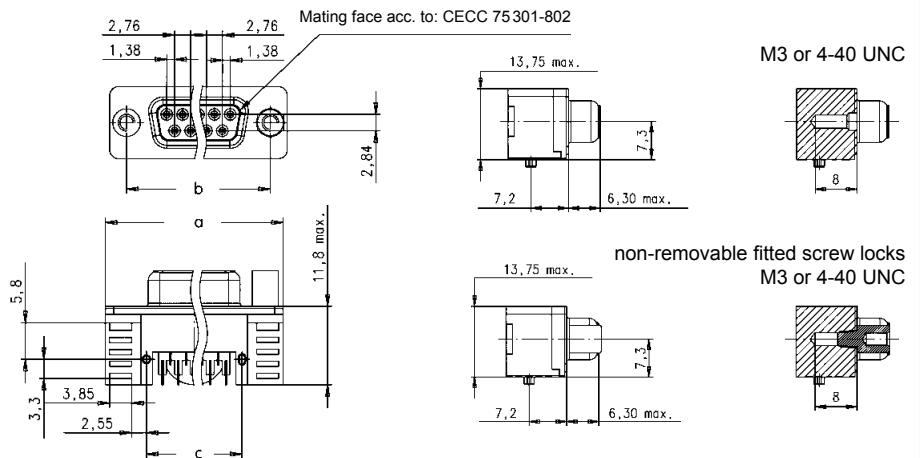

pcb layout

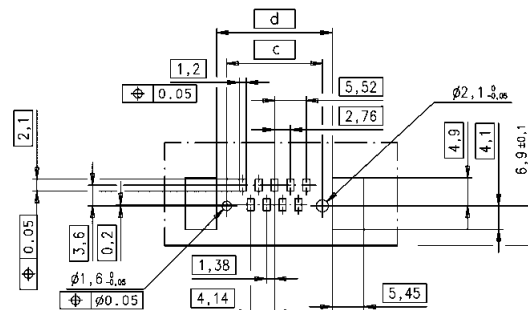

	a	b	c	d
9	31.10	24.99	16.60	20.1
15	39.52	33.32	24.90	28.4
25	53.29	47.04	38.64	42.1
37	69.60	63.50	55.10	58.6

Packaging

(1 reel = 140 pieces)
Reel diameter = 380 mm

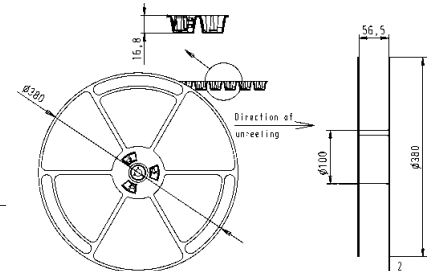
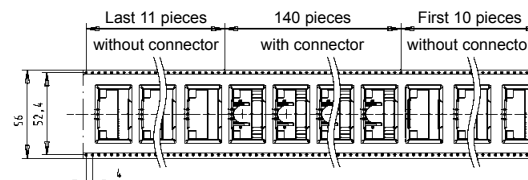

D-Sub

Number of contacts

9–37



SMT stamped solder pins, angled with grounding dies

Identification	No. of contacts	Part number	
		Performance level 3	Performance level 2
Performance levels Explanations see page 05.184 Other performance levels on request			
Male connector metal shell with dimples	9 15 25 37	09 55 166 78 ... 741 09 55 266 78 ... 741 09 55 366 78 ... 741 09 55 466 78 ... 741	09 55 166 68 ... 741 09 55 266 68 ... 741 09 55 366 68 ... 741 09 55 466 68 ... 741
Female connector metal shell	9 15 25 37	09 55 156 76 ... 741 09 55 256 76 ... 741 09 55 356 76 ... 741 09 55 456 76 ... 741	09 55 156 66 ... 741 09 55 256 66 ... 741 09 55 356 66 ... 741 09 55 456 66 ... 741
Packaging: 160 pieces on a reel			
Please insert digit for flange thread or fitted female screw locks			
M3 ▶ 15 4-40 UNC ▶ 16 non-removable fitted screw locks M3 ▶ 19 non-removable fitted screw locks 4-40 UNC ▶ 20			

Samples

Male connector metal shell with dimples	9 15 25 37	If performance level 3 is required please order as substitute performance level 2	09 55 166 68 ... 333 09 55 266 68 ... 333 09 55 366 68 ... 333 09 55 466 68 ... 333
Female connector metal shell	9 15 25 37		09 55 156 66 ... 333 09 55 256 66 ... 333 09 55 356 66 ... 333 09 55 456 66 ... 333
Packaging 9, 15 contacts: 5 samples 25, 37 contacts: 3 samples			
Please insert digit for flange thread or fitted female screw locks			
4-40 UNC ▶ 16 non-removable fitted screw locks 4-40 UNC ▶ 20			

Number of contacts

9–37



SMT stamped solder pins, angled with grounding dies

Identification

Drawing

Dimensions in mm

Male connector

M3 or 4-40 UNC

non-removable fitted screw locks M3 or 4-40 UNC

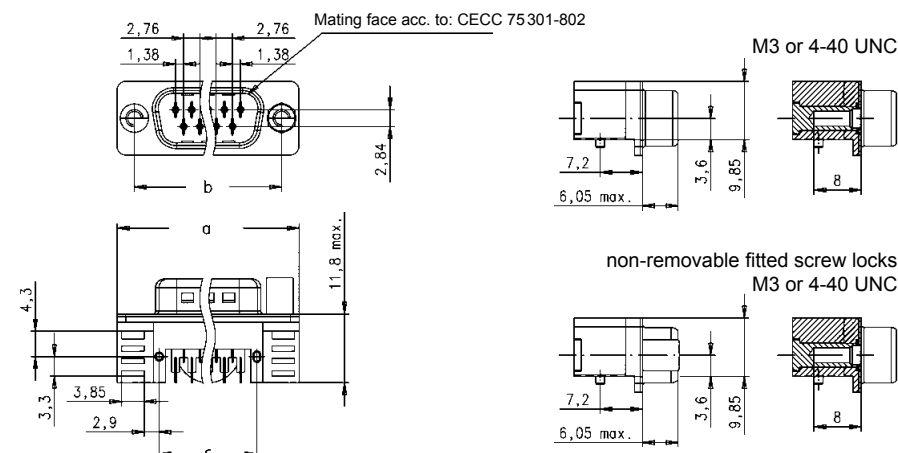

Female connector

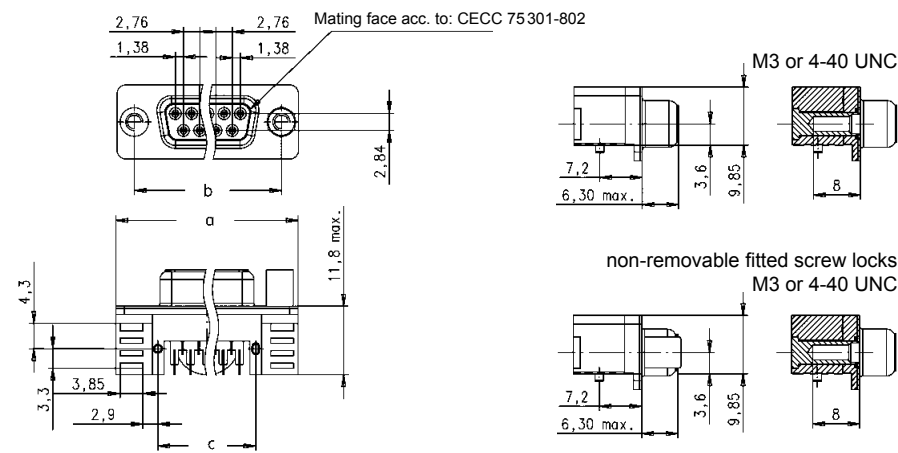

pcb layout

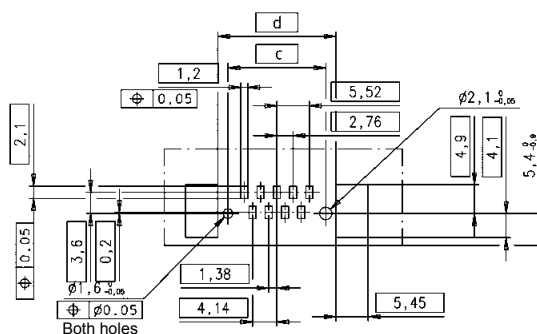

	a	b	c	d
9	31.10	24.99	16.60	20.1
15	39.52	33.32	24.90	28.4
25	53.29	47.04	38.64	42.1
37	69.60	63.50	55.10	58.6

Packaging

(1 reel = 160 pieces)
Reel diameter = 330 mm

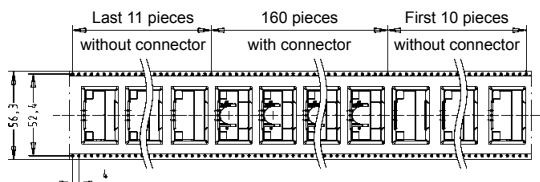

Number of contacts

9–37



SMT stamped solder pins, straight without grounding pins

Identification	No. of contacts	Part number	
Performance levels Explanations see page 05.184 Other performance levels on request		Performance level 3	Performance level 2
Male connector metal shell with dimples	9 15 25 37	09 55 129 78 ... 741 09 55 229 78 ... 741 09 55 329 78 ... 741 09 55 429 78 ... 741	09 55 129 68 ... 741 09 55 229 68 ... 741 09 55 329 68 ... 741 09 55 429 68 ... 741
Female connector metal shell	9 15 25 37	09 55 115 76 ... 741 09 55 215 76 ... 741 09 55 315 76 ... 741 09 55 415 76 ... 741	09 55 115 66 ... 741 09 55 215 66 ... 741 09 55 315 66 ... 741 09 55 415 66 ... 741
Packaging: 140 pieces on a reel			
Please insert digit for flange thread or fitted female screw locks			
M3 ▶ 11 4-40 UNC ▶ 12 fixed screw locks M3 ▶ 21 fixed screw locks 4-40 UNC ▶ 22			

Samples

Male connector metal shell with dimples	9 15 25 37	If performance level 3 is required please order as substitute performance level 2	09 55 129 68 ... 333 09 55 229 68 ... 333 09 55 329 68 ... 333 09 55 429 68 ... 333
Female connector metal shell	9 15 25 37		09 55 115 66 ... 333 09 55 215 66 ... 333 09 55 315 66 ... 333 09 55 415 66 ... 333
Packaging 9, 15 contacts: 5 samples 25, 37 contacts: 3 samples			
Please insert digit for flange thread or fitted female screw locks			
4-40 UNC ▶ 12 fixed screw locks 4-40 UNC ▶ 22			

Number of contacts

9-37



SMT stamped solder pins, straight without grounding pins

Identification

Drawing

Dimensions in mm

Male connector

M3 or 4-40 UNC non-removable fitted screw locks M3 or 4-40 UNC

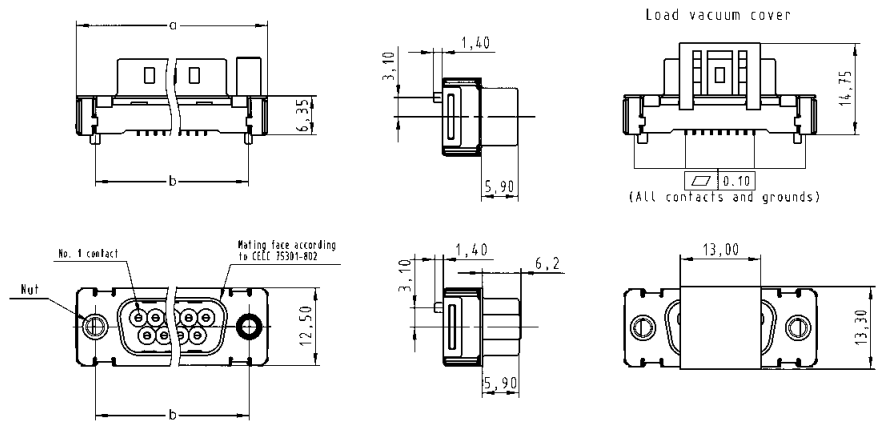

Female connector

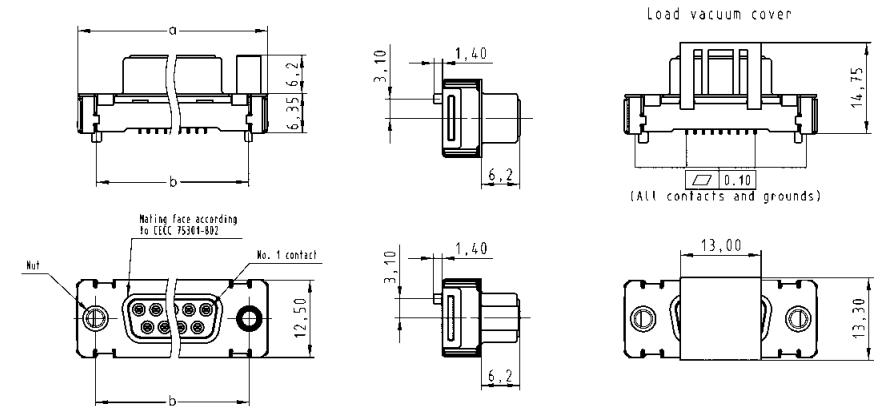

pcb layout

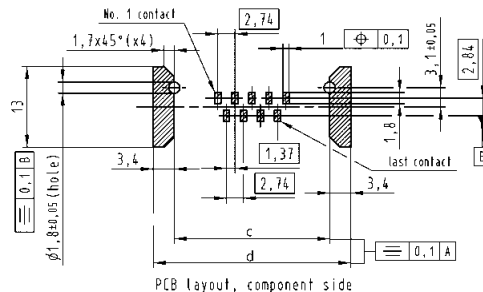

	a	b	c	d
9	31.12	25.00	25.0	31.8
15	39.45	33.33	33.3	40.1
25	53.35	47.04	47.0	53.8
37	69.62	63.50	63.5	70.3

Packaging

(1 reel = 140 pieces)
Reel diameter = 380 mm

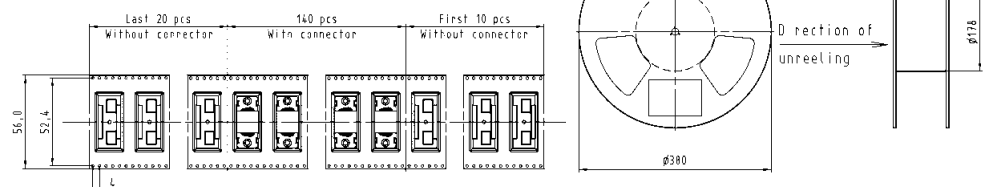

Number of contacts

9–37



SMT stamped solder pins, straight with grounding pins

Identification	No. of contacts	Part number	
Performance levels Explanations see page 05.184 Other performance levels on request		Performance level 3	Performance level 2
Male connector			
metal shell with dimples	9	09 55 169 78 .. 741	09 55 169 68 .. 741
	15	09 55 269 78 .. 741	09 55 269 68 .. 741
	25	09 55 369 78 .. 741	09 55 369 68 .. 741
	37	09 55 469 78 .. 741	09 55 469 68 .. 741
Female connector			
metal shell	9	09 55 155 76 .. 741	09 55 155 66 .. 741
	15	09 55 255 76 .. 741	09 55 255 66 .. 741
	25	09 55 355 76 .. 741	09 55 355 66 .. 741
	37	09 55 455 76 .. 741	09 55 455 66 .. 741
Packaging: 140 pieces on a reel			
Please insert digit for flange thread or fitted female screw locks			
M3 ▶ 11			
4-40 UNC ▶ 12			
fixed screw locks M3 ▶ 21			
fixed screw locks 4-40 UNC ▶ 22			

Samples

Male connector			
metal shell with dimples	9	If performance level 3 is required please order as substitute performance level 2	09 55 169 68 .. 333
Female connector			
metal shell	9		09 55 155 66 .. 333
Packaging			
9, 15 contacts: 5 samples			
25, 37 contacts: 3 samples			
Please insert digit for flange thread or fitted female screw locks			
4-40 UNC ▶ 12			
fixed screw locks 4-40 UNC ▶ 22			

Number of contacts

9-37



SMT stamped solder pins, straight with grounding pins

Identification

Drawing

Dimensions in mm

Male connector

M3 or 4-40 UNC non-removable fitted screw locks M3 or 4-40 UNC

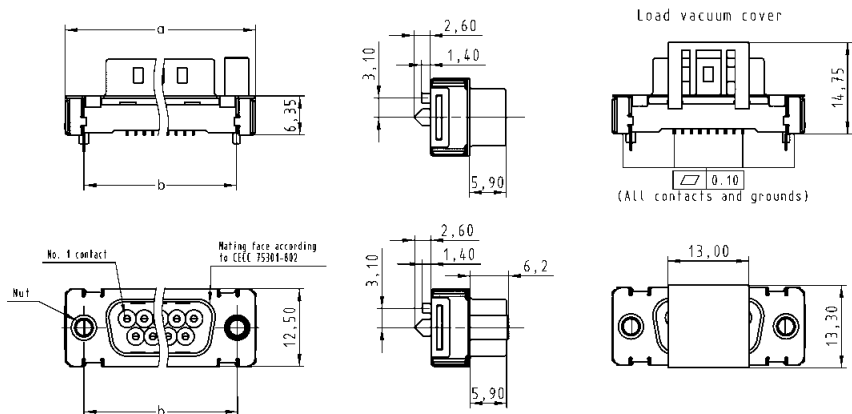

Female connector

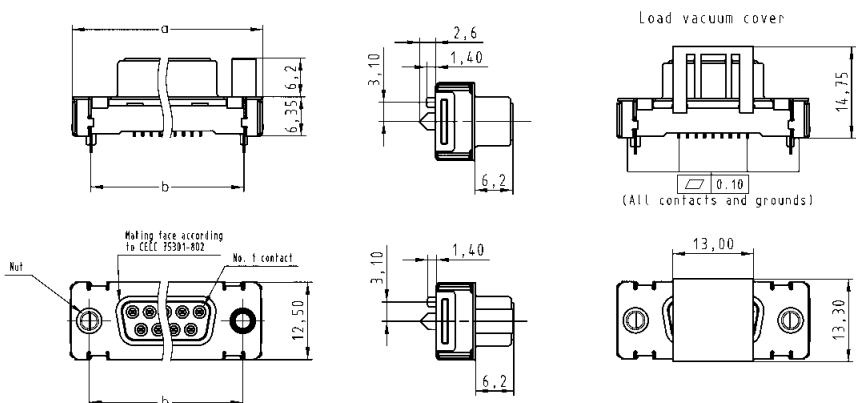

pcb layout

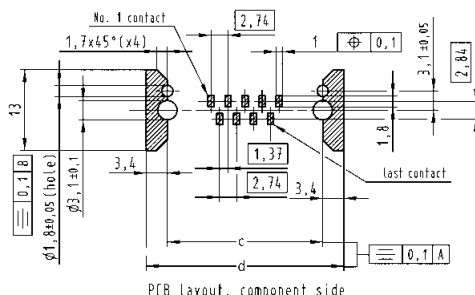

	a	b	c	d
9	31.12	25.00	25.0	31.8
15	39.45	33.33	33.3	40.1
25	53.35	47.04	47.0	53.8
37	69.62	63.50	63.5	70.3

Packaging

(1 reel = 140 pieces)
Reel diameter = 380 mm

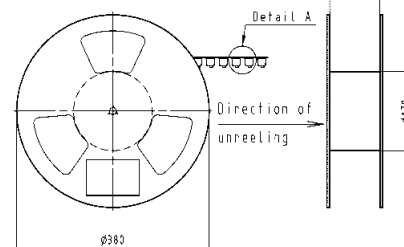
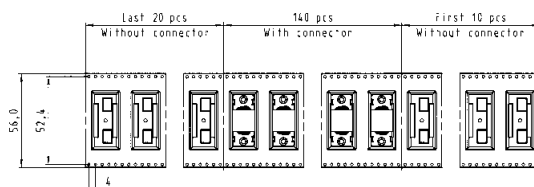

D-Sub



Cable assemblies

Identification	Part number	Drawing	Dimensions in mm
<p>Cable assembly D-Sub HD 78-pole</p> <p>Hood: shielded plastic hood with side entry, screw 4-40 UNC</p> <p>Cable: 39 twisted pairs, AWG 26, double shielded, PVC</p> <p>Wiring: 1:1</p> <p>Length: L = 0.5 m L = 1.0 m L = 2.0 m L = 5.0 m L = 10.0 m L = 20.0 m</p>	<p>33 56 212 0050 028 33 56 213 1000 002 33 56 213 2000 016 33 56 212 0500 029 33 56 212 1000 030 33 56 212 2000 031</p>		
<p>Cable assembly D-Sub HD 44-pole</p> <p>Hood: shielded plastic hood with side entry, screw 4-40 UNC</p> <p>Cable: 22 twisted pairs, AWG 26, double shielded, PVC</p> <p>Wiring: 1:1</p> <p>Length: L = 0.5 m L = 1.0 m L = 1.5 m L = 2.0 m L = 5.0 m L = 10.0 m</p>	<p>33 56 213 0500 023 33 56 213 1000 024 33 56 213 1500 022 33 56 213 2000 025 33 56 213 5000 026 33 56 212 1000 027</p>		
<p>Cable assembly D-Sub HD 44-pole</p> <p>Hood: metal hood with top entry, screw 4-40 UNC</p> <p>Cable: 24 twisted pairs, AWG 26, double shielded, PVC</p> <p>Wiring: 1:1</p> <p>Length: L = 0.5 m L = 1.0 m L = 5.0 m L = 10.0 m L = 20.0 m</p>	<p>33 56 212 0050 032 33 56 212 0100 033 33 56 212 0500 034 33 56 212 1000 035 33 56 212 2000 036</p>		

D-Sub



Cable assemblies

Identification	Part number	Drawing	Dimensions in mm
<p>Cable assembly D-Sub HD 44-pole Hood: overmoulded with side entry Cable: 24 twisted pairs, solid wires, AWG 26, shielded, halogen free Wiring: 1:1</p> <p>Length: L = 0.5 m L = 1.0 m L = 2.0 m L = 5.0 m</p>	<p>33 56 224 5000 001 33 56 221 0010 001 33 56 221 0020 001 33 56 221 0050 001</p>		
<p>Cable assembly D-Sub 9-pole Hood: shielded plastic hood with side entry, screw 4-40 UNC Cable: 5 twisted pairs, stranded, AWG 24, shielded, PVC Wiring: 1:1</p> <p>Length: L = 0.5 m L = 1.0 m L = 1.5 m L = 2.0 m L = 5.0 m</p>	<p>33 66 214 5000 058 33 66 213 1000 059 33 66 213 1500 060 33 66 213 2000 061 33 66 213 5000 062</p>		

Identification	No. of contacts	Part number	Drawing	Dimensions in mm
----------------	-----------------	-------------	---------	------------------

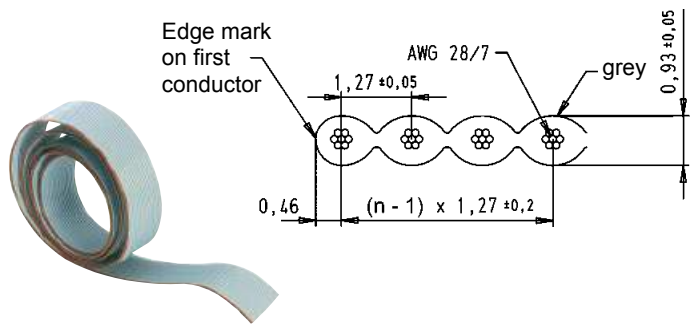

Flat cable grey UL AWM-style 2651 CSA	9	09 18 009 700 <input type="checkbox"/>
	15	09 18 015 700 <input type="checkbox"/>
	25	09 18 025 700 <input type="checkbox"/>
	37	09 18 037 700 <input type="checkbox"/>



- Conductor material _____ Copper tinned
- Gauge _____ AWG 28/7 0.089 mm²
- Voltage rating _____ 300 V_{r.m.s.}
- Current rating at 25 °C _____ 2.1 A max.
- Capacity unbalanced _____ 45.9 pF/m
- Impedance unbalanced _____ 105 Ω
- Propagation delay _____ 4.9 ns/m nominal
- Insulation material _____ PVC
- Temperature rating (operating) _____ -20 °C ... +105 °C
- Temperature rating (static) _____ -30 °C ... +105 °C
- Flammability rating _____ UL: VW-1
- Insulation resistance _____ > 100 MΩ/km

Length per reel	
30.48 m (100 feet)	1
100 m (328 feet)	4

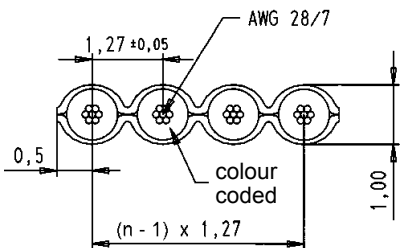
D-Sub

Identification	No. of contacts	Part number	Drawing	Dimensions in mm
<p>Flat cable colour coded</p> <p>Length per reel 30.48 m (100 feet)</p> <p>UL AWM-style 2651</p>	<p>9</p> <p>15</p> <p>25</p> <p>37</p>	<p>09 18 009 7005</p> <p>09 18 015 7005</p> <p>09 18 025 7005</p> <p>09 18 037 7005</p>	 <p>Colour code sequence (in 10 steps) brown, red, orange, yellow, green, blue, violet, grey, white, black</p>  <p>Conductor material _____ Copper tinned Gauge _____ AWG 28/7 0.09 mm² Voltage rating _____ 300 V_{r.m.s.} Current rating at 25 °C _____ 2.1 A max. Conductor resistance _____ 221 mΩ/m Capacity unbalanced _____ 42.7 pF/m Impedance unbalanced _____ 105 Ω Inductance unbalanced _____ 0.68 μH/m Signal delay _____ 4.9 ns/m Insulation material _____ PVC Temperature rating (operating) _____ -20 °C ... +105 °C Temperature rating (static) _____ -30 °C ... +105 °C Flammability rating _____ UL: VW 1 Insulation resistance _____ 100 MΩ/km</p>	

D-Sub

Important: always store reel vertically

Identification	No. of contacts	Part number	Drawing	Dimensions in mm
Round flat cable with screening (shielding) UL listed PLCC CL2 CSA certified AWM FT-1	9	09 18 009 70	<p>Slit section</p> <p>① Flat cable, AWG 28/7 ② Aluminium / Polyester tape (spiral wrap) ③ 85 % minimum coverage tinned copper braid ④ Outer jacket: black PVC</p>	ø max. 6.86 7.62 9.14 10.41
	15	09 18 015 70		
	25	09 18 025 70		
	37	09 18 037 70		
	Length per reel			
30.48 m (100 feet)	07			
100 m (328 feet)	10*			
without screening (shielding) UL listed PLCC CL2 CSA certified AWM FT-1	9	09 18 009 7008	<p>Slit section</p> <p>① Flat cable, AWG 28/7 ② Clear polyester ③ Outer jacket: black PVC</p>	6.35 6.86 8.38 9.65
	15	09 18 015 7008		
	25	09 18 025 7008		
	37	09 18 037 7008		
	Length per reel			
30.48 m (100 feet)				

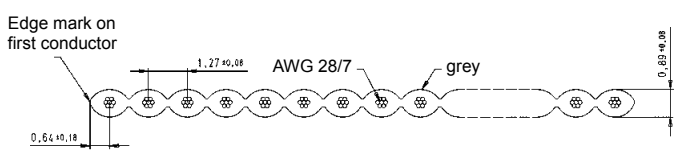

No. of contacts	a	b	c
9 to 25	19.05	19.05	38.10
37	38.10	19.05	57.15

- Conductor material _____ Copper tinned
- Gauge _____ AWG 28/7 0.089 mm²
- Voltage rating _____ 300 V_{r.m.s.}
- Conductor resistance _____ 225 mΩ/m
- Capacity unbalanced _____ 78.7 pF/m
- Impedance unbalanced _____ 75 Ω
- Signal delay _____ 5.25 ns/m nom.
- Insulation material _____ PVC
- Temperature rating _____ -20 °C ... +105 °C
- Flammability rating _____ UL: VW 1
- Insulation resistance _____ 10⁴ MΩ/km

* Only available for 37 contacts
 Important: always store reels vertically

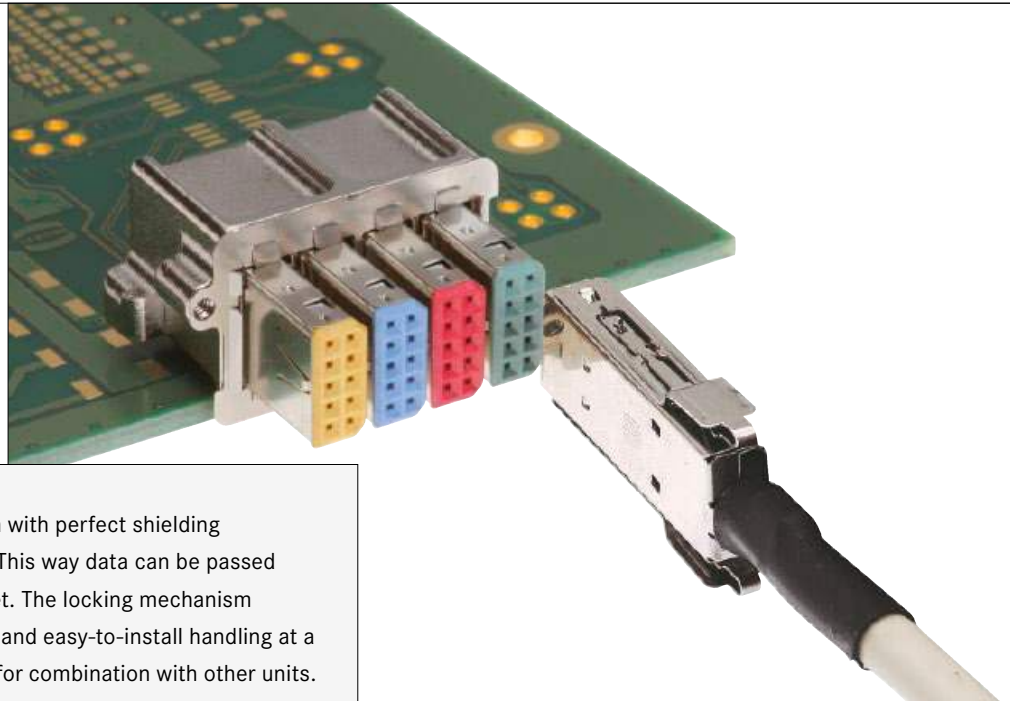

The highest data rates in combination with perfect shielding characterize the *har-link*® connector. This way data can be passed on optimally within the control cabinet. The locking mechanism ensures a vibration-proof connection and easy-to-install handling at a minimum size and maximum options for combination with other units. HARTING offers assembled system cables with shielded or unshielded twisted pairs for the *har-link*® connector family.

Application profile:

CONNECTION TYPE		ENVIRONMENT		APPLICATION						
Board to Board	Cable/Wire to Board	IP20	IP65 / IP67	Data	Signal	Power	high performance			
							Data transfer rate	Shielding	Number of contacts, contact density	Voltage, working current
Cable termination			PCB termination			Application standard				
<i>Han-Quick Lock</i> ®	IDC	Crimp	THT	SMC	SMT					
Screw	Cage clamp	Axial screw	Press-in					Housing integration		
				Separate housing		Integrated housing				

Contents

Page

<i>har-link</i> [®] connector system – introduction	07.02
<i>har-link</i> [®] connector system – general information	07.04
Technical characteristics	07.05
Male and female connectors	07.06
Accessories and cable assemblies	07.07

METRIC *har-link*® INTERFACE CONNECTORS IN 2.0 mm PITCH

HARTING's modular interface connector system, *har-link*® in 2.0 mm pitch, allows data transfer rates up to 2 Gbit/s.

The *har-link*® connector system of HARTING complies with the requirements of IEC 61076-4-107 and is a compact and robust PCB-to-cable interface with excellent data transmission properties.

All dimensions of the *har-link*® connector are in accordance with IEC 917 and IEEE P 1301 specifications, allowing an easy implementation into both metric and inch-based systems.

har-link® also supports hot plugging as required by modern bus systems such as CompactPCI, S-bus and VME.

har-link® allows data transmission up to 2 Gbit/s per pair and is therefore perfectly suited for modern transmission protocols such as Low Voltage Differential Signals (LVDS).

The thorough EMI shielding of the *har-link*® connector is a guarantee of its superior performance in the EMI-polluted environment.

The high temperature resistant material of the female *har-link*® connector supports reflow soldering.

In addition, HARTING provides cable assemblies. A crimping tool range for terminating male *har-link*® connectors is also available.

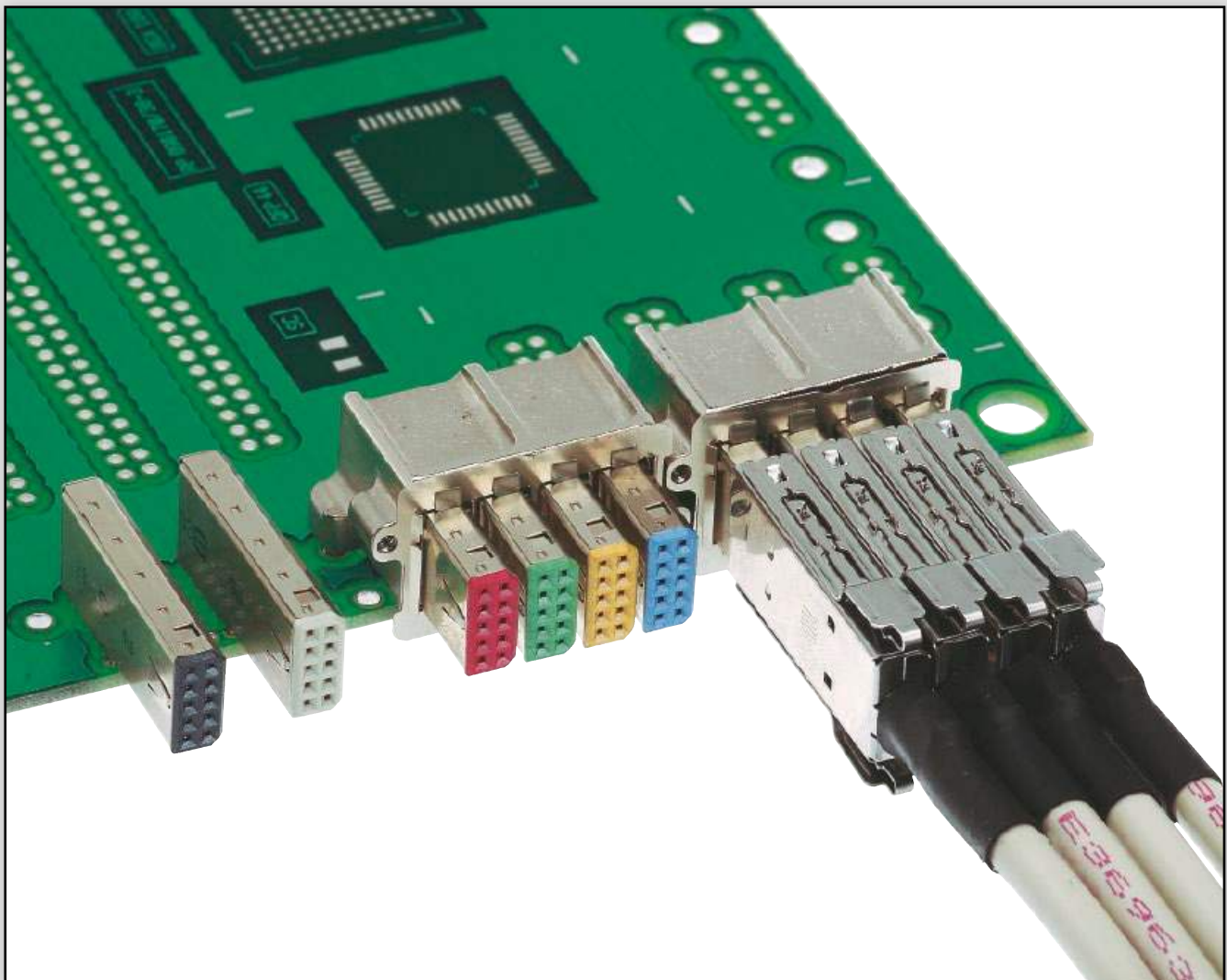

- Data transmission up to 2 Gbit/s
- Is perfectly suited for modern transmission protocols such as Low Voltage Differential Signals (LVDS)

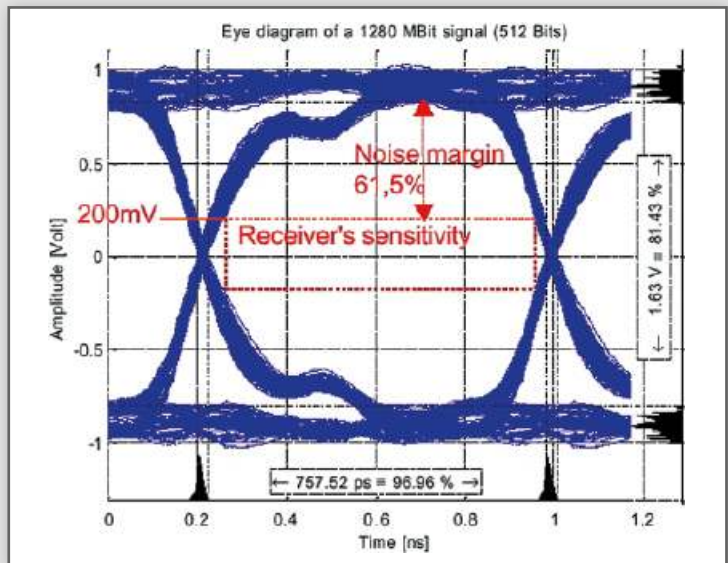

- A screening attenuation of more than 50 dB up to 1 GHz
- The high temperature resistant material of the female *har-link*® connector supports reflow soldering

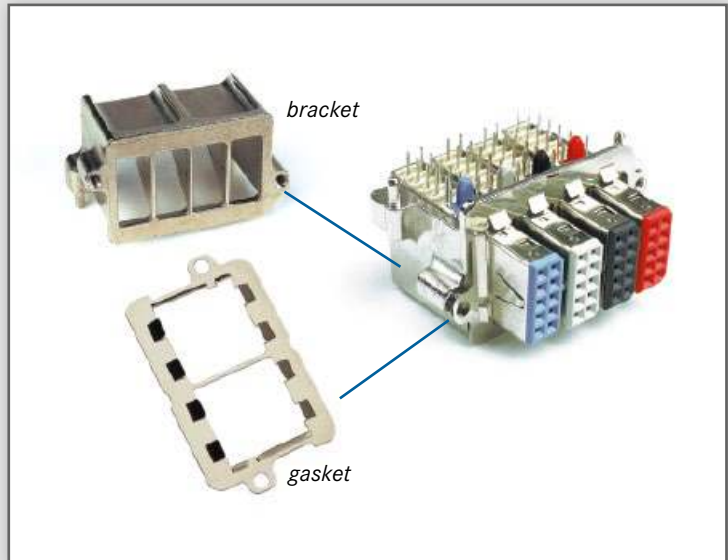

- Shielding with integrated locking levers
- Due to the locking levers on both sides of the male connector, the connection withstands a pulling force up to 80 N



The **harlink®** connector system of HARTING complies with the requirements of IEC 61076-4-107 and is a compact and robust pcb-to-cable interface with excellent data transmission properties for high-speed networking and telecommunications.

All dimensions of the **harlink®** connector are in accordance with IEC 917 and IEEE P 1301 requirements, which allows for easy implementation into both metric and inch-based systems. In addition, **harlink®** supports hot plugging as required by modern bus systems such as CompactPCI, S-bus and VME.

harlink® allows data transmission up to 2 Gbit/s per pair and is therefore perfectly suited for modern transmission protocols such as Low Voltage Differential Signals (see Fig. 1). The design of the **harlink®** connector allows differential pairs to be placed horizontally (parallel to the pcb), thus reducing the skew at high frequencies and considering high signal integrity.

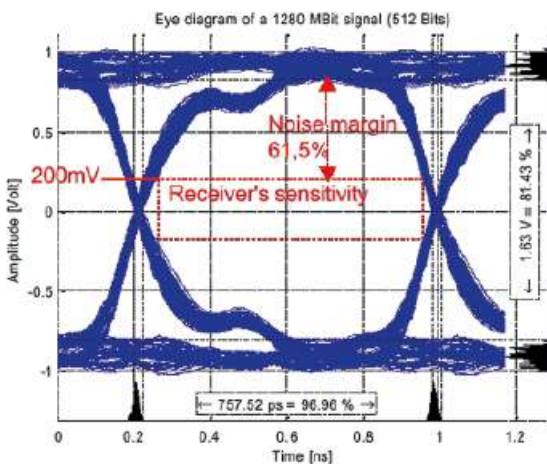

Fig. 1: Eye diagram of a 1280 MBit signal (512 Bits)

The metal shells of the **harlink®** connector are a guarantee for its superior performance in the EMI-polluted environment (see Fig. 2).



Fig. 2: 360° screened-can construction with locking levers

To reach a screening attenuation of more than 50 dB up to 1 GHz, HARTING offers brackets covering each connector in conjunction with a gasket, which is compressed between the bracket and the front panel (see Fig. 3).

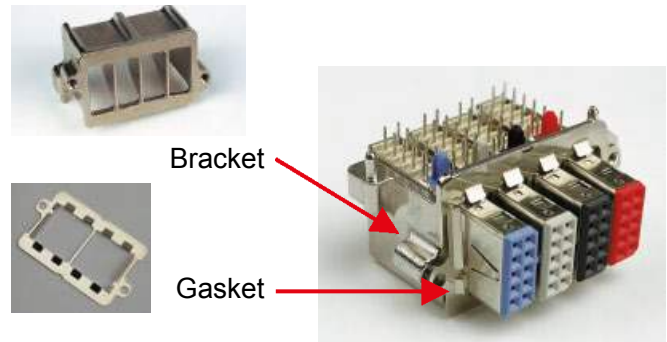

Fig. 3: 4 cavities bracket and gasket

Once plugged, the mated pair shows excellent mating safety. Due to the locking levers on both sides of the male connector, the connection withstands a pulling force of up to 80 N (see Fig. 2).

The high temperature resistant material of the **harlink®** female connector body supports the safe reflow soldering process. For easy identification of female modules, six different colours are available (see Fig. 4).

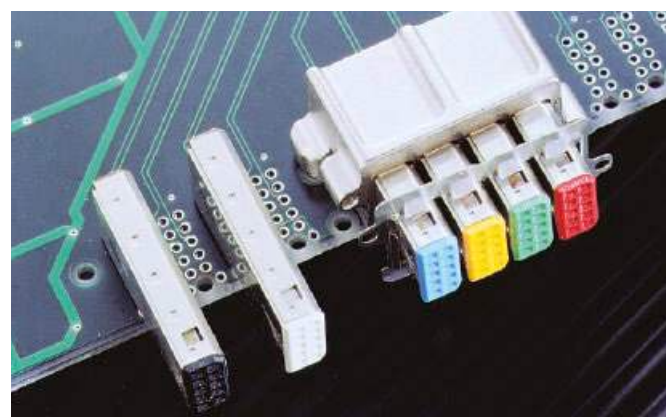
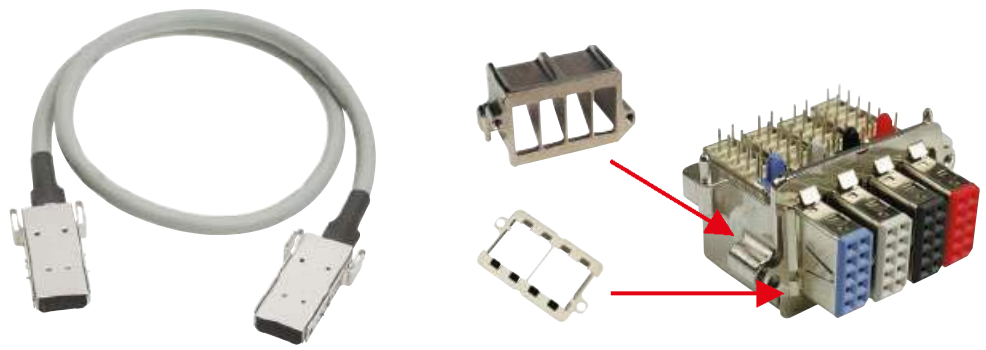

Fig. 4: Female modules

In addition to single connectors, HARTING provides cable assemblies with unshielded twisted pairs or with shielded twisted pairs for high speed applications such as IEEE 1355. A crimping tool range for terminating the male **harlink®** connectors is available.

Number of contacts	10	
Approvals	IEC 61076-4-107 UL recognized: E102079	
Contact pitch Connector pitch	2 mm 6 mm	
Working current	1.5 A at 70 °C	
Test voltage $U_{r.m.s.}$	750 V	
Contact resistance Insulation resistance	$\leq 35 \text{ m}\Omega$ $\geq 10^{10} \Omega$	
Temperature range during reflow soldering	-55 °C ... +125 °C female: max. + 260 °C for 60 s	
Mating cycles	250, performance level 2	
Terminations	Insulation displacement (male), AWG 28/7 - 30/7, AWG 30 solid Solder pins for $\varnothing 0.6 \text{ mm}$ min. (female)	
Insertion force Withdrawal force	10 N max. / module 2 N min. / module (without locking levers)	
Latching system	Locking levers	
Materials Mouldings Contacts Shells Contact surface Contact zone	Male connector: Polyester, UL 94-V0 Female connector: High temperature plastic material, UL 94-V0 Copper alloy Male connector: Stainless steel Female connector: Silver nickel Selectively plated according to performance level	



Accessories and cable assemblies

Identification	Part number	Drawing	Dimensions in mm																								
Bracket with four cavities	27 71 040 0001	<p>Board drillings Component side</p>																									
Gasket with four cavities	27 71 040 0002																										
Standard har-link® cable assembly Cable: 5 twisted pairs, AWG 28, shielded, PVC Wiring: 1:1 Length: L = 0.5 m L = 1.0 m L = 2.0 m	33 27 243 0500 001 33 27 243 1000 002 33 27 243 2000 003	<p>har-link male IDC connector</p>																									
High end har-link® cable assembly Cable: 5 twisted pairs, AWG 30, double shielded, PVC Wiring: 1:1 Length: L = 0.5 m L = 1.0 m L = 2.0 m	33 27 243 0500 006 33 27 243 1000 007 33 27 243 2000 008																										
Cable: 5 twisted pairs, AWG 30, double shielded, PVC Wiring: acc. to IEEE 1355 Length: L = 0.5 m L = 1.0 m L = 2.0 m	33 27 243 0500 015 33 27 243 1000 016 33 27 243 2000 017	IEEE 1355 wiring	<table border="1"> <thead> <tr> <th>Connector 1</th> <th>Connector 2</th> <th>Connector 1</th> <th>Connector 2</th> </tr> </thead> <tbody> <tr> <td>2-e</td> <td>1-a</td> <td>1-c</td> <td>1-c</td> </tr> <tr> <td>1-e</td> <td>2-a</td> <td>2-b</td> <td>1-d</td> </tr> <tr> <td>2-d</td> <td>1-b</td> <td>1-b</td> <td>2-d</td> </tr> <tr> <td>1-d</td> <td>2-b</td> <td>2-a</td> <td>1-e</td> </tr> <tr> <td>2-c</td> <td>2-c</td> <td>1-a</td> <td>2-e</td> </tr> </tbody> </table>	Connector 1	Connector 2	Connector 1	Connector 2	2-e	1-a	1-c	1-c	1-e	2-a	2-b	1-d	2-d	1-b	1-b	2-d	1-d	2-b	2-a	1-e	2-c	2-c	1-a	2-e
Connector 1	Connector 2	Connector 1	Connector 2																								
2-e	1-a	1-c	1-c																								
1-e	2-a	2-b	1-d																								
2-d	1-b	1-b	2-d																								
1-d	2-b	2-a	1-e																								
2-c	2-c	1-a	2-e																								

08. SEK IDC Connectors

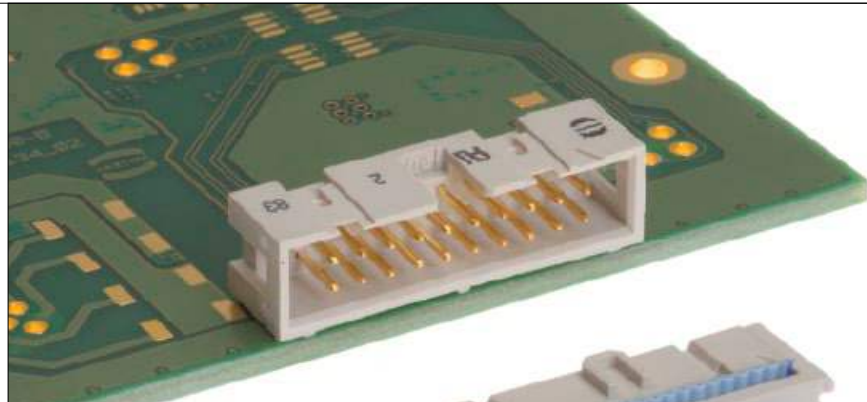

SEK connectors for flat cables enable simple and -, cost-optimized device configuration. SEK connectors are preferably used for connection within the device. HARTING offers a broad range of these cable-to-board connectors.

Assembly on the cable side takes place in one work step for all contacts via flat conductors. The SEK is an economical and reliable interface for data and signal applications in industry.

Application profile:

CONNECTION TYPE		ENVIRONMENT		APPLICATION						
Board to Board	Cable/Wire to Board	IP20	IP65 / IP67	Data	Signal	Power	high performance			
							Data transfer rate	Shielding	Number of contacts, contact density	Voltage, working current
	●	●		●	●				●	
Cable termination			PCB termination			Application standard				
<i>Han-Quick Lock®</i>	<i>IDC</i>	<i>Crimp</i>	<i>THT</i>	<i>SMC</i>	<i>SMT</i>					
	●		●	●						
<i>Screw</i>	<i>Cage clamp</i>	<i>Axial screw</i>	<i>Press-in</i>							
			●							
						<i>Housing integration</i>				
						<i>Separate housing</i>		<i>Integrated housing</i>		

Contents

	Page
SEK connector system – introduction	08.02
General information	08.04
Solder board connectors	08.05
Male standard connectors	08.06
Male low-profile connectors	08.14
Accessories	08.16
Wrap post connectors	
Male standard connectors	08.17
Accessories	08.20
Cable connectors	
Female connectors	08.21
Pcb transition connectors, 2 rows	08.24
Pcb transition connectors, 4 rows	08.28
DIP connectors	08.30
DIN 41 612 connectors	08.32
Press-in connectors	
Male low-profile connectors	08.34
SMC solder board connectors	
Male standard SMC connectors	08.36
Male low-profile SMC connectors	08.46
Accessories	08.48
Cables and cable assemblies	08.49

IDC CONNECTOR SYSTEM [2.54 mm X 2.54 mm PITCH] FOR FLAT CABLES

HARTING's product range of flat cable connectors is designed for various cable-to-PCB applications. The HARTING SEK insulation displacement connector technology meets all requirements of the IEC 60 603-13.

HARTING assembles each SEK connector with the matching cable type according to customer specifications in order to simplify customer installation and storage.

The different types of board connectors offer 6 to 64 pins in various terminations such as solder (manual, wave or reflow) or press-in.

The cable connectors are equally suited for indoor use as well as for outdoor applications and harsh environments.

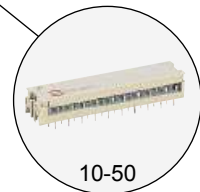
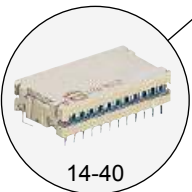
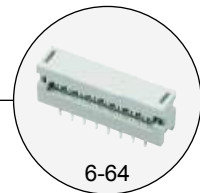
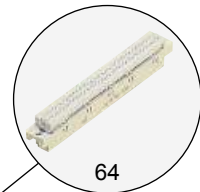
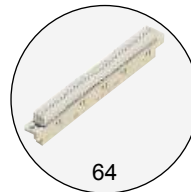
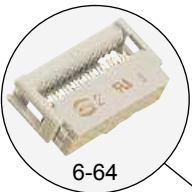

CABLE ASSEMBLIES

- HARTING can supply cable assemblies according to your specifications.
- A wide range of connector types available with various contact arrangements constitute the ideal solution to your wiring problems.
- Cables of all types in economic reel lengths are available.

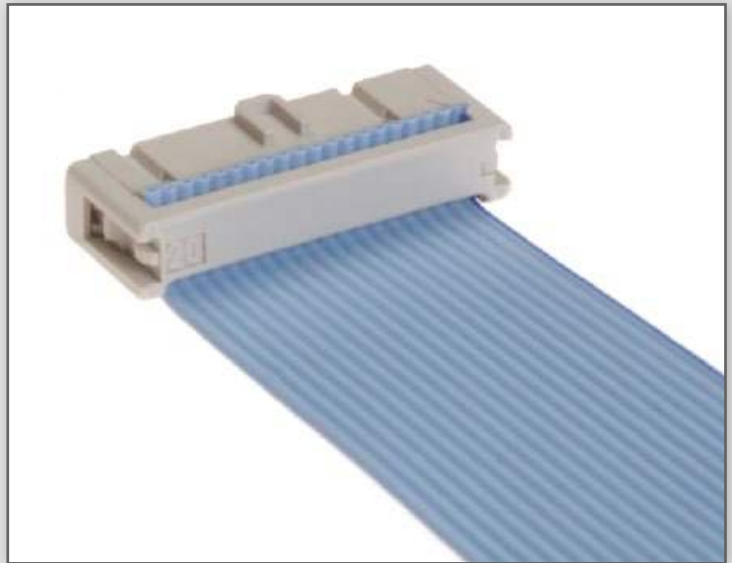

QUALITY

- Cables professionally assembled on HARTING work stations ensure reliable connections.
- Finished harnesses are subject to 100% quality checks on a HARTING test device.
- Insulation test by 1000 V.
- Contact resistance test.

SEK		General information	
<p>Declaration of conformity</p> <p><i>This Declaration of Conformity is available in the German language. Forward order for supplier declaration of conformity.</i></p> <p><i>The basis for the criteria has been found in international documentation, particularly in DIN EN 60903-13. Information on reasons in case of conformity with standards or other technical specifications.</i></p>			
<p>We HARTING KGaA Marienwerder Str. 3 32339 Espelkamp</p>		<p>HARTING Electronics GmbH & Co KG Marienwerder Str. 3 32339 Espelkamp</p>	
<p>Declare under our own responsibility that the Flat Cable Connector System is in conformity with the following standard IEC 60903-13 Connectors for frequencies below 3MHz for use with printed board-Part 13: Detail specification for two-part connectors with assessed quality, for printed boards, for basic grid of 2,54 mm (0,1in) with free connectors for non-accessible insulation displacement termination (ID)</p> <p>This declaration of conformity refers to the series: SEK</p>			
<p> Our testing laboratory is accredited and monitored by the German Accreditation Body Technology (DA-Tech) Reg.-Nr. DAT-P-041/94-02</p>		<p> Our quality system is certified and monitored by DQS in conformity with the standard DIN EN ISO 9001:2000. Cert.-Nr. 002204 QM</p>	
<p>Espekkamp, 2004-11-18 Place and Date of publication</p>		<p> Jörg Sauer Senior Manager of Corporate Technology Services</p>	
<p>Espekkamp, 2004-11-18 Place and Date of publication</p>		<p> H. Schmitt SEK-Ing. Internat. Sales & Service, Global Product Management, HARTING Electronics GmbH & Co KG</p>	

ECONOMY

- The tested assembly of connectors and flat cables from one manufacturer guarantees a high degree of economy and reliability.
- Investments for work stations and test devices are not required.
- Stocks of piece parts are reduced.



The HARTING Insulation Displacement Connector system

Economic and reliable connections

The flat cable and connector can be preassembled and used as a component with predetermined functional characteristics.

The HARTING insulation displacement contacts pierce the insulation on the flat cable to provide a durable gastight connection with the wire.

The HARTING insulation displacement technique constitutes the ideal solution to your wiring problems.

For “non standard applications” we can manufacture designs to match your requirements. Please discuss requirements with us.

HARTING SEK connectors incorporate the latest design features and provide the assurance of high quality and reliability with economy.

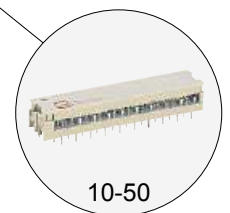
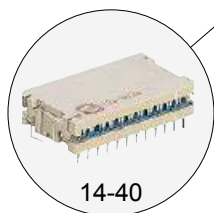
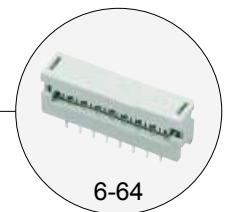
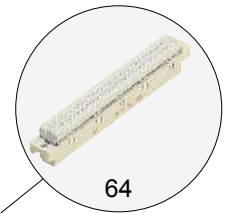
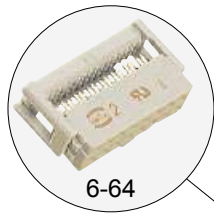

Cable assemblies

- HARTING can supply cable assemblies to customer specifications.
- A wide range of connector types available with various contact arrangements constitute the ideal solution to your wiring problems.
- Cables of all types in economic reel lengths are available.

Quality

- Cables professionally assembled on HARTING work stations ensure reliable connections.
- Finished harnesses are subject to 100% quality checks on a HARTING test device.
- Insulation test.
- Contact resistance test.

Economy

- The tested assembly of connectors and flat cables from one manufacturer guarantees a high degree of economy and reliability.
- Investment for work stations and test devices are not required.
- Stocks of piece parts are reduced.

Number of contacts 6, 10, 14, 16, 20, 24, 26, 30, 34, 40, 50, 60, 64

Contact arrangement straight, angled

Contact length 2.9 mm, 4.5 mm

Approvals IEC 60603-13
DIN EN 60603-13
D 2632
BT 224
NFC 93-428 (HE 10)
UL recognized: E102079



Pitch 2.54 mm [0.100"]

Working current 1 A

Working voltage 500 V
for pollution degree 1

Test voltage $U_{r.m.s.}$ 1 kV

Contact resistance $\leq 20 \text{ m}\Omega$
Insulation resistance $\geq 10^9 \Omega$

Temperature range -55 °C ... +125 °C
The maximum temperature includes heating of contacts and ambient temperature

Terminations For pcb hole $\varnothing 1 \pm 0.1 \text{ mm}$
DIN IEC 52 141
Diagonal: 0.79 mm

Materials Moulding Thermoplastic resin (PBT)
UL 94-V0

Contact surface Contact zone plated according to performance level¹⁾

Current carrying capacity

The current carrying capacity is limited by maximum temperature of materials for inserts and contacts including terminals. The current capacity-curve is valid for continuous, not interrupted current-loaded contacts of connectors when simultaneous power on all contacts is given, without exceeding the maximum temperature.

Control and test procedures according to DIN IEC 60512.

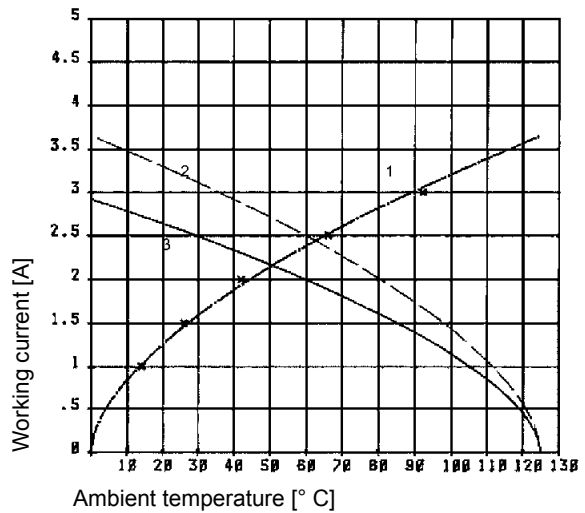

Example: 50 way connector
① Temperature rise
② Derating
③ Derating curve at $I_{max} \times 0.8$ (IEC 60512-2)

Insertion and withdrawal forces

Number of contacts	Maximum force [N]	
	Performance level 1 and 2	Performance level 3
6	12	18
10	20	30
14	28	42
16	32	48
20	40	60
24	48	72
26	52	78
30	60	90
34	68	102
40	80	120
50	100	150
60	120	180
64	128	192

¹⁾ Performance level 3 as per IEC 60603-13, ≥ 50 mating cycles, no gas test
Performance level 2 as per IEC 60603-13, ≥ 250 mating cycles, 4 days gas test
S4, plating = 0.76 μm (30 μinch) Au or PdNi equivalent

Number of contacts

6-64

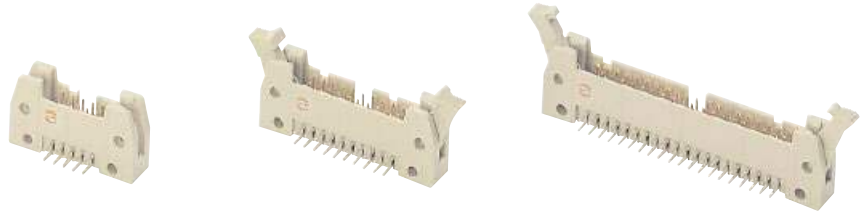

Male header with angled solder pins

Identification	No. of contacts	Part number		
		Without levers	With short levers	With long levers
Male header with angled solder pins Length: 2.9 mm	6	09 18 506 □ 923	09 18 506 □ 913	09 18 506 □ 903
	10	09 18 510 □ 923	09 18 510 □ 913	09 18 510 □ 903
	14	09 18 514 □ 923	09 18 514 □ 913	09 18 514 □ 903
	16	09 18 516 □ 923	09 18 516 □ 913	09 18 516 □ 903
	20	09 18 520 □ 923	09 18 520 □ 913	09 18 520 □ 903
	24	09 18 524 □ 923	09 18 524 □ 913	09 18 524 □ 903
	26	09 18 526 □ 923	09 18 526 □ 913	09 18 526 □ 903
	30	09 18 530 □ 923	09 18 530 □ 913	09 18 530 □ 903
	34	09 18 534 □ 923	09 18 534 □ 913	09 18 534 □ 903
	40	09 18 540 □ 923	09 18 540 □ 913	09 18 540 □ 903
	50	09 18 550 □ 923	09 18 550 □ 913	09 18 550 □ 903
	60	09 18 560 □ 923	09 18 560 □ 913	09 18 560 □ 903
	64	09 18 564 □ 923	09 18 564 □ 913	09 18 564 □ 903
Kinked version on request				
Male header with angled solder pins Length: 4.5 mm	6	09 18 506 □ 921*	09 18 506 □ 911*	09 18 506 □ 901*
	10	09 18 510 □ 921*	09 18 510 □ 911*	09 18 510 □ 901*
	14	09 18 514 □ 921*	09 18 514 □ 911*	09 18 514 □ 901*
	16	09 18 516 □ 921*	09 18 516 □ 911*	09 18 516 □ 901*
	20	09 18 520 □ 921*	09 18 520 □ 911*	09 18 520 □ 901*
	24	09 18 524 □ 921*	09 18 524 □ 911*	09 18 524 □ 901*
	26	09 18 526 □ 921*	09 18 526 □ 911*	09 18 526 □ 901*
	30	09 18 530 □ 921*	09 18 530 □ 911*	09 18 530 □ 901*
	34	09 18 534 □ 921*	09 18 534 □ 911*	09 18 534 □ 901*
	40	09 18 540 □ 921*	09 18 540 □ 911*	09 18 540 □ 901*
	50	09 18 550 □ 921*	09 18 550 □ 911*	09 18 550 □ 901*
	60	09 18 560 □ 921*	09 18 560 □ 911*	09 18 560 □ 901*
	64	09 18 564 □ 921*	09 18 564 □ 911*	09 18 564 □ 901*
Kinked version on request				

SEK

08
06

* Not normally kept in stock
For accessories see page 08.16
For dimensions see page 08.07

For performance level 3 please specify digit 7*
For performance level 2 please specify digit 6*
S4 = 0.76 µm (30 µinch) Au or PdNi equivalent 5*



Number of contacts

6-64

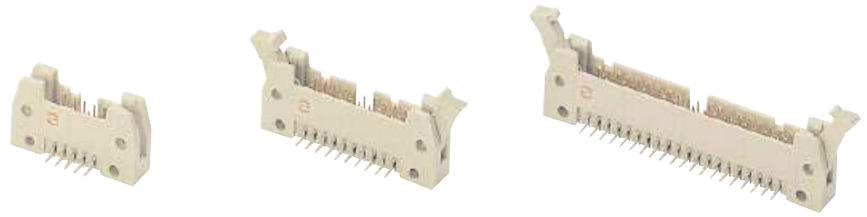

Male header with angled solder pins

Identification

Drawing

Dimensions in mm

Male header

No. of contacts	A	B	D	E	F	G
6	26.9	16.76	12.45	2.54 x 2 = 5.08	36.9	40.3
10	32.0	21.84	17.53	2.54 x 4 = 10.16	42.0	45.4
14	37.1	26.92	22.61	2.54 x 6 = 15.24	47.1	50.4
16	39.6	29.46	25.15	2.54 x 7 = 17.78	49.6	53.0
20	44.7	34.54	30.23	2.54 x 9 = 22.86	54.7	58.1
24	49.8	39.62	35.91	2.54 x 11 = 27.94	59.8	63.2
26	52.3	42.16	37.85	2.54 x 12 = 30.48	62.3	65.7
30	57.7	47.24	43.83	2.54 x 14 = 35.56	68.2	68.6
34	62.5	52.32	48.01	2.54 x 16 = 40.64	72.5	75.8
40	70.1	59.94	55.63	2.54 x 19 = 48.26	80.1	83.5
50	82.8	72.64	68.33	2.54 x 24 = 60.96	92.8	96.2
60	95.5	85.34	81.03	2.54 x 29 = 73.66	105.5	108.9
64	100.6	90.42	86.11	2.54 x 31 = 78.74	110.6	113.9

Short levers

for use with female connector without strain relief clamp

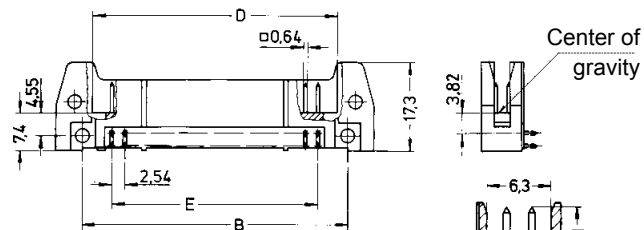

Long levers

for use with female connector with strain relief clamp

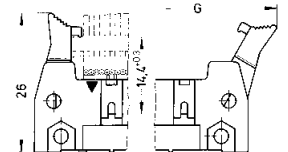
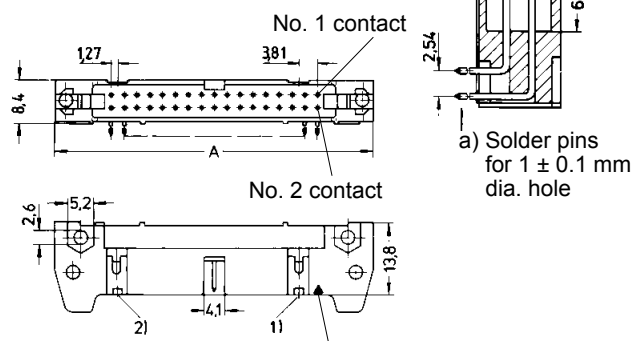

Board drillings

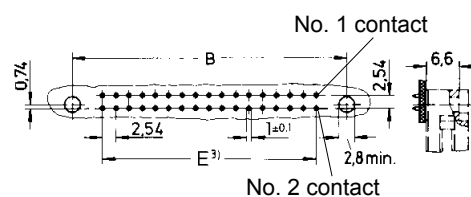

Number of contacts

6-64

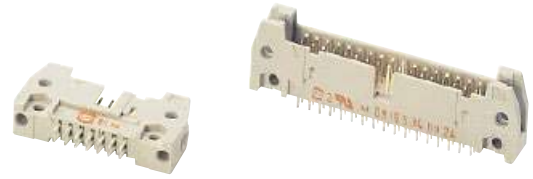

Male header with straight solder pins

Identification	No. of contacts	Part number		
		Without levers	With short levers	With long levers
Male header with straight solder pins Length: 2.9 mm	6	09 18 506 □ 924	09 18 506 □ 914	09 18 506 □ 904
	10	09 18 510 □ 924	09 18 510 □ 914	09 18 510 □ 904
	14	09 18 514 □ 924	09 18 514 □ 914	09 18 514 □ 904
	16	09 18 516 □ 924	09 18 516 □ 914	09 18 516 □ 904
	20	09 18 520 □ 924	09 18 520 □ 914	09 18 520 □ 904
	24	09 18 524 □ 924	09 18 524 □ 914	09 18 524 □ 904
	26	09 18 526 □ 924	09 18 526 □ 914	09 18 526 □ 904
	30	09 18 530 □ 924	09 18 530 □ 914	09 18 530 □ 904
	34	09 18 534 □ 924	09 18 534 □ 914	09 18 534 □ 904
	40	09 18 540 □ 924	09 18 540 □ 914	09 18 540 □ 904
	50	09 18 550 □ 924	09 18 550 □ 914	09 18 550 □ 904
	60	09 18 560 □ 924	09 18 560 □ 914	09 18 560 □ 904
	64	09 18 564 □ 924	09 18 564 □ 914	09 18 564 □ 904
	Male header with straight solder pins Length: 4.5 mm	6	09 18 506 □ 922*	09 18 506 □ 912*
10		09 18 510 □ 922*	09 18 510 □ 912*	09 18 510 □ 902*
14		09 18 514 □ 922*	09 18 514 □ 912*	09 18 514 □ 902*
16		09 18 516 □ 922*	09 18 516 □ 912*	09 18 516 □ 902*
20		09 18 520 □ 922*	09 18 520 □ 912*	09 18 520 □ 902*
24		09 18 524 □ 922*	09 18 524 □ 912*	09 18 524 □ 902*
26		09 18 526 □ 922*	09 18 526 □ 912*	09 18 526 □ 902*
30		09 18 530 □ 922*	09 18 530 □ 912*	09 18 530 □ 902*
34		09 18 534 □ 922*	09 18 534 □ 912*	09 18 534 □ 902*
40		09 18 540 □ 922*	09 18 540 □ 912*	09 18 540 □ 902*
50		09 18 550 □ 922*	09 18 550 □ 912*	09 18 550 □ 902*
60		09 18 560 □ 922*	09 18 560 □ 912*	09 18 560 □ 902*
64		09 18 564 □ 922*	09 18 564 □ 912*	09 18 564 □ 902*

SEK

08
08

Kinked version on request

* Not normally kept in stock
For accessories see page 08.16
For dimensions see page 08.09

For performance level 3 please specify digit 7*
For performance level 2 please specify digit 6*
S4 = 0.76 µm (30 µinch) Au or PdNi equivalent 5*



Number of contacts

6-64

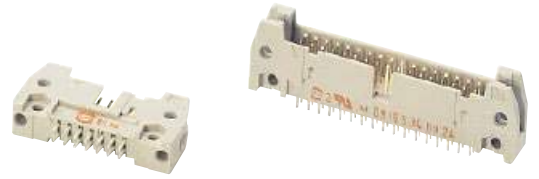

Male header with straight solder pins

Identification

Drawing

Dimensions in mm

Male header

No. of contacts	A	C	D	E	F	G
6	26.9	22.86	12.45	2.54 x 2 = 5.08	36.9	40.3
10	32.0	27.94	17.53	2.54 x 4 = 10.16	42.0	45.4
14	37.1	33.02	22.61	2.54 x 6 = 15.24	47.1	50.4
16	39.6	35.56	25.15	2.54 x 7 = 17.78	49.6	53.0
20	44.7	40.64	30.23	2.54 x 9 = 22.86	54.7	58.1
24	49.8	45.72	35.91	2.54 x 11 = 27.94	59.8	63.2
26	52.3	48.26	37.85	2.54 x 12 = 30.48	62.3	65.7
30	57.7	53.34	43.83	2.54 x 14 = 35.56	68.2	68.6
34	62.5	58.42	48.01	2.54 x 16 = 40.64	72.5	75.8
40	70.1	66.04	55.63	2.54 x 19 = 48.26	80.1	83.5
50	82.8	78.74	68.33	2.54 x 24 = 60.96	92.8	96.2
60	95.5	91.44	81.03	2.54 x 29 = 73.66	105.5	108.9
64	100.6	96.52	86.11	2.54 x 31 = 78.74	110.6	113.9

Short levers

for use with female connector without strain relief clamp

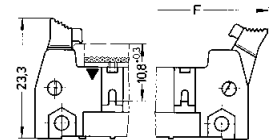
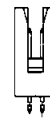
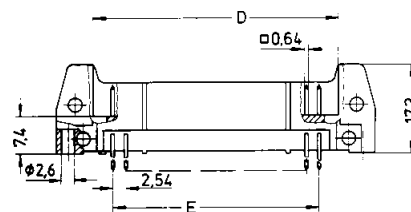

Long levers

for use with female connector with strain relief clamp

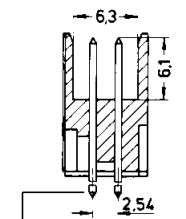
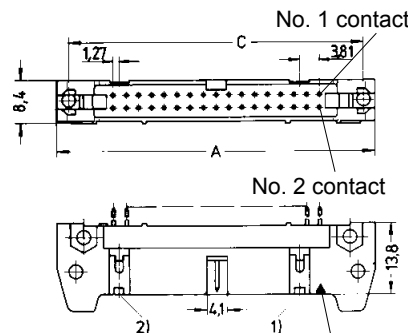

a) Solder pins for 1 ± 0.1 mm dia. hole

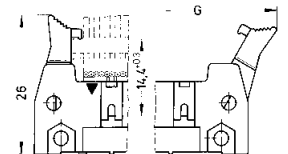

Marking No. 1 contact

No. 1 contact

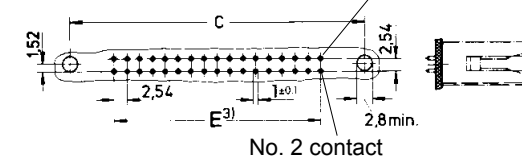

Board drillings

Number of contacts

6-64

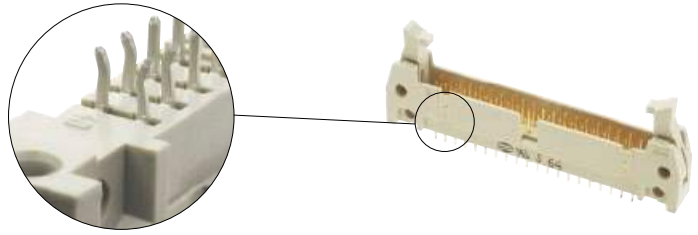

Male header with straight solder pins, kinked

Identification	No. of contacts	Part number		
		Without levers	With short levers	With long levers
Male header with straight solder pins, kinked Length: 2.9 mm				
	6	09 18 506 □ 024	09 18 506 □ 014	09 18 506 □ 004
	10	09 18 510 □ 024	09 18 510 □ 014	09 18 510 □ 004
	14	09 18 514 □ 024	09 18 514 □ 014	09 18 514 □ 004
	16	09 18 516 □ 024	09 18 516 □ 014	09 18 516 □ 004
	20	09 18 520 □ 024	09 18 520 □ 014	09 18 520 □ 004
	24	09 18 524 □ 024	09 18 524 □ 014	09 18 524 □ 004
	26	09 18 526 □ 024	09 18 526 □ 014	09 18 526 □ 004
	30	09 18 530 □ 024	09 18 530 □ 014	09 18 530 □ 004
	34	09 18 534 □ 024	09 18 534 □ 014	09 18 534 □ 004
	40	09 18 540 □ 024	09 18 540 □ 014	09 18 540 □ 004
	50	09 18 550 □ 024	09 18 550 □ 014	09 18 550 □ 004
	60	09 18 560 □ 024	09 18 560 □ 014	09 18 560 □ 004
	64	09 18 564 □ 024	09 18 564 □ 014	09 18 564 □ 004

SEK

* Not normally kept in stock
For accessories see page 08.16
For dimensions see page 08.11

For performance level 3 please specify digit 7*
For performance level 2 please specify digit 6*
S4 = 0.76 µm (30 µinch) Au or PdNi equivalent



Number of contacts

6-64

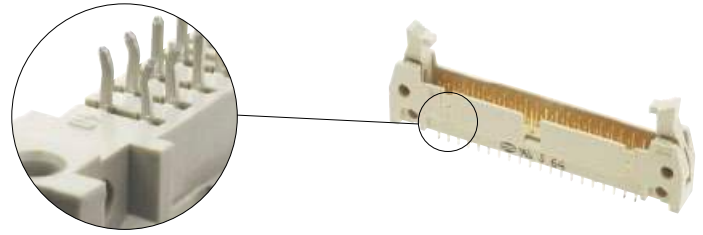

Male header with straight solder pins, kinked

Identification

Drawing

Dimensions in mm

Male header

No. of contacts	A	C	D	E	F	G
6	26.9	22.86	12.45	2.54 x 2 = 5.08	36.9	40.3
10	32.0	27.94	17.53	2.54 x 4 = 10.16	42.0	45.4
14	37.1	33.02	22.61	2.54 x 6 = 15.24	47.1	50.4
16	39.6	35.56	25.15	2.54 x 7 = 17.78	49.6	53.0
20	44.7	40.64	30.23	2.54 x 9 = 22.86	54.7	58.1
24	49.8	45.72	35.91	2.54 x 11 = 27.94	59.8	63.2
26	52.3	48.26	37.85	2.54 x 12 = 30.48	62.3	65.7
30	57.7	53.34	43.83	2.54 x 14 = 35.56	68.2	68.6
34	62.5	58.42	48.01	2.54 x 16 = 40.64	72.5	75.8
40	70.1	66.04	55.63	2.54 x 19 = 48.26	80.1	83.5
50	82.8	78.74	68.33	2.54 x 24 = 60.96	92.8	96.2
60	95.5	91.44	81.03	2.54 x 29 = 73.66	105.5	108.9
64	100.6	96.52	86.11	2.54 x 31 = 78.74	110.6	113.9

Short levers

for use with female connector without strain relief clamp

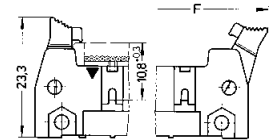
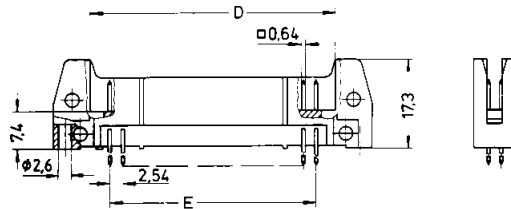

Long levers

for use with female connector with strain relief clamp

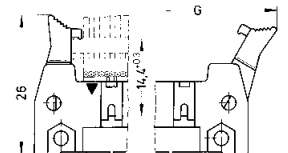
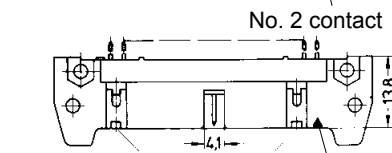
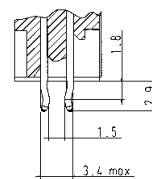
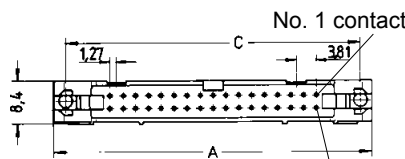

Marking No. 1 contact

No. 1 contact

Board drillings

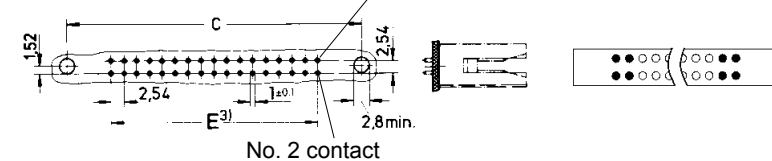

● Kinked contact: pcb thickness from 1.50 to 1.94 mm after Cu + Sn plating with non-remelted through holes \varnothing 0.80 to \varnothing 0.95 mm. Max. insertion force = 125 N. Min. retention force = 3 N.

○ Non-kinked contact: Solder pins for pcb connections \varnothing 1 ± 0.1 mm as per IEC 60603-13.

Number of contacts

6-64

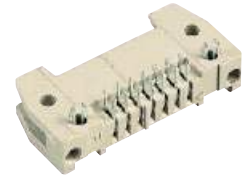

Male header with angled solder pins and board lock

Identification	No. of contacts	Part number		
		Without levers	With short levers	With long levers
<p>Male header with angled solder pins and pcb board lock</p> <p>Length: 2.9 mm for 1.6 mm pcb thickness</p> <p>To hold the connector on the pcb before the soldering process, two board locks have been added on the male header with angled solder pins.</p>	6	09 18 506 □ 973*	09 18 506 □ 963*	09 18 506 □ 953*
	10	09 18 510 □ 973*	09 18 510 □ 963*	09 18 510 □ 953*
	14	09 18 514 □ 973*	09 18 514 □ 963*	09 18 514 □ 953*
	16	09 18 516 □ 973*	09 18 516 □ 963*	09 18 516 □ 953*
	20	09 18 520 □ 973*	09 18 520 □ 963*	09 18 520 □ 953*
	24	09 18 524 □ 973*	09 18 524 □ 963*	09 18 524 □ 953*
	26	09 18 526 □ 973*	09 18 526 □ 963*	09 18 526 □ 953*
	30	09 18 530 □ 973*	09 18 530 □ 963*	09 18 530 □ 953*
	34	09 18 534 □ 973*	09 18 534 □ 963*	09 18 534 □ 953*
	40	09 18 540 □ 973*	09 18 540 □ 963*	09 18 540 □ 953*
	50	09 18 550 □ 973*	09 18 550 □ 963*	09 18 550 □ 953*
	60	09 18 560 □ 973*	09 18 560 □ 963*	09 18 560 □ 953*
	64	09 18 564 □ 973*	09 18 564 □ 963*	09 18 564 □ 953*

SEK

* Not normally kept in stock

For performance level 3 please specify digit 7
 For performance level 2 please specify digit 6
 S4 = 0.76 µm (30 µinch) Au or PdNi equivalent 5

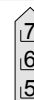
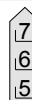

Number of contacts

6-64

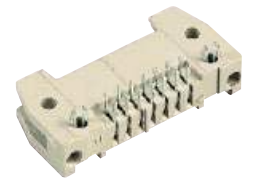

Male header with angled solder pins and board lock

Identification

Drawing

Dimensions in mm

Male header

No. of contacts	A	B	D	E	F	G
6	26.9	16.76	12.45	2.54 x 2 = 5.08	36.9	40.3
10	32.0	21.84	17.53	2.54 x 4 = 10.16	42.0	45.4
14	37.1	26.92	22.61	2.54 x 6 = 15.24	47.1	50.4
16	39.6	29.46	25.15	2.54 x 7 = 17.78	49.6	53.0
20	44.7	34.54	30.23	2.54 x 9 = 22.86	54.7	58.1
24	49.8	39.62	35.91	2.54 x 11 = 27.94	59.8	63.2
26	52.3	42.16	37.85	2.54 x 12 = 30.48	62.3	65.7
30	57.7	47.24	43.83	2.54 x 14 = 35.56	68.2	68.6
34	62.5	52.32	48.01	2.54 x 16 = 40.64	72.5	75.8
40	70.1	59.94	55.63	2.54 x 19 = 48.26	80.1	83.5
50	82.8	72.64	68.33	2.54 x 24 = 60.96	92.8	96.2
60	95.5	85.34	81.03	2.54 x 29 = 73.66	105.5	108.9
64	100.6	90.42	86.11	2.54 x 31 = 78.74	110.6	113.9

Short levers

for use with female connector without strain relief clamp

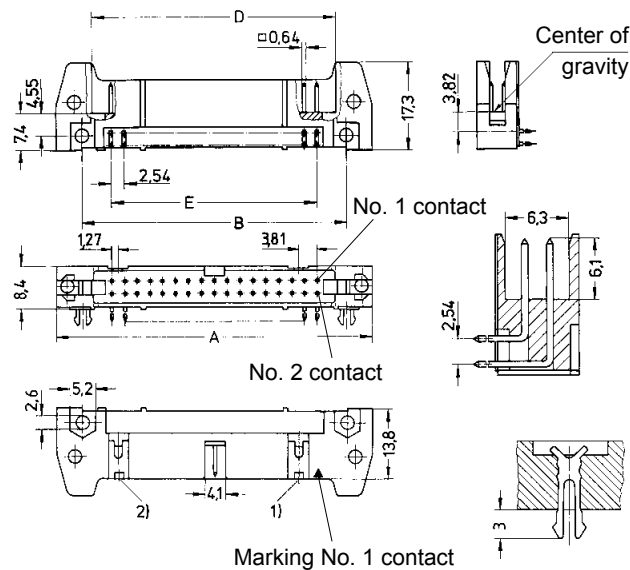

Long levers

for use with female connector with strain relief clamp

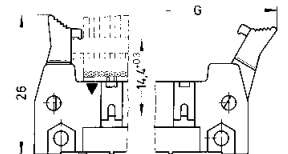

Board drillings

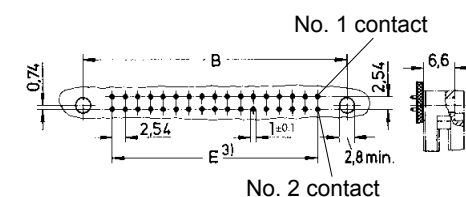

For accessories see page 08.16

1) No polarization slot for 6, 10 or 14 way male header

2) No polarization slot for 6 way male header

3) Pitch tolerance: ± 0.1

Number of contacts

6-64

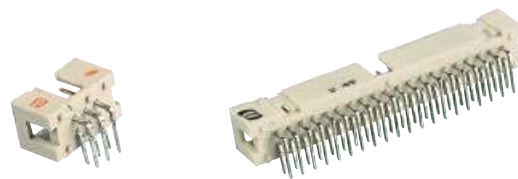

Low-profile male header, angled solder pins

Identification	No. of contacts	Part number	Drawing	Dimensions in mm
----------------	-----------------	-------------	---------	------------------

Male header with angled solder pins

Length: 2.9 mm

6	09 18 506	□ 323
10	09 18 510	□ 323
14	09 18 514	□ 323
16	09 18 516	□ 323
20	09 18 520	□ 323
26	09 18 526	□ 323
30	09 18 530	□ 323
34	09 18 534	□ 323
40	09 18 540	□ 323
50	09 18 550	□ 323
60	09 18 560	□ 323
64	09 18 564	□ 323

No. of contacts	A	B	E
6	15.2	12.78	2.54 x 2 = 5.08
10	20.3	17.86	2.54 x 4 = 10.16
14	25.4	22.94	2.54 x 6 = 15.24
16	27.9	25.48	2.54 x 7 = 17.78
20	33.0	30.56	2.54 x 9 = 22.86
26	40.6	38.18	2.54 x 12 = 30.48
30	45.72	43.26	2.54 x 14 = 35.56
34	50.8	48.34	2.54 x 16 = 40.64
40	58.4	55.96	2.54 x 19 = 48.26
50	71.3	68.66	2.54 x 24 = 60.96
60	84.0	81.36	2.54 x 29 = 73.66
64	89.1	86.44	2.54 x 31 = 78.74

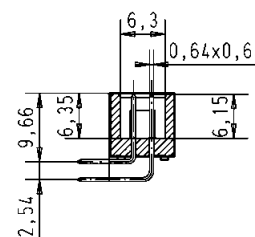

Solder pins for 1 ± 0.1 mm dia. hole

Marking No. 1 contact

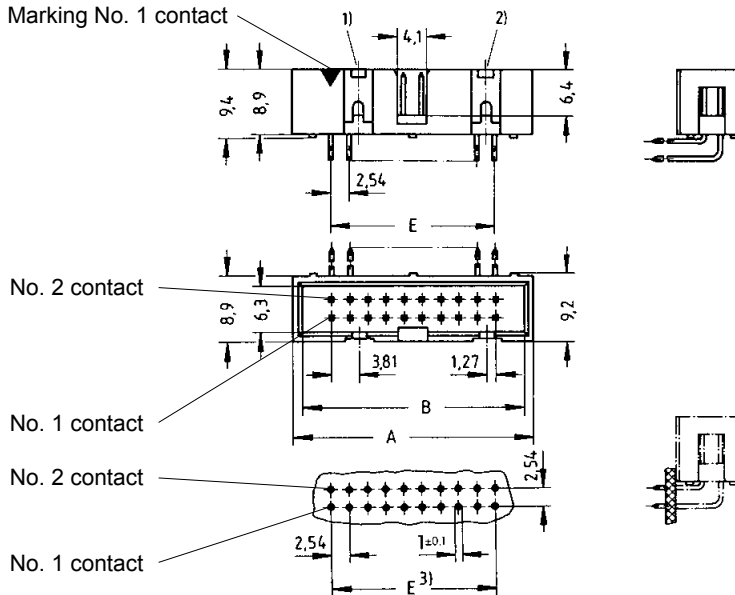

For performance level 3 please specify digit 7
 For performance level 2 please specify digit 6
 S4 = 0.76 µm (30 µinch) Au or PdNi equivalent



Identification	Part number	Drawing	Dimensions in mm
----------------	-------------	---------	------------------

Locking lever for female connector with strain relief

in conjunction with low-profile male header

When the security of latching is required and space is a premium, these locking levers can be fitted onto the strain relief of the HARTING female connector.

09 18 000 9905⁴⁾

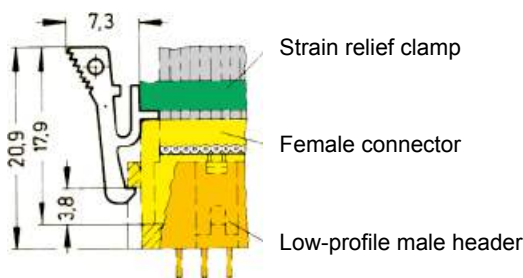

* Not normally kept in stock

¹⁾ No polarization slot for 6, 10 or 14 way male header
²⁾ No polarization slot for 6 way male header

³⁾ Pitch tolerance: ± 0.1
⁴⁾ Order 2 per female connector

Number of contacts

6-64



Low-profile male header, straight solder pins

Identification	No. of contacts	Part number	Drawing	Dimensions in mm
----------------	-----------------	-------------	---------	------------------

Male header with straight solder pins
Length: 2.9 mm

6	09 18 506	□ 324
10	09 18 510	□ 324
14	09 18 514	□ 324
16	09 18 516	□ 324
20	09 18 520	□ 324
26	09 18 526	□ 324
30	09 18 530	□ 324
34	09 18 534	□ 324
40	09 18 540	□ 324
50	09 18 550	□ 324
60	09 18 560	□ 324
64	09 18 564	□ 324

No. of contacts	A	B	E
6	15.2	12.78	2.54 x 2 = 5.08
10	20.3	17.86	2.54 x 4 = 10.16
14	25.4	22.94	2.54 x 6 = 15.24
16	27.9	25.48	2.54 x 7 = 17.78
20	33.0	30.56	2.54 x 9 = 22.86
26	40.6	38.18	2.54 x 12 = 30.48
30	45.72	43.26	2.54 x 14 = 35.56
34	50.8	48.34	2.54 x 16 = 40.64
40	58.4	55.96	2.54 x 19 = 48.26
50	71.3	68.66	2.54 x 24 = 60.96
60	84.0	81.36	2.54 x 29 = 73.66
64	89.1	86.44	2.54 x 31 = 78.74

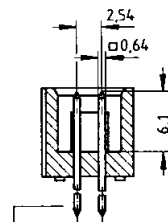

Solder pins for 1 ± 0.1 mm dia. hole

Male header with straight solder pins
Length: 4.5 mm

6	09 18 506	□ 322*
10	09 18 510	□ 322*
14	09 18 514	□ 322*
16	09 18 516	□ 322*
20	09 18 520	□ 322*
26	09 18 526	□ 322*
30	09 18 530	□ 322*
34	09 18 534	□ 322*
40	09 18 540	□ 322*
50	09 18 550	□ 322*
60	09 18 560	□ 322*
64	09 18 564	□ 322*

Marking No. 1 contact

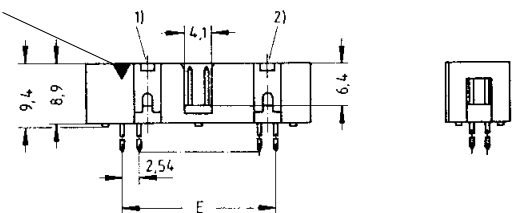

No. 2 contact

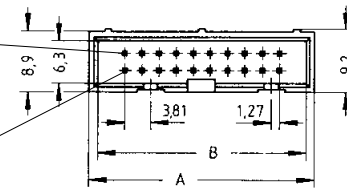

No. 1 contact

No. 2 contact

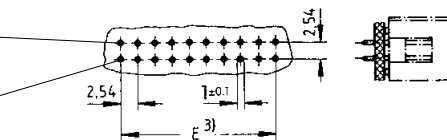

For performance level 3 please specify digit 7
For performance level 2 please specify digit 6
S4 = 0.76 µm (30 µinch) Au or PdNi equivalent



Identification	Part number	Drawing	Dimensions in mm
----------------	-------------	---------	------------------

Locking lever for female connector with strain relief
in conjunction with low-profile male header

When the security of latching is required and space is a premium, these locking levers can be fitted onto the strain relief of the HARTING female connector.

09 18 000 9905⁴⁾

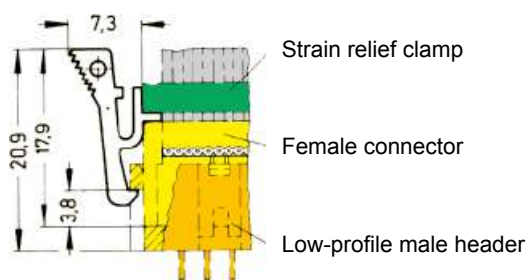

* Not normally kept in stock

¹⁾ No polarization slot for 6, 10 or 14 way male header
²⁾ No polarization slot for 6 way male header

³⁾ Pitch tolerance: ± 0.1
⁴⁾ Order 2 per female connector

Accessories

Identification	Part number	Drawing	Dimensions in mm
<p>Polarization key</p> <p>1) Part number comprises 2 keys</p>	<p>09 18 500 9902¹⁾</p>		
<p>Locking lever (snaps into place, can be fitted whenever required)</p> <p>2) Order 2 per male header</p>	<p>Long: 09 18 000 9903²⁾</p> <p>Short: 09 18 000 9904²⁾</p>	<p>Long</p> <p>Short</p> <p>For use with female connector <u>with</u> strain relief clamp</p> <p>For use with female connector <u>without</u> strain relief clamp</p>	
<p>Fixing screws for 1.6 mm P.C. board</p> <p>3) Part number comprises 50 pieces</p>	<p>09 18 000 9906³⁾</p>	<p>BZ 2.9x6.5 (DIN 7981 or DIN 7049)</p>	<p>For connectors with part numbers 09 18 5xx x9xx: screwing torque 0.2 Nm 09 19 5xx x9xx: screwing torque 0.4 – 0.5 Nm</p> <p>Screw material: Steel (Inox A2)</p> <p>Plating: Nickel</p>
<p>Coding system with loss of contact</p> <p>4) Part number comprises 6 code pins</p>	<p>Code pin 09 18 000 9901⁴⁾</p> <p>Removal tool for male contacts 09 99 000 0133</p>	<p>To avoid cross-plugging adjacent connectors a coding system is required. A code pin is inserted into the appropriate cavity in the female connector. The corresponding male contact is removed by a special removal tool.</p>	

SEK

Number of contacts	6, 10, 14, 16, 20, 24, 26, 30, 34, 40, 50, 60, 64	
Contact arrangement	straight, angled	
Contact length	15 mm	
Approvals	IEC 60603-13 DIN EN 60603-13 D 2632 BT 224 NFC 93-428 (HE 10)	
Pitch	2.54 mm [0.100"]	
Working current	1 A	
Working voltage	500 V for pollution degree 1	
Test voltage $U_{r.m.s.}$	1 kV	
Contact resistance Insulation resistance	$\leq 20 \text{ m}\Omega$ $\geq 10^9 \Omega$	
Temperature range	-55 °C ... +125 °C The maximum temperature includes heating of contacts and ambient temperature	
Terminations	0.6 mm x 0.6 mm Diagonal: 0.86 mm	
Materials Moulding	Thermoplastic resin (PBT) UL 94-V0	
Contact surface Contact zone	plated according to performance level ¹⁾	

SEK

¹⁾ Performance level 3 as per IEC 60603-13, ≥ 50 mating cycles, no gas test
Performance level 2 as per IEC 60603-13, ≥ 250 mating cycles, 4 days gas test
S4, plating = 0.76 μm (30 μinch) Au or PdNi equivalent

Number of contacts

6-64



Male header with wrap posts

Identification	No. of contacts	Part number		
		Without levers	With short levers	With long levers
Male header with angled wrap posts Length: 15 mm <input type="checkbox"/> 0.6 mm	6	09 18 506 □ 926*	09 18 506 □ 916*	09 18 506 □ 906*
	10	09 18 510 □ 926*	09 18 510 □ 916*	09 18 510 □ 906*
	14	09 18 514 □ 926*	09 18 514 □ 916*	09 18 514 □ 906*
	16	09 18 516 □ 926*	09 18 516 □ 916*	09 18 516 □ 906*
	20	09 18 520 □ 926*	09 18 520 □ 916*	09 18 520 □ 906*
	24	09 18 524 □ 926*	09 18 524 □ 916*	09 18 524 □ 906*
	26	09 18 526 □ 926*	09 18 526 □ 916*	09 18 526 □ 906*
	30	09 18 530 □ 926*	09 18 530 □ 916*	09 18 530 □ 906*
	34	09 18 534 □ 926*	09 18 534 □ 916*	09 18 534 □ 906*
	40	09 18 540 □ 926*	09 18 540 □ 916*	09 18 540 □ 906*
	50	09 18 550 □ 926*	09 18 550 □ 916*	09 18 550 □ 906*
	60	09 18 560 □ 926*	09 18 560 □ 916*	09 18 560 □ 906*
	64	09 18 564 □ 926*	09 18 564 □ 916*	09 18 564 □ 906*
	Male header with straight wrap posts Length: 15 mm <input type="checkbox"/> 0.6 mm	6	09 18 506 □ 927*	09 18 506 □ 917*
10		09 18 510 □ 927*	09 18 510 □ 917*	09 18 510 □ 907*
14		09 18 514 □ 927*	09 18 514 □ 917*	09 18 514 □ 907*
16		09 18 516 □ 927*	09 18 516 □ 917*	09 18 516 □ 907*
20		09 18 520 □ 927*	09 18 520 □ 917*	09 18 520 □ 907*
24		09 18 524 □ 927*	09 18 524 □ 917*	09 18 524 □ 907*
26		09 18 526 □ 927*	09 18 526 □ 917*	09 18 526 □ 907*
30		09 18 530 □ 927*	09 18 530 □ 917*	09 18 530 □ 907*
34		09 18 534 □ 927*	09 18 534 □ 917*	09 18 534 □ 907*
40		09 18 540 □ 927*	09 18 540 □ 917*	09 18 540 □ 907*
50		09 18 550 □ 927*	09 18 550 □ 917*	09 18 550 □ 907*
60		09 18 560 □ 927*	09 18 560 □ 917*	09 18 560 □ 907*
64		09 18 564 □ 927*	09 18 564 □ 917*	09 18 564 □ 907*

SEK

* Not normally kept in stock
 For accessories see page 08.20
 For dimensions see page 08.19

For performance level 3 please specify digit 7
 For performance level 2 please specify digit 6
 S4 = 0.76 µm (30 µinch) Au or PdNi equivalent

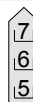

Number of contacts

6-64



Male header with wrap posts

Identification

Drawing

Dimensions in mm

Male header

No. of contacts	A	B	C	D	E	F	G
6	26.9	16.76	22.86	12.45	2.54 x 2 = 5.08	36.9	40.3
10	32.0	21.84	27.94	17.53	2.54 x 4 = 10.16	42.0	45.4
14	37.1	26.92	33.02	22.61	2.54 x 6 = 15.24	47.1	50.4
16	39.6	29.46	35.56	25.15	2.54 x 7 = 17.78	49.6	53.0
20	44.7	34.54	40.64	30.23	2.54 x 9 = 22.86	54.7	58.1
24	49.8	39.62	45.72	35.91	2.54 x 11 = 27.94	59.8	63.2
26	52.3	42.16	48.26	37.85	2.54 x 12 = 30.48	62.3	65.7
30	57.7	47.24	53.43	43.83	2.54 x 14 = 35.56	68.2	68.6
34	62.5	52.32	58.42	48.01	2.54 x 16 = 40.64	72.5	75.8
40	70.1	59.94	66.04	55.63	2.54 x 19 = 48.26	80.1	83.5
50	82.8	72.64	78.74	68.33	2.54 x 24 = 60.96	92.8	96.2
60	95.5	85.34	91.44	81.03	2.54 x 29 = 73.66	105.5	108.9
64	100.6	90.42	96.52	86.11	2.54 x 31 = 78.74	110.6	113.9

Long levers

for use with female connector with strain relief clamp

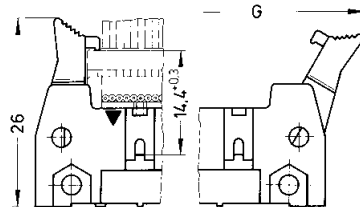

Short levers

for use with female connector without strain relief clamp

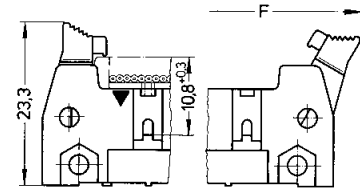

Angled versions

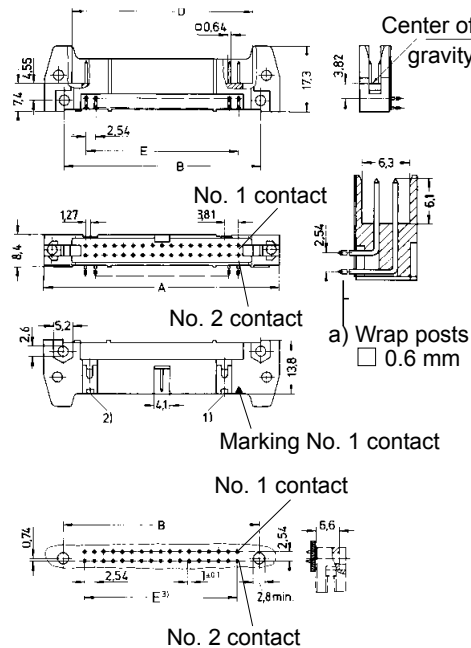

Straight versions

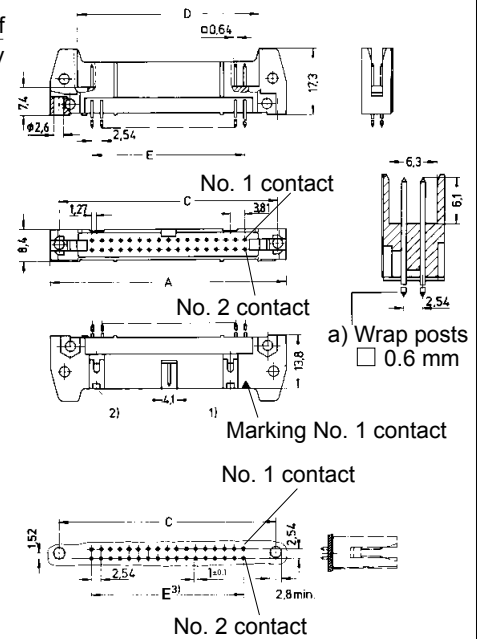

Board drillings

For accessories see page 08.20

¹⁾ No polarization slot for 6, 10 or 14 way male header

²⁾ No polarization slot for 6 way male header

³⁾ Pitch tolerance: ± 0.1

Accessories

Identification	Part number	Drawing	Dimensions in mm
<p>Polarization key</p> <p>1) Part number comprises 2 keys</p>	<p>09 18 500 9902¹⁾</p>		
<p>Locking lever (snaps into place, can be fitted whenever required)</p> <p>2) Order 2 per male header</p>	<p>Long: 09 18 000 9903²⁾</p> <p>Short: 09 18 000 9904²⁾</p>	<p>Long</p> <p>Short</p> <p>For use with female connector <u>with</u> strain relief clamp</p> <p>For use with female connector <u>without</u> strain relief clamp</p>	
<p>Fixing screws for 1.6 mm P.C. board</p> <p>3) Part number comprises 50 pieces</p>	<p>09 18 000 9906³⁾</p>	<p>BZ 2.9x6.5 (DIN 7981 or DIN 7049)</p> <p>For connectors with part numbers 09 18 5xx x9xx: screwing torque 0.2 Nm 09 19 5xx x9xx: screwing torque 0.4 – 0.5 Nm</p> <p>Screw material: Steel (Inox A2)</p> <p>Plating: Nickel</p>	
<p>Coding system with loss of contact</p> <p>4) Part number comprises 6 code pins</p>	<p>Code pin</p> <p>09 18 000 9901⁴⁾</p> <p>Removal tool for male contacts</p> <p>09 99 000 0133</p>	<p>To avoid cross-plugging adjacent connectors a coding system is required. A code pin is inserted into the appropriate cavity in the female connector. The corresponding male contact is removed by a special removal tool.</p>	

SEK

Number of contacts 6, 10, 14, 16, 20, 24, 26, 30, 34, 40, 50, 60, 64

Approvals IEC 60603-13
DIN EN 60603-13
D 2632
BT 224
NFC 93-428 (HE 10)
UL recognized: E102079



Pitch On pcb side: 2.54 mm [0.100"]
On cable side: 1.27 mm [0.050"]

Rated current 2.5 A min. at ambient temperature of 30 °C

Working voltage 320 V for pollution degree 1

Test voltage $U_{r.m.s.}$ 1 kV

Contact resistance $\leq 20 \text{ m}\Omega$
Insulation resistance $\geq 10^9 \Omega$

Temperature range -55 °C ... +125 °C
The maximum temperature includes heating of contacts and ambient temperature

Terminations IDC flat cable
1.27 mm [0.050"] pitch:
AWG 26/7 – AWG 28/7

Materials Moulding Thermoplastic resin (PBT) UL 94-V0

Contact surface Contact zone gold-plated according to performance level¹⁾

Current carrying capacity

The current carrying capacity is limited by maximum temperature of materials for inserts and contacts including terminals. The current capacity-curve is valid for continuous, not interrupted current-loaded contacts of connectors when simultaneous power on all contacts is given, without exceeding the maximum temperature.

Control and test procedures according to IEC 60512.

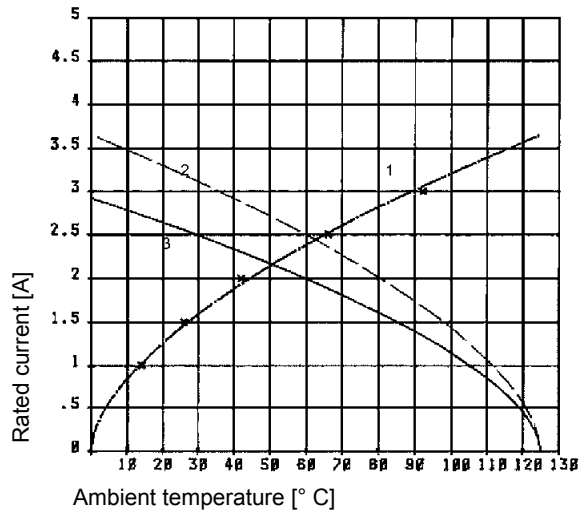

Example: 50 way connector

- ① Temperature rise
- ② Derating
- ③ Derating curve at $I_{max.} \times 0.8$ (IEC 60512-2)

Insertion and withdrawal forces

Number of contacts	Maximum force [N]	
	Performance level 1 and 2	Performance level 3
6	12	18
10	20	30
14	28	42
16	32	48
20	40	60
24	48	72
26	52	78
30	60	90
34	68	102
40	80	120
50	100	150
60	120	180
64	128	192



¹⁾ Performance level 3 as per IEC 60603-13, ≥ 50 mating cycles, no gas test
Performance level 2 as per IEC 60603-13, ≥ 250 mating cycles, 4 days gas test
S4, plating = 0.76 μm (30 μinch) Au or PdNi equivalent

Number of contacts

6-64

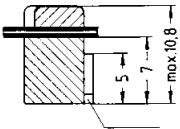
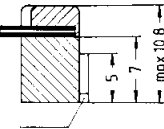
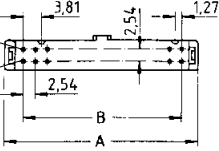
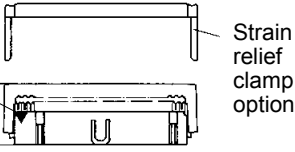
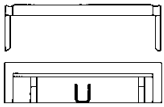

Female connector

Identification	No. of contacts	Part number		Drawing	Dimensions in mm																																				
Female connector with central polarization without strain relief clamp 		open end cover	closed end cover	open end cover	closed end cover																																				
	6	09 18 506 □ 803	09 18 506 □ 804																																						
	10	09 18 510 □ 803	09 18 510 □ 804	option																																					
	14	09 18 514 □ 803	09 18 514 □ 804																																						
	16	09 18 516 □ 803	09 18 516 □ 804																																						
	20	09 18 520 □ 803	09 18 520 □ 804																																						
	24	09 18 524 □ 803	09 18 524 □ 804																																						
	26	09 18 526 □ 803	09 18 526 □ 804																																						
	30	09 18 530 □ 803	09 18 530 □ 804																																						
	34	09 18 534 □ 803	09 18 534 □ 804																																						
	40	09 18 540 □ 803	09 18 540 □ 804																																						
	50	09 18 550 □ 803	09 18 550 □ 804																																						
	60	09 18 560 □ 803	09 18 560 □ 804																																						
	64	09 18 564 □ 803	09 18 564 □ 804																																						
	without strain relief clamp with bulk packaging 2) Packaging unit (PU) 5,000 pieces 3) PU 3,000 pieces	6	09 18 506 □ 803 58U ²⁾		No. 1 contact No. 2 contact 	Strain relief clamp option 																																			
		10	09 18 510 □ 803 58U ²⁾																																						
		14	09 18 514 □ 803 58U ²⁾																																						
		16	09 18 516 □ 803 58U ²⁾																																						
		20	09 18 520 □ 803 58U ²⁾																																						
		26	09 18 526 □ 803 58U ²⁾																																						
30		09 18 530 □ 803 58U ²⁾																																							
40		09 18 540 □ 803 58U ³⁾																																							
with strain relief clamp 	6	09 18 506 □ 813	09 18 506 □ 814*		<table border="1"> <tr> <th>No. of contacts</th> <th>6</th> <th>10</th> <th>14</th> <th>16</th> <th>20</th> </tr> <tr> <td>A</td> <td>12.20</td> <td>17.30</td> <td>22.40</td> <td>24.90</td> <td>30.00</td> </tr> <tr> <td>B</td> <td>5.08</td> <td>10.16</td> <td>15.24</td> <td>17.78</td> <td>22.86</td> </tr> </table>	No. of contacts	6	10	14	16	20	A	12.20	17.30	22.40	24.90	30.00	B	5.08	10.16	15.24	17.78	22.86																		
	No. of contacts	6	10			14	16	20																																	
	A	12.20	17.30			22.40	24.90	30.00																																	
	B	5.08	10.16			15.24	17.78	22.86																																	
	10	09 18 510 □ 813	09 18 510 □ 814*																																						
	14	09 18 514 □ 813	09 18 514 □ 814*																																						
	16	09 18 516 □ 813	09 18 516 □ 814*																																						
	20	09 18 520 □ 813	09 18 520 □ 814*																																						
	24	09 18 524 □ 813																																							
	26	09 18 526 □ 813	09 18 526 □ 814*																																						
	30	09 18 530 □ 813	09 18 530 □ 814*																																						
	34	09 18 534 □ 813	09 18 534 □ 814*																																						
	40	09 18 540 □ 813	09 18 540 □ 814*																																						
	50	09 18 550 □ 813	09 18 550 □ 814*																																						
	60	09 18 560 □ 813	09 18 560 □ 814*																																						
	64	09 18 564 □ 813	09 18 564 □ 814*																																						
with strain relief clamp with bulk packaging 3) Packaging unit (PU) 3,000 pieces 4) PU 2,500 pieces 5) PU 2,000 pieces 6) PU 1,500 pieces 7) PU 1,000 pieces	6	09 18 506 □ 813 58U ³⁾		<table border="1"> <tr> <th>No. of contacts</th> <th>24</th> <th>26</th> <th>30</th> <th>34</th> <th>40</th> </tr> <tr> <td>A</td> <td>35.18</td> <td>37.60</td> <td>42.70</td> <td>47.80</td> <td>55.40</td> </tr> <tr> <td>B</td> <td>27.94</td> <td>30.48</td> <td>35.56</td> <td>40.64</td> <td>48.26</td> </tr> </table>	No. of contacts	24	26	30	34	40	A	35.18	37.60	42.70	47.80	55.40	B	27.94	30.48	35.56	40.64	48.26	<table border="1"> <tr> <th>No. of contacts</th> <th>50</th> <th>60</th> <th>64</th> <th></th> <th></th> </tr> <tr> <td>A</td> <td>68.10</td> <td>80.80</td> <td>85.90</td> <td></td> <td></td> </tr> <tr> <td>B</td> <td>60.96</td> <td>73.66</td> <td>78.74</td> <td></td> <td></td> </tr> </table>	No. of contacts	50	60	64			A	68.10	80.80	85.90			B	60.96	73.66	78.74		
	No. of contacts	24	26		30	34	40																																		
	A	35.18	37.60		42.70	47.80	55.40																																		
	B	27.94	30.48		35.56	40.64	48.26																																		
	No. of contacts	50	60		64																																				
	A	68.10	80.80		85.90																																				
	B	60.96	73.66		78.74																																				
	10	09 18 510 □ 813 58U ³⁾																																							
14	09 18 514 □ 813 58U ⁴⁾																																								
16	09 18 516 □ 813 58U ⁴⁾																																								
20	09 18 520 □ 813 58U ⁵⁾																																								
26	09 18 526 □ 813 58U ⁶⁾																																								
30	09 18 530 □ 813 58U ⁵⁾																																								
34	09 18 534 □ 813 58U ⁷⁾																																								
40	09 18 540 □ 813 58U ⁷⁾																																								

SEK

For performance level 3 please specify digit 7
 For performance level 2 please specify digit 6
 S4 = 0.76 μm (30 μinch) Au or PdNi equivalent



¹⁾ Pitch tolerance: ± 0.1
 * Not normally kept in stock

Number of contacts

6-64



Strain relief clamp/Locking lever

Identification	No. of contacts	Part number	Drawing	Dimensions in mm																												
Strain relief clamp	6	09 18 506 9002	<table border="1"> <thead> <tr> <th>No. of contacts</th> <th>A</th> </tr> </thead> <tbody> <tr><td>6</td><td>12.2</td></tr> <tr><td>10</td><td>17.3</td></tr> <tr><td>14</td><td>22.4</td></tr> <tr><td>16</td><td>24.9</td></tr> <tr><td>20</td><td>30.0</td></tr> <tr><td>24</td><td>35.18</td></tr> <tr><td>26</td><td>37.6</td></tr> <tr><td>30</td><td>42.7</td></tr> <tr><td>34</td><td>47.8</td></tr> <tr><td>40</td><td>55.4</td></tr> <tr><td>50</td><td>68.1</td></tr> <tr><td>60</td><td>80.8</td></tr> <tr><td>64</td><td>85.9</td></tr> </tbody> </table>	No. of contacts	A	6	12.2	10	17.3	14	22.4	16	24.9	20	30.0	24	35.18	26	37.6	30	42.7	34	47.8	40	55.4	50	68.1	60	80.8	64	85.9	
	No. of contacts	A																														
	6	12.2																														
	10	17.3																														
	14	22.4																														
	16	24.9																														
	20	30.0																														
	24	35.18																														
	26	37.6																														
	30	42.7																														
	34	47.8																														
	40	55.4																														
	50	68.1																														
	60	80.8																														
	64	85.9																														
	10	09 18 510 9002																														
	14	09 18 514 9002																														
	16	09 18 516 9002																														
	20	09 18 520 9002																														
	24	09 18 524 9002																														
26	09 18 526 9002																															
30	09 18 530 9002																															
34	09 18 534 9002																															
40	09 18 540 9002																															
50	09 18 550 9002																															
60	09 18 560 9002																															
64	09 18 564 9002																															
with bulk packaging	6	09 18 506 9002 58U ³⁾	6	12.2																												
	10	09 18 510 9002 58U ³⁾	10	17.3																												
	14	09 18 514 9002 58U ³⁾	14	22.4																												
	16	09 18 516 9002 58U ³⁾	16	24.9																												
	20	09 18 520 9002 58U ³⁾	20	30.0																												
	26	09 18 526 9002 58U ³⁾	26	37.6																												
	30	09 18 530 9002 58U ³⁾	30	42.7																												
	34	09 18 534 9002 58U ⁴⁾	34	47.8																												
	40	09 18 540 9002 58U ⁴⁾	40	55.4																												
<p>³⁾ Packaging unit 5,000 pieces</p> <p>⁴⁾ Packaging unit 3,000 pieces</p>																																
Locking lever for female connector Only in conjunction with low-profile male header and strain relief ⁵⁾ Packaging unit 100 pieces ⁶⁾ Packaging unit 5,000 pieces		09 18 000 9905 ¹⁾⁵⁾ 09 18 000 9905 58U ¹⁾⁶⁾		<p>When the security of latching is required and space is a premium, these locking levers can be fitted onto the strain relief of the HARTING female connector. This can then be used in conjunction with male low-profile headers (see pages 08.14 and 08.15).</p>																												
Coding system with loss of contact Code pin Removal tool for male contacts		09 18 000 9901 ²⁾ 09 99 000 0133		<p>To avoid cross-plugging adjacent connectors a coding system is required. A code pin is inserted into the appropriate cavity in the female connector. The corresponding male contact is removed by a special removal tool.</p>																												

SEK

1) Order 2 per female connector
 2) Part number comprises 6 code pins

Number of contacts 4, 6, 8, 10, 14, 16, 20, 24, 26, 30, 34, 40, 50, 60, 64

Approvals



UL recognized: E102079

Pitch

On pcb side: 2.54 mm [0.100"]
On cable side: 1.27 mm [0.050"]

Rated current

2.6 A min. at ambient temperature of 30 °C

Working voltage

320 V
for pollution degree 1

Test voltage $U_{r.m.s.}$

1 kV AC – 1 minute

Contact resistance
Insulation resistance

35 mΩ max. mated
 $\geq 10^9 \Omega$

Temperature range

-55 °C ... +105 °C
The maximum temperature includes heating of contacts and ambient temperature

Terminations

Solder pins:
0.5 mm x 0.35 mm
Dimensions for pcb hole:
Standard version: $\varnothing 0.8^{\pm 0.1}$ mm
Kinked version: $\varnothing 0.85^{\pm 0.15}$ mm
Diagonal: 0.63 mm

IDC flat cable
1.27 mm [0.050"] pitch: AWG 28/7

Materials

Moulding Thermoplastic resin (PBT)
UL 94-V0

Contact Copper alloy

Current carrying capacity

The current carrying capacity is limited by maximum temperature of materials for inserts and contacts including terminals. The current capacity-curve is valid for continuous, not interrupted current-loaded contacts of connectors when simultaneous power on all contacts is given, without exceeding the maximum temperature. Control and test procedures according to IEC 60 512.

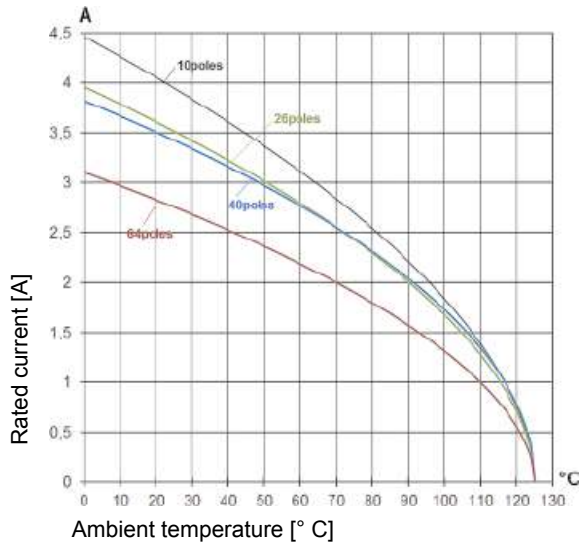

Derating curve at $I_{max.} \times 0.8$ (IEC 60512-2)

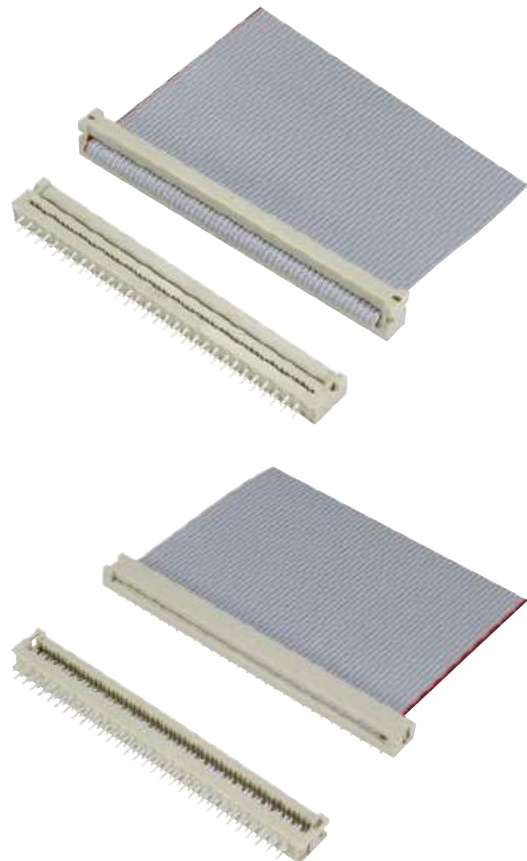

Number of contacts

4-64



Pcb transition connector,
2 rows with strain relief clamp, low-profile with 5.5 mm height

Identification	No. of contacts	Part number	Drawing	Dimensions in mm
----------------	-----------------	-------------	---------	------------------

Pcb transition connector 2 rows with strain relief clamp Standard low-profile version	No. of contacts	Part number
	4	09 18 104 9623*
6	09 18 106 9623*	
8	09 18 108 9623*	
10	09 18 110 9623*	
14	09 18 114 9623*	
16	09 18 116 9623*	
20	09 18 120 9623*	
24	09 18 124 9623*	
26	09 18 126 9623*	
30	09 18 130 9623*	
34	09 18 134 9623*	
40	09 18 140 9623	
50	09 18 150 9623*	
60	09 18 160 9623	
64	09 18 164 9623*	

No. of contacts	A±0.38	B±0.10
4	10.38	2.54 x 1 = 2.54
6	12.92	2.54 x 2 = 5.08
8	15.46	2.54 x 3 = 7.62
10	18.00	2.54 x 4 = 10.16
14	23.08	2.54 x 6 = 15.24
16	25.62	2.54 x 7 = 17.78
20	30.74	2.54 x 9 = 22.86
24	35.78	2.54 x 11 = 27.94
26	38.32	2.54 x 12 = 30.48
30	43.40	2.54 x 14 = 35.56
34	48.48	2.54 x 16 = 40.64
40	56.10	2.54 x 19 = 48.26
50	68.80	2.54 x 24 = 60.96
60	81.50	2.54 x 29 = 73.66
64	86.58	2.54 x 31 = 78.74

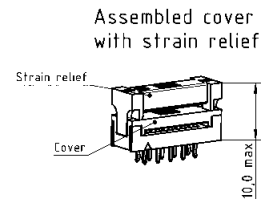

Pcb transition connector 2 rows with strain relief clamp Kinked low-profile version 2 kinked pins at each extremity	No. of contacts	Part number
	4	09 18 104 9423*
6	09 18 106 9423*	
8	09 18 108 9423*	
10	09 18 110 9423*	
14	09 18 114 9423*	
16	09 18 116 9423*	
20	09 18 120 9423*	
24	09 18 124 9423*	
26	09 18 126 9423*	
30	09 18 130 9423*	
34	09 18 134 9423*	
40	09 18 140 9423	
50	09 18 150 9423*	
60	09 18 160 9423	
64	09 18 164 9423*	

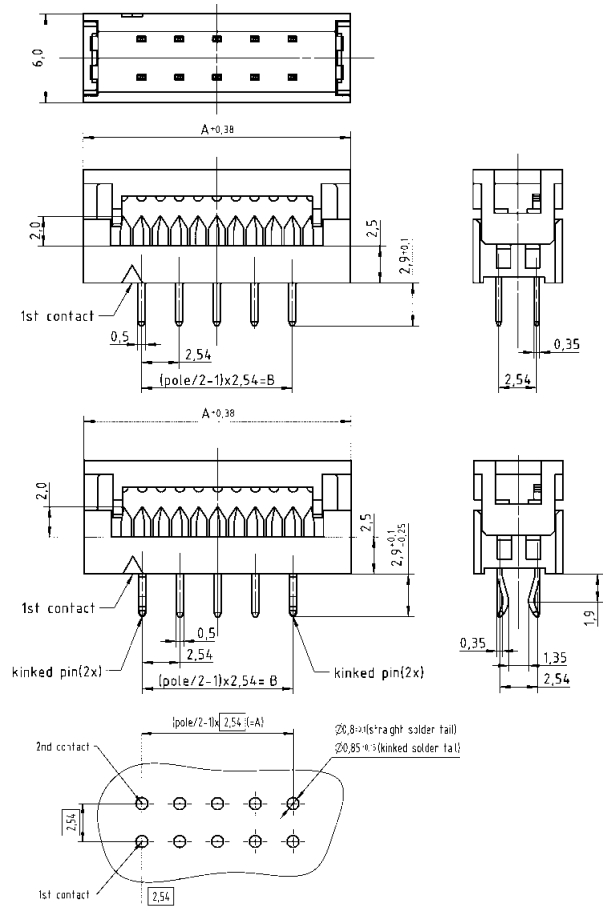

Board drillings

Not released for halogen free flat cables
* Available on request

SEK

Number of contacts

4-64



Pcb transition connector,
2 rows without strain relief clamp, low-profile with 5.5 mm height

Identification	No. of contacts	Part number	Drawing	Dimensions in mm
----------------	-----------------	-------------	---------	------------------

Pcb transition connector
2 rows without strain relief clamp
Standard low-profile version

4	09 18 104 9622
6	09 18 106 9622
8	09 18 108 9622
10	09 18 110 9622
14	09 18 114 9622
16	09 18 116 9622
20	09 18 120 9622
24	09 18 124 9622
26	09 18 126 9622
30	09 18 130 9622
34	09 18 134 9622
40	09 18 140 9622
50	09 18 150 9622
60	09 18 160 9622
64	09 18 164 9622

No. of contacts	A±0.38	B±0.10
4	10.38	2.54 x 1 = 2.54
6	12.92	2.54 x 2 = 5.08
8	15.46	2.54 x 3 = 7.62
10	18.00	2.54 x 4 = 10.16
14	23.08	2.54 x 6 = 15.24
16	25.62	2.54 x 7 = 17.78
20	30.74	2.54 x 9 = 22.86
24	35.78	2.54 x 11 = 27.94
26	38.32	2.54 x 12 = 30.48
30	43.40	2.54 x 14 = 35.56
34	48.48	2.54 x 16 = 40.64
40	56.10	2.54 x 19 = 48.26
50	68.80	2.54 x 24 = 60.96
60	81.50	2.54 x 29 = 73.66
64	86.58	2.54 x 31 = 78.74

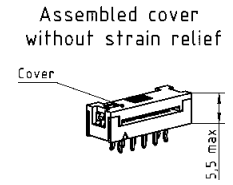

Pcb transition connector
2 rows without strain relief clamp
Kinked low-profile version
2 kinked pins at each extremity

4	09 18 104 9422
6	09 18 106 9422
8	09 18 108 9422
10	09 18 110 9422
14	09 18 114 9422
16	09 18 116 9422
20	09 18 120 9422
24	09 18 124 9422
26	09 18 126 9422
30	09 18 130 9422
34	09 18 134 9422
40	09 18 140 9422
50	09 18 150 9422
60	09 18 160 9422
64	09 18 164 9422

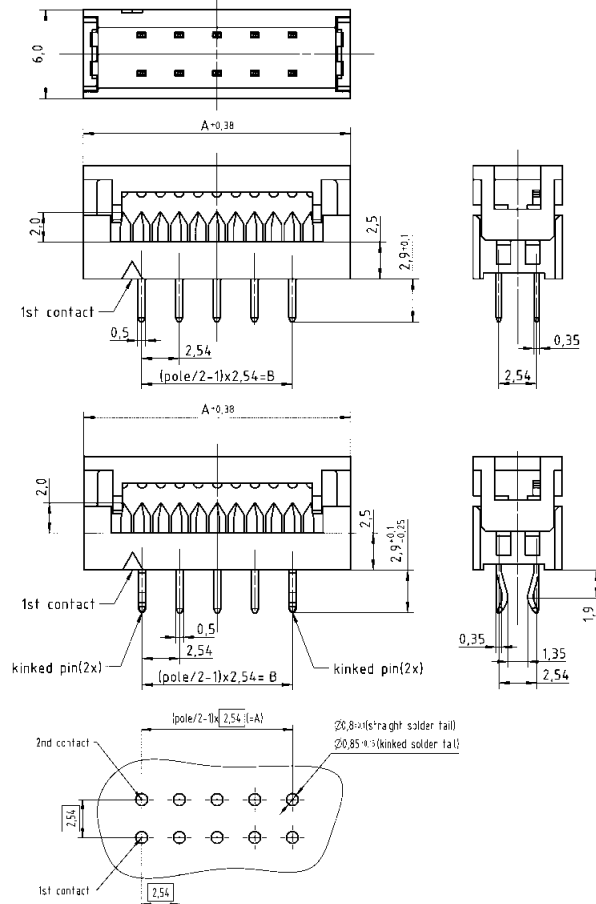

Board drillings

Number of contacts

4-64



Strain relief clamp

Identification	No. of contacts	Part number	Drawing	Dimensions in mm
----------------	-----------------	-------------	---------	------------------

Strain relief clamp

4	98 18 104 9002*
6	98 18 106 9002*
8	98 18 108 9002*
10	98 18 110 9002*
14	98 18 114 9002*
16	98 18 116 9002*
20	98 18 120 9002*
24	98 18 124 9002*
26	98 18 126 9002*
30	98 18 130 9002*
34	98 18 134 9002*
40	98 18 140 9002
50	98 18 150 9002*
60	98 18 160 9002
64	98 18 164 9002*

No. of contacts	A	B	C
4	10.38	8.58	5.98
6	12.92	11.12	8.52
8	15.46	13.66	11.06
10	18.00	16.20	13.60
14	23.08	21.28	18.68
16	25.62	23.82	21.22
20	30.70	28.90	26.30
24	35.78	33.98	31.38
26	38.32	36.52	33.92
30	43.40	41.60	39.00
34	48.48	46.68	44.08
40	56.10	54.30	51.70
50	68.80	67.00	64.40
60	81.50	79.70	77.10
64	86.58	84.78	82.18

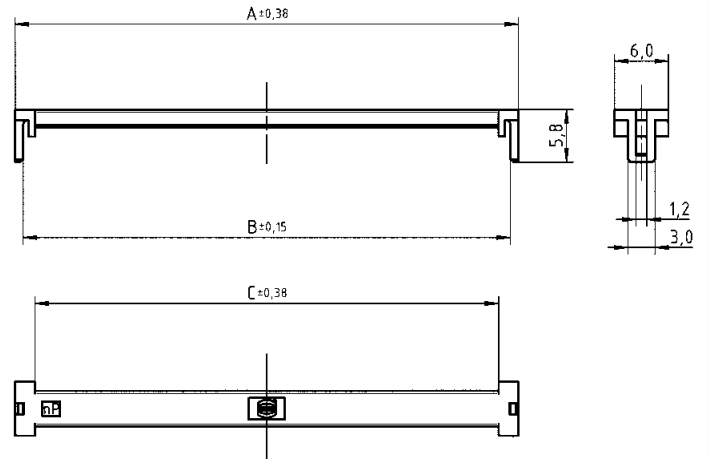

* Available on request

Number of contacts* 10, 16, 20, 26, 34, 40, 50

Pitch
On pcb side: 2.54 mm [0.100"]
On cable side: 1.27 mm [0.050"]

Working current 1 A

Test voltage $U_{r.m.s.}$ 500 V

Contact resistance $\leq 20 \text{ m}\Omega$
Insulation resistance $\geq 10^{12} \Omega$

Temperature range -40 °C ... +125 °C
The maximum temperature includes heating of contacts and ambient temperature

Terminations
Solder pins
0.45 mm x 0.35 mm
for pcb hole \varnothing 0.8 mm
Diagonal: 0.58 mm
IDC flat cable
1.27 mm [0.050"] pitch:
AWG 28/7

Materials
Moulding Thermoplastic resin (PC)
UL 94-V0

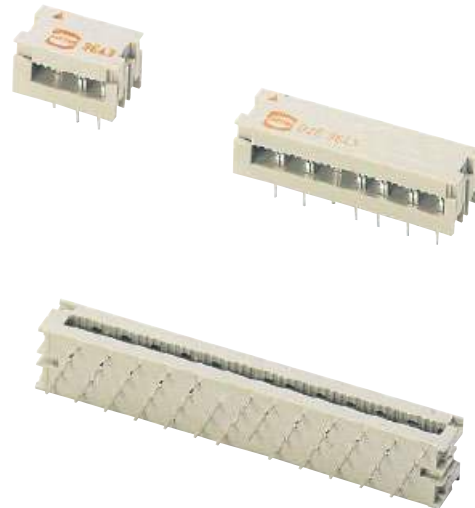

Number of contacts

10-50



Pcb transition connector, 4 rows

Identification	No. of contacts	Part number	Drawing	Dimensions in mm
----------------	-----------------	-------------	---------	------------------

Pcb transition connector²⁾
4 rows

No. of contacts	A	B
10	17.78	1.27 x 9 = 11.43
16	25.40	1.27 x 15 = 19.05
20	30.48	1.27 x 19 = 24.13
26	38.10	1.27 x 25 = 31.75
34	48.26	1.27 x 33 = 41.91
40	55.88	1.27 x 39 = 49.53
50	68.58	1.27 x 49 = 62.23

No. of contacts	A	B
10	17.78	1.27 x 9 = 11.43
16	25.40	1.27 x 15 = 19.05
20	30.48	1.27 x 19 = 24.13
26	38.10	1.27 x 25 = 31.75
34	48.26	1.27 x 33 = 41.91
40	55.88	1.27 x 39 = 49.53
50	68.58	1.27 x 49 = 62.23

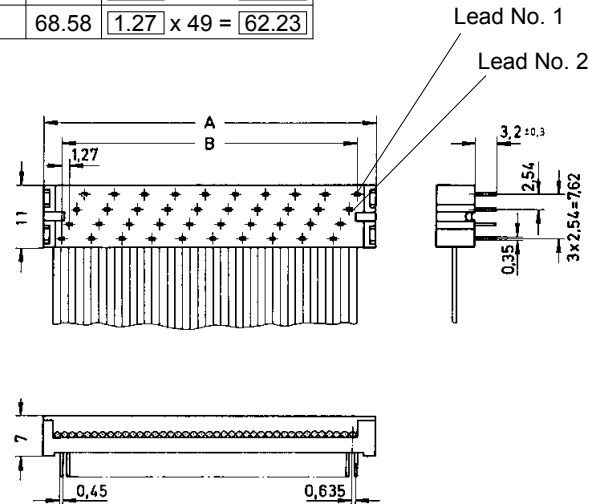

Board drillings

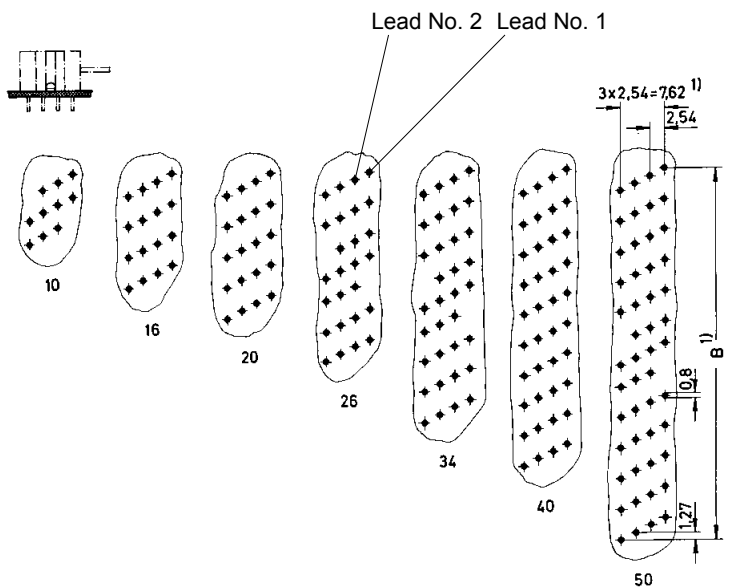

* Not normally kept in stock.

¹⁾ Pitch tolerance: ± 0.1

²⁾ Not released for halogen free flat cables

Number of contacts*	14, 16, 24, 28, 40
Pitch	On pcb side: 2.54 mm [0.100"] On cable side: 1.27 mm [0.050"]
Working current	1 A
Test voltage $U_{r.m.s.}$	500 V
Contact resistance Insulation resistance	$\leq 20 \text{ m}\Omega$ $\geq 10^{12} \Omega$
Temperature range	-40 °C ... +125 °C The maximum temperature includes heating of contacts and ambient temperature
Terminations	Solder pins 0.45 mm x 0.35 mm for pcb hole \varnothing 0.8 mm Diagonal: 0.58 mm IDC flat cable 1.27 mm [0.050"] pitch: AWG 28/7
Materials Moulding	Thermoplastic resin (PC) UL 94-V0

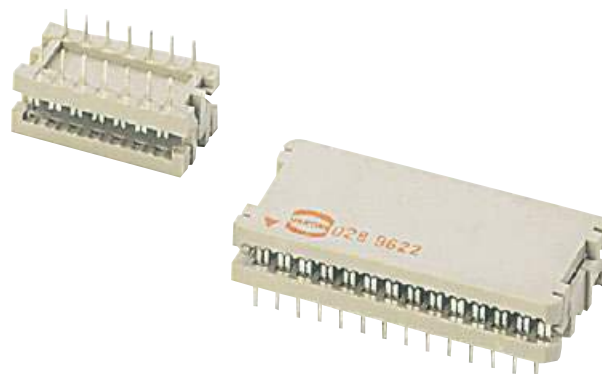

Number of contacts

14-40



DIP connector for IC base or for soldering into pcb

Identification No. of contacts Part number Drawing Dimensions in mm

Identification	No. of contacts	Part number
DIP connector ²⁾		
	14	09 17 014 9622*
	16	09 17 016 9622*
	24	09 17 024 9622*
	28	09 17 028 9622*
	40	09 17 040 9622*

No. of contacts	A	B	C	D
14	20.5	2.54 x 6 = 15.24	11	7.62
16	23.0	2.54 x 7 = 17.78	11	7.62
24	33.0	2.54 x 11 = 27.94	18.7	15.24
28	38.1	2.54 x 13 = 33.02	18.7	15.24
40	53.3	2.54 x 19 = 48.26	18.7	15.24

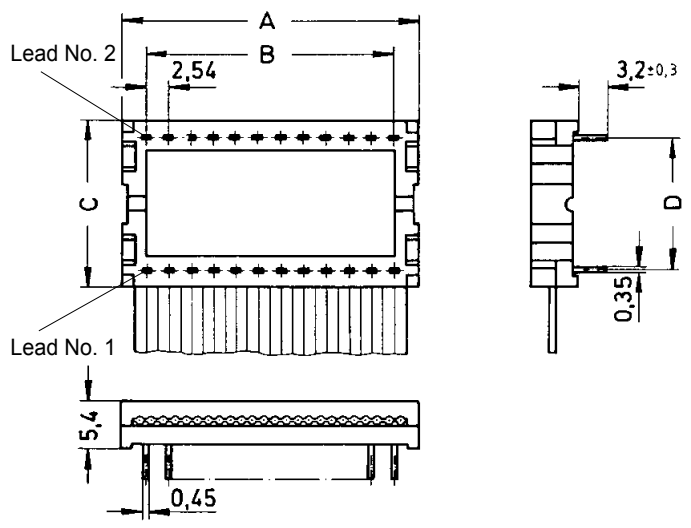

Board drillings

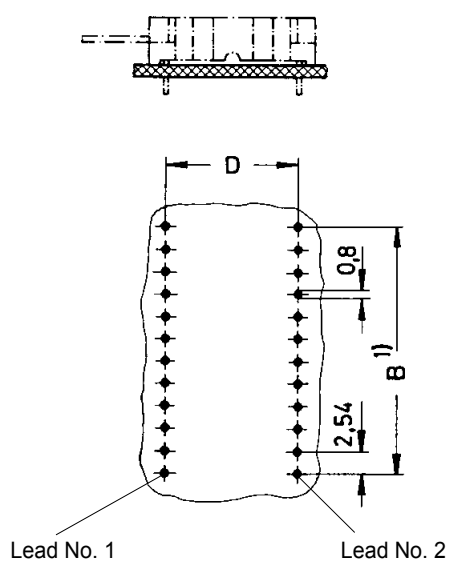

* Not normally kept in stock
 1) Pitch tolerance: ± 0.1
 2) Not released for halogen free flat cables

Number of contacts	64
Pitch	2.54 mm [0.100"]
Working current	1 A max.
Clearance Creepage	≥ 1.2 mm ≥ 1.2 mm
Working voltage	according to the safety regulations of the equipment
Test voltage $U_{r.m.s.}$	1 kV
Contact resistance Insulation resistance	≤ 20 mΩ ≥ 10 ¹² Ω
Temperature range	-55 °C ... +125 °C The maximum temperature includes heating of contacts and ambient temperature
Termination Female connector	Insulation displacement: AWG 28/7
Insertion and withdrawal force	≤ 60 N
Materials Moulding Contacts Contact surface Contact zone	Thermoplastic resin, glass-fibre filled, UL 94-V0 Copper alloy selectively plated according to performance level



Number of contacts

64

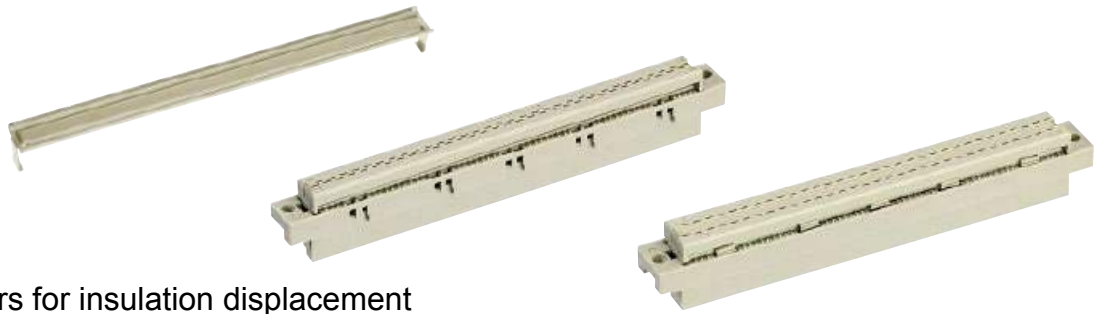

Female connectors for insulation displacement

Identification	No. of contacts	Part number	Drawing	Dimensions in mm
----------------	-----------------	-------------	---------	------------------

Female connector for insulation displacement Type B	64	performance level 2 09 02 264 6828	<p>Lead number 1 of flat cable on contact 1 b</p> <p>Contact arrangement View from termination side</p>	
		performance level 3 09 02 264 7828		

Type C	64	performance level 2 09 03 264 6828 09 03 764 6828 ^{c)}	<p>Lead number 1 of flat cable on contact 1 c</p> <p>Contact arrangement View from termination side</p>	
		performance level 3 09 03 264 7828		

Strain relief for types B and C	09 03 000 9940	<p>Mateable with 3-row male connector Type C. No female contact in middle row.</p> <p>Panel cut out</p>							
		<table border="1"> <thead> <tr> <th></th> <th>a</th> <th>b</th> </tr> </thead> <tbody> <tr> <td>Type B</td> <td>8.3</td> <td>10.16</td> </tr> <tr> <td>Type C</td> <td>10.8</td> <td>12.7</td> </tr> </tbody> </table>		a	b	Type B	8.3	10.16	Type C
	a	b							
Type B	8.3	10.16							
Type C	10.8	12.7							

Male connectors see DIN 41612 catalogue
^{c)} Connectors with coding

SEK

Number of contacts 6, 10, 14, 16, 20, 26, 34, 40, 50, 60, 64

Contact arrangement straight

Contact length 5.5 mm

Approvals IEC 60603-13
DIN EN 60603-13
D 2632
BT 224
NFC 93-428 (HE 10)
UL recognized: E102079



Pitch 2.54 mm [0.100"]

Working current 1 A

Test voltage $U_{r.m.s.}$ 1 kV

Contact resistance $\leq 20 \text{ m}\Omega$
Insulation resistance $\geq 10^9 \Omega$

Temperature range -55 °C ... +105 °C
The maximum temperature includes heating of contacts and ambient temperature

Press-in
Diameter of pcb plated through holes $\varnothing 1.0^{+0.09}_{-0.06} \text{ mm}$
Recommended pcb holes for press-in process
Hole: $\varnothing 1.12 - 1.15 \text{ mm}$
Cu : 25 – 75 μm
Sn : 5 – 15 μm
Pcb thickness 1.6 – 3.2 mm

Materials Moulding Thermoplastic resin (PBT)
UL 94-V0

Contact surface Contact zone plated according to performance level¹⁾

Insertion and withdrawal forces

Number of contacts	Maximum force [N]	
	Performance level 1 and 2	Performance level 3
6	12	18
10	20	30
14	28	42
16	32	48
20	40	60
26	52	78
34	68	102
40	80	120
50	100	150
60	120	180
64	128	192

¹⁾ Performance level 3 as per IEC 60603-13, ≥ 50 mating cycles, no gas test
Performance level 2 as per IEC 60603-13, ≥ 250 mating cycles, 4 days gas test
S4, plating = 0.76 μm (30 μinch) Au or PdNi equivalent

Number of contacts

6-64

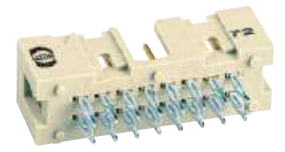

Low-profile male header, straight press-in pins

Identification	No. of contacts	Part number	Drawing	Dimensions in mm
----------------	-----------------	-------------	---------	------------------

Low-profile male header with straight press-in terminations
Length: 5.5 mm

6	09 18 506	□ 329
10	09 18 510	□ 329
14	09 18 514	□ 329
16	09 18 516	□ 329
20	09 18 520	□ 329
26	09 18 526	□ 329
34	09 18 534	□ 329
40	09 18 540	□ 329
50	09 18 550	□ 329
60	09 18 560	□ 329
64	09 18 564	□ 329

No. of contacts	A	B	E
6	15.2	12.78	2.54 x 2 = 5.08
10	20.3	17.86	2.54 x 4 = 10.16
14	25.4	22.94	2.54 x 6 = 15.24
16	27.9	25.48	2.54 x 7 = 17.78
20	33.0	30.56	2.54 x 9 = 22.86
26	40.6	38.18	2.54 x 12 = 30.48
34	50.8	48.34	2.54 x 16 = 40.64
40	58.4	55.96	2.54 x 19 = 48.26
50	71.3	68.66	2.54 x 24 = 60.96
60	84.0	81.36	2.54 x 29 = 73.66
64	89.1	86.44	2.54 x 31 = 78.74

Marking No. 1 contact

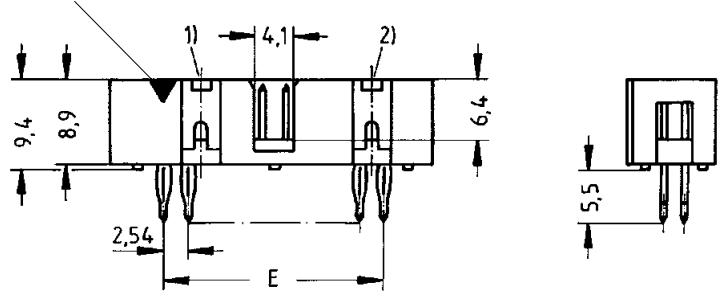

No. 2 contact

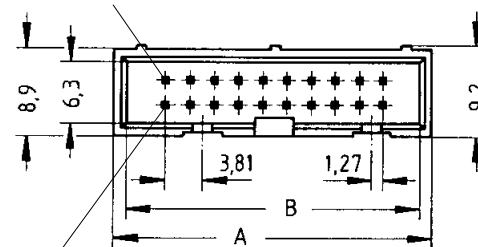

No. 1 contact

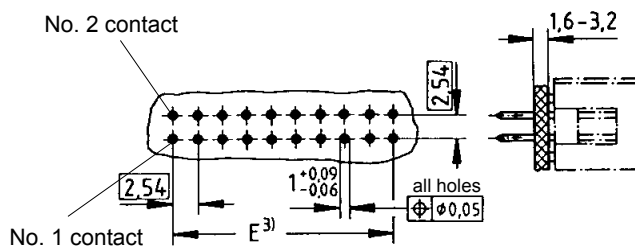

Board drillings

For Performance Level 3 please specify digit 7
For Performance Level 2 please specify digit 6
S4 = 0.76 μm (30 μinch) Au or PdNi equivalent



Not normally kept in stock

- 1) No polarization slot for 6, 10 or 14 way
- 2) No polarization slot for 6 way
- 3) Pitch tolerance: ± 0.1

Number of contacts 6, 10, 14, 16, 20, 24, 26, 30, 34, 40, 50, 60, 64

Contact arrangement straight, angled

Contact length 2.9 mm

Approvals IEC 60603-13
DIN EN 60603-13
D 2632
BT 224
NFC 93-428 (HE 10)

Pitch 2.54 mm [0.100"]

Working current 1 A

Working voltage 500 V
for pollution degree 1

Test voltage $U_{r.m.s.}$ 1 kV

Contact resistance $\leq 20 \text{ m}\Omega$
Insulation resistance $\geq 10^9 \Omega$

Temperature range -55 °C ... +125 °C
during reflow soldering max. + 240 °C for 60 s
The higher temperature limit includes the local ambient and heating effect of the contacts under load

Terminations For pcb hole $\varnothing 1 \pm 0.1 \text{ mm}$
DIN IEC 52 141
Diagonal: 0.79 mm

Materials Moulding Thermoplastic resin (PCT)
UL 94-V0

Contact surface Contact zone gold-plated according to performance level¹⁾

Options on request

Colour of connectors black

For pick & place process Tape & Reel packaging
with/without vacuum plate
Tube packaging
with/without vacuum plate



Insertion and withdrawal forces

Number of contacts	Maximum force [N]	
	Performance level 1 and 2	Performance level 3
6	12	18
10	20	30
14	28	42
16	32	48
20	40	60
24	48	72
26	52	78
30	60	90
34	68	102
40	80	120
50	100	150
60	120	180
64	128	192



¹⁾ Performance level 3 as per IEC 60603-13, ≥ 50 mating cycles, no gas test
Performance level 2 as per IEC 60603-13, ≥ 250 mating cycles, 4 days gas test
S4, plating = 0.76 μm (30 μinch) Au or PdNi equivalent

Number of contacts

6-64

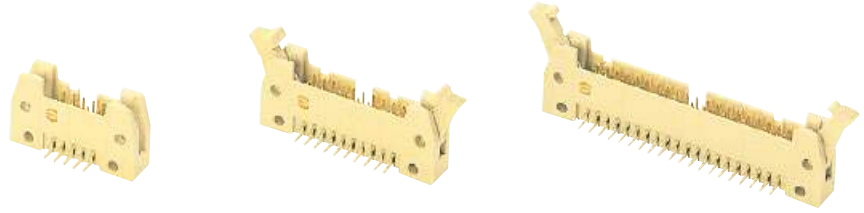

SMC male header with angled solder pins

Identification	No. of contacts	Part number		
		Without levers	With short levers	With long levers
SMC male header with angled solder pins Length: 2.9 mm				
	6	09 19 506 □ 923	09 19 506 □ 913	09 19 506 □ 903
	10	09 19 510 □ 923	09 19 510 □ 913	09 19 510 □ 903
	14	09 19 514 □ 923	09 19 514 □ 913	09 19 514 □ 903
	16	09 19 516 □ 923	09 19 516 □ 913	09 19 516 □ 903
	20	09 19 520 □ 923	09 19 520 □ 913	09 19 520 □ 903
	24	09 19 524 □ 923	09 19 524 □ 913	09 19 524 □ 903
	26	09 19 526 □ 923	09 19 526 □ 913	09 19 526 □ 903
	30	09 19 530 □ 923	09 19 530 □ 913	09 19 530 □ 903
	34	09 19 534 □ 923	09 19 534 □ 913	09 19 534 □ 903
	40	09 19 540 □ 923	09 19 540 □ 913	09 19 540 □ 903
	50	09 19 550 □ 923	09 19 550 □ 913	09 19 550 □ 903
	60	09 19 560 □ 923	09 19 560 □ 913	09 19 560 □ 903
	64	09 19 564 □ 923	09 19 564 □ 913	09 19 564 □ 903

SEK

Kinked version on request

* Not normally kept in stock
For accessories see page 08.48
For dimensions see page 08.39

For performance level 3 please specify digit 7*
For performance level 2 please specify digit 6*
S4 = 0.76 µm (30 µinch) Au or PdNi equivalent 5*



Number of contacts

6-64

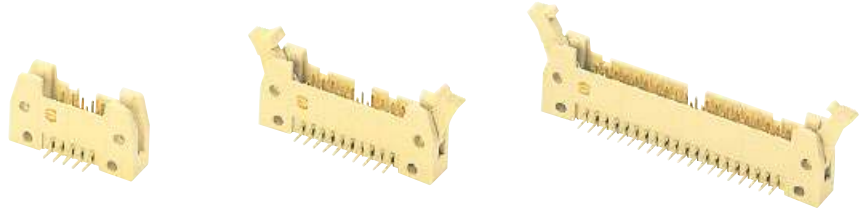

SMC male header with angled solder pins

Identification

Drawing

Dimensions in mm

SMC male header

No. of contacts	A	B	D	E	F	G
6	26.9	16.76	12.45	2.54 x 2 = 5.08	36.9	40.3
10	32.0	21.84	17.53	2.54 x 4 = 10.16	42.0	45.4
14	37.1	26.92	22.61	2.54 x 6 = 15.24	47.1	50.4
16	39.6	29.46	25.15	2.54 x 7 = 17.78	49.6	53.0
20	44.7	34.54	30.23	2.54 x 9 = 22.86	54.7	58.1
24	49.8	39.62	35.91	2.54 x 11 = 27.94	59.8	63.2
26	52.3	42.16	37.85	2.54 x 12 = 30.48	62.3	65.7
30	57.7	47.24	43.83	2.54 x 14 = 35.56	68.2	68.6
34	62.5	52.32	48.01	2.54 x 16 = 40.64	72.5	75.8
40	70.1	59.94	55.63	2.54 x 19 = 48.26	80.1	83.5
50	82.8	72.64	68.33	2.54 x 24 = 60.96	92.8	96.2
60	95.5	85.34	81.03	2.54 x 29 = 73.66	105.5	108.9
64	100.6	90.42	86.11	2.54 x 31 = 78.74	110.6	113.9

Short levers

for use with female connector without strain relief clamp

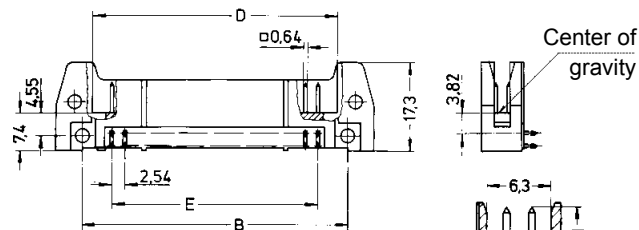

Long levers

for use with female connector with strain relief clamp

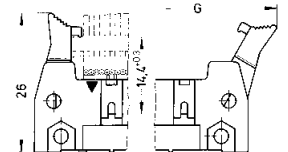
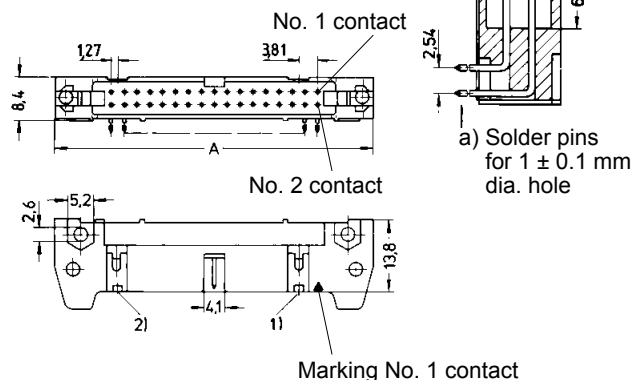

Board drillings

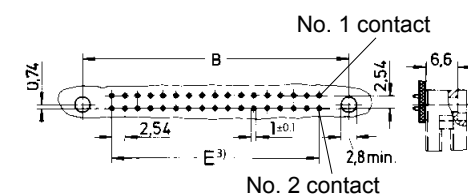

1) No polarization slot for 6, 10 or 14 way male header

2) No polarization slot for 6 way male header

3) Pitch tolerance: ± 0.1

Number of contacts

6-64

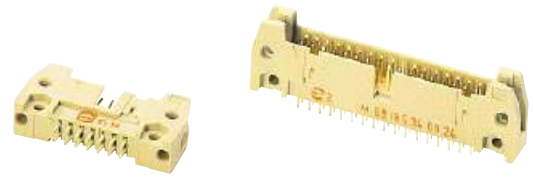

SMC male header with straight solder pins

Identification	No. of contacts	Part number		
		Without levers	With short levers	With long levers
SMC male header with straight solder pins Length: 2.9 mm	6	09 19 506 □ 924	09 19 506 □ 914	09 19 506 □ 904
	10	09 19 510 □ 924	09 19 510 □ 914	09 19 510 □ 904
	14	09 19 514 □ 924	09 19 514 □ 914	09 19 514 □ 904
	16	09 19 516 □ 924	09 19 516 □ 914	09 19 516 □ 904
	20	09 19 520 □ 924	09 19 520 □ 914	09 19 520 □ 904
	24	09 19 524 □ 924	09 19 524 □ 914	09 19 524 □ 904
	26	09 19 526 □ 924	09 19 526 □ 914	09 19 526 □ 904
	30	09 19 530 □ 924	09 19 530 □ 914	09 19 530 □ 904
	34	09 19 534 □ 924	09 19 534 □ 914	09 19 534 □ 904
	40	09 19 540 □ 924	09 19 540 □ 914	09 19 540 □ 904
	50	09 19 550 □ 924	09 19 550 □ 914	09 19 550 □ 904
	60	09 19 560 □ 924	09 19 560 □ 914	09 19 560 □ 904
	64	09 19 564 □ 924	09 19 564 □ 914	09 19 564 □ 904

SEK

* Not normally kept in stock
For accessories see page 08.48
For dimensions see page 08.41

For performance level 3 please specify digit 7*
For performance level 2 please specify digit 6*
S4 = 0.76 µm (30 µinch) Au or PdNi equivalent



Number of contacts

6-64

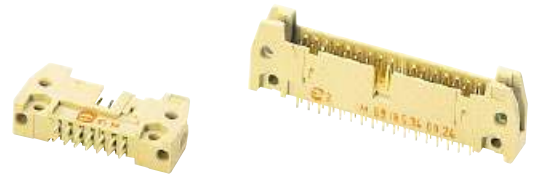

SMC male header with straight solder pins

Identification

Drawing

Dimensions in mm

SMC male header

No. of contacts	A	C	D	E	F	G
6	26.9	22.86	12.45	2.54 x 2 = 5.08	36.9	40.3
10	32.0	27.94	17.53	2.54 x 4 = 10.16	42.0	45.4
14	37.1	33.02	22.61	2.54 x 6 = 15.24	47.1	50.4
16	39.6	35.56	25.15	2.54 x 7 = 17.78	49.6	53.0
20	44.7	40.64	30.23	2.54 x 9 = 22.86	54.7	58.1
24	49.8	45.72	35.91	2.54 x 11 = 27.94	59.8	63.2
26	52.3	48.26	37.85	2.54 x 12 = 30.48	62.3	65.7
30	57.7	53.34	43.83	2.54 x 14 = 35.56	68.2	68.6
34	62.5	58.42	48.01	2.54 x 16 = 40.64	72.5	75.8
40	70.1	66.04	55.63	2.54 x 19 = 48.26	80.1	83.5
50	82.8	78.74	68.33	2.54 x 24 = 60.96	92.8	96.2
60	95.5	91.44	81.03	2.54 x 29 = 73.66	105.5	108.9
64	100.6	96.52	86.11	2.54 x 31 = 78.74	110.6	113.9

Short levers

for use with female connector without strain relief clamp

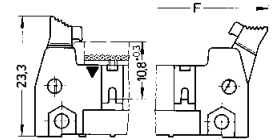
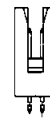
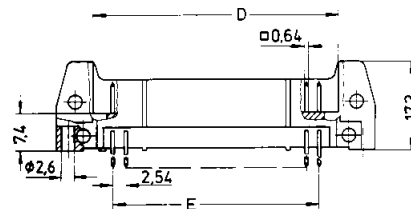

Long levers

for use with female connector with strain relief clamp

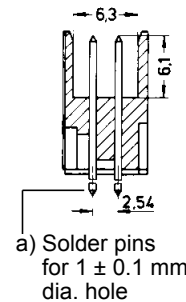
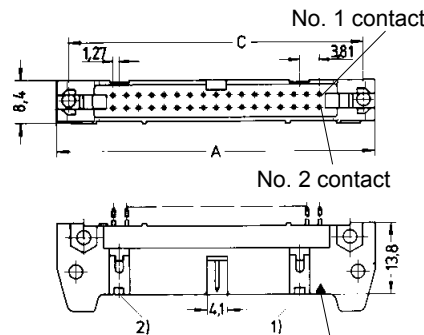

a) Solder pins for 1 ± 0.1 mm dia. hole

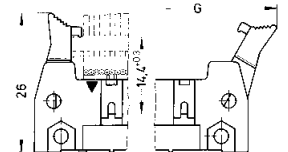

Marking No. 1 contact

Board drillings

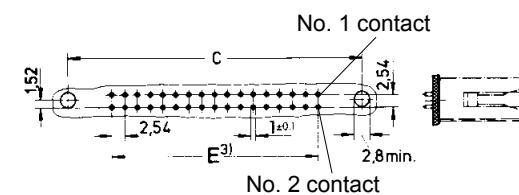

1) No polarization slot for 6, 10 or 14 way male header

2) No polarization slot for 6 way male header

3) Pitch tolerance: ± 0.1

Number of contacts

6-64

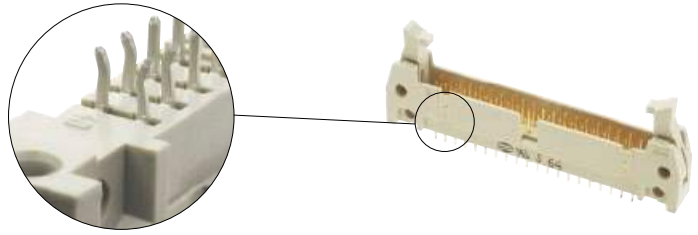

SMC male header with straight solder pins, kinked

Identification	No. of contacts	Part number		
		Without levers	With short levers	With long levers
SMC male header with straight solder pins, kinked Length: 2.9 mm	6	09 19 506 □ 024	09 19 506 □ 014	09 19 506 □ 004
	10	09 19 510 □ 024	09 19 510 □ 014	09 19 510 □ 004
	14	09 19 514 □ 024	09 19 514 □ 014	09 19 514 □ 004
	16	09 19 516 □ 024	09 19 516 □ 014	09 19 516 □ 004
	20	09 19 520 □ 024	09 19 520 □ 014	09 19 520 □ 004
	24	09 19 524 □ 024	09 19 524 □ 014	09 19 524 □ 004
	26	09 19 526 □ 024	09 19 526 □ 014	09 19 526 □ 004
	30	09 19 530 □ 024	09 19 530 □ 014	09 19 530 □ 004
	34	09 19 534 □ 024	09 19 534 □ 014	09 19 534 □ 004
	40	09 19 540 □ 024	09 19 540 □ 014	09 19 540 □ 004
	50	09 19 550 □ 024	09 19 550 □ 014	09 19 550 □ 004
	60	09 19 560 □ 024	09 19 560 □ 014	09 19 560 □ 004
	64	09 19 564 □ 024	09 19 564 □ 014	09 19 564 □ 004

SEK

* Not normally kept in stock
For accessories see page 08.48
For dimensions see page 08.43

For performance level 3 please specify digit 7*
For performance level 2 please specify digit 6*
S4 = 0.76 µm (30 µinch) Au or PdNi equivalent 5*



Number of contacts

6-64

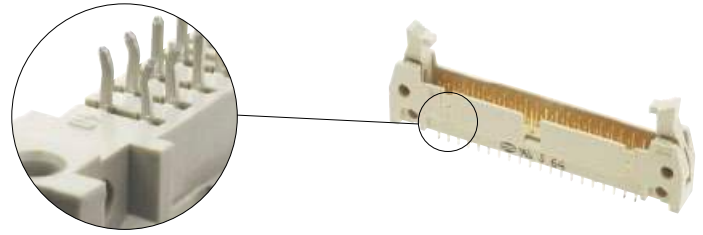

SMC male header with straight solder pins, kinked

Identification

Drawing

Dimensions in mm

SMC male header

No. of contacts	A	C	D	E	F	G
6	26.9	22.86	12.45	2.54 x 2 = 5.08	36.9	40.3
10	32.0	27.94	17.53	2.54 x 4 = 10.16	42.0	45.4
14	37.1	33.02	22.61	2.54 x 6 = 15.24	47.1	50.4
16	39.6	35.56	25.15	2.54 x 7 = 17.78	49.6	53.0
20	44.7	40.64	30.23	2.54 x 9 = 22.86	54.7	58.1
24	49.8	45.72	35.91	2.54 x 11 = 27.94	59.8	63.2
26	52.3	48.26	37.85	2.54 x 12 = 30.48	62.3	65.7
30	57.7	53.34	43.83	2.54 x 14 = 35.56	68.2	68.6
34	62.5	58.42	48.01	2.54 x 16 = 40.64	72.5	75.8
40	70.1	66.04	55.63	2.54 x 19 = 48.26	80.1	83.5
50	82.8	78.74	68.33	2.54 x 24 = 60.96	92.8	96.2
60	95.5	91.44	81.03	2.54 x 29 = 73.66	105.5	108.9
64	100.6	96.52	86.11	2.54 x 31 = 78.74	110.6	113.9

Short levers

for use with female connector without strain relief clamp

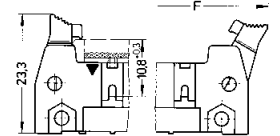
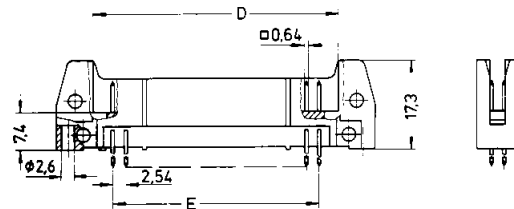

Long levers

for use with female connector with strain relief clamp

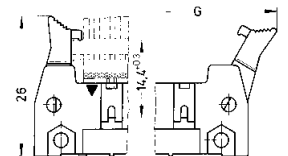
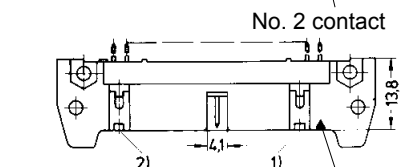
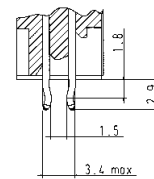
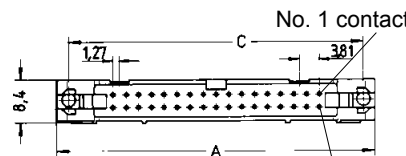

Marking No. 1 contact

No. 1 contact

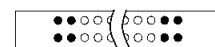
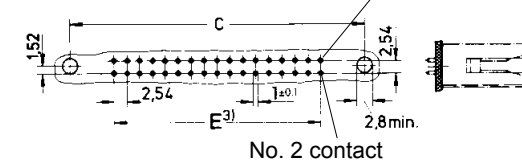

Board drillings

● Kinked contact: pcb thickness from 1.50 to 1.94 mm after Cu + Sn plating with non-remelted through holes \varnothing 0.80 to \varnothing 0.95 mm. Max. insertion force = 125 N. Min. retention force = 6 N.

○ Non-kinked contact: Solder pins for pcb connections \varnothing 1 ± 0.1 mm as per IEC 60603-13.

1) No polarization slot for 6, 10 or 14 way male header

2) No polarization slot for 6 way male header

3) Pitch tolerance: ± 0.1

Number of contacts

6-64

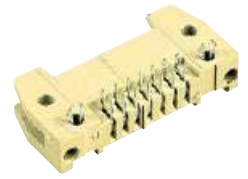

SMC male header with angled solder pins and board lock

Identification	No. of contacts	Part number		
		Without levers	With short levers	With long levers
SMC male header with angled solder pins and pcb board lock Length: 2.9 mm for 1.6 mm pcb thickness To hold the connector on the pcb before the soldering process, two board locks have been added on the male header with angled solder pins.	6	09 19 506 □ 973*	09 19 506 □ 963*	09 19 506 □ 953*
	10	09 19 510 □ 973*	09 19 510 □ 963*	09 19 510 □ 953*
	14	09 19 514 □ 973*	09 19 514 □ 963*	09 19 514 □ 953*
	16	09 19 516 □ 973*	09 19 516 □ 963*	09 19 516 □ 953*
	20	09 19 520 □ 973*	09 19 520 □ 963*	09 19 520 □ 953*
	24	09 19 524 □ 973*	09 19 524 □ 963*	09 19 524 □ 953*
	26	09 19 526 □ 973*	09 19 526 □ 963*	09 19 526 □ 953*
	30	09 19 530 □ 973*	09 19 530 □ 963*	09 19 530 □ 953*
	34	09 19 534 □ 973*	09 19 534 □ 963*	09 19 534 □ 953*
	40	09 19 540 □ 973*	09 19 540 □ 963*	09 19 540 □ 953*
	50	09 19 550 □ 973*	09 19 550 □ 963*	09 19 550 □ 953*
	60	09 19 560 □ 973*	09 19 560 □ 963*	09 19 560 □ 953*
	64	09 19 564 □ 973*	09 19 564 □ 963*	09 19 564 □ 953*

SEK

* Not normally kept in stock

For performance level 3 please specify digit 7
 For performance level 2 please specify digit 6
 S4 = 0.76 µm (30 µinch) Au or PdNi equivalent

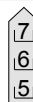

Number of contacts

6-64

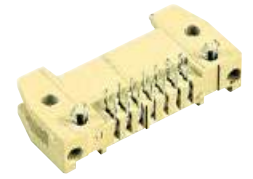

SMC male header with angled solder pins and board lock

Identification

Drawing

Dimensions in mm

SMC male header

No. of contacts	A	B	D	E	F	G
6	26.9	16.76	12.45	2.54 x 2 = 5.08	36.9	40.3
10	32.0	21.84	17.53	2.54 x 4 = 10.16	42.0	45.4
14	37.1	26.92	22.61	2.54 x 6 = 15.24	47.1	50.4
16	39.6	29.46	25.15	2.54 x 7 = 17.78	49.6	53.0
20	44.7	34.54	30.23	2.54 x 9 = 22.86	54.7	58.1
24	49.8	39.62	35.91	2.54 x 11 = 27.94	59.8	63.2
26	52.3	42.16	37.85	2.54 x 12 = 30.48	62.3	65.7
30	57.7	47.24	43.83	2.54 x 14 = 35.56	68.2	68.6
34	62.5	52.32	48.01	2.54 x 16 = 40.64	72.5	75.8
40	70.1	59.94	55.63	2.54 x 19 = 48.26	80.1	83.5
50	82.8	72.64	68.33	2.54 x 24 = 60.96	92.8	96.2
60	95.5	85.34	81.03	2.54 x 29 = 73.66	105.5	108.9
64	100.6	90.42	86.11	2.54 x 31 = 78.74	110.6	113.9

Short levers

for use with female connector without strain relief clamp

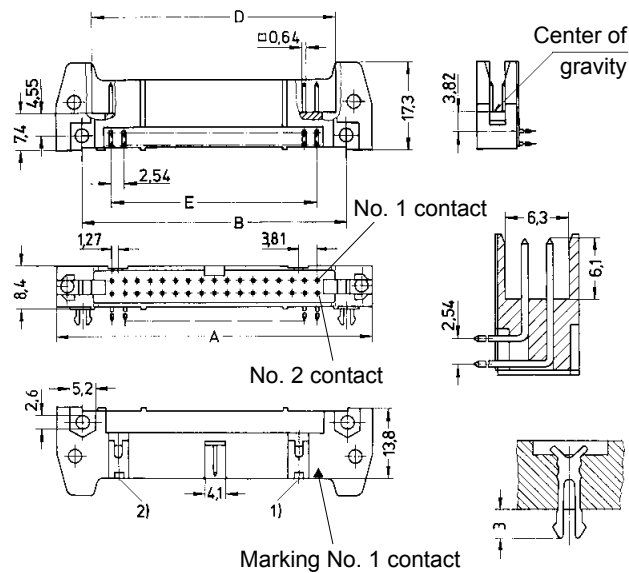

Long levers

for use with female connector with strain relief clamp

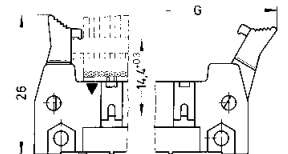

Board drillings

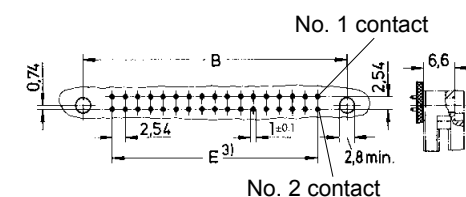

For accessories see page 08.48

1) No polarization slot for 6, 10 or 14 way male header

2) No polarization slot for 6 way male header

3) Pitch tolerance: ± 0.1

Number of contacts

6-64



Tape & Reel packaging



SMC low-profile male header, angled solder pins

Identification	No. of contacts	Part number	Drawing	Dimensions in mm
----------------	-----------------	-------------	---------	------------------

SMC male header with angled solder pins

Length: 2.9 mm
Colour: Beige
Packaging: Carton

6	09 19 506	└ 323
10	09 19 510	└ 323
14	09 19 514	└ 323
16	09 19 516	└ 323
20	09 19 520	└ 323
26	09 19 526	└ 323
30	09 19 530	└ 323
34	09 19 534	└ 323
40	09 19 540	└ 323
50	09 19 550	└ 323
60	09 19 560	└ 323
64	09 19 564	└ 323

No. of contacts	A	B	E
6	15.2	12.78	2.54 x 2 = 5.08
10	20.3	17.86	2.54 x 4 = 10.16
14	25.4	22.94	2.54 x 6 = 15.24
16	27.9	25.48	2.54 x 7 = 17.78
20	33.0	30.56	2.54 x 9 = 22.86
26	40.6	38.18	2.54 x 12 = 30.48
30	45.72	43.26	2.54 x 14 = 35.56
34	50.8	48.34	2.54 x 16 = 40.64
40	58.4	55.96	2.54 x 19 = 48.26
50	71.3	68.66	2.54 x 24 = 60.96
60	84.0	81.36	2.54 x 29 = 73.66
64	89.1	86.44	2.54 x 31 = 78.74

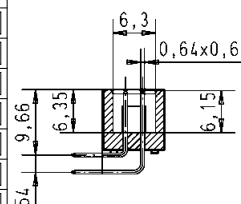

Solder pins for 1 ± 0.1 mm dia. hole

Colour: Beige
Packaging: Tape & Reel

Vacuum plate for pick & place process

6	09 19 506	└ 323 740
10	09 19 510	└ 323 740
14	09 19 514	└ 323 740
16	09 19 516	└ 323 740
20	09 19 520	└ 323 740
26	09 19 526	└ 323 740
30	09 19 530	└ 323 740
34	09 19 534	└ 323 740
40	09 19 540	└ 323 740

Colour: Black
Packaging: Tape & Reel

Vacuum plate for pick & place process

6	09 19 506	└ 323 741
10	09 19 510	└ 323 741
14	09 19 514	└ 323 741
16	09 19 516	└ 323 741
20	09 19 520	└ 323 741
26	09 19 526	└ 323 741
30	09 19 530	└ 323 741
34	09 19 534	└ 323 741
40	09 19 540	└ 323 741

For performance level 3 please specify digit 7
For performance level 2 please specify digit 6
S4 = 0.76 µm (30 µinch) Au or PdNi equivalent



Marking No. 1 contact

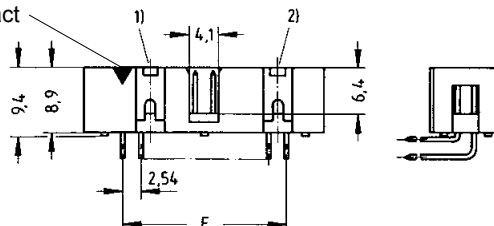

No. 2 contact

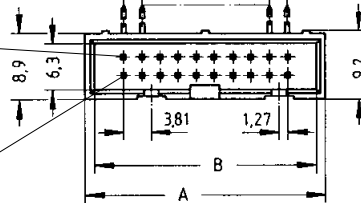

No. 1 contact

No. 2 contact

No. 1 contact

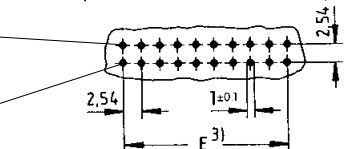

Identification	Part number	Drawing	Dimensions in mm
----------------	-------------	---------	------------------

Locking lever for female connector with strain relief in conjunction with low-profile male header

09 18 000 9905⁴⁾

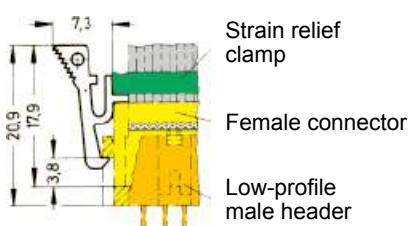

When the security of latching is required and space is a premium, these locking levers can be fitted onto the strain relief of the HARTING female connector.

* Not normally kept in stock

1) No polarization slot for 6, 10 or 14 way male header
2) No polarization slot for 6 way male header

3) Pitch tolerance: ± 0.1
4) Order 2 per female connector

Number of contacts

6-64



Tape & Reel packaging



SMC low-profile male header, straight solder pins

Identification	No. of contacts	Part number	Drawing	Dimensions in mm
----------------	-----------------	-------------	---------	------------------

SMC male header with straight solder pins

Length: 2.9 mm
Colour: Beige
Packaging: Carton

6	09 19 506	324
10	09 19 510	324
14	09 19 514	324
16	09 19 516	324
20	09 19 520	324
26	09 19 526	324
30	09 19 530	324
34	09 19 534	324
40	09 19 540	324
50	09 19 550	324
60	09 19 560	324
64	09 19 564	324

No. of contacts	A	B	E
6	15.2	12.78	2.54 x 2 = 5.08
10	20.3	17.86	2.54 x 4 = 10.16
14	25.4	22.94	2.54 x 6 = 15.24
16	27.9	25.48	2.54 x 7 = 17.78
20	33.0	30.56	2.54 x 9 = 22.86
26	40.6	38.18	2.54 x 12 = 30.48
30	45.72	43.26	2.54 x 14 = 35.56
34	50.8	48.34	2.54 x 16 = 40.64
40	58.4	55.96	2.54 x 19 = 48.26
50	71.3	68.66	2.54 x 24 = 60.96
60	84.0	81.36	2.54 x 29 = 73.66
64	89.1	86.44	2.54 x 31 = 78.74

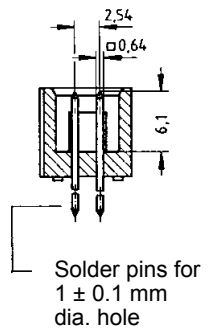

Colour: Beige
Packaging: Tape & Reel

6	09 19 506	324 740
10	09 19 510	324 740
14	09 19 514	324 740
16	09 19 516	324 740
20	09 19 520	324 740
26	09 19 526	324 740
30	09 19 530	324 740
34	09 19 534	324 740
40	09 19 540	324 740

Colour: Black
Packaging: Tape & Reel

6	09 19 506	324 741
10	09 19 510	324 741
14	09 19 514	324 741
16	09 19 516	324 741
20	09 19 520	324 741
26	09 19 526	324 741
30	09 19 530	324 741
34	09 19 534	324 741
40	09 19 540	324 741

For performance level 3 please specify digit 7
For performance level 2 please specify digit 6
S4 = 0.76 µm (30 µinch) Au or PdNi equivalent



Marking No. 1 contact

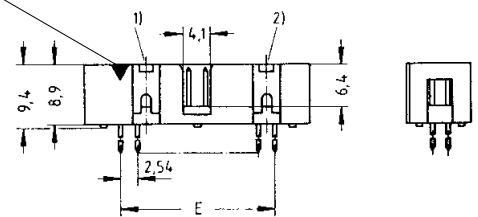

No. 2 contact

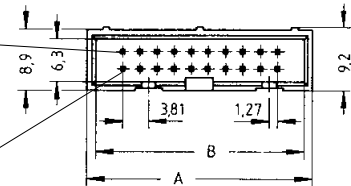

No. 1 contact

No. 2 contact

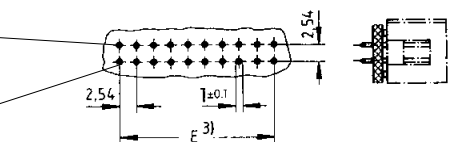

No. 1 contact

Identification	Part number	Drawing	Dimensions in mm
----------------	-------------	---------	------------------

Locking lever for female connector with strain relief in conjunction with low-profile male header

09 18 000 99054)

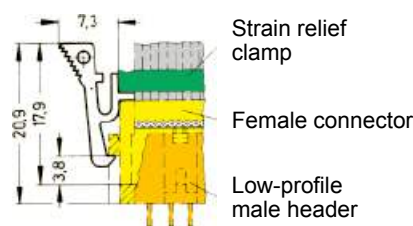

When the security of latching is required and space is a premium, these locking levers can be fitted onto the strain relief of the HARTING female connector.

* Not normally kept in stock

1) No polarization slot for 6, 10 or 14 way male header
2) No polarization slot for 6 way male header

3) Pitch tolerance: ± 0.1
4) Order 2 per female connector

SEK

Accessories

Identification	Part number	Drawing	Dimensions in mm
----------------	-------------	---------	------------------

<p>Polarization key</p> <p>1) Part number comprises 2 keys</p>	<p>09 18 500 9902¹⁾</p>		
---	------------------------------------	--	--

<p>Locking lever (snaps into place, can be fitted whenever required)</p> <p>2) Order 2 per male header</p>	<p>Long: 09 19 000 9903²⁾</p> <p>Short: 09 19 000 9904²⁾</p>	<p>Long</p> <p>Short</p> <p>For use with female connector <u>with</u> strain relief clamp</p> <p>For use with female connector <u>without</u> strain relief clamp</p>	
---	--	---	--

<p>Fixing screws for 1.6 mm P.C. board</p> <p>3) Part number comprises 50 pieces</p>	<p>09 18 000 9906³⁾</p>	<p>For connectors with part numbers 09 18 5xx x9xx: screwing torque 0.2 Nm 09 19 5xx x9xx: screwing torque 0.4 – 0.5 Nm</p> <p>Screw material: Steel (Inox A2)</p> <p>Plating: Nickel</p>	
---	------------------------------------	---	--

<p>Coding system with loss of contact</p> <p>4) Part number comprises 6 code pins</p>	<p>Code pin 09 18 000 9901⁴⁾</p> <p>Removal tool for male contacts 09 99 000 0133</p>	<p>To avoid cross-plugging adjacent connectors a coding system is required. A code pin is inserted into the appropriate cavity in the female connector. The corresponding male contact is removed by a special removal tool.</p>	
--	--	--	--

SEK

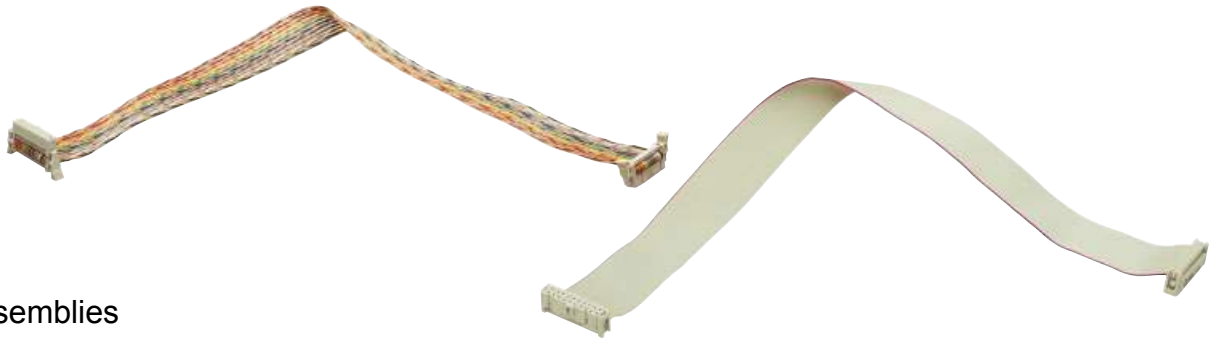

Cable assemblies

Identification	Part number	Drawing	Dimensions in mm
<p>Cable assembly SEK 20-pole</p> <p>Cable: Flat cable, 10 twisted pairs, AWG 28/7, 1.27 mm pitch</p> <p>Wiring: 1:1</p> <p>Length: L = 0.5 m L = 1.0 m L = 1.5 m</p>	<p>33 18 243 0500 060 33 18 243 1000 062 33 18 243 1500 068</p>		
<p>Cable assembly SEK 40-pole</p> <p>Cable: Flat cable, 20 twisted pairs, AWG 28/7, 1.27 mm pitch</p> <p>Wiring: 1:1</p> <p>Length: L = 0.5 m L = 1.0 m L = 1.5 m</p>	<p>33 18 243 0500 055 33 18 243 1000 057 33 18 243 1500 069</p>		
<p>Cable assembly SEK 10-pole</p> <p>Cable: Flat cable, grey, 10 wires, AWG 28/7, 1.27 mm pitch</p> <p>Wiring: 1:1</p> <p>Length: L = 0.1 m L = 0.2 m L = 0.5 m L = 0.8 m L = 1.0 m</p>	<p>33 18 243 0100 063 33 18 243 0200 064 33 18 243 0500 065 33 18 243 0800 066 33 18 243 1000 067</p>		



SEK

Cables for insulation displacement termination

Identification	No. of contacts	Part number	Drawing	Dimensions in mm			
Flat cable grey UL AWM-style 2651 CSA	6	09 18 006 700 □	<p>Conductor material _____ Copper tinned Gauge _____ AWG 28/7 0.089 mm² Voltage rating _____ 300 V_{r.m.s.} Current rating at 25 °C _____ 2.1 A max. Capacity unbalanced _____ 45.9 pF/m Impedance unbalanced _____ 105 Ω Propagation delay _____ 4.9 ns/m nominal Insulation material _____ PVC Temperature rating (operating) _____ -20 °C ... +105 °C Temperature rating (static) _____ -30 °C ... +105 °C Flammability rating _____ UL: VW-1 Insulation resistance _____ > 100 MΩ/km</p>				
	9	09 18 009 700 □					
	10	09 18 010 700 □					
	14	09 18 014 700 □					
	15	09 18 015 700 □					
	16	09 18 016 700 □					
	18	09 18 018 700 □					
	20	09 18 020 700 □					
	24	09 18 024 700 □					
	25	09 18 025 700 □					
	26	09 18 026 700 □					
	28	09 18 028 700 □					
	30	09 18 030 700 □					
	34	09 18 034 700 □					
	37	09 18 037 700 □					
	40	09 18 040 700 □					
	50	09 18 050 700 □					
	60	09 18 060 700 □					
	64	09 18 064 700 □					
	Length per reel						
30.48 m (100 feet)	1						
100 m (328 feet)	4						
Flat cable grey non-halogenated UL style 21447 for VW-1	6	09 18 006 700 □ 900	<p>Conductor material _____ Copper tinned Gauge _____ AWG 28/7 0.089 mm² Voltage rating _____ 300 V_{r.m.s.} Current rating _____ 1.3 A Capacity unbalanced _____ 42.6 pF/m at 1 MHz Impedance unbalanced _____ 100 Ω Inductance _____ 0.56 μH/m Propagation delay _____ 4.8 ns/m Insulation material _____ Non-halogenated flame retardent Polyolefin Temperature rating _____ -40 °C ... +80 °C Insulation resistance _____ 10000 MΩ/km</p>				
	9	09 18 009 700 □ 900					
	10	09 18 010 700 □ 900					
	14	09 18 014 700 □ 900					
	15	09 18 015 700 □ 900					
	16	09 18 016 700 □ 900					
	18	09 18 018 700 □ 900					
	20	09 18 020 700 □ 900					
	24	09 18 024 700 □ 900					
	25	09 18 025 700 □ 900					
	26	09 18 026 700 □ 900					
	28	09 18 028 700 □ 900					
	34	09 18 034 700 □ 900					
	37	09 18 037 700 □ 900					
	40	09 18 040 700 □ 900					
	50	09 18 050 700 □ 900					
	60	09 18 060 700 □ 900					
	64	09 18 064 700 □ 900					
	Length per reel						
	30.48 m (100 feet)	1					

SEK

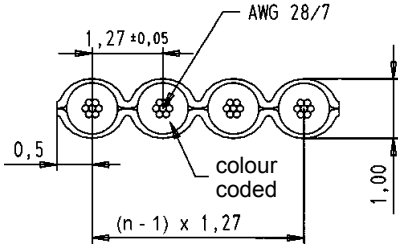
Cables for insulation displacement termination

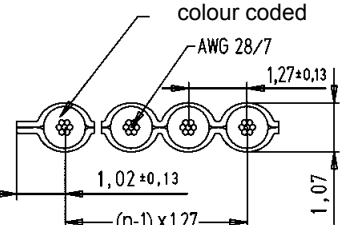
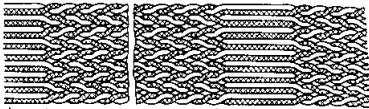
Identification	No. of contacts	Part number	Drawing	Dimensions in mm	
Flat cable colour coded Length per reel 30.48 m (100 feet) UL AWM-style 2651	6	09 18 006 7005	 <p>Colour code sequence (in 10 steps) brown, red, orange, yellow, green, blue, violet, grey, white, black</p>  <p>Conductor material _____ Copper tinned Gauge _____ AWG 28/7 0.09 mm² Voltage rating _____ 300 V_{r.m.s.} Current rating at 25 °C _____ 2.1 A max. Conductor resistance _____ 221 mΩ/m Capacity unbalanced _____ 42.7 pF/m Impedance unbalanced _____ 105 Ω Inductance unbalanced _____ 0.68 μH/m Signal delay _____ 4.9 ns/m Insulation material _____ PVC Temperature rating (operating) _____ -20 °C ... +105 °C Temperature rating (static) _____ -30 °C ... +105 °C Flammability rating _____ UL: VW 1 Insulation resistance _____ 100 MΩ/km</p>		
	9	09 18 009 7005			
	10	09 18 010 7005			
	14	09 18 014 7005			
	15	09 18 015 7005			
	16	09 18 016 7005			
	18	09 18 018 7005			
	20	09 18 020 7005			
	24	09 18 024 7005			
	25	09 18 025 7005			
	26	09 18 026 7005			
	28	09 18 028 7005			
	30	09 18 030 7005			
	34	09 18 034 7005			
	37	09 18 037 7005			
	40	09 18 040 7005			
	50	09 18 050 7005			
60	09 18 060 7005				
64	09 18 064 7005				
Flat cable twisted pair Length per reel 30.48 m (100 feet) UL AWM-style 20 130	10	09 18 010 7006	  <p>Conductor material _____ Copper tinned Gauge _____ AWG 28/7 0.089 mm² Voltage rating _____ 300 V_{r.m.s.} Conductor resistance _____ 221 mΩ/m Capacity unbalanced _____ 49 pF/m Impedance unbalanced _____ 105 Ω Signal delay _____ 5.2 ns/m Insulation material _____ PVC Temperature rating _____ -20 °C ... +105 °C Flammability rating _____ UL: VW 1 Insulation resistance _____ 10⁴ MΩ/km</p>		
	14	09 18 014 7006			
	16	09 18 016 7006			
	20	09 18 020 7006			
	26	09 18 026 7006			
	34	09 18 034 7006			
	40	09 18 040 7006			
	50	09 18 050 7006			
	60	09 18 060 7006			
	64	09 18 064 7006			

SEK

Important: always store reel vertically

Cables for insulation displacement termination

Identification	No. of contacts	Part number	Drawing	Dimensions in mm
Round flat cable				
with screening (shielding)				
	9	09 18 009 70		ø max. 6.86
	10	09 18 010 70		6.86
	14	09 18 014 70		7.37
	15	09 18 015 70		7.62
UL listed PLCC CL2	16	09 18 016 70		7.87
CSA certified AWM FT-1	20	09 18 020 70		8.38
	25	09 18 025 70		9.14
	26	09 18 026 70		9.14
	34	09 18 034 70		10.16
	37	09 18 037 70		10.41
	40	09 18 040 70		10.92
Length per reel	50	09 18 050 70		12.19
30.48 m (100 feet)	60	09 18 060 70		13.21
	64	09 18 064 70		13.46
	9	09 18 009 7008	6.35	
	10	09 18 010 7008	6.35	
	14	09 18 014 7008	6.60	
	15	09 18 015 7008	6.86	
UL listed PLCC CL2	16	09 18 016 7008	7.11	
CSA certified AWM FT-1	20	09 18 020 7008	7.62	
	25	09 18 025 7008	8.38	
Length per reel	26	09 18 026 7008	8.38	
30.48 m (100 feet)	34	09 18 034 7008	9.40	
	37	09 18 037 7008	9.65	
	40	09 18 040 7008	10.16	
	50	09 18 050 7008	11.43	
	60	09 18 060 7008	12.45	
	64	09 18 064 7008	12.70	

No. of contacts	a	b	c
9 to 26	19.05	19.05	38.10
34 to 64	38.10	19.05	57.15

Conductor material _____ Copper tinned
 Gauge _____ AWG 28/7 0.089 mm²
 Voltage rating _____ 300 V_{r.m.s.}
 Conductor resistance _____ 225 mΩ/m
 Capacity unbalanced _____ 78.7 pF/m
 Impedance unbalanced _____ 75 Ω
 Signal delay _____ 5.25 ns/m nom.
 Insulation material _____ PVC
 Temperature rating _____ -20 °C ... +105 °C
 Flammability rating _____ UL: VW 1
 Insulation resistance _____ 10⁴ MΩ/km

SEK

* Not normally kept in stock
 1) Only available for 10, 14, 37, 40 and 64 contacts
 Important: always store reels vertically

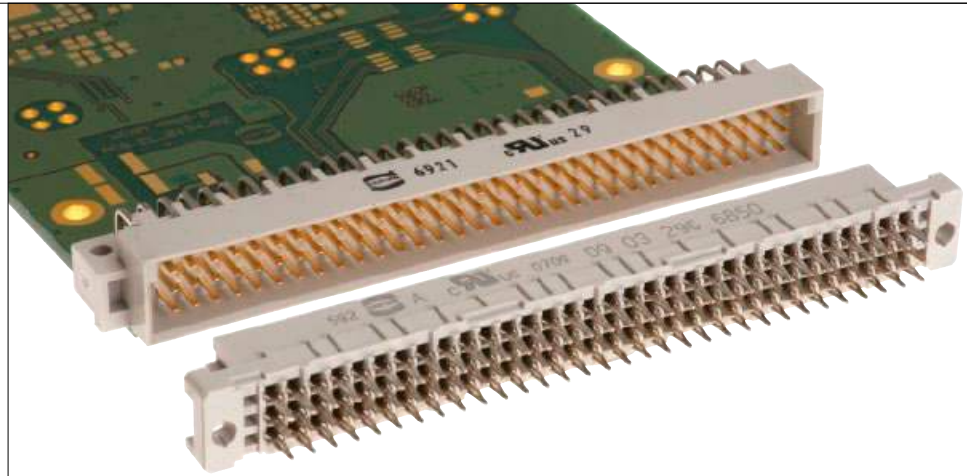

Connectors that comply with DIN 41 612 have been in use for years for both board-to-board applications and cable-to-board applications. Their robustness and universality are legendary. The classic signal connectors are supplemented by power solutions for allowing insertion of up to 40 A. Plastic, metallized and full metal housings, used in combination with shielded or unshielded cables with a high number of poles, are available for cable-to-board connectors. HARTING offers a wide range of DIN 41 612 connectors and accessories. The following catalogue pages contain an extract from the DIN 41 612 connector program. The complete DIN 41 612 connector program for data, signals and power can be found in the complete DIN 41 612 catalogue.

Application profile:

CONNECTION TYPE		ENVIRONMENT		APPLICATION						
Board to Board	Cable/Wire to Board	IP20	IP65 / IP67	Data	Signal	Power	high performance			
				Data transfer rate	Shielding	Number of contacts, contact density	Voltage, working current			
Cable termination			PCB termination			Application standard				
<i>Han-Quick Lock®</i>	<i>IDC</i>	<i>Crimp</i>	<i>THT</i>	<i>SMC</i>	<i>SMT</i>					
<i>Screw</i>	<i>Cage clamp</i>	<i>Axial screw</i>	<i>Press-in</i>							
				<i>Separate housing</i>		<i>Integrated housing</i>				

Contents

	Page
Overview DIN Signal	09.04
Overview <i>har-bus</i> [®] 64	09.06
Application examples	09.07
Overview DIN Power	09.08
Overview shell housings	09.10
Male and female connectors with pcb fixings	09.11

In devices for industrial automation and measurement techniques, the DIN 41 612 connector is the standard for board-to-board and cable-to-board connections as both data and power connectors. HARTING offers a wide range of standard connectors complying with DIN 41 612 and IEC 60 603-2, as well as a great selection of complementary types and customer specific solutions. Depending on the application, the 3 to 160 way connectors are offered with various termination methods, each contact capable of carrying from 2 A to 40 A.

HARTING differentiates between DIN Signal and DIN Power connectors depending on the maximum allowed working current per contact: up to 2 A for DIN Signal and over 2 A for DIN Power connectors.

HARTING's range *har-bus*[®] 64 features 160 contacts and is an extension of the 3 row 96 way DIN 41 612 C type range with 2 additional rows. The 5 row *har-bus*[®] 64 connector is 100 % forwards and backwards compatible with the type C connectors according to DIN 41 612. The design of male and female connectors allows the mating of any combination of the 5 or the 3 row variants.

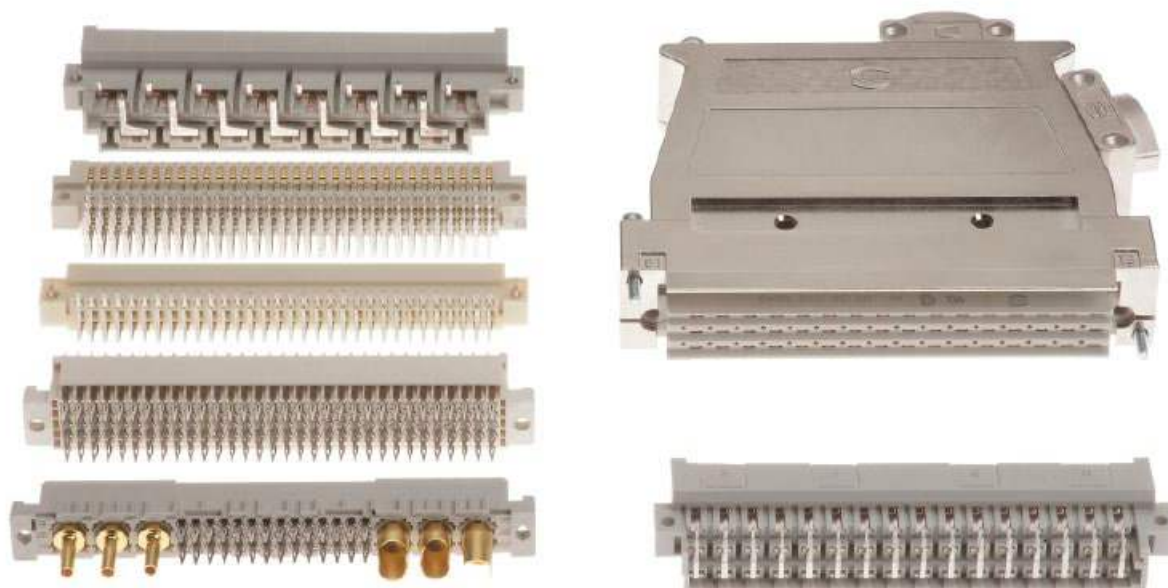

The design of the *har-bus*[®] 64 female allows mating of any combinations of the 5 or 3 row standard male connectors. It is also possible to mate 5 row male connectors with 3 row female connectors.

This kind of backwards compatibility allows the user the staged transition to a higher performance category and simultaneous use of daughter cards in the slots of the previous generation.

Therefore all existing bus systems, for which the 3 row C96 pin connectors are no longer sufficient, can be adapted to the latest requirements without a complete system redesign.

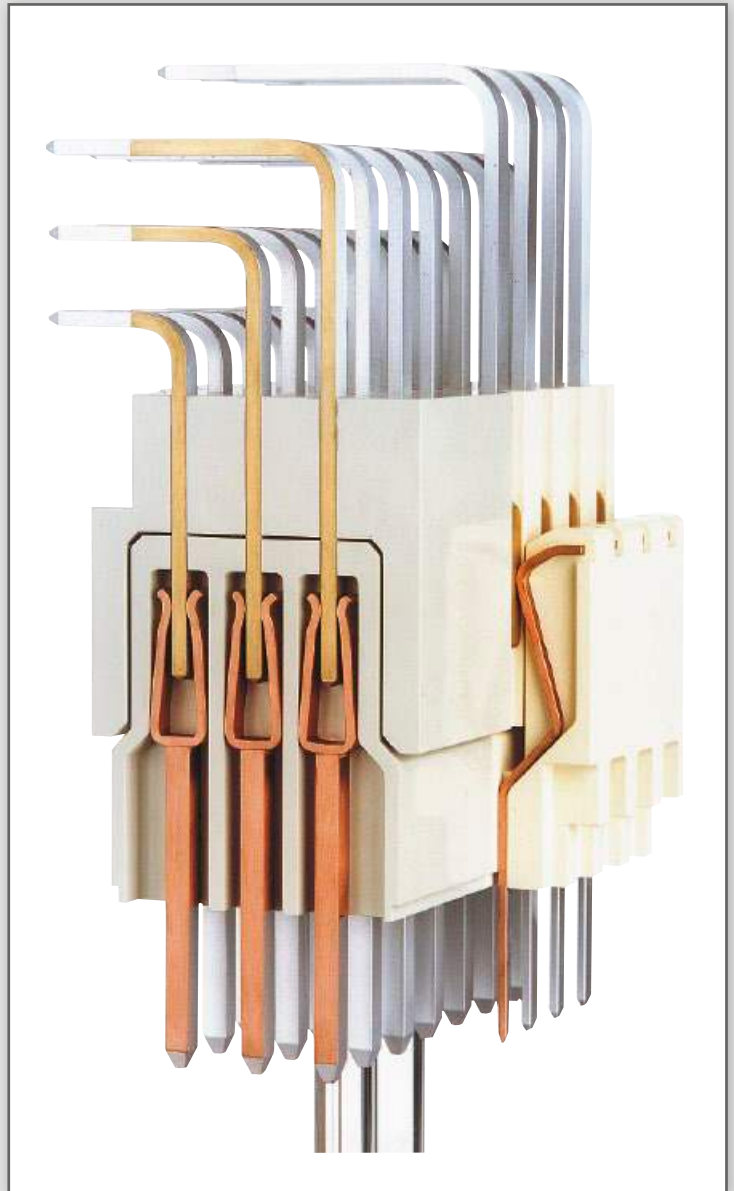

DIN
41612

Variety of DIN 41 612 types

Due to the large variety of complementary types, accessories and different kinds of shell housings which are available in plastic, metallized plastic and full metal, DIN 41 612 connector range is considered to be ideal for your robust, reliable and cost-efficient connectivity solution.

The special requirements of industrial electronics can be satisfied with standard types.



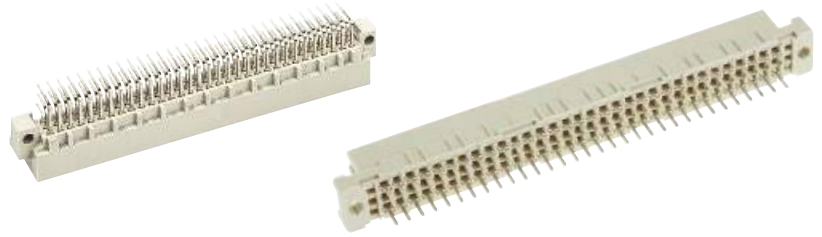

For detailed information see catalogue DIN 41 612 or www.HARTING.com

Type	Maximum number of contacts	Image		Termination							
				Solder	Reflow Soldering (SMC)	Solder lug	Press-in	Crimp	Wire wrap	IDC	
B	64		male	3.0 mm	3.0 mm						
			female	2.9 mm 4.5 mm 13.0 mm	2.9 mm 4.5 mm	X	4.5 mm 13.2 mm	X	13.0 mm	X	
2 B	32		male	3.0 mm	3.0 mm						
			female	2.9 mm 4.5 mm	2.9 mm 4.5 mm		4.5 mm		13.0 mm		
3 B*	20		male	3.0 mm	3.0 mm						
			female	2.9 mm 4.5 mm	2.9 mm		4.5 mm				
C	96		male	3.0 mm	3.0 mm						
			female	2.9 mm 4.5 mm 13.0 mm	2.9 mm 4.5 mm	X	4.5 mm 13.2 mm 17.0 mm	X	13.0 mm	X	
2 C	48		male	3.0 mm	3.0 mm						
			female	2.9 mm 4.5 mm 13.0 mm	2.9 mm 4.5 mm	X	3.7 mm 4.5 mm	X	13.0 mm		
3 C*	30		male	3.0 mm	3.0 mm						
			female	2.9 mm 4.5 mm	2.9 mm		4.5 mm	X			
M	78 + 2 60 + 4 42 + 6 24 + 8		male	3.0 mm							
			female	2.9 mm 4.5 mm			4.5 mm				

* Available with and without flange

DIN 41 612

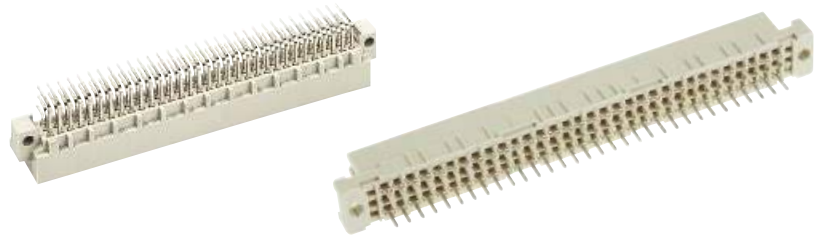

For detailed information see catalogue DIN 41612 or www.HARTING.com

Type	Maximum number of contacts	Image		Termination						
				Solder	Reflow Soldering (SMC)	Solder lug	Press-in	Crimp	Wire wrap	IDC
M flat	78 + 2 60 + 4 42 + 6 24 + 8		female	2.9 mm 4.5 mm			4.5 mm			
M inverse	78 + 2 60 + 4 42 + 6 24 + 8 6 + 10		male	2.5 mm 4.0 mm			5.5 mm 13.0 mm		13.0 mm	
			female	3.0 mm						
Q	64		male	2.5 mm 4.0 mm 13.0 mm			5.0 mm 13.0 mm		13.0 mm 17.0 mm	
			female	3.0 mm						
2 Q	32		male	2.5 mm 4.0 mm 13.0 mm			5.0 mm		13.0 mm	
			female	3.0 mm						
3 Q*	20		male	2.5 mm 4.0 mm 13.0 mm	2.5 mm 4.0 mm 13.0 mm		5.0 mm 13.0 mm		13.0 mm	
R	96		male	2.5 mm 4.0 mm 13.0 mm	2.5 mm 4.0 mm 13.0 mm		5.0 mm 13.0 mm		13.0 mm	
			female	2.8 mm	2.8 mm					
R (HE 11)	96		male	2.5 mm 4.0 mm					13.0 mm	
			female	2.9 mm						
RM	96		male				5.0 mm 13.0 mm			
2 R	48		male	2.5 mm 4.0 mm 13.0 mm	2.5 mm 4.0 mm 13.0 mm		5.0 mm 13.0 mm		13.0 mm	
			female	3.0 mm						
3 R*	30		male	2.5 mm 4.0 mm 13.0 mm	2.5 mm 4.0 mm 13.0 mm		5.0 mm 13.0 mm		13.0 mm	

DIN 41612

* Available with and without flange

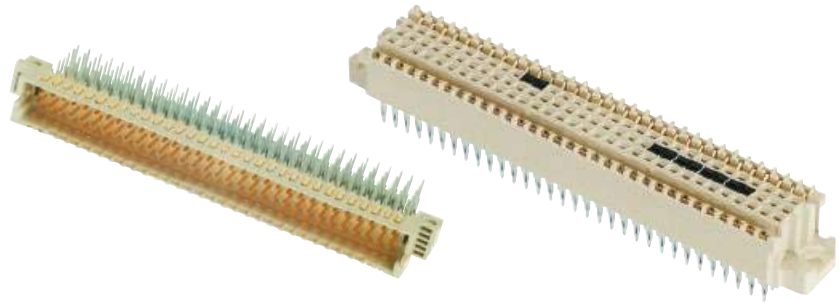

For detailed information see catalogue DIN 41 612 or www.HARTING.com

Type	Maximum number of contacts		Termination							
			Solder	Reflow Soldering (SMC)	Solder lug	Press-in	Crimp	Wire wrap	IDC	
harbus® 64	160		male	3.0 mm	3.0 mm					
			female	2.9 mm			3.7 mm 5.0 mm 17.0 mm	X		
			female with switches				4.5 / 5.0 mm			

harbus® 64 system description

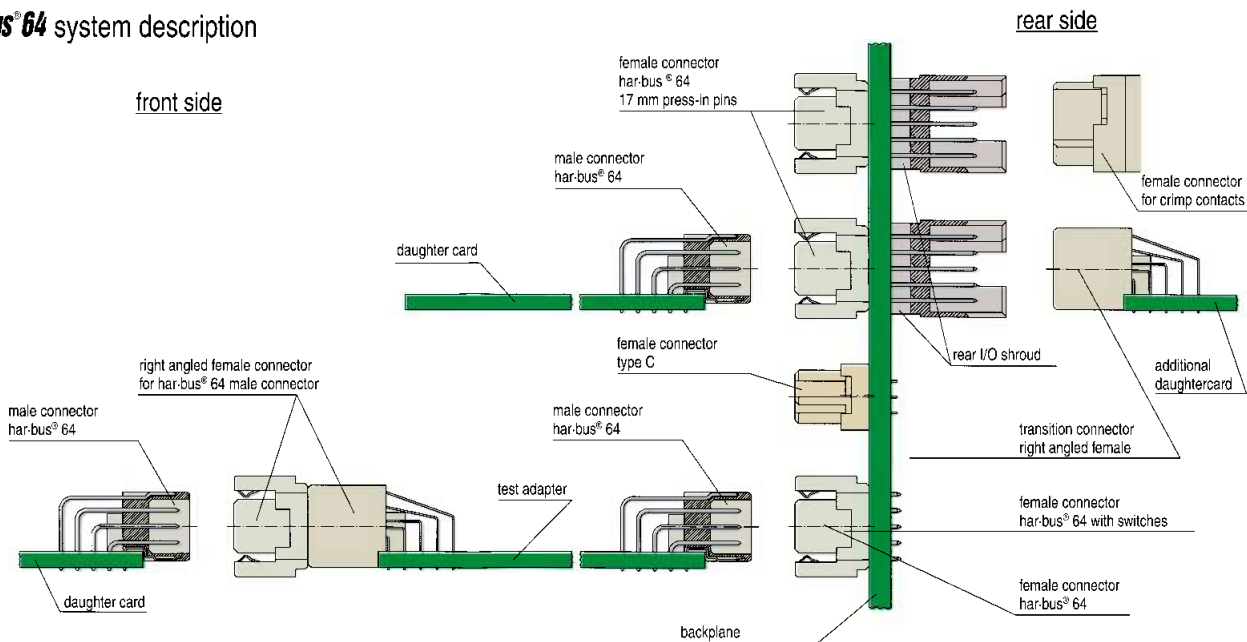

Technical characteristics DIN Signal / harbus® 64

Number of contacts	16 – 160	Insertion and withdrawal force	16-pol. ≤ 15 N 30-pol. ≤ 30 N 32-pol. ≤ 30 N 48-pol. ≤ 45 N 64-pol. ≤ 60 N 96-pol. ≤ 90 N 160-pol. ≤ 160 N
Contact spacing	2.54	Materials	thermoplastic resin, glass-fibre filled, UL 94-V0 Liquid Cristal Polymer (LCP), UL 94-V0 Poly Cyclohexylene Terephthalate (PCT), UL 94-V0 NFF classification up to F1/I2 copper alloy
Working current (all contacts are loaded)	2 A 1 A for harbus® 64 at 70 °C 1 A with insulation displacement 40 A max. type M	Mouldings	
Test voltage $U_{r.m.s}$	1 KV	Contacts	
Contact resistance	≤ 15 mΩ for solder and wire wrap connection ≤ 20 mΩ for crimp connection ≤ 20 mΩ harbus® 64 rows a,b,c ≤ 30 mΩ harbus® 64 rows z,d	Contact surface	
Insulation resistance	≥ 10 ¹⁰ Ω harbus® 64 ≥ 10 ¹² Ω DIN Signal	Contact zone	selectively plated according to performance level
Temperature range	-40 °C ... +105 °C for press-in connectors -55 °C ... +125 °C max. +240 °C for 15 s during reflow soldering (only SMC)		

Application 1

Female connector
09 03 296 6861



Backplane

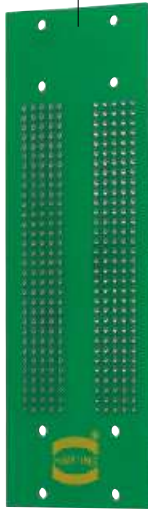

Pin shroud
09 03 000 9957



Locking lever
09 03 000 9914

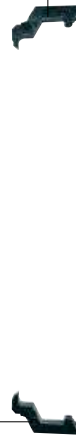

Female connector
09 03 264 6828



Female connector
09 03 096 3214



Application 2

Female connector
09 03 296 6862



Backplane

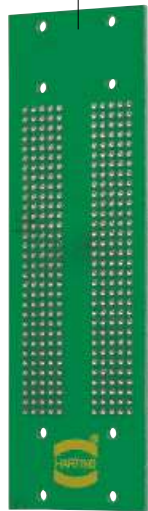

Pin shroud
09 03 000 9953



Locking lever
09 03 000 9913



Female connector
09 73 296 6801



Daughtercard

Application 3

Female connector
09 03 296 6861



Backplane

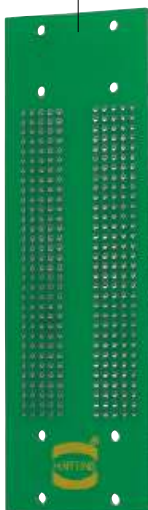

Pin shroud
09 03 000 9957



Fixing brackets
09 03 000 9921



Female connector
09 03 096 3214



Locking levers
left 09 02 000 9902
right 09 02 000 9903

Shell housing C
09 03 096 0501

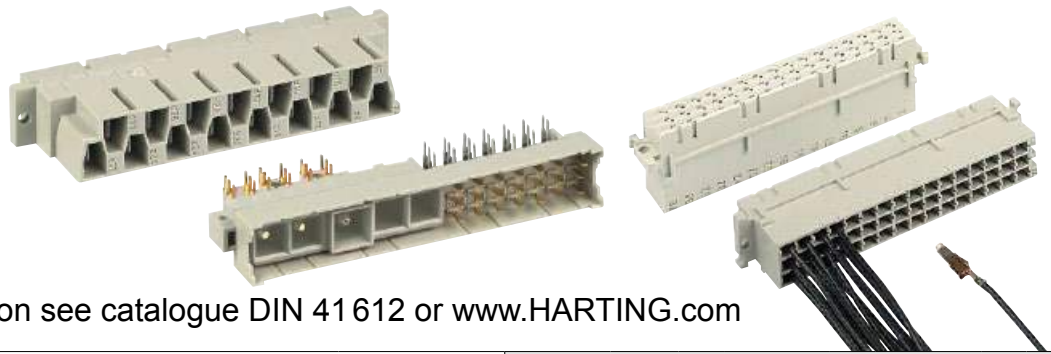

For detailed information see catalogue DIN 41 612 or www.HARTING.com

Type	Maximum number of contacts			Termination								
				Solder	Reflow Soldering (SMC)	Solder lug	Press-in	Crimp	Wire wrap	Faston	Cage clamp	
D	32		male	3.0 mm	X							
			female	2.9 mm 4.5 mm		X		X	20.0 mm			
E	48		male	3.0 mm	X							
			female	2.9 mm 4.5 mm		X	4.5 mm 11.5 mm	X	20.0 mm			
			Interface connector I	4.0 mm								
F	48		male	3.0 mm	X							
			female	3.7 mm 4.5 mm		X		X	22.0 mm			
F Low profile	48		female	3.7 mm 4.5 mm			4.5 mm 13.0 mm					
			Interface connector I	3.5 mm				X	22.0 mm			
F 9	9		male					X				
			female					X				
FM	45		male	3.0 mm				X				
			female	4.5 mm				X	22.0 mm			
2 F	24		female					X				
			Interface connector I					X				

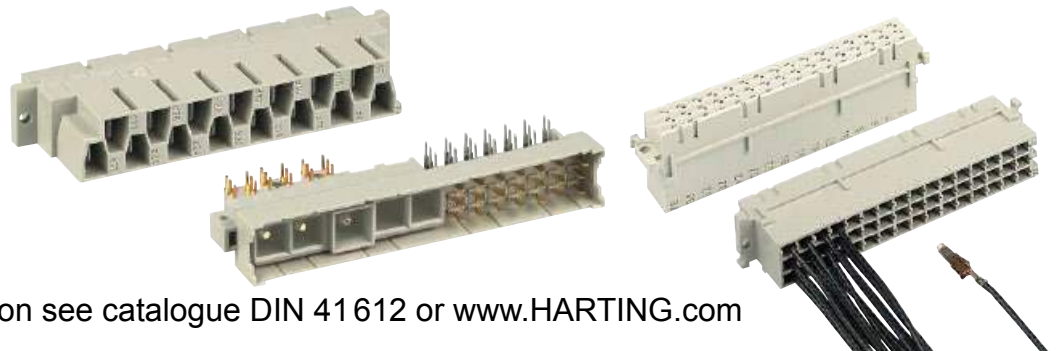

For detailed information see catalogue DIN 41612 or www.HARTING.com

Type	Maximum number of contacts	Image		Termination								
				Solder	Reflow Soldering (SMC)	Solder lug	Press-in	Crimp	Wire wrap	Faston	Cage clamp	
H	15		male	3.0 mm							X	
			female	2.7 mm 4.0 mm 5.5 mm 7.0 mm 10.0 mm			3.6 mm				X	X
H	16		male	3.0 mm								
			female								X	
H 3	3		male	3.0 mm								
			female	4.0 mm								
MH	24 + 7		male	3.0 mm							X	
			female	4.5 mm				X	22.0 mm			
MH	21 + 5		male	3.1 mm								
			female	3.2 mm								

DIN 41612

Technical characteristics DIN Power

Number of contacts	3 – 48	Insertion and withdrawal force	
Contact spacing	5.08 mm; 2.54 mm	Type D, E	32-pol. ≤ 40 N 48-pol. ≤ 75 N
Working current (all contacts are loaded)	Type D, E, F, F9, FM, 2F 6 A max. Type H, H 3 15 A max.	Type F, F9, FM, 2F	24-pol. ≤ 37 N 32-pol. ≤ 50 N 45-pol. ≤ 70 N 48-pol. ≤ 75 N
		Type H	≤ 90 N
		Type H 3	≤ 20 N
Test voltage $U_{r.m.s}$	Type D, E, F, F9, FM, 2F ≥ 1.55 KV Type H ≥ 3.1 KV Type H 3 ≥ 2.5 KV	Materials	
		Mouldings	thermoplastic resin, glass-fibre filled, UL 94-V0 Poly Cyclohexylene Terephthalate (PCT), UL 94-V0
		Contacts	NFF classification up to F1/I2 copper alloy
Contact resistance	≤ 15 mΩ Solder and Wire wrap connection ≤ 20 mΩ Crimp connection	Contact surface	
Insulation resistance	≥ 10 ¹² Ω	Contact zone	selectively plated according to performance level hard silver plated or gold plated
Temperature range	-40 °C ... +105 °C Press-in connector -55 °C ... +125 °C max. + 240 °C for 15 s during reflow soldering (only SMC)		



For detailed information see catalogue DIN 41 612 or www.HARTING.com



DIN 41 612

	Shell housings											Open hood			Junction element O	Locking lever O
	A	B	C	2C	3C	D15	D20	D20 metallized	D20 metal	A for 2F	2F	G				
Number of cable entries	2	4	4	3	3	2	4	4	4	1	2	4	2	2		
for screw fixing	X	X	X	X	X	X	X	X	X	X	X	X	X			
for fixing with locking lever	X	X	X	X	X	X								X		
for straight pcb connector			X	X	X											
for front side of the rack	X	X	X	X	X	X	X	X	X	X	X	X	X	X		
for pin shrouds			X	X												
for Interface connector I or U	X	X	X			X				X	X	X	X			
EMC								X	X							
IP20	X	X	X	X	X	X	X	X	X	X	X	X	X	X		
Coding included in shell housing							X	X	X							
for types	B / Q			X												
	2C / 2R				X											
	3C / 3R					X										
	C / R			X												
	<i>harbus 64</i>			X												
	D			X												
	E			X								X				
	F	X	X				X	X	X	X			X	X	X	
	2F									X	X					
H		X				X	X	X	X			X	X	X		
MH		X				X	X	X	X			X	X	X		

Pin shrouds	for types						
	C	2C	R	2R	<i>harbus 64</i>	E	F
screw fixing	X	X	X	X			X
press-in fixing	X	X	X	X	X	X	X

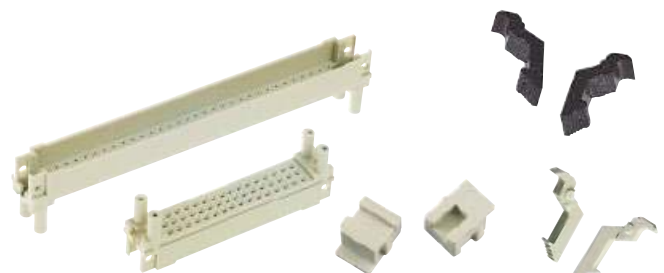

Snap-in clips

In the soldering process, all component terminations including the snap-in clips are soldered and therefore mechanically secured. This provides mechanical protection for the soldered contacts during mating and unmating of the connector.

Mouldings with snap-in clips offer the following advantages:

- Cost reduction when compared with the screw or rivet assembly methods due to the soldering of the clip along with other components in one process.

- The orientation of the clip after soldering in the plated through hole provides mechanical protection against the tensile forces arising from the mating and unmating of the connector.

It is possible to supply the majority of male and female connectors with solder termination with snap-in clips.

For pcb thickness
 $1.6 \pm 0.2 \text{ mm}$
 $\varnothing = 2.8^{+0.1} \text{ mm}$

For pcb thickness
 $1.6 - 4.0 \text{ mm}$
 $\varnothing = 2.8^{+0.1} \text{ mm}$



Mounting force
 40 - 60 N

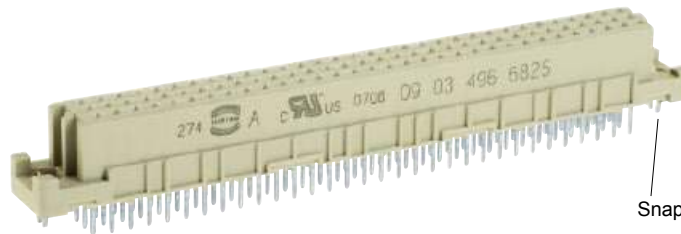

Snap-in clip

Kinked pins

Before and during soldering, the connectors are fixed onto the pcb with four kinked contacts located in the rows a and c, e.g. the positions a1, c1, a32 and c32 for a fully loaded connector.

Connectors with kinked pins are a reliable alternative for female connectors with straight terminations because no additional elements like screws, rivets or clips are necessary.

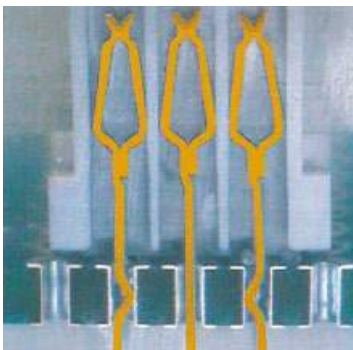
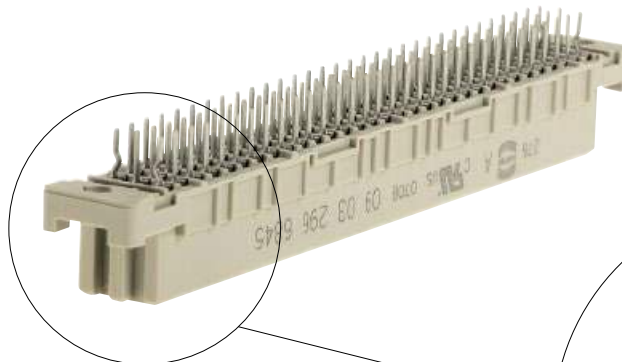
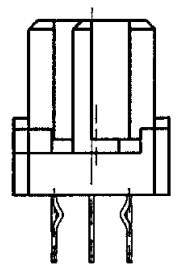

Cross section of a connector with kinked contacts assembled to a pcb

10. Mini Coax Connectors

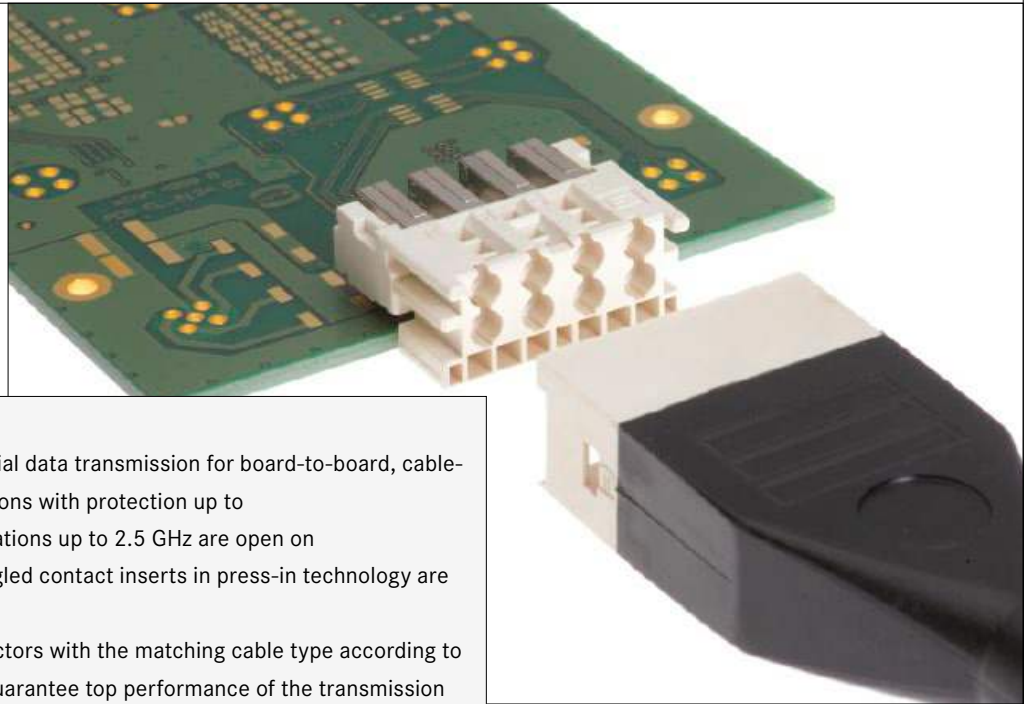

The Mini Coax allows multi-pole coaxial data transmission for board-to-board, cable-to-board and cable-to-cable applications with protection up to IP65 / IP67. At the same time, applications up to 2.5 GHz are open on the basis of 50 Ohm. Straight and angled contact inserts in press-in technology are available for device integration.

HARTING assembles Mini Coax connectors with the matching cable type according to customer specifications in order to guarantee top performance of the transmission lines. A special feature is the connector overmolding, which guarantees a top quality and robust connection between the cable and connector.

Application profile:

CONNECTION TYPE		ENVIRONMENT		APPLICATION						
Board to Board	Cable/Wire to Board	IP20	IP65 / IP67	Data	Signal	Power	high performance			
							Data transfer rate	Shielding	Number of contacts, contact density	Voltage, working current
Cable termination			PCB termination			Application standard				
<i>Han-Quick Lock®</i>	<i>IDC</i>	<i>Crimp</i>	<i>THT</i>	<i>SMC</i>	<i>SMT</i>					
<i>Screw</i>	<i>Cage clamp</i>	<i>Axial screw</i>	<i>Press-in</i>					Housing integration		
								<i>Separate housing</i>	<i>Integrated housing</i>	

Contents

	Page
Mini Coax connector system – introduction	10.02
Mini Coax connector system – general information	10.04
Technical characteristics	10.06
Straight Mini Coax Standard modules for backplane assembly	10.08
Angled Mini Coax Standard modules for daughtercard assembly	10.09
Angled Mini Coax single-row modules for daughtercard assembly	10.10
Mini Coax cable assemblies – general information	10.11
Assemblies with standard modules	10.12
Assemblies with single-row modules and with heavy duty hoods/housings	10.14
Accessories	10.15

MULTI-COAXIAL CONNECTOR SYSTEM MINI COAX

The HARTING multi line Mini Coax connector system for board-to-backplane RF interconnection includes connectors for press-in technology with 1 to 10 coaxial lines.

The Mini Coax connector range allows transmission of analogue signals in various applications like cellular base transceiver stations (BTS), repeaters and passenger entertainment systems at radio frequencies up to 2.5 GHz per line at 50 Ohm.

Moreover, these compact and rugged connectors provide a 6 Sigma mating reliability thanks to the closed-entry contact design. The compact size of Mini Coax modules (minimum pitch of RF lines is 4.4 mm), combined with excellent RF-performance,

makes this connector system especially suitable for high-end equipment.

The twin modules are available in metric sizes of 1.00, 1.25 and 1.50 SU (SU = System Unit = 25 mm) for both cable assemblies and PCBs with 2 to 10 coaxial lines, as well as a single row version with 1 to 3 coaxial lines.

HARTING offers customised cable assemblies including adaptor cables to the most popular discrete coaxial contacts such as SMA, SMB, BNC, N-Type, etc. A complete range of accessories and tools supports the wide product range.

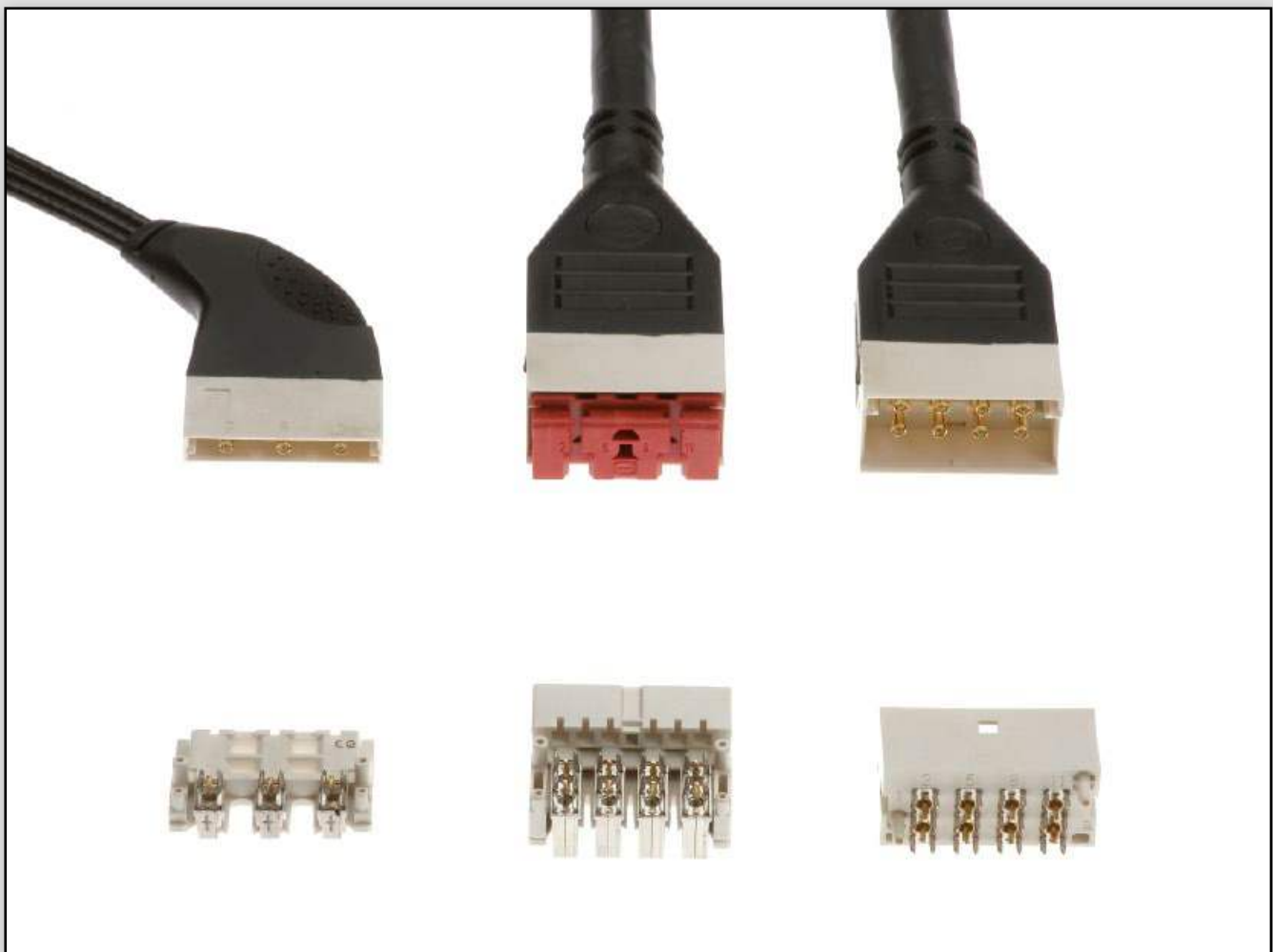

CAN BE USED IN MIXED CONFIGURATION

As board-to-board connectors Mini Coax and *har-bus*[®] HM connectors can be used on board in any mixed configuration.

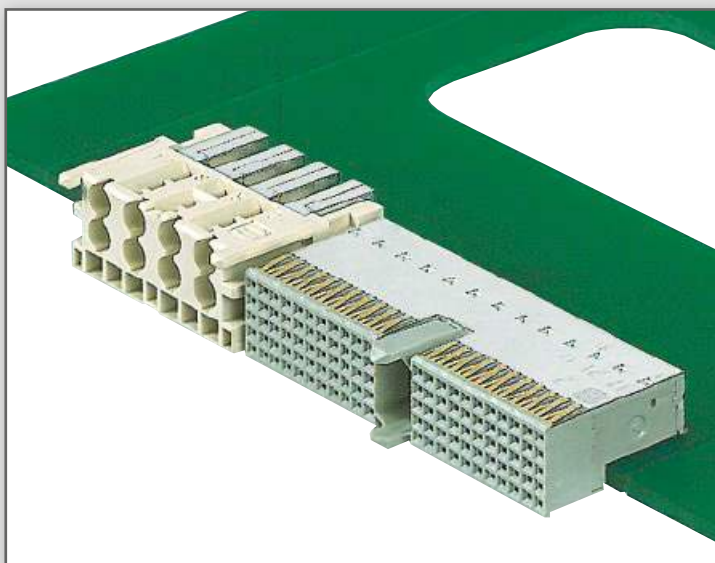

HIGH DATA TRANSMISSION RATE

The press-in termination offers an easy processing with very high frequency rates up to 2.5 GHz (even 4.5 GHz with the single row connector).

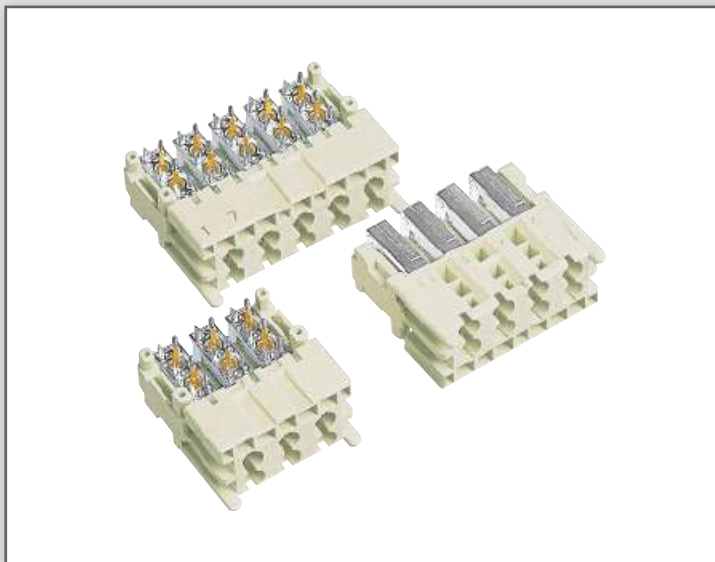

IP65 ENVIRONMENT

The combination of a Mini Coax connector with a Han[®] housing results in a proper IP65 Industrial Mini Coax connector.

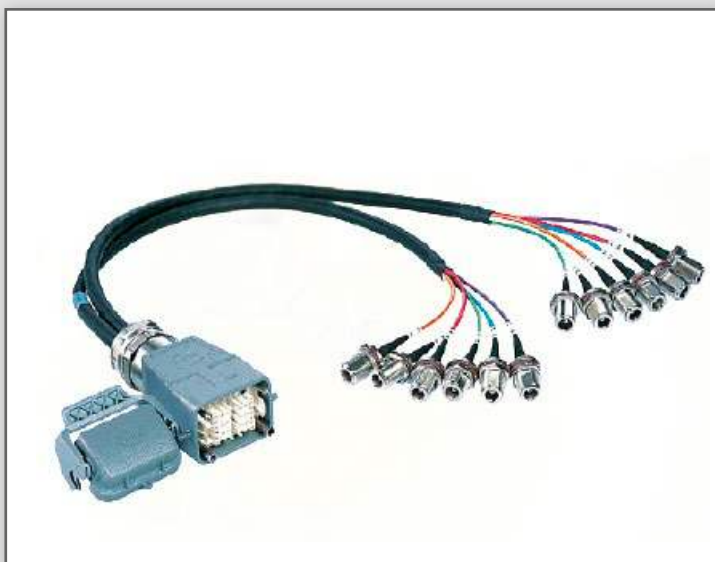

The Mini Coax connector is a multi line RF connector for blind mating of board-to-board, board-to-cable or cable-to-cable applications. The Mini Coax connector is mainly used in both RF (Radio Frequency) and IF (Intermediate Frequency) signal transmission and is specified for a frequency range from DC to 2.5 GHz and beyond. Thanks to its compact size (a 10 coaxial contacts' connector is as small as a PC's enter key) and excellent crosstalk features, this connector system is ideal for high end equipment within cellular telecom infrastructure.

The isolated coaxial lines are implemented in a plastic housing that defines the module size in a metric scale from 1.00, 1.25 and 1.50 SU

(SU = System Unit = 25 mm). The Mini Coax connectors are available as straight sockets and right angled plugs. Both types are executed in press-in technology for the PCB (Printed Circuit Board) termination. The straight modules are delivered with an inserted plastic cap that protects the coaxial contacts against dust and dirt, as well as being used as an upper press-in tool. In this way, an easy and safe flat rock process is guaranteed.

The contacts of the Mini Coax single-row connector are single line, as opposed to the standard connector. This delivers enhanced performance, especially in terms of isolation, and is also suitable for slim cabinet applications.

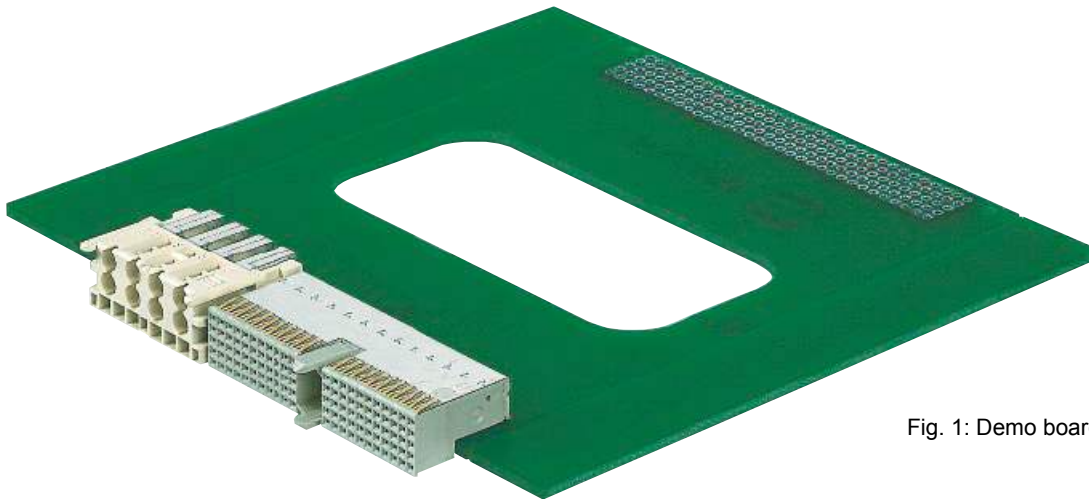

Fig. 1: Demo board

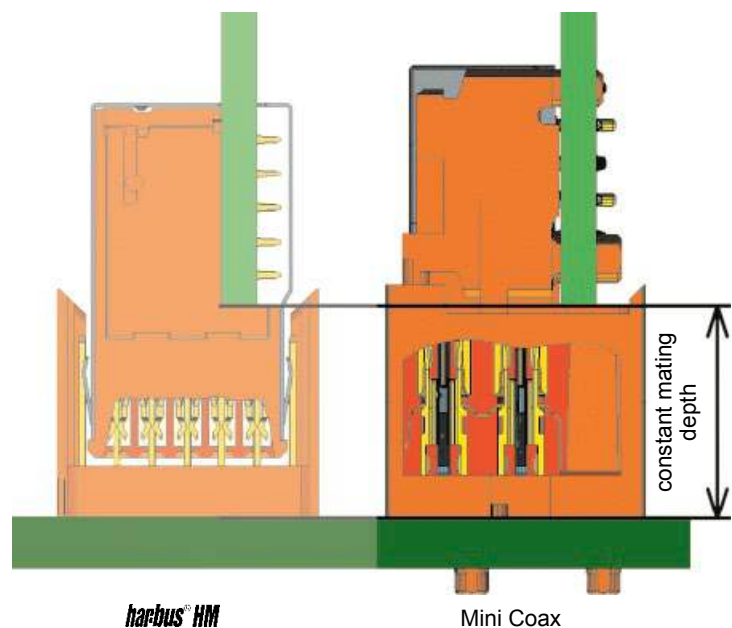

Fig. 2: Cross section of both connector types

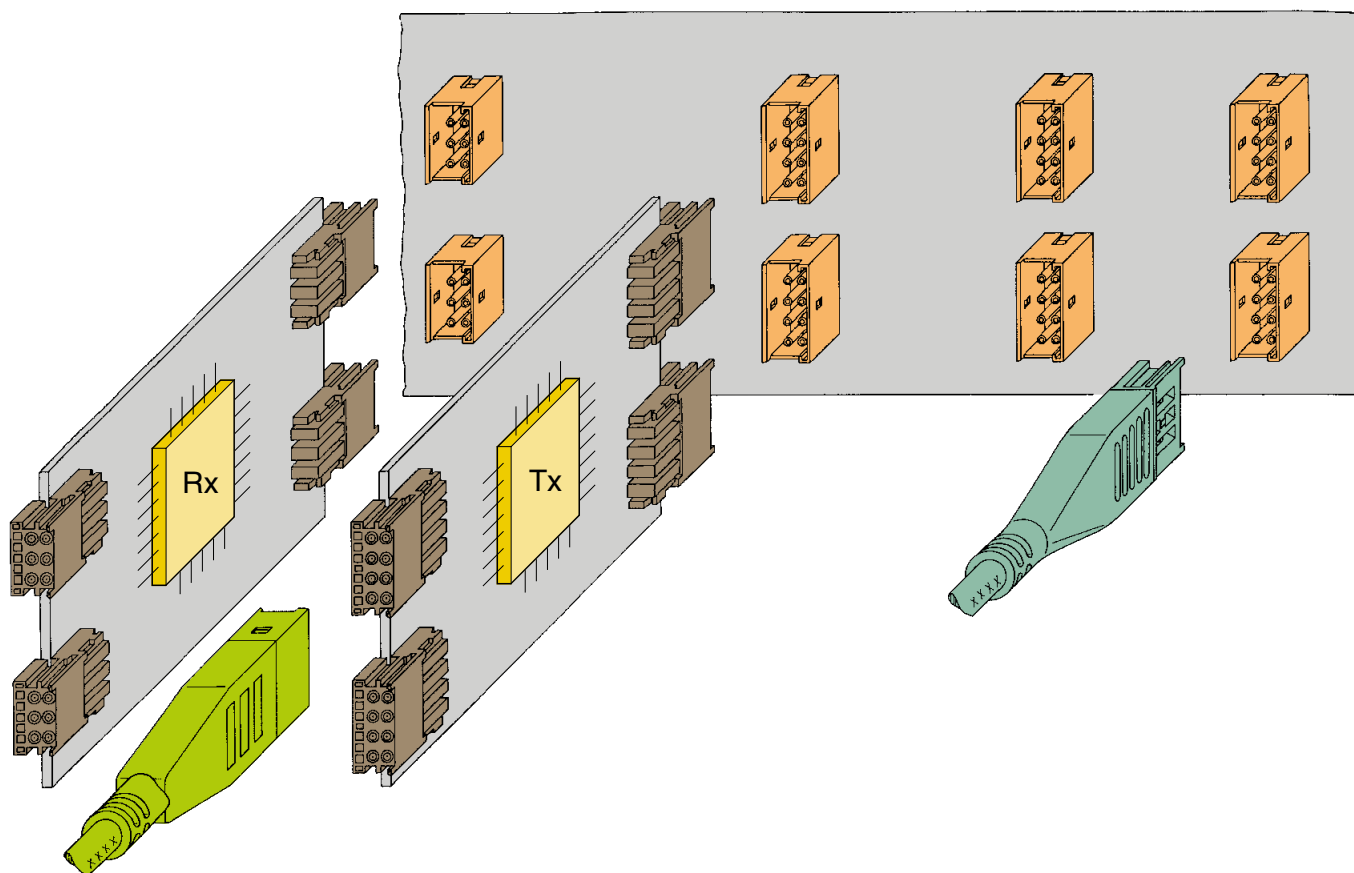

Fig. 3: Typical pcb configurations

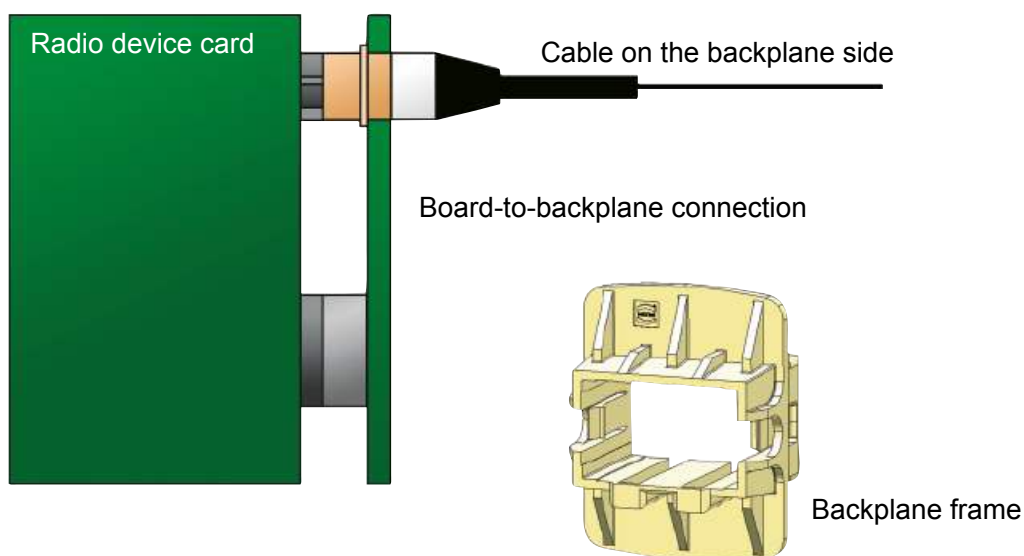

Fig. 4: Mini Coax backplane feed through

Number of contacts : 1, 2, 4, 6, 8 or 10 coaxial contacts
 Grid pattern : 4.40 x 6.25 mm (within a twin x between twins);
 8.80 mm for Mini Coax single-row connectors

Dielectric withstanding Voltage $U_{r.m.s.}$: ≤ 1000 V (for 60 s)
 DC-contact resistance
 Centre contact : ≤ 12 m Ω
 Ground contact : ≤ 6 m Ω
 Insulation resistance : ≥ 5000 M Ω

Power : ≤ 40 W (at 2.5 GHz)
 Frequency range : DC ... 2.5 GHz
 Nominal impedance : 50 Ω
 Return loss : < -20 dB
 VSWR : < 1.22
 Insertion loss : < 0.25 dB

Near end crosstalk (NEXT) :

Pin distance	Board-to-Board	Board-to-Cable	Cable-to-Cable
$\Delta x = 4.40$ mm	50 dB	60 dB	90 dB
$\Delta x = 6.25$ mm	60 dB	70 dB	90 dB
$\Delta x = 7.64$ mm	75 dB	80 dB	90 dB
$\Delta x = 8.80$ mm	–	75 dB	–
$\Delta x = 12.50$ mm	90 dB	90 dB	90 dB

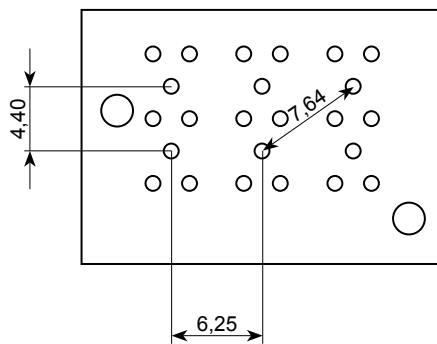

Fig. 5: Grid pattern
Mini Coax Standard

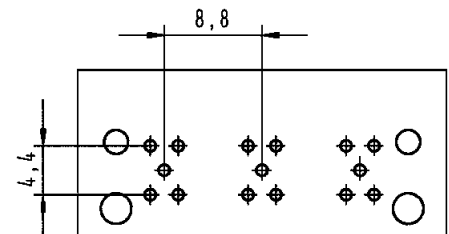

Fig. 6: Grid pattern
Mini Coax single-row

Temperature range : -55 °C ... $+125$ °C

Moulding material : Liquid Cristal Polymer (LCP), UL 94-V0

Contact surface : Au
 Contact zone : Au
 Termination area : Au
 Centre pin : Au
 Ground pin : Ni

Mating cycles : max. 500

Recommended configuration of plated through holes :

<i>Tin plated PCB (HAL) acc. EN 60352-5</i>	Hole-Ø	1.15 ^{±0.025} mm
	Cu	min. 25 µm
	Sn	max. 15 µm
	Plated hole-Ø	0.94-1.09 mm
<i>Chemical tin plated PCB</i>	Hole-Ø	1.15 ^{±0.025} mm
	Cu	min. 25 µm
	Sn	min. 0.8 µm
	Plated hole-Ø	1.00-1.10 mm
<i>Au / Ni plated PCB</i>	Hole-Ø	1.15 ^{±0.025} mm
	Cu	min. 25 µm
	Ni	3-7 µm
	Au	0.05-0.12 µm
	Plated hole-Ø	1.00-1.10 mm
<i>Silver plated PCB</i>	Hole-Ø	1.15 ^{±0.025} mm
	Cu	min. 25 µm
	Ag	0.1-0.3 µm
	Plated hole-Ø	1.00-1.10 mm
<i>OSP copper plated PCB</i>	Hole-Ø	1.15 ^{±0.025} mm
	Cu	min. 25 µm
	Plated hole-Ø	1.00-1.10 mm

PCB board thickness: ≥ 1.6 mm

Mating force : ≤ 10 N/contact

Withdrawal force : > 1 N/contact

Mating distance : 12.5 ... 15 mm

Wiping length : 2.5 mm

Acceptable radial mating offset : max. ± 1.5 mm

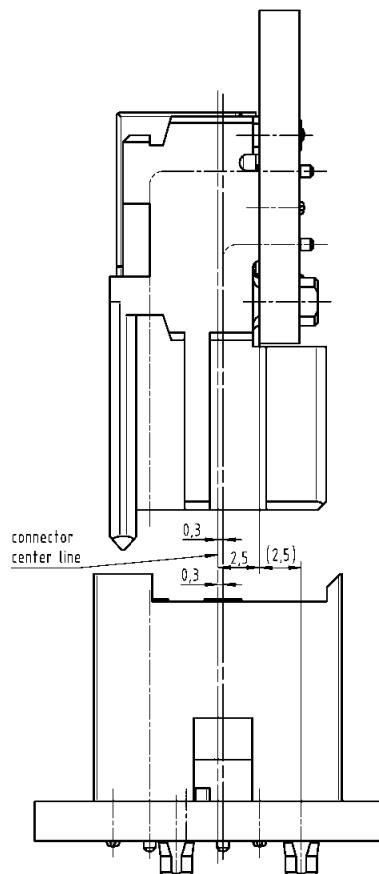

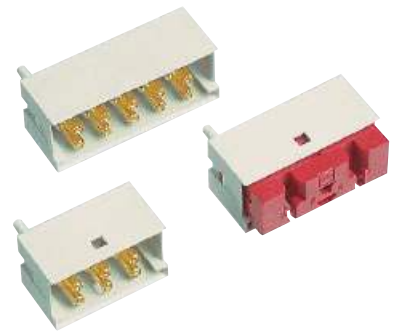

Straight modules

Identification	Number of contacts	SU	loaded positions	Part number
Mini Coax modules, press-in termination	10	1.50	2, 5, 8, 11, 14	07 11 100 0026
	8	1.25	2, 5, 8, 11	07 11 100 0024
	6	1	2, 5, 8	07 11 100 0023
	4	1	2, 8	07 11 900 0024
	2	1	2	07 11 900 0023

Dimensions

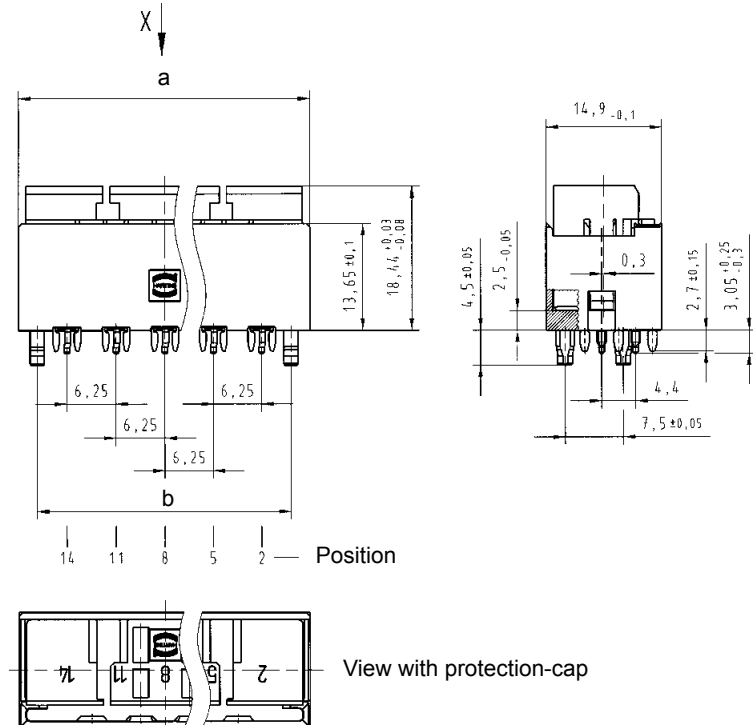

Straight module	Dimension [mm]		
	a	b	c
1.50 SU	37.3	32.5	25
1.25 SU	31.05	26.25	18.75
1.00 SU	24.8	20	12.5

Board drillings

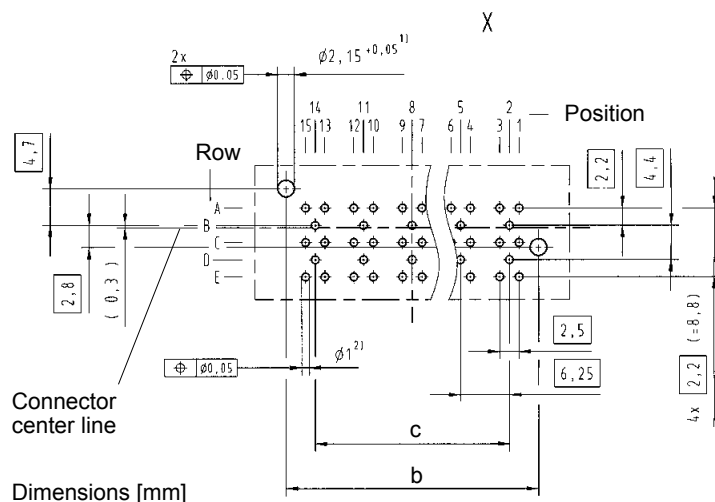

Row B, D: position 2, 5, 8, 11, 14 for signal line
 Row A, C, E: position 1, 3, 4, 6, 7, 9, 10, 12, 13, 15 for ground-line

1) Non-metallised drillings

2) Details see page 10.07

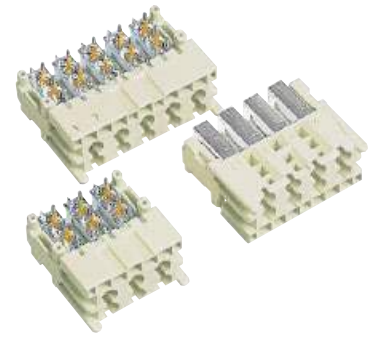

Angled modules

Identification	Number of contacts	SU	loaded positions	Part number
Mini Coax modules, press-in termination	10	1.50	2, 5, 8, 11, 14	07 31 100 0021
	8	1.25	2, 5, 8, 11	07 31 100 0020
	6	1	2, 5, 8	07 31 100 0019
	4	1	2, 8	07 31 900 0022
	2	1	2	07 31 900 0021

Dimensions

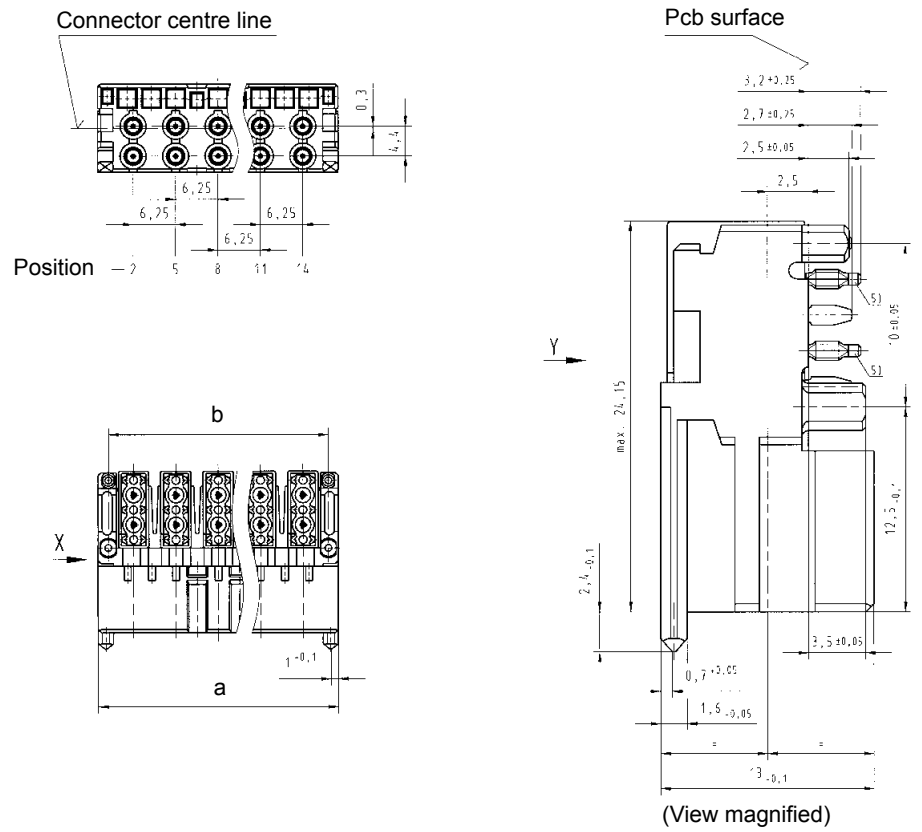

Board drillings

Angled module	Dimension [mm]		
	a	b	c
1.50 SU	35.45	32.5	25
1.25 SU	29.15	26.25	18.75
1.00 SU	22.9	20	12.5

Row B, D: position 2, 5, 8, 11, 14 for signal line
 Row A, C, E: position 1, 3, 4, 6, 7, 9, 10, 12, 13, 15 for ground-line

- 1) Non-metallised drillings
- 2) No tracks, except solder eyes
- 3) Limit area of components (valid for both pcb-sides)
- 4) Details see page 10.07
- 5) Press-in zone in any angular position related to it's longitudinal axis possible

Dimensions [mm]

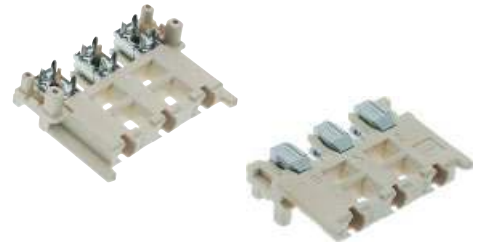

Angled modules

Identification	Number of contacts	SU	loaded positions	Part number
Mini Coax single-row module, press-in termination	3	1	2, 5, 8	07 31 100 0028

Dimensions

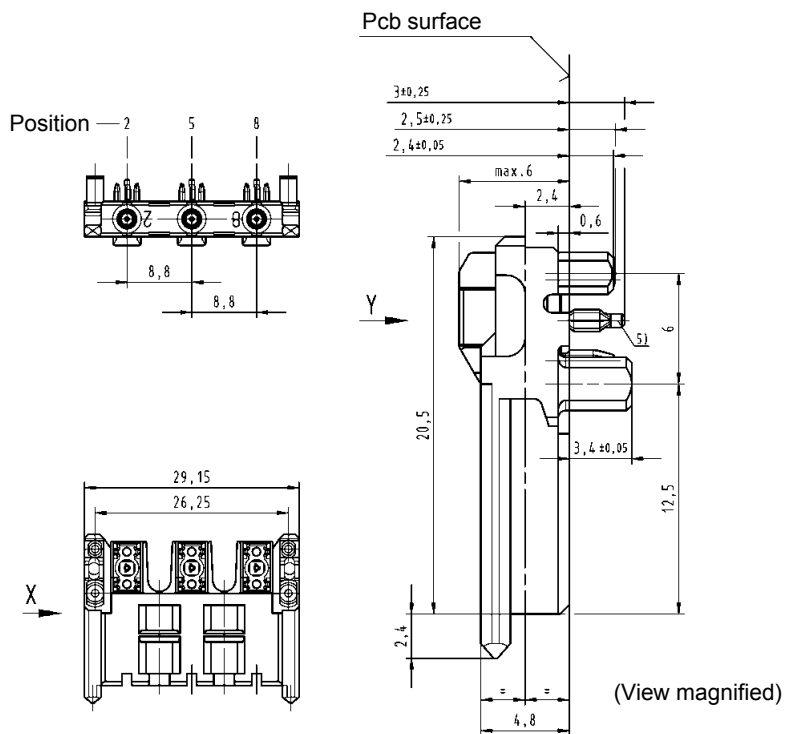

Board drillings

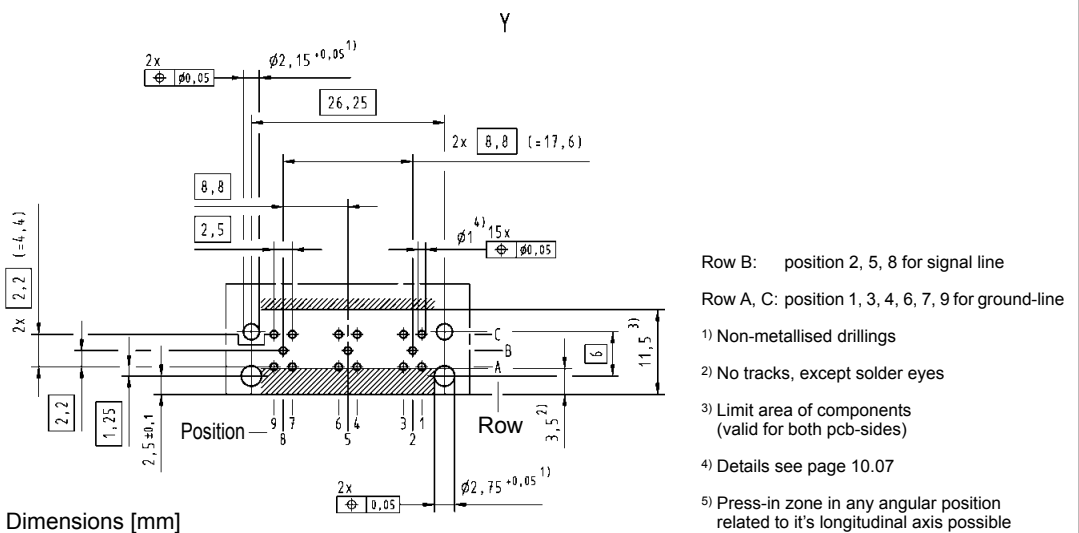



The Mini Coax product range also includes various cable assemblies and accessories, which provide customers with flexible application options.

The Mini Coax cable connector is available as plug and socket and is crimped to a coaxial cable that can be individually assembled with RF-cable connectors (SMA, SMB, N-type ...). While delivering high RF transmission performance, the moulded Mini Coax cable assemblies provide robust connections. The various angle mould types meet different cable routing requirements according to the available space. Thanks to various accessories, such as backplane frame, Han® housing insert and press-in cable housing ..., customized connecting requirements can be met.

Remark:

The cable assemblies and accessories shown are part of the overall product range.

Additional, customized parts are available on request.



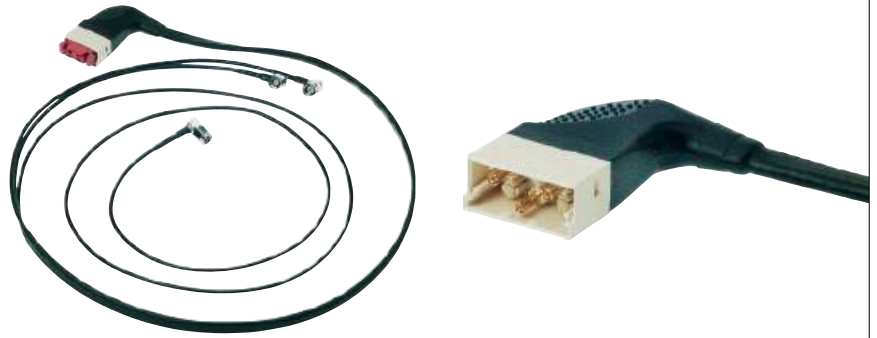

Cable assemblies

Identification	Number of contacts	Part number	Drawing	Dimensions in mm
----------------	--------------------	-------------	---------	------------------

Cable assembly for mating with the angled standard module

1-10

on request

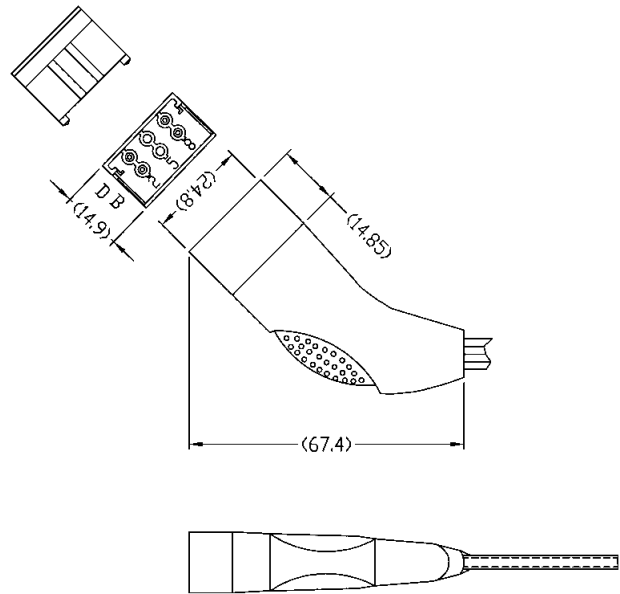



Cable assemblies

Identification	Part number	Drawing	Dimensions in mm
<p>Cable assembly Mini Coax, 6 position female connector (straight) to SMA crimp connector</p> <p>Hood: overmoulded with top entry</p> <p>Wiring: 1:1</p> <p>Length: L = 0.5 m L = 1.5 m L = 2.0 m</p>	<p>33 07 233 0500 109 33 07 233 1500 110 33 07 233 2000 111</p>		
<p>Cable assembly Mini Coax, 6 pole, male</p> <p>Cable: Mini Coax cable</p> <p>Hood: overmoulded with top entry</p> <p>Wiring: 1:1</p> <p>Length: L = 0.5 m L = 1.5 m L = 2.0 m</p>	<p>33 07 223 0500 112 33 07 223 1500 113 33 07 223 2000 114</p>		



Assemblies with single-row modules and hoods/housings

Identification	Number of contacts	Part number	Drawing	Dimensions in mm
Cable assembly for mating with the angled single-row module	1-3	on request		
Cable assembly with heavy duty hoods/housings	1-10	on request		

Mini Coax



Accessories

Identification

Part number

Test adapter
SMA – Mini Coax
male for straight modules
female for angled modules

07 73 000 0394
07 73 000 0393

General information

The Mini Coax-to-SMA Adapter can be directly connected to measurement instrument cables. This allows the precise RF transmission characterization of module cards, backplanes and cable assemblies.

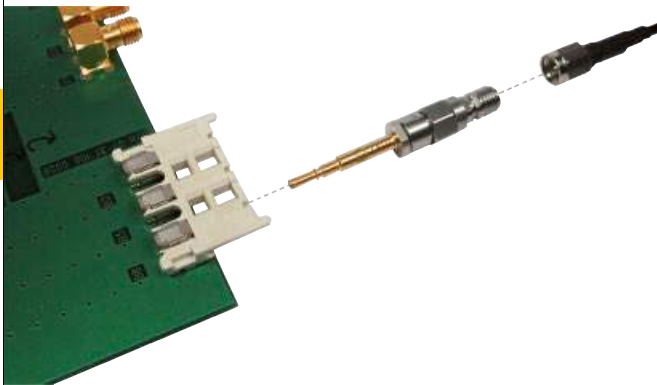

Features:

- SMA connector directly attached to the Mini Coax
- Impedance deviations between adapters < 1.5 Ω
- Good reproducibility of test results
- Test results between different labs are comparable
- Precise measurements of Mini Coax connector system

Electrical characteristics

Mini Coax test adapter	Impedance values @ 31.5 ps rise time at reference plane (10% - 90%):		Max. impedance deviation [Ω]
	Max. [Ω]	Min. [Ω]	
SMA to male	52.5	47.5	1.5
SMA to female	53.5	48.0 40.5*	1.0

Connector	Electrical length [ps]
Mated SMA to male / female adapter	262.2

Frequency [GHz]	Return loss [dB] mated adapter pairs	Insertion loss [dB] mated adapter pairs
< 1	- 26.9	- 0.17
< 2	- 22.5	- 0.24
< 3	- 19.9	- 0.26
< 4	- 16.4	- 0.34
< 5	- 14.4	- 0.42

*: Impedance drop is due to the female Mini Coax connector design.

Dimensions [mm]

Male test adapter

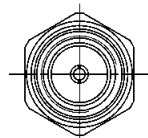
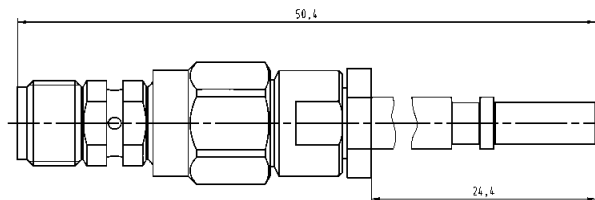
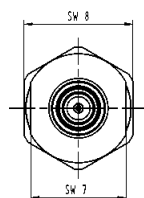

Female test adapter

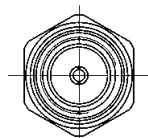
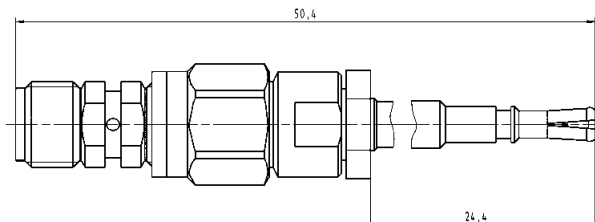
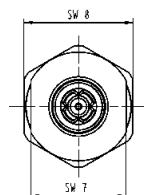

11. har-bus® HM Connectors

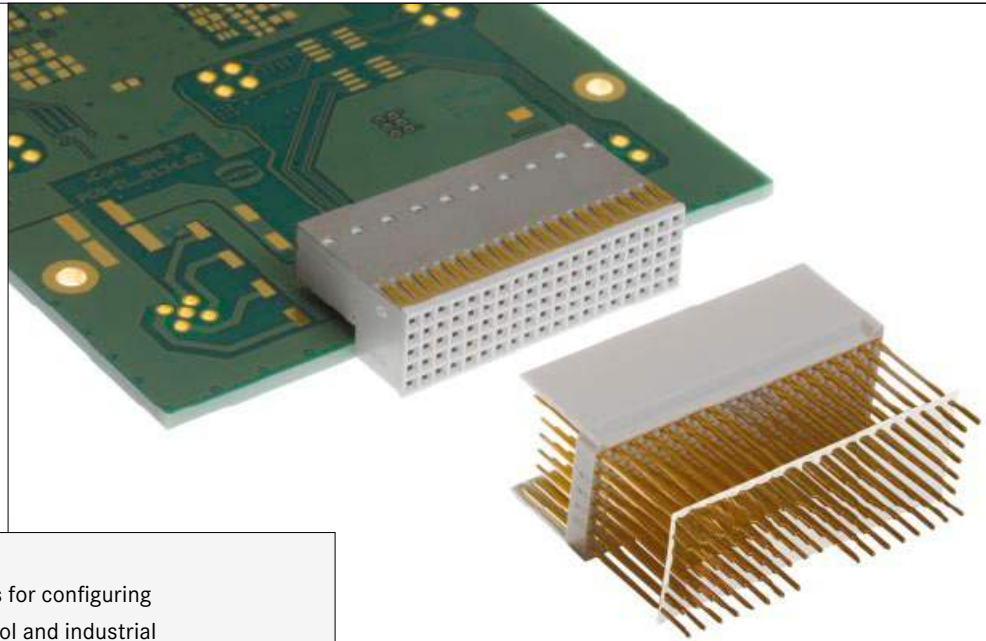

har-bus® HM connectors are the basis for configuring high-performing backplanes for control and industrial computer systems in 19" technology. These connectors are standardized for the CompactPCI and the VME64x bus. All connectors are designed for press-in technology, the female connectors are also available as a solder version.

Application profile:

CONNECTION TYPE		ENVIRONMENT		APPLICATION						
Board to Board	Cable/Wire to Board	IP20	IP65 / IP67	Data	Signal	Power	high performance			
				Data transfer rate	Shielding	Number of contacts, contact density	Voltage, working current			
Cable termination			PCB termination			Application standard				
Han-Quick Lock®	IDC	Crimp	THT	SMC	SMT	VMEbus Technology CompactPCI				
Screw	Cage clamp	Axial screw	Press-in	Housing integration						
				Separate housing	Integrated housing					

Contents

Page

harbus® HM Standard

Introduction	11.02
General information and technical characteristics	11.04
Types A, B, AB, C with 5 + 2 rows	
Straight male connectors	11.12
Angled female connectors	11.24
Type Monoblock 47	
Straight male connectors	11.28
Angled female connectors	11.30
Types D, E, DE with 8 + 2 rows – Straight male connectors	11.32

harbus® HM Power

General information	11.36
Angled male connectors	11.38
Straight female connectors	11.40

Accessories

Coding keys	11.41
Shrouds	11.42
Guiding system	11.47
Customer request form	11.48

Any possible contact configuration can be requested with the customer request forms (see pages 11.48 ff). Alternatively please contact your local HARTING representative.

HARD METRIC CONNECTORS *har-bus*[®] HM IN 2.00 mm PITCH

har-bus[®] HM connectors are the basis for configuring high-performing backplanes for control and industrial computer systems in 19" technology.

HARTING offers 5 row and 8 row 2 mm hard metric connectors *har-bus*[®] HM according to IEC 61 076-4-101. The product family includes all standard types such as all variants for CompactPCI, inclusive Hot Swap and CTI (Computer Telephony Integration). The modules are defined as the 5+2 row types A, B, AB and C and the 8+2 row types D, E and DE. All male and female connectors are available with press-in terminations.

The high current *har-bus*[®] HM Power connector complies with the OBSAI specification V1.1. This very compact connector can be loaded with up to four contacts, each contact carrying up to 23 A at 70 °C (in OBSAI configuration). The connector is offered in four lengths to allow hot swapping. The right-angled male connectors are available for press-in and for PiHIR soldering.

Accessories and press-in tooling are available for all connectors.

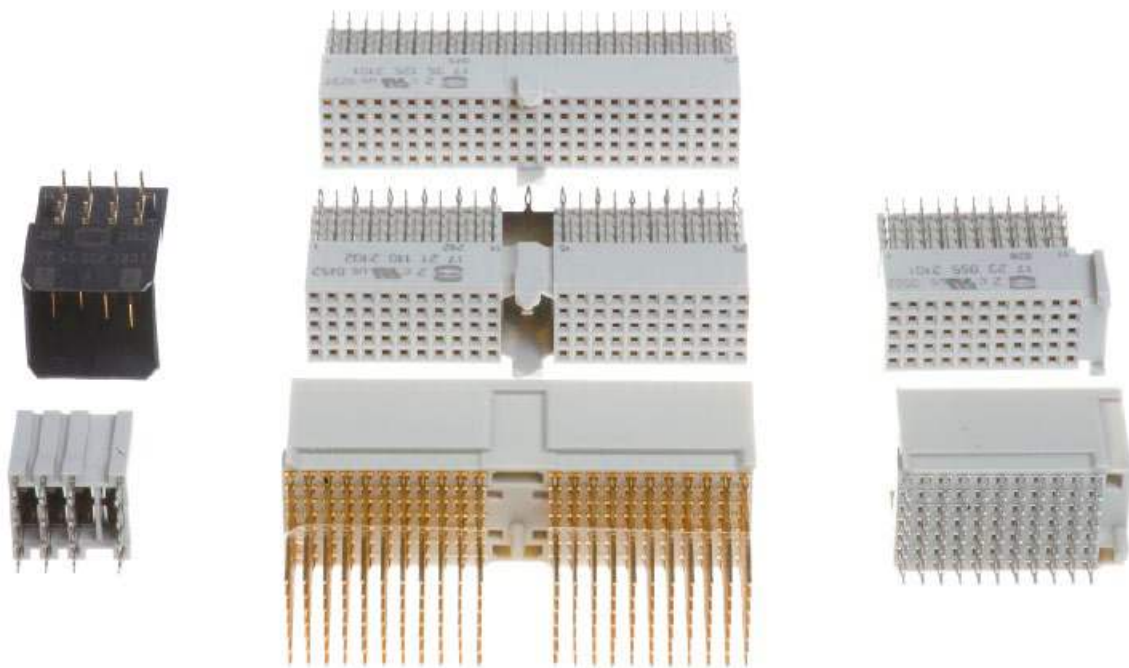

COMBINED STYLE FOR CompactPCI:

Additional to the standard insulator types according to the specification there is a Monoblock available, especially for CompactPCI applications. It unites the type A and the type B₂₂ in one connector. With the Monoblock, only one connector is necessary for a standard configuration of a 3U module card which offers a cost advantage in the production process and logistics.

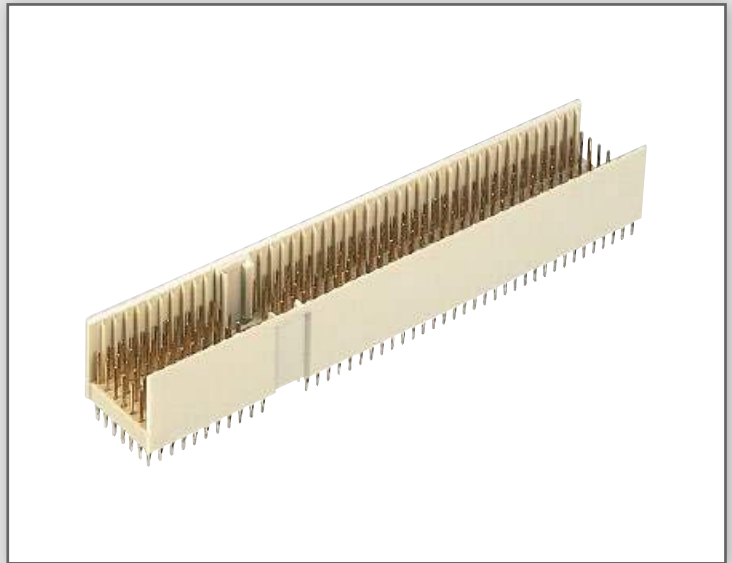

“NEEDLE-EYE” PRESS-IN TECHNOLOGY:

The *har-bus*[®] HM press-in zone is based on the industry renowned needle-eye technology. Its special design allows for compensation of tolerances of pcb surface properties (e.g. superfluous tin plating). The excessive material is displaced within the plated through hole, whereby a gas-tight and corrosion resistant electrical connection is assured.

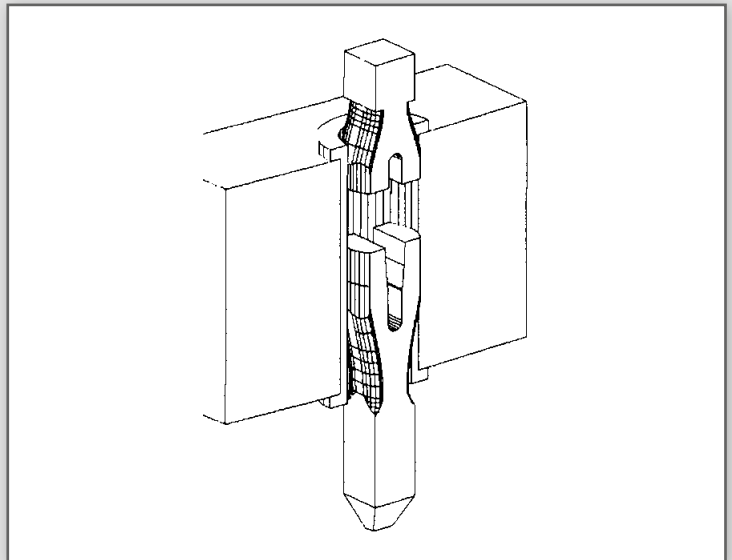

INTERNATIONAL STANDARD:

The *har-bus*[®] HM connectors are designed to meet the PICMG 2.x specification and can be used in CompactPCI. CompactPCI is a common standard e.g. for industrial computers.



Design according	: IEC 61 076-4-101
Approvals Underwriters Laboratories Inc.®	:  us with their respective ratings documented in file E 102079
Number of contacts	: 55 – 220 signal (77 – 308 fully shielded); or customised
Contact spacing	: 2.00 mm
Working current	: 1 A @ 70 °C (80 % derating)
Test voltage $U_{r.m.s.}$: AC 750 V min.
Contact resistance	: 20 mΩ max.
Insulation resistance	: 10 GΩ min.
Temperature range	: -55 °C ... +125 °C
Durability as per IEC 61 076-4-101	: Performance level 2 = 250 mating cycles in total. <i>First 125 mating cycles, then 4 days gas test using 0.5 ppm SO₂ and 0.1 ppm H₂S (at 25 ± 2 °C and 75 ± 3 % humidity). Measurement of contact resistance.</i> <i>The remaining 125 mating cycles are subject to measurement of contact resistance and visual inspection. No abrasion of the contact finish through to the base material. No functional impairment.</i> Performance level 1 = 500 mating cycles in total. <i>First 250 mating cycles, then 10 days gas test using 0.5 ppm SO₂ and 0.1 ppm H₂S (at 25 ± 2 °C and 75 ± 3 % humidity). Measurement of contact resistance.</i> <i>The remaining 250 mating cycles are subject to measurement of contact resistance and visual inspection. No abrasion of the contact finish through to the base material. No functional impairment.</i>
Termination technique	: compliant press-in
Mating force	: 0.75 N/pin max.
Withdrawal force	: 0.15 N/pin min.
Materials	
Mouldings	: Thermoplastic resin, glass-fibre filled, UL 94-V0
Contacts	: Copper alloy
Contact surface	
Contact zone male	: Au/PdNi/Ni, contacts are treated with Bellcore recommended lubricant (PPE)
Contact zone female	: Au/Ni, contacts are treated with Bellcore recommended lubricant (PPE)
Press-in zone	: Ni
Packaging	: Tube

Due to the high deformation capability and resilience of **harbus[®] HM** press-in contacts, they can be easily and repeatedly removed in case of repairs without impairment to their functioning.

harbus[®] HM press-in contacts are extremely versatile and offer a reliable electrical contact, therefore they are especially well suited for applications with these surfaces.

Please contact us for detailed test reports.

Benefits of press-in technology

- Thermal shocks associated with the soldering process and the risk of the board malfunction are avoided.
- No need for the subsequent cleaning of the assembled pcb's
- Unlimited and efficient processing of partially gold-plated pins for rear I/O - manual soldering is no longer necessary!

Recommended configuration of plated through holes

The press-in zone of the **harbus[®] HM** connectors is approved to be used with a plated through hole according EN 60352-5 with a diameter of 0.60 ± 0.05 mm (drilled hole 0.7 ± 0.02 mm).

Based on our experiences regarding the production process of the PCB manufacturer, we recommend a plated through hole configuration like shown in the below spreadsheet. To achieve the recommended plated through hole diameter, it is important to specify especially the drilled hole diameter of 0.7 ± 0.02 mm to your PCB supplier.

<i>Tin plated PCB (HAL)</i>	Hole-Ø	0.7 ± 0.02 mm
	Cu	min. 25 µm
	Sn	max. 15 µm
	Plated hole-Ø	0.60-0.65 mm
<i>Chemical tin plated PCB</i>	Hole-Ø	0.7 ± 0.02 mm
	Cu	min. 25 µm
	Sn	min. 0.8 µm
	Plated hole-Ø	0.60-0.65 mm
<i>Au / Ni plated PCB</i>	Hole-Ø	0.7 ± 0.02 mm
	Cu	min. 25 µm
	Ni	3-7 µm
	Au	0.05-0.12 µm
	Plated hole-Ø	0.60-0.65 mm
<i>Silver plated PCB</i>	Hole-Ø	0.7 ± 0.02 mm
	Cu	min. 25 µm
	Ag	0.1-0.3 µm
	Plated hole-Ø	0.60-0.65 mm
<i>OSP copper plated PCB</i>	Hole-Ø	0.7 ± 0.02 mm
	Cu	min. 25 µm
	Plated hole-Ø	0.60-0.65 mm

PCB board thickness: ≥ 1.4 mm

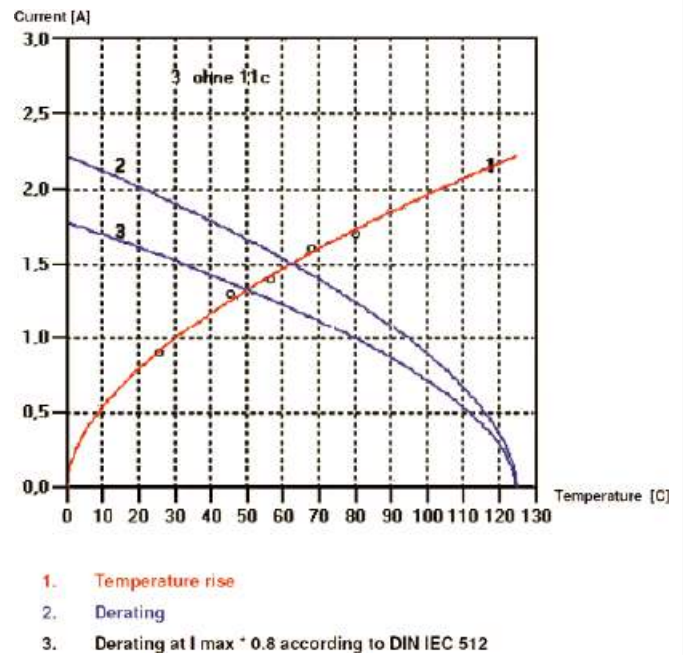

Derating curve

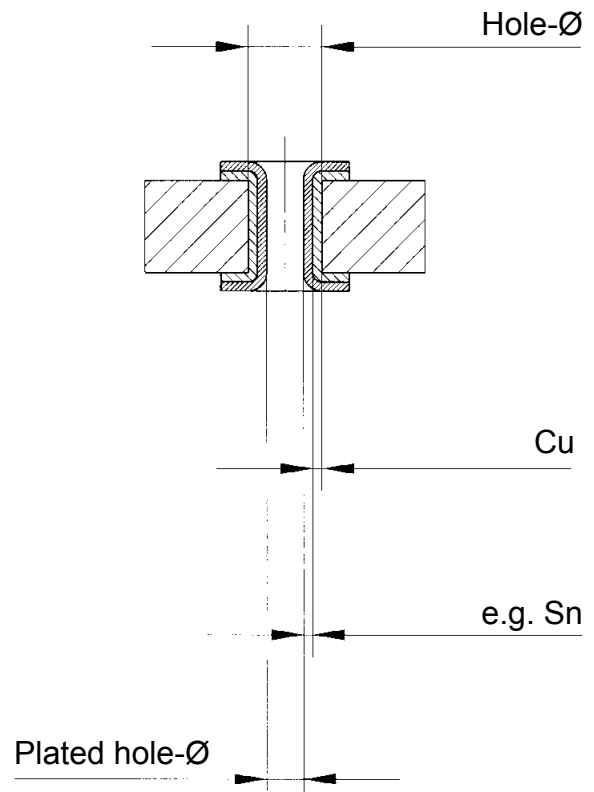

Recommended configuration of plated through holes, valid for **harbus[®] HM**

HARTING offers 13 contact lengths for *harbus[®] HM* male connectors: the standard mating length of 8.2 mm, pre-leading contacts with 9.7 mm and extra long contacts preferred for shielding with 11.2 mm mating length.

On the termination side the standard length is 3.7 mm. With the three termination lengths of 13.0, 14.5 and 16.0 mm even for rear I/O applications different mating levels are possible, depending on the pcb thickness and shroud height.

For the standard termination length, an extra short contact for special applications with a mating length of 7.2 mm is available.

The different contact lengths are designated with letters to identify them in the configurations. For special loadings please use the customer request form at the end of this chapter.

All contacts are offered with press-in termination 'eye of the needle'. In accordance with the application they can be delivered in performance level 1 or 2.

Contact dimensions [mm]

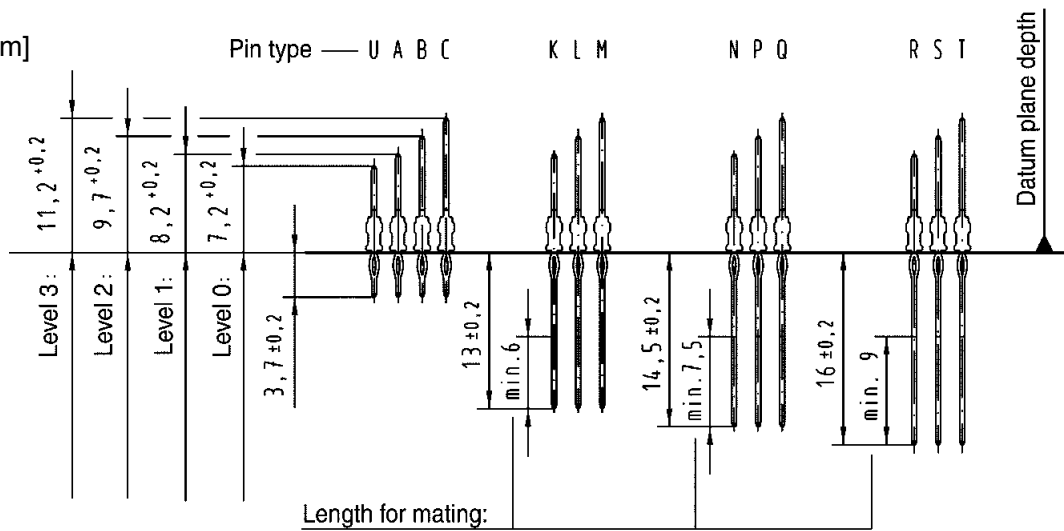

Circuit density

When using the specified diameter of the finished through hole according to IEC 61 076-4-101 (0.6 ± 0.05 mm) with an appropriate annular ring, the remaining distance between the rings is about 1 mm. Under the condition that the width of the track and the space between should be equal, two tracks of 0.2 mm width or three tracks of 0.14 mm width can be placed between two rings. Typical designs are shown in the drawing on the right side.

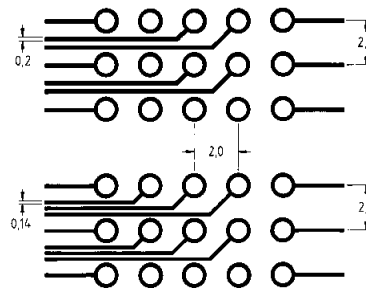

Alignment of male and female connector

For the alignment of male and female connector, a common reference plane is defined. This reference plane is the top side of the daughtercard pcb and the contact rows "b" of the female and the male connector (see drawing).

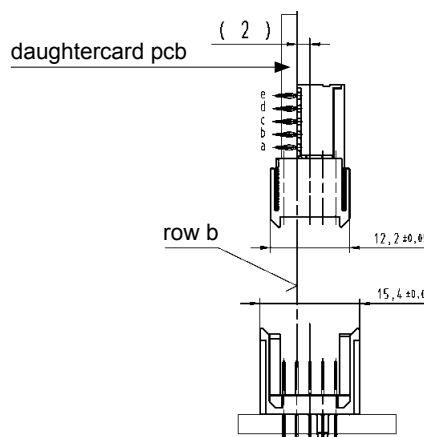

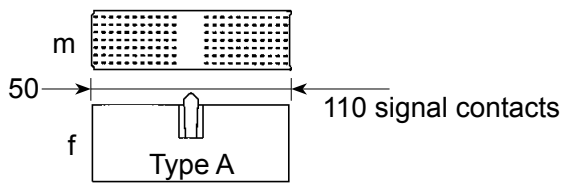

All HARTING *harbus[®] HM* connectors can be assembled end to end in any configuration.

General rules:

- Type B connectors should always be used in combination with an A type and/or C type connectors that are fitted with alignment features.
- Type C connectors must be assembled at the end of a connector stack, to achieve polarisation and avoid mismatching.
- To ensure the correct slot position of connector stacks coding can be added with type A connectors.
- Starting with an type A module (50 mm) any module can be added within the above recommendation (see typical examples shown in the diagram).

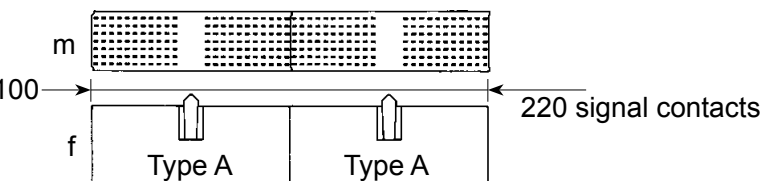
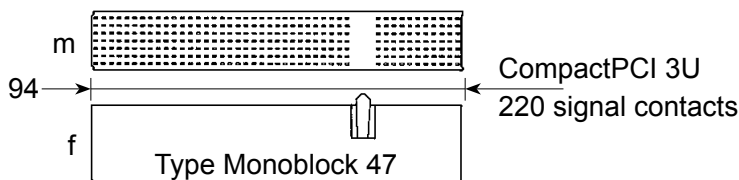
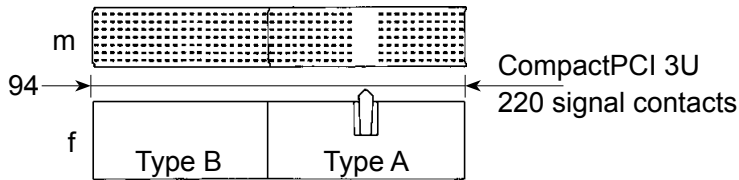

m = male connector
f = female connector

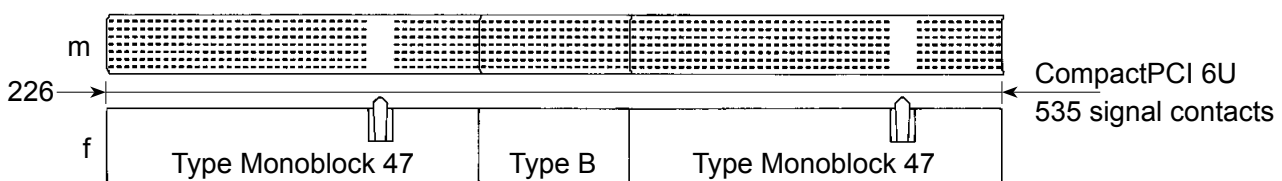
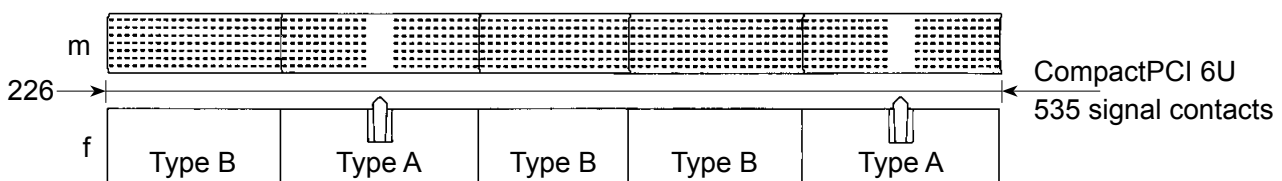
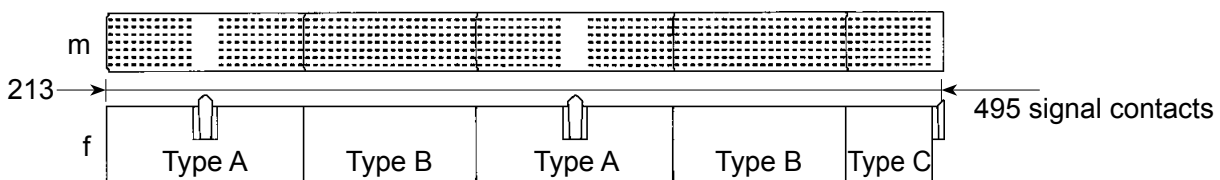

Improved guiding with AB-modules:

In accordance with the equipment practice each front side arrangement of *harbus[®] HM* connectors shall have at least one A-module per slot to ensure that the connector can accommodate ± 2 mm alignment tolerances in rack systems.

On some rear I/O arrangements the A-module's alignment capability cannot be utilised, because only B-modules are used for feed through. Consequently AB-modules were introduced to ensure guiding capabilities where formerly only B-modules were used. Those AB-modules represent a combination of A- and B-modules and are specified in **CompactPCI by PICMG 2.0 Rev. 3.0** for certain rear I/O applications.

The AB-modules have guiding pegs similar (but not mating compatible to prevent mismating) to those

of the A-module providing the same proven mating tolerances of ± 2 mm. The AB-modules have no coding center but are fully equipped with contacts in order to maintain the full density as per the B-modules.

The **AB-female** connector mates either with an **AB-shroud** or with **AB-male** connectors. The centered pin positions of the shielding rows of male connectors are simply equipped with short spill contacts (if standard connector and shroud are used). This prevents that the guiding peg of the female AB-module stubbing on the feed through contacts of the front side's fixed connector. These fixed connector loadings are called **AB-friendly**.

The AB-male connector will not be equipped with shielded contacts in the centre where the guiding peg will engage.

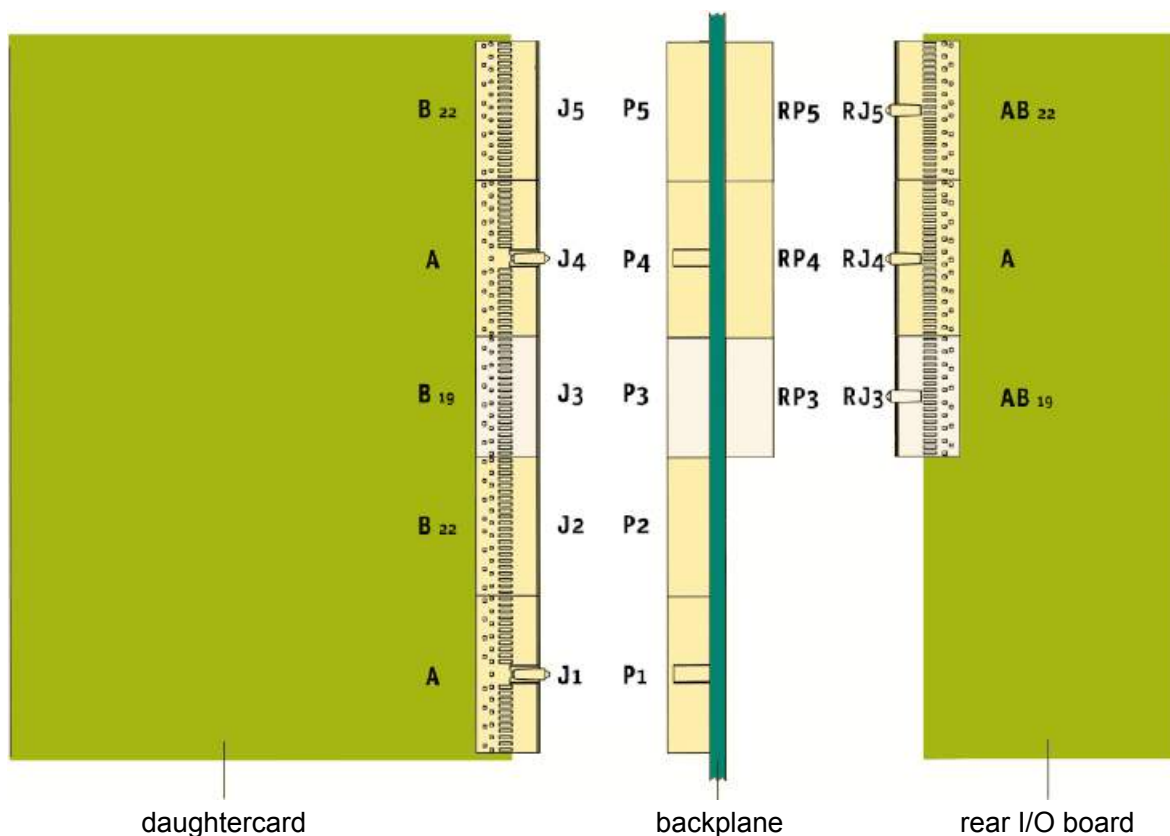
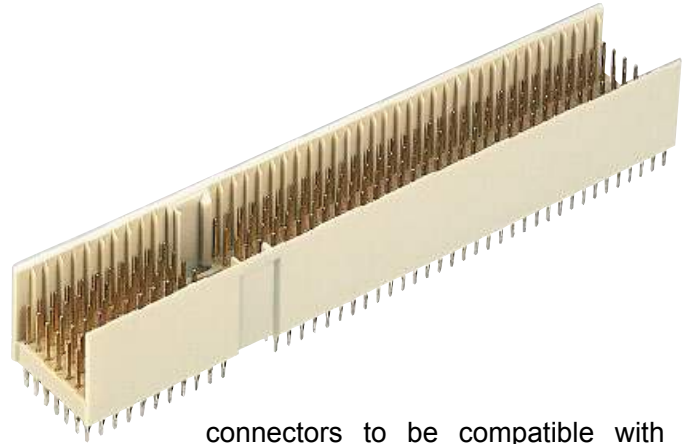

Fig. 3: CompactPCI 6U configuration

CompactPCI[®] as a standard is maintained and enhanced by the PCI Industrial Computer Manufacturers Group (PICMG[®]). It defines a combination of the electrical and logical specifications of the PCI standard and the mechanical specifications of the IEEE 1101 and IEC 60297 series of standards. The board connector has been developed from the IEC 61076-4-101 series of 2.0 mm connectors. The mounting location and dimensions for the 2.0 mm connectors are specified in IEEE 1101.11. Some additional mechanical definitions for 2.0 mm connectors in the Eurocard format are being specified in the VITA 30 draft.

Other international standards are listed in the CompactPCI[®] standard for environmental and

Slave or peripheral boards need J1/P1 as a minimum, master or system boards need both J1/P1 and J2/P2 as a minimum. Backplanes should always have the full complement of



connectors to be compatible with any type of board. As opposed to the CPCI standard (pins numbered from bottom to top), the contact numbers on the connector are numbered from top to bottom (according to the IEC standard).

The front panel of CPCI cards may be equipped with additional keying pegs to code individual board types. There is also an extended pin length to remove any electro static charge before contacts on the rear connectors mate.

This pin also functions as a mechanical guide to position the board as straight as possible for insertion. This prevents pin bending and lowers the insertion force.

Some applications could require up to 500 pins to be pushed into sockets simultaneously.

Connectors for high availability applications (hot swap) come with 3 different lengths of pins for a staged sequence of mate or break of contact.

Connector J1/P1 carries the signals for a 32 bit PCI bus (see table of contact assignments for J1/P1). Connector J2/P2 on a system card has the additional signals for a 64 bit PCI bus and some user-defined I/O (see table of contact assignments for J2/P2). On slave cards all of J2/P2 might be user-defined I/O except the top row which carries the signals for geographical addressing. J3/P3 should be reserved for other system bus definitions. J4/P4 and J5/P5 are used for I/O or secondary buses, e.g. H.110 in telecom applications or for bridges into other buses like VMEbus.

This is used to accommodate two bus platforms in one card cage on one backplane.

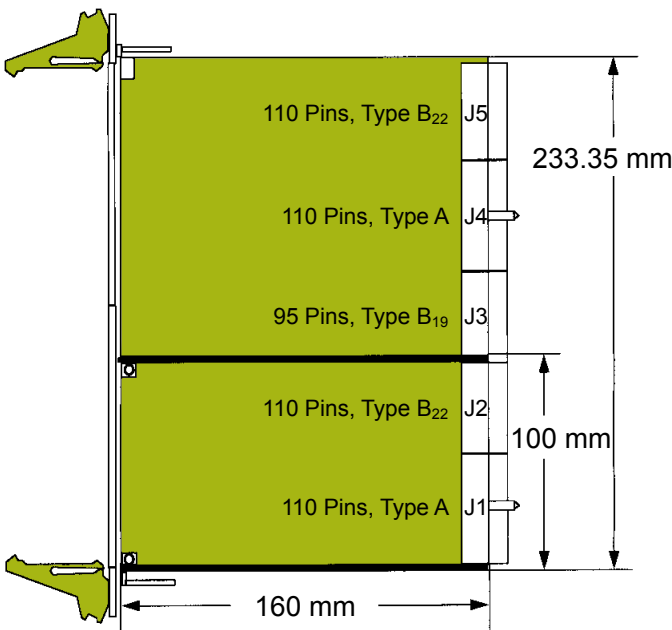

related specifications. This gives CompactPCI[®] a solid foundation of international standards and practices for mechanical robustness.

The board format is either a 3U or a 6U Eurocard as defined in IEC 60297. There are two or five connectors specified for 3U or 6U boards respectively. Connectors are numbered from J1/P1 through J5/P5 (bottom to top) on the board or backplane.

Contact assignment on CompactPCI[®] system position (J1/P1)

	a	b	c	d	e	
25	+5 V	REQ64#	ENUM#	+3,3 V	+5 V	25
24	AD[1]	+5 V	V(I/O)	AD[0]	ACK64#	24
23	+3,3 V	AD[4]	AD[3]	+5 V	AD[2]	23
22	AD[7]	GND	+3,3 V	AD[6]	AD[5]	22
21	+3,3 V	AD[9]	AD[8]	M66EN	C/BE[0]#	21
20	AD[12]	GND	V(I/O)	AD[11]	AD[10]	20
19	+3,3 V	AD[15]	AD[14]	GND	AD[13]	19
18	SERR#	GND	+3,3 V	PAR	C/BE[1]#	18
17	+3,3 V	SDONE	SBO#	GND	PERR#	17
16	DEVSEL#	GND	V(I/O)	STOP#	LOCK#	16
15	+3,3 V	FRAME#	IRDY#	GND	TRDY#	15
14	Key Area					14
13						13
12						12
11	AD[18]	AD[17]	AD[16]	GND	C/BE[2]#	11
10	AD[21]	GND	+3,3 V	AD[20]	AD[19]	10
9	C/BE[3]#	IDSEL	AD[23]	GND	AD[22]	9
8	AD[26]	GND	V(I/O)	AD[25]	AD[24]	8
7	AD[30]	AD[29]	AD[28]	GND	AD[27]	7
6	REQ#	GND	+3,3 V	CLK	AD[31]	6
5	Bus Reserved	Bus Reserved	RST#	GND	GNT#	5
4	Bus Reserved	GND	V(I/O)	INTP	INTS	4
3	INTA#	INTB#	INTC#	+5 V	INTD#	3
2	TCK	+5 V	TMS	TDO	TDI	2
1	+5 V	-12 V	TRST#	+12 V	+5 V	1
	a	b	c	d	e	

Contact assignment on CompactPCI[®] system position (J2/P2)

	a	b	c	d	e	
22	GA4	GA3	GA2	GA1	GA0	22
21	CLK6	GND	Reserved	Reserved	Reserved	21
20	CLK5	GND	Reserved	GND	Reserved	20
19	GND	GND	Reserved	Reserved	Reserved	19
18	Bus Reserved	Bus Reserved	Bus Reserved	GND	Bus Reserved	18
17	Bus Reserved	GND	PRST#	REQ6#	GNT6#	17
16	Bus Reserved	Bus Reserved	DEG#	GND	Bus Reserved	16
15	Bus Reserved	GND	FAL#	REQ5#	GNT5#	15
14	AD[35]	AD[34]	AD[33]	GND	AD[32]	14
13	AD[38]	GND	V(I/O)	AD[37]	AD[36]	13
12	AD[42]	AD[41]	AD[40]	GND	AD[39]	12
11	AD[45]	GND	V(I/O)	AD[44]	AD[43]	11
10	AD[49]	AD[48]	AD[47]	GND	AD[46]	10
9	AD[52]	GND	V(I/O)	AD[51]	AD[50]	9
8	AD[56]	AD[55]	AD[54]	GND	AD[53]	8
7	AD[59]	GND	V(I/O)	AD[58]	AD[57]	7
6	AD[63]	AD[62]	AD[61]	GND	AD[60]	6
5	C/BE[5]#	GND	V(I/O)	C/BE[4]#	PAR64	5
4	V(I/O)	Bus Reserved	C/BE[7]#	GND	C/BE[6]#	4
3	CLK4	GND	GNT3#	REQ4#	GNT4#	3
2	CLK2	CLK3	SYSEN#	GNT2#	REQ3#	2
1	CLK1	GND	REQ1#	GNT1#	REQ2#	1
	a	b	c	d	e	

In mechanical terms J1/P1 is a 25x5 matrix of contacts. Three rows of 5 contacts (rows 12 - 14) are not used for electrical contacts. Instead, plastic keys of different orientation and configuration are used to key board locations as to system or peripheral slot, voltage options, etc.

J2/P2 is a shortened connector with only 22 rows of contacts instead of 25 rows for a standard size. HARTING now offers monolithic versions with J1/P1 and J2/P2 combined in one single connector.

This combination together with some space left on the card to fit into guide rails makes maximum use of the 100 mm rear edge of the 3U Eurocard.

On a 6U card this connector setup is repeated on J4/P4 and J5/P5.

The J3/P3 connector is a shortened version of the 2.0 mm connector with 19 rows of 5 signal contacts.

The size results from the height of a 6U board (233 mm) which is more than double the height of a 3U board.

All connectors used for CompactPCI[®] are based on a 7 column pitch. The inner 5 columns are used for logic signals and power. The outer columns on either side are reserved for shielding or ground.



Executive Member

The VMEbus has evolved over a period of more than 25 years to become the leading bus architecture in open industrial applications. The specification is an ANSI norm, the original specification has been extended to become a draft standard VME64x ANSI/VITA 1.1-1997. This draft standard includes the specification for the 5-row DIN compatible connector (IEC 61076-4-113) and for a centre connector J0/P0 on 6U VME cards, which is identical to J3/P3 in *CompactPCI*[®] systems.

In VMEbus systems it is possible to use custom connectors in the J0/P0 area (e.g. coax connectors). To prevent problems with non-mating backplanes it is strongly recommended to use front panel keying. The IEEE 1101 documents J0/P0 can also be used with rear transition modules for pluggable I/O cabling. As mentioned above, the contacts on this connector may be bussed. One example is the ATM CellBus, which is in the process of being standardised. The bus on J0/P0 connectors might actually be a plug-on mezzanine backplane rather than conducting traces integrated into the backplane itself.

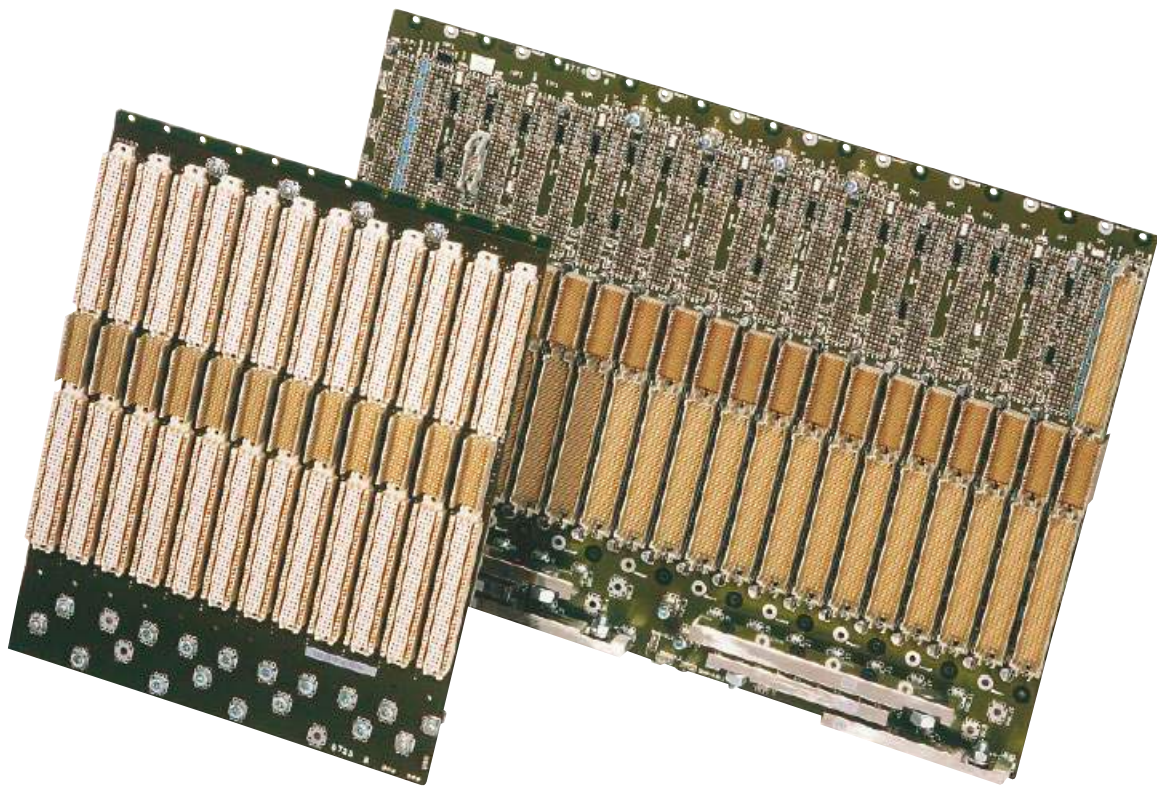

The 2.0 mm J0/P0 connector in VME64x systems is used for additional I/O, for new high speed sub busses or I/O for mezzanine modules, e.g. IP modules on VMEbus boards. The connector is placed on the Eurocard to work in combination with the non-metric original VMEbus connectors DIN 41612 type C or the newer 5-row connector har-bus[®] 64. The mounting location and dimensions for the J0/P0 VMEbus connector (IEC 61076-4-101) is specified in IEEE 1101.11. The VMEbus 2.0 mm connector uses 5 columns of signal contacts and optional two additional outer columns on either side for shielding. All 95 signal contacts are user defined.



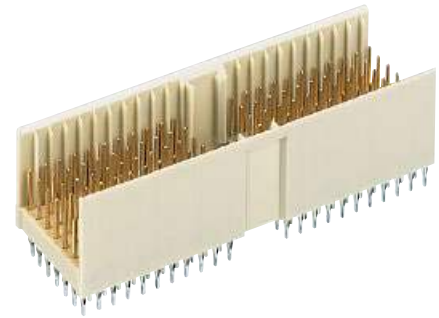

Male connectors, straight

Identification	No. of contacts	Contact length [mm]		Part number	Contact configuration
		mating side	termination side		
Type A	110	8.2	3.7	17 01 110 1201 17 01 110 2201	
Type A	132	8.2/ 11.2	3.7	17 01 132 1203 17 01 132 2203	
Type A	132	8.2/ 11.2	3.7/ 13.0/ 16.0	17 01 132 1007 17 01 132 2007	
Type A	154	8.2/ 11.2	3.7	17 01 154 1201 17 01 154 2201	
Type A	110	9.7	3.7	17 01 110 1204 17 01 110 2204	
Type A	154	9.7/ 11.2	3.7	17 01 154 1205 17 01 154 2205	

harbus
HM

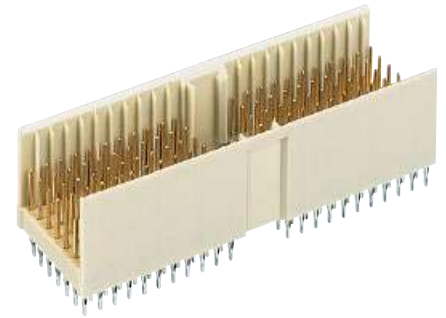

Male connectors, straight

Identification	No. of contacts	Contact length [mm] mating side	termination side	Part number	Contact configuration
Type A	110	8.2	13.0	17 01 110 1402 17 01 110 2402	
Type A	154	9.7/ 11.2	14.5/ 16.0	17 01 154 1001 17 01 154 2001	
Type A CompactPCI Position P1	154	8.2/ 9.7/ 11.2	3.7	17 01 154 1203 17 01 154 2203	
Type A CompactPCI Position P4	154	9.7/ 11.2	16.0	17 01 154 1604 17 01 154 2604	
Type A CompactPCI Position P4	154	8.2/ 9.7/ 11.2	16.0	17 01 154 1603 17 01 154 2603	
Type A CompactPCI hot swap Position P1	154	8.2/ 9.7/ 11.2	3.7	17 01 154 1204 17 01 154 2204	

harbus
HM

Thin print part numbers: performance level 1
Bold print part numbers: performance level 2
 Connector dimensions see page 11.14

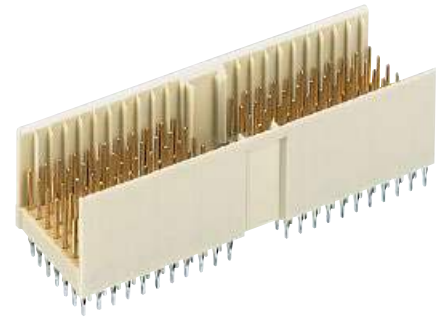

Male connectors, straight

Identification	No. of contacts	Contact length [mm] mating side	termination side	Part number	Contact configuration
Type A CompactPCI computer telephony Position P4	100	8.2/ 9.7/ 11.2	13.0/ 14.5/ 16.0	17 01 100 1001 17 01 100 2001	
Type A CompactPCI computer telephony Position P4	100	8.2/ 9.7/ 11.2	3.7	17 01 100 1201 17 01 100 2201	

Contact dimensions [mm]

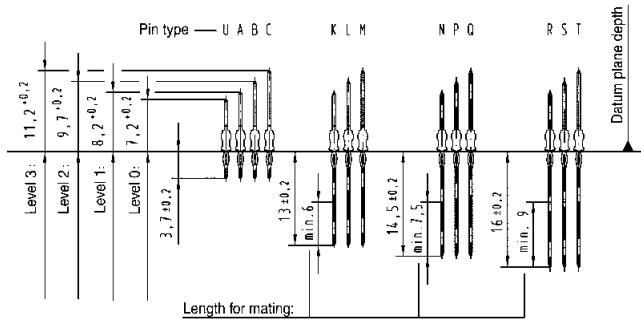

Connector dimensions [mm]

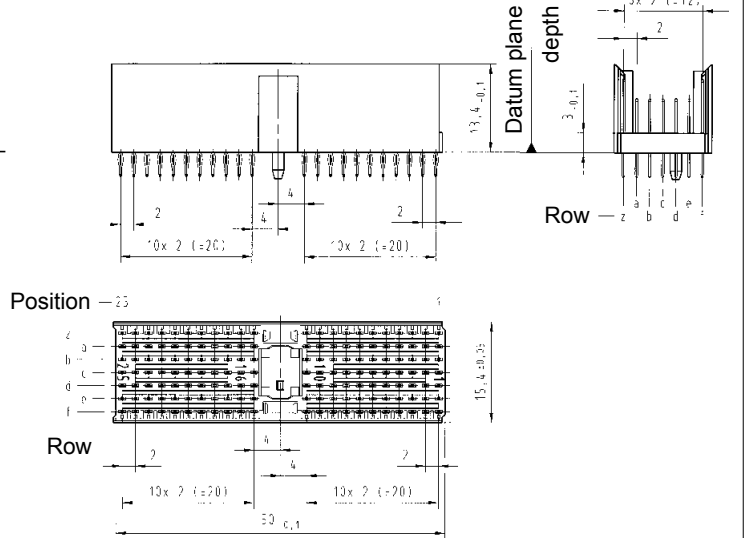

Board drillings

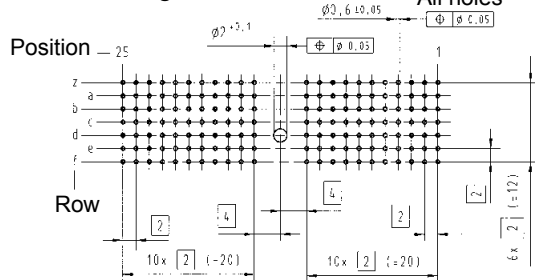

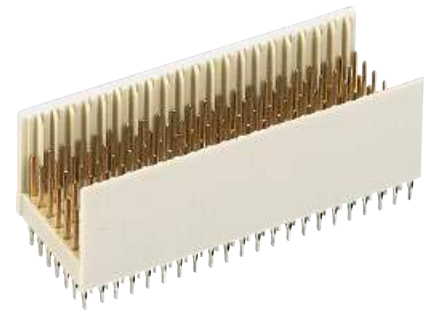

Male connectors, straight

Identification	No. of contacts	Contact length [mm] mating side	termination side	Part number	Contact configuration
Type B25	125	8.2	3.7	17 02 125 1201 17 02 125 2201	
Type B25	150	8.2/ 11.2	3.7	17 02 150 1201 17 02 150 2201	
Type B25	175	8.2/ 11.2	3.7	17 02 175 1201 17 02 175 2201	
Type B25	125	9.7/ 11.2	3.7	17 02 125 1205 17 02 125 2205	
Type B25	175	8.2/ 9.7/ 11.2	3.7	17 02 175 1202 17 02 175 2202	
Type B25	175	8.2/ 11.2	13.0/ 16.0	17 02 175 1006 17 02 175 2006	

harbus
HM

Thin print part numbers: performance level 1
Bold print part numbers: performance level 2
 Connector dimensions see page 11.18

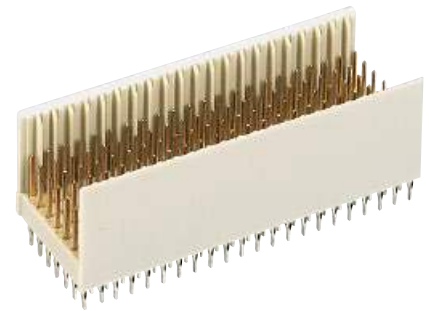

Male connectors, straight

Identification	No. of contacts	Contact length [mm]		Part number	Contact configuration
		mating side	termination side		
Type B22	110	8.2	3.7	17 04 110 1201 17 04 110 2201	
Type B22	154	8.2/ 11.2	3.7	17 04 154 1201 17 04 154 2201	
Type B22 CompactPCI Position P2	154	9.7/ 11.2	3.7	17 04 154 1203 17 04 154 2203	
Type B22 CompactPCI computer telephony	132	8.2/ 9.7/ 11.2	13.0/ 14.5/ 16.0	17 04 132 1001 17 04 132 2001	
Type B22 CompactPCI AB friendly	154	9.7/ 11.2	3.7/ 16.0	17 04 154 1010 17 04 154 2010	
Type B22 CompactPCI AB friendly	154	9.7/ 11.2	3.7/ 14.5/ 16.0	17 04 154 1002 17 04 154 2002	

harbus
HM

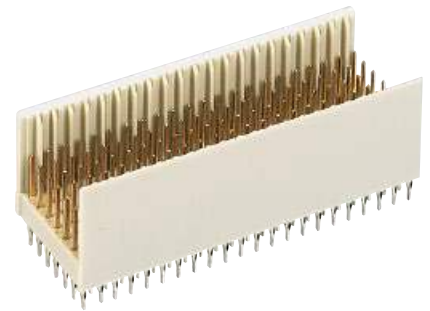

Male connectors, straight

Identification	No. of contacts	Contact length [mm]		Part number	Contact configuration
		mating side	termination side		
Type B19 VME Position J0	95	8.2	3.7	17 05 095 1201 17 05 095 2201	
Type B19 VME Position J0	133	8.2/ 11.2	3.7	17 05 133 1201 17 05 133 2201	
Type B19 VME Position J0	133	9.7/ 11.2	3.7	17 05 133 1203 17 05 133 2203	
Type B19 VME Position J0	95	8.2	13.0	17 05 095 1401 17 05 095 2401	
Type B19 CompactPCI AB friendly Position P3	133	9.7/ 11.2	3.7/ 16.0	17 05 133 1005 17 05 133 2005	
Type B19 Compact PCI Position P3 VME Position J0	133	8.2/ 11.2	16.0	17 05 133 1602 17 05 133 2602	

harbus
HM

Thin print part numbers: performance level 1
Bold print part numbers: performance level 2
 Connector dimensions see page 11.18

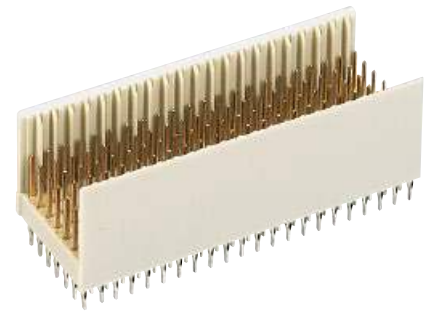

Male connectors, straight

Drawing

Dimensions in mm

Contact dimensions [mm]

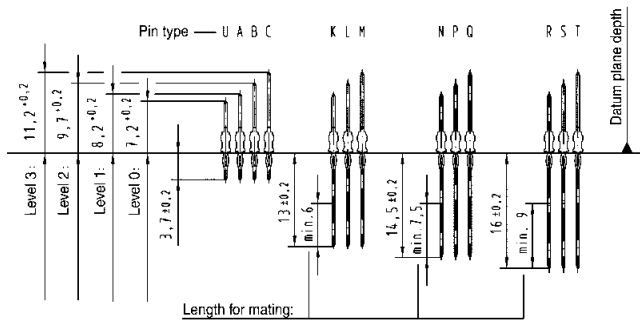

Connector dimensions [mm]

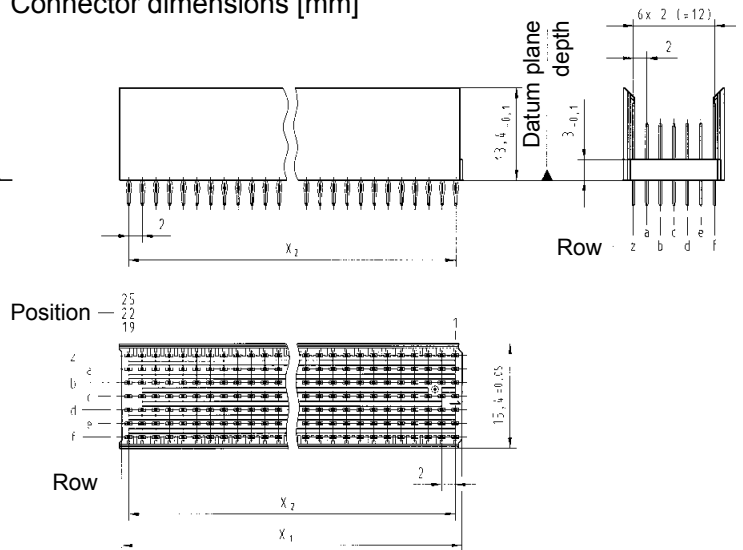

Board drillings

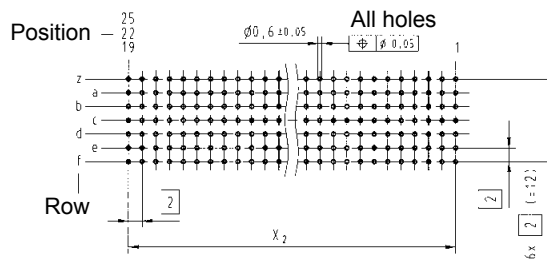

Contact positions	x ₁	x ₂
19	37.9	18 x 2 (= 36)
22	43.9	21 x 2 (= 42)
25	49.9	24 x 2 (= 48)

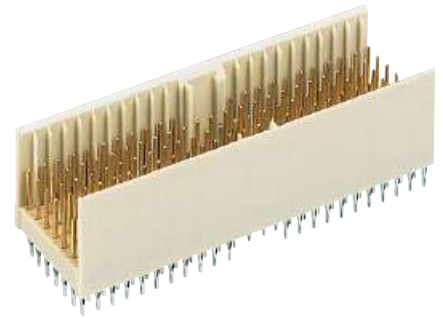

Male connectors, straight

Identification	No. of contacts	Contact length [mm] mating side	termination side	Part number	Contact configuration
Type AB ₂₅	125	8.2	3.7	17 15 125 1201 17 15 125 2201	
Type AB ₂₅	169	8.2/ 11.2	3.7	17 15 169 1201 17 15 169 2201	
Type AB ₂₅	169	8.2/ 11.2	13.0/ 16.0	17 15 169 1003 17 15 169 2003	

Contact dimensions [mm]

Connector dimensions [mm]

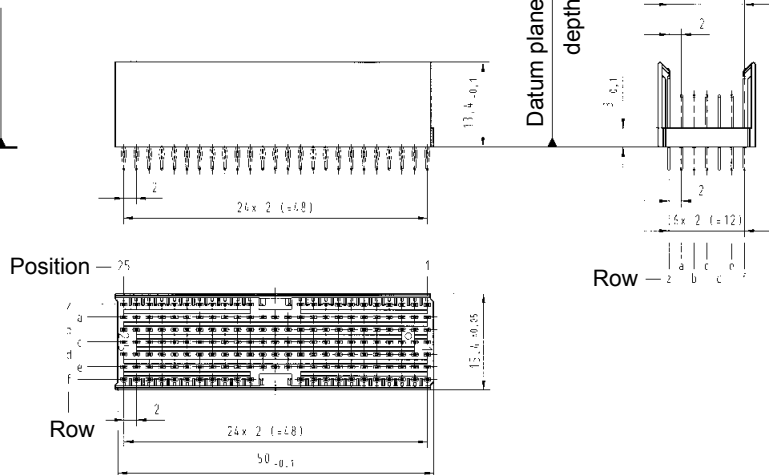
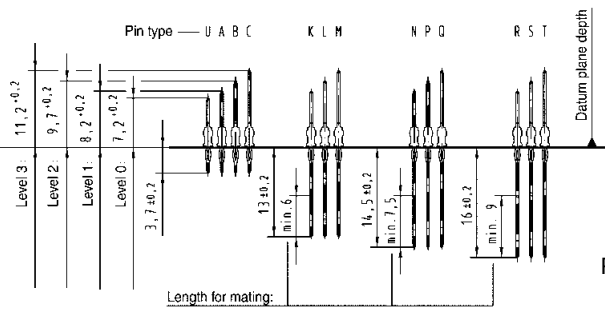

Board drillings

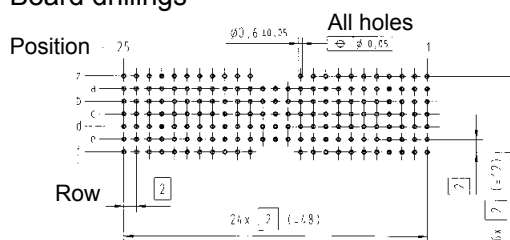



Male connectors, straight

Identification	No. of contacts	Contact length [mm]		Part number	Contact configuration
		mating side	termination side		
Type AB ₂₂	110	8.2	3.7	17 14 110 1201 17 14 110 2201	
Type AB ₂₂	146	8.2/ 11.2	3.7	17 14 146 1201 17 14 146 2201	
Type AB ₂₂	146	9.7/ 11.2	16.0	17 14 146 1601 17 14 146 2601	

Contact dimensions [mm]

Connector dimensions [mm]

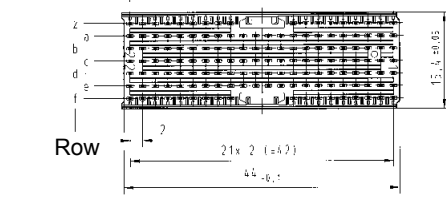
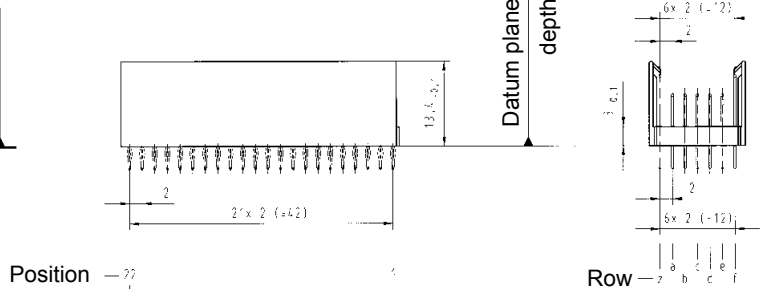
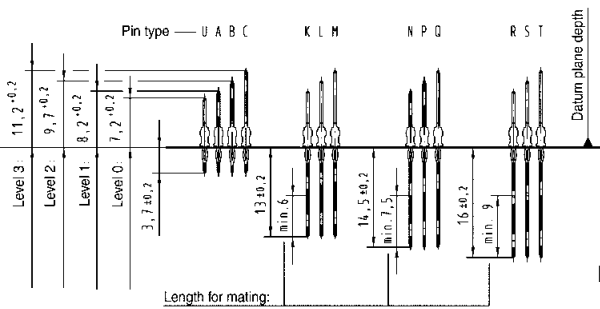

Board drillings

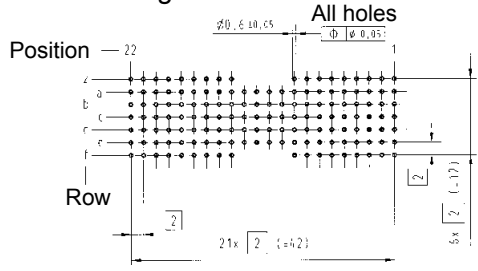

harbus HM

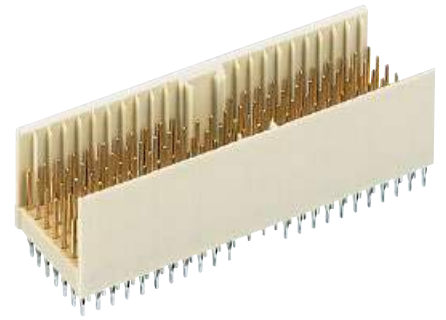

Male connectors, straight

Identification	No. of contacts	Contact length [mm] mating side	termination side	Part number	Contact configuration
Type AB ₁₉	95	8.2	3.7	17 13 095 1201 17 13 095 2201	
Type AB ₁₉	127	8.2/ 11.2	3.7	17 13 127 1201 17 13 127 2201	
Type AB ₁₉	127	9.7/ 11.2	16.0	17 13 127 1601 17 13 127 2601	

Contact dimensions [mm]

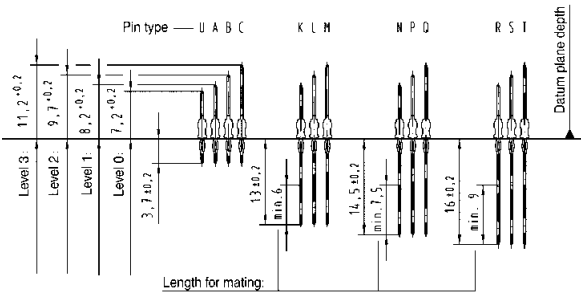

Connector dimensions [mm]

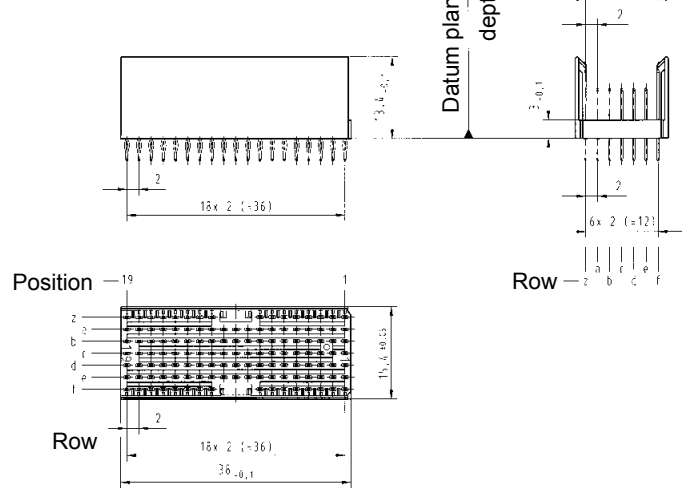

Board drillings

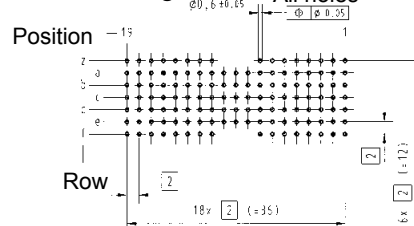



Male connectors, straight

Identification	No. of contacts	Contact length [mm]		Part number	Contact configuration
		mating side	termination side		
Type C	55	8.2	3.7	17 03 055 1201 17 03 055 2201	 11 10 9 8 7 6 5 4 3 2 1
Type C	77	8.2/ 11.2	3.7	17 03 077 1201 17 03 077 2201	 11 10 9 8 7 6 5 4 3 2 1
Type C	55	9.7	3.7	17 03 055 1202 17 03 055 2202	 11 10 9 8 7 6 5 4 3 2 1
Type C	77	9.7/ 11.2	3.7	17 03 077 1202 17 03 077 2202	 11 10 9 8 7 6 5 4 3 2 1
Type C	55	8.2	13.0	17 03 055 1401 17 03 055 2401	 11 10 9 8 7 6 5 4 3 2 1
Type C	66	8.2/ 11.2	13.0/ 16.0	17 03 066 1001 17 03 066 2001	 11 10 9 8 7 6 5 4 3 2 1

harbus
HM



Male connectors, straight

Identification	No. of contacts	Contact length [mm] mating side	termination side	Part number	Contact configuration
Type C	77	8.2/ 11.2	3.7/ 13.0	17 03 077 1001 17 03 077 2001	
Type C	77	8.2/ 11.2	16.0	17 03 077 1601 17 03 077 2601	

Contact dimensions [mm]

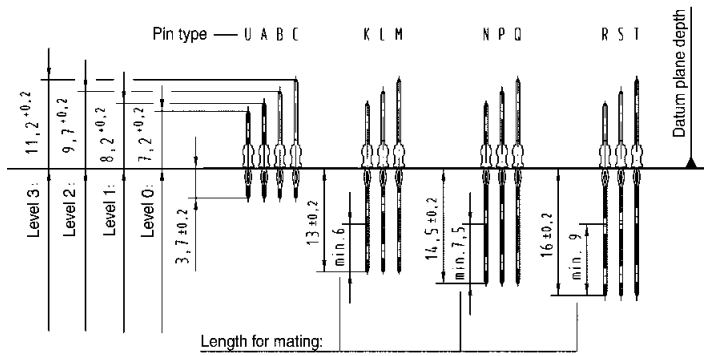

Connector dimensions [mm]

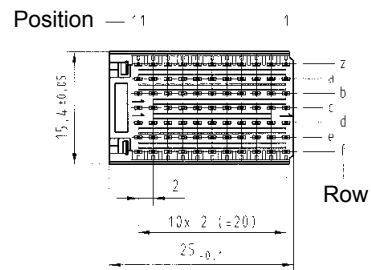
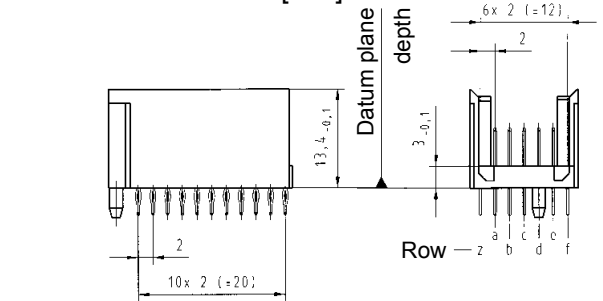

Board drillings

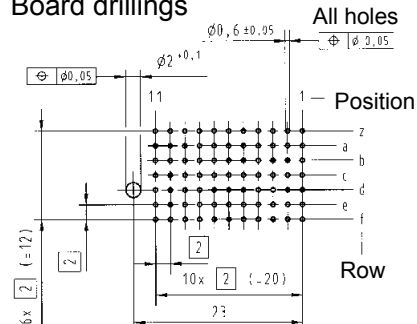

harbus
HM

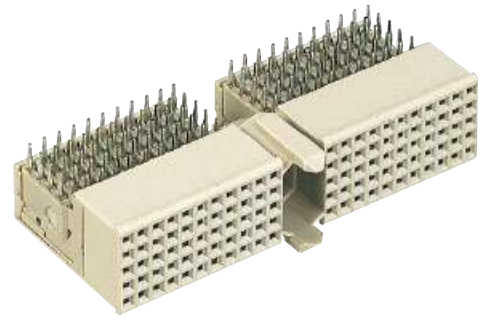

Female connectors, angled

Identification	No. of contacts	Contact length [mm] termination side	Part number
Type A	110	3.4	17 21 110 1101 17 21 110 2101
Type A with upper shield CompactPCI Positions J1, J4	110	3.4	17 21 110 1102 17 21 110 2102
Lower shield for type A connectors			17 21 000 4102
Type A with split upper shield CompactPCI computer telephony Position J4	90	3.4	17 21 090 1103 17 21 090 2103
Lower shield for type A connectors (rows 1 – 5) CompactPCI computer telephony			17 29 000 4102
Lower shield for type A connectors (rows 15 – 25) CompactPCI computer telephony			17 23 000 4102

harbus
HM

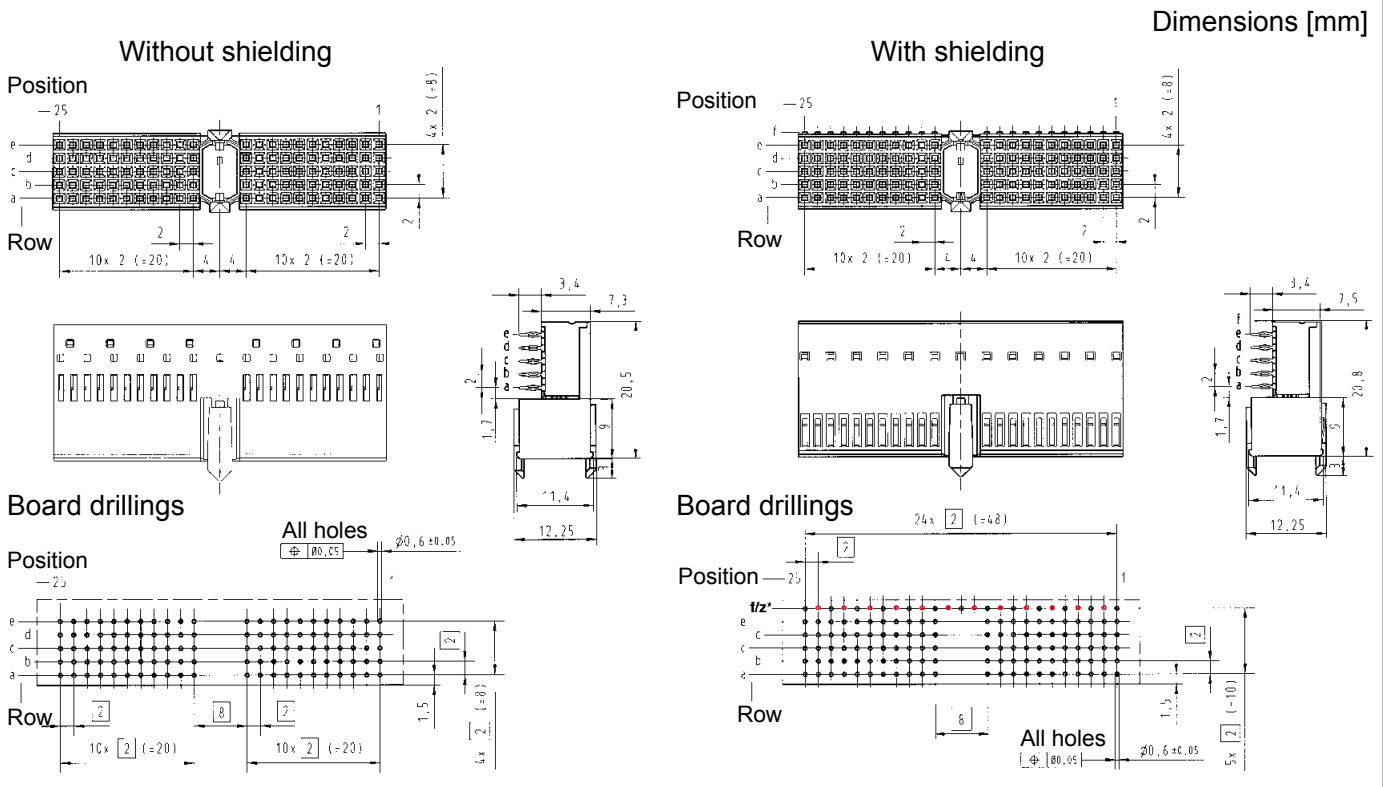

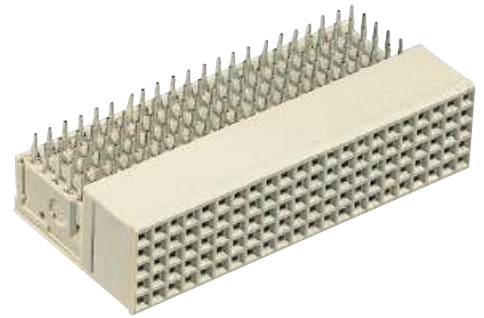

Female connectors, angled

Identification	No. of contacts	Contact length [mm] termination side	Part number
Type B19 VME, Position P0	95	3.4	17 25 095 1101 17 25 095 2101
Type B19 with upper shield CompactPCI, Position J3 – VME, Position P0	95	3.4	17 25 095 1102 17 25 095 2102
Lower shield for type B19 connectors			17 25 000 4102
Type B22	110	3.4	17 24 110 1101 17 24 110 2101
Type B22 with upper shield CompactPCI, Positions J2, J5	110	3.4	17 24 110 1102 17 24 110 2102
Lower shield for type B22 connectors			17 24 000 4102
Type B25	125	3.4	17 22 125 1101 17 22 125 2101
Type B25 with upper shield	125	3.4	17 22 125 1102 17 22 125 2102
Lower shield for type B25 connectors			17 22 000 4102

Contact positions	X ₁	X ₂
19	37.9	18 x 2 (= 36)
22	43.9	21 x 2 (= 42)
25	49.9	24 x 2 (= 48)

Dimensions [mm]

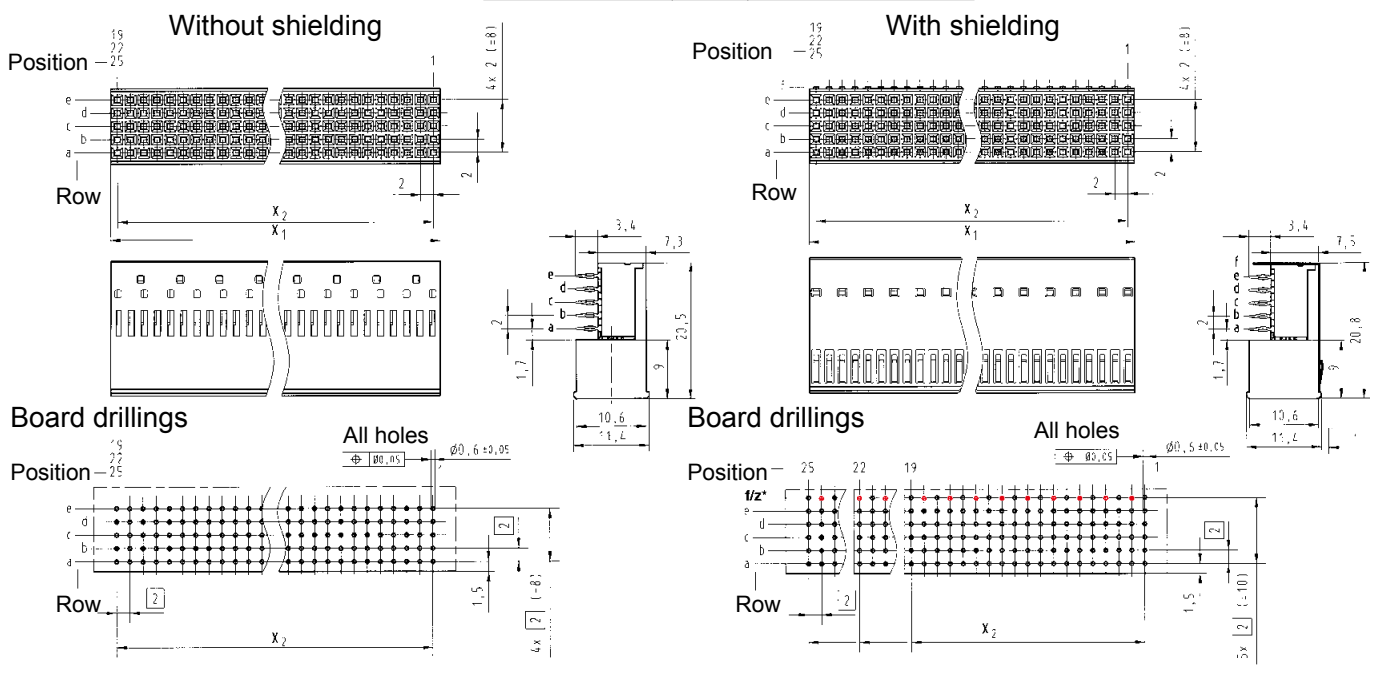

Thin print part numbers: performance level 1
Bold print part numbers: performance level 2

* hole on even contact numbers only needed for lower shielding

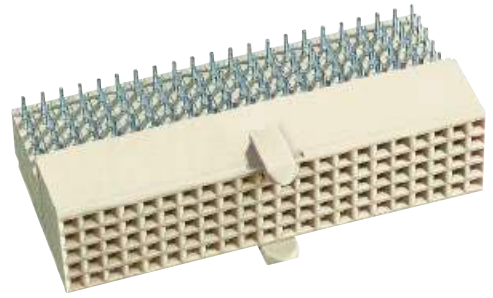

Female connectors, angled

Identification	No. of contacts	Contact length [mm] termination side	Part number
Type AB ₁₉	95	3.4	17 33 095 1101 17 33 095 2101
Type AB ₁₉ with upper shield CompactPCI, Position RJ3	95	3.4	17 33 095 1102 17 33 095 2102
Lower shield for type AB ₁₉ connectors			17 33 000 4102
Type AB ₂₂	110	3.4	17 34 110 1101 17 34 110 2101
Type AB ₂₂ with upper shield CompactPCI, Positions RJ2, RJ5	110	3.4	17 34 110 1102 17 34 110 2102
Lower shield for type AB ₂₂ connectors			17 34 000 4102
Type AB ₂₅	125	3.4	17 35 125 1101 17 35 125 2101
Type AB ₂₅ with upper shield	125	3.4	17 35 125 1102 17 35 125 2102
Lower shield for type AB ₂₅ connectors			17 21 000 4102

Contact positions	X ₁	X ₂
19	37.9	18 x 2 (= 36)
22	43.9	21 x 2 (= 42)
25	49.9	24 x 2 (= 48)

Dimensions [mm]

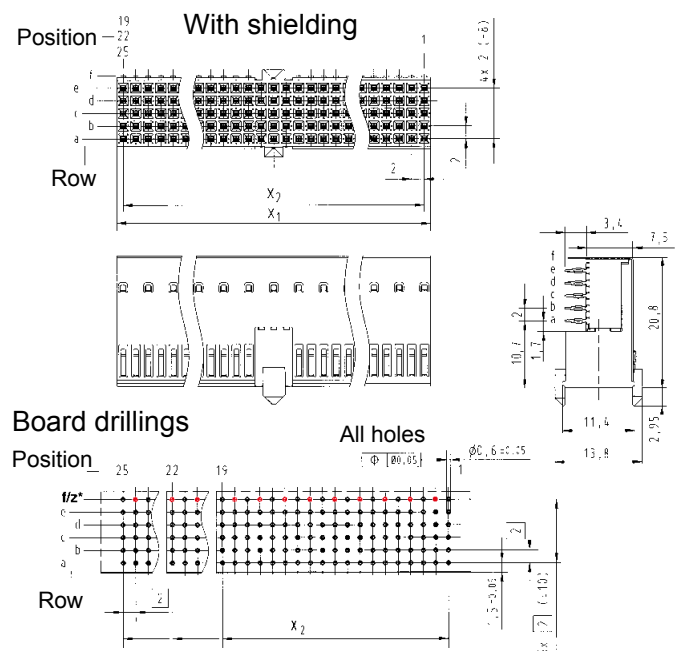
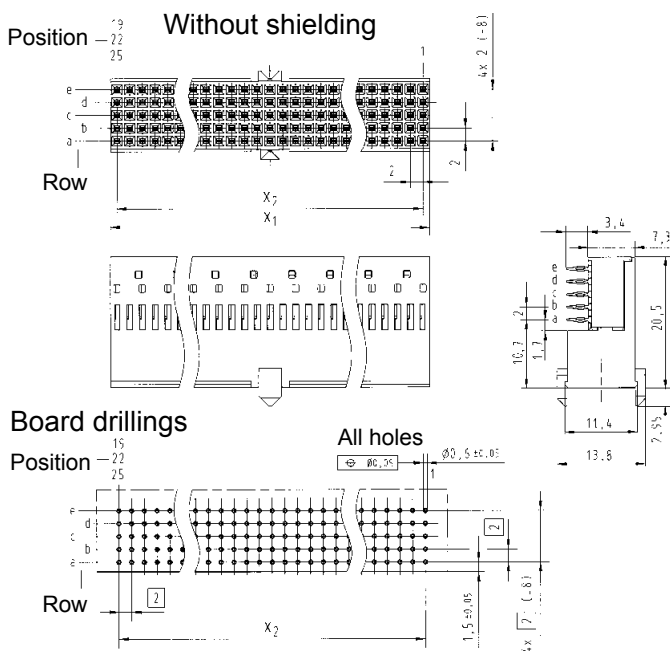

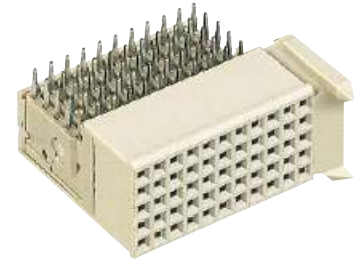

Female connectors, angled

Identification	No. of contacts	Contact length [mm] termination side	Part number
Type C	55	3.4	17 23 055 1101 17 23 055 2101
Type C with upper shield	55	3.4	17 23 055 1102 17 23 055 2102
Lower shield for type C connectors			17 23 000 4102

harbus
HM

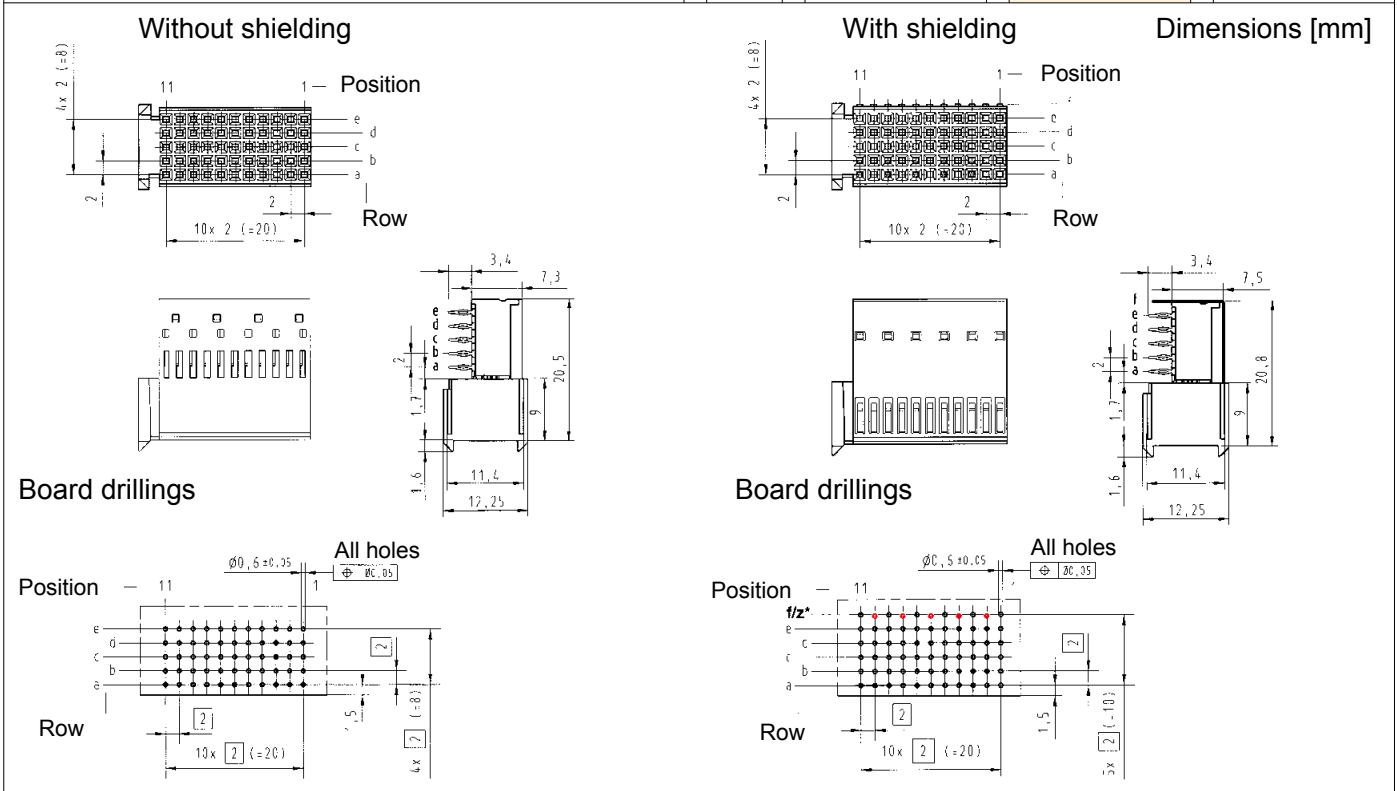

Thin print part numbers: performance level 1
Bold print part numbers: performance level 2

* hole on even contact numbers only needed for lower shielding



Male connectors, straight

Identification	No. of contacts	Contact length [mm]		Part number	Contact configuration
		mating side	termination side		
Type Monoblock 47	220	8.2	3.7	17 06 220 1201 17 06 220 2201	
Type Monoblock 47	308	8.2/ 11.2	3.7	17 06 308 1201 17 06 308 2201	
Type Monoblock 47	220	9.7	3.7	17 06 220 1202 17 06 220 2202	
Type Monoblock 47 CompactPCI Positions P1 and P2	308	8.2/ 9.7/ 11.2	3.7	17 06 308 1202 17 06 308 2202	
Type Monoblock 47 CompactPCI hot swap	308	8.2/ 9.7/ 11.2	3.7	17 06 308 1203 17 06 308 2203	
Type Monoblock 47 CompactPCI computer telephony	232	8.2/ 9.7/ 11.2	3.7	17 06 232 1201 17 06 232 2201	

harbus
HM

Thin print part numbers: performance level 1
Bold print part numbers: performance level 2
 Connector dimensions see page 11.29



Male connectors, straight

Identification	No. of contacts	Contact length [mm]		Part number	Contact configuration
		mating side	termination side		
Type Monoblock 47 CompactPCI I/O	308	8.2/ 9.7/ 11.2	3.7/ 16.0	17 06 308 1001 17 06 308 2001	
Type Monoblock 47 CompactPCI AB friendly Positions P4 and P5	308	9.7/ 11.2	3.7/ 16.0	17 06 308 1005 17 06 308 2005	

Contact dimensions [mm]

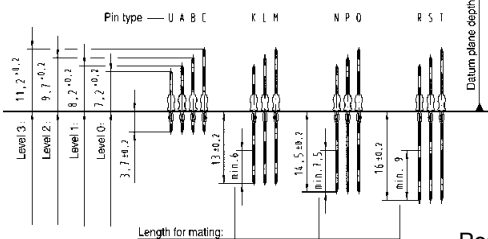

Connector dimensions [mm]

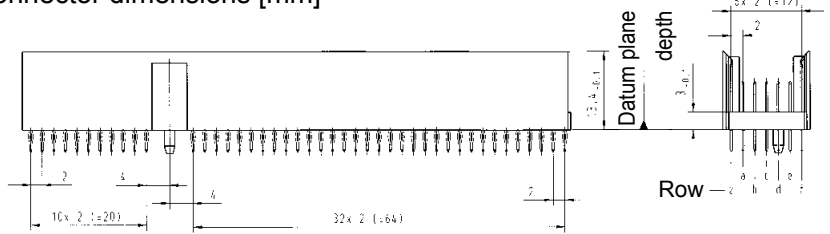

Position

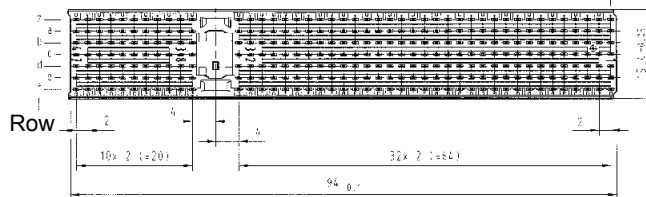

Board drillings

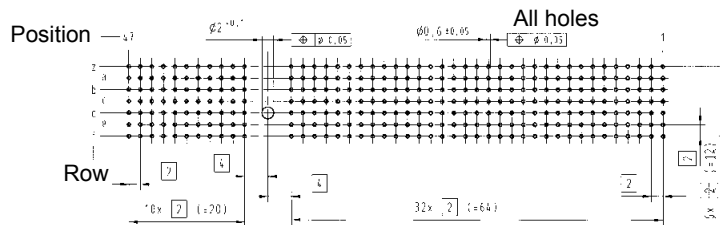

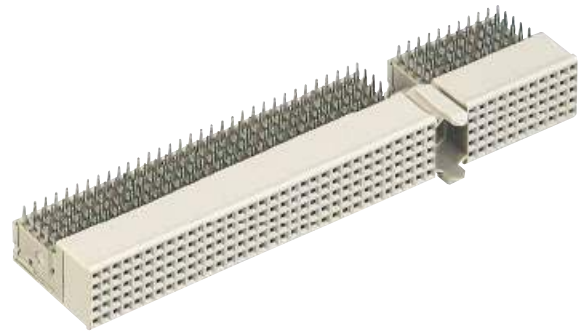

Female connectors, angled

Identification	No. of contacts	Contact length [mm] termination side	Part number
Type Monoblock 47	220	3.4	17 26 220 1101 17 26 220 2101
Type Monoblock 47 with upper shield	220	3.4	17 26 220 1102 17 26 220 2102
Type Monoblock 47 with upper shield CompactPCI computer telephony	200	3.4	17 26 200 1103 17 26 200 2103
Lower shield for type Monoblock 47 connectors			17 26 000 4102
Lower shield for type Monoblock 47 connectors (rows 1 – 22) CompactPCI computer telephony			17 24 000 4102
Lower shield for type Monoblock 47 connectors (rows 23 – 27) CompactPCI computer telephony			17 29 000 4102
Lower shield for type Monoblock 47 connectors (rows 37 – 47) CompactPCI computer telephony			17 23 000 4102

harbus
HM

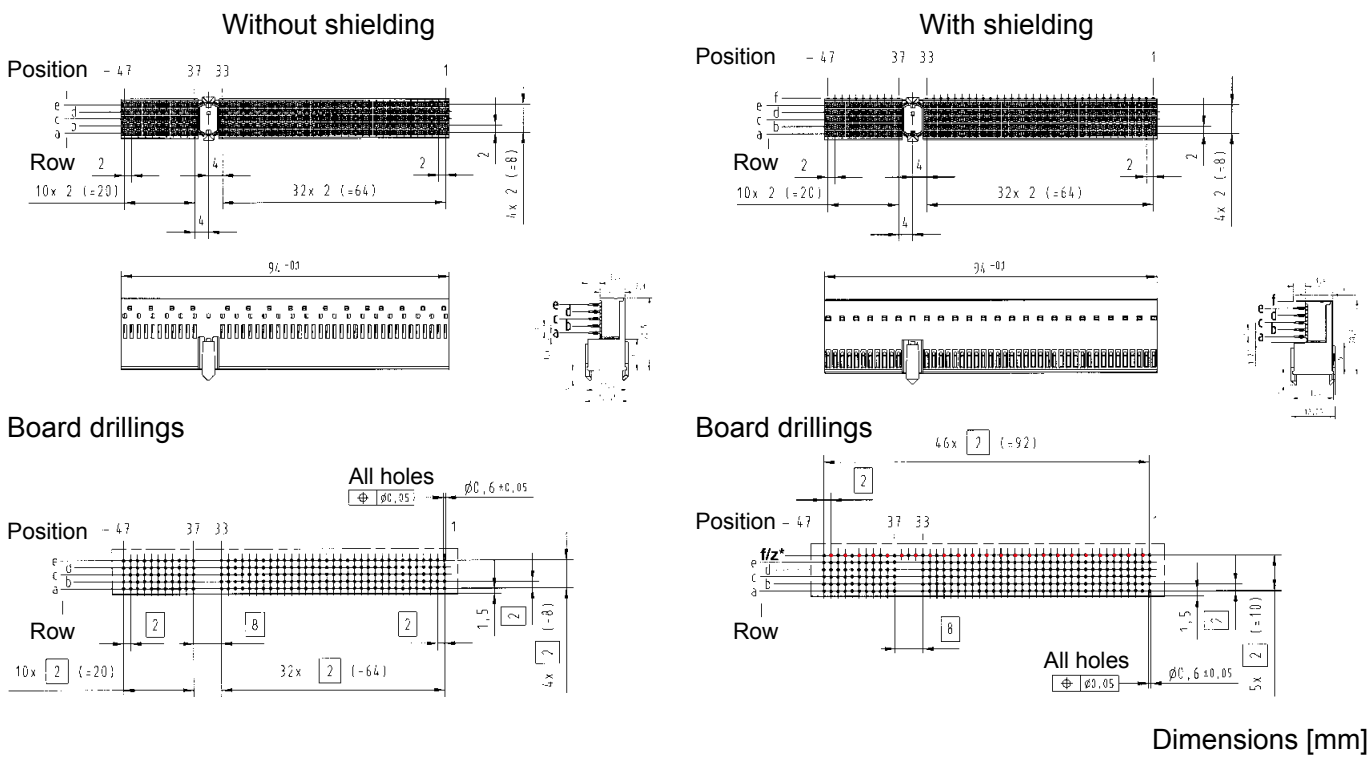

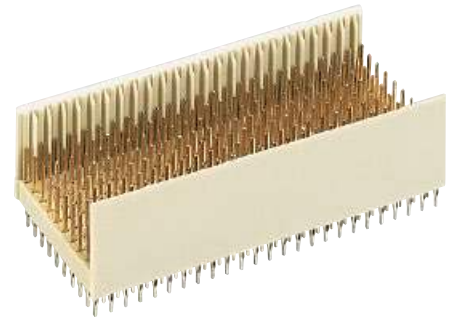

Male connectors, straight

Identification	No. of contacts	Contact length [mm] mating side	termination side	Part number	Contact configuration
Type E	200	8.2	3.7	17 12 200 1201 17 12 200 2201	
Type E	250	8.2/ 11.2	3.7	17 12 250 1201 17 12 250 2201	
Type E	250	9.7/ 11.2	14.5/ 16.0	17 12 250 1001 17 12 250 2001	

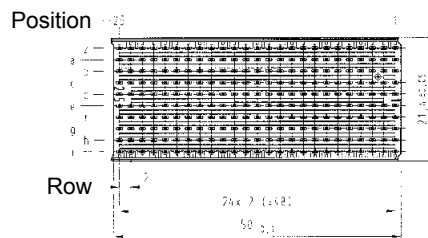
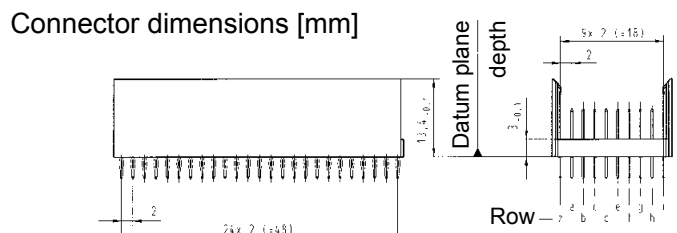
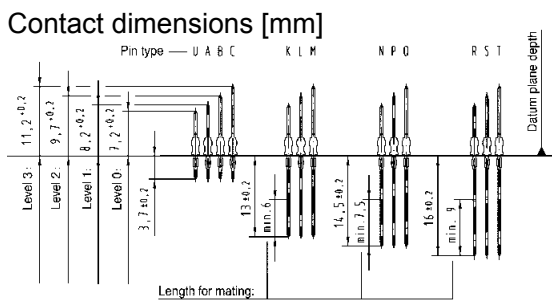

Board drillings

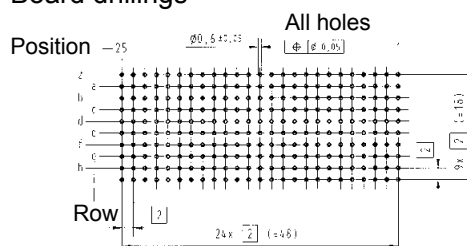

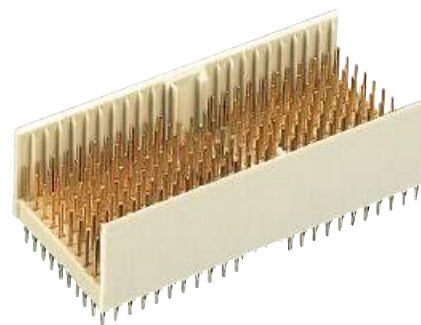

Male connectors, straight

Identification	No. of contacts	Contact length [mm] mating side	termination side	Part number	Contact configuration
Type DE	200	8.2	3.7	17 10 200 1201 17 10 200 2201	
Type DE	244	8.2/ 11.2	3.7	17 10 244 1201 17 10 244 2201	
Type DE	244	9.7/ 11.2	14.5/ 16.0	17 10 244 1001 17 10 244 2001	

Contact dimensions [mm]

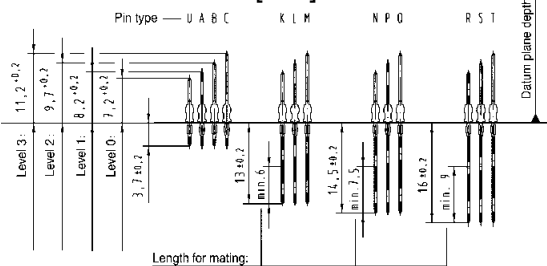

Connector dimensions [mm]

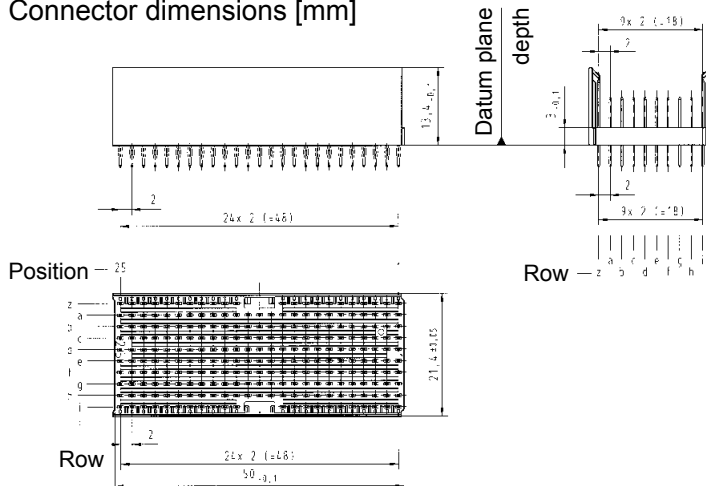

Board drillings

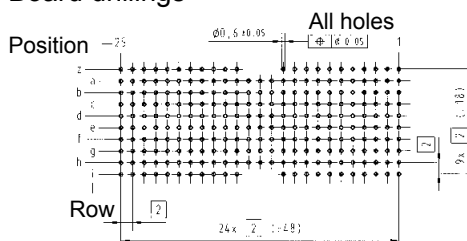

The **harbus[®] HM** Power connector is designed according to the OBSAI Specification V 1.1. It is well-suited to be used in conjunction with 2 mm **harbus[®] HM** connectors. The durability is according to IEC 61076-4-101 (250 mating cycles).

The straight female connector for the backplane is fitted with press-in contacts, the right angled male connector for daughter cards can be supplied with either, press-in or PIHIR (Pin In Hole Intrusive Reflow) termination.

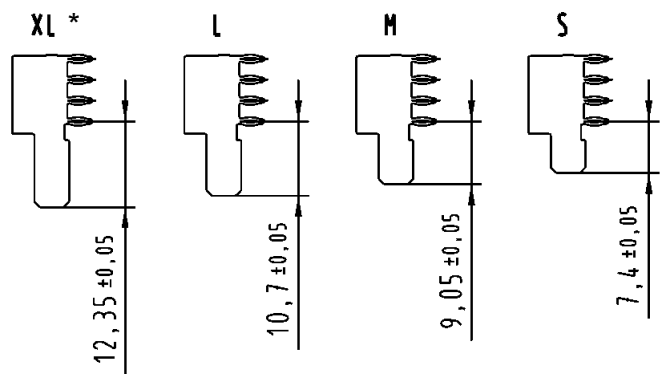

The compact, high temperature moulding can be loaded with up to four high current contacts. Four different contact lengths are available from 7.4 mm to 12.35 mm. This makes sequenced and non-sequenced loadings possible (e.g. with GND and ENA). Any other contact assignments, also partially loaded, are available on request.

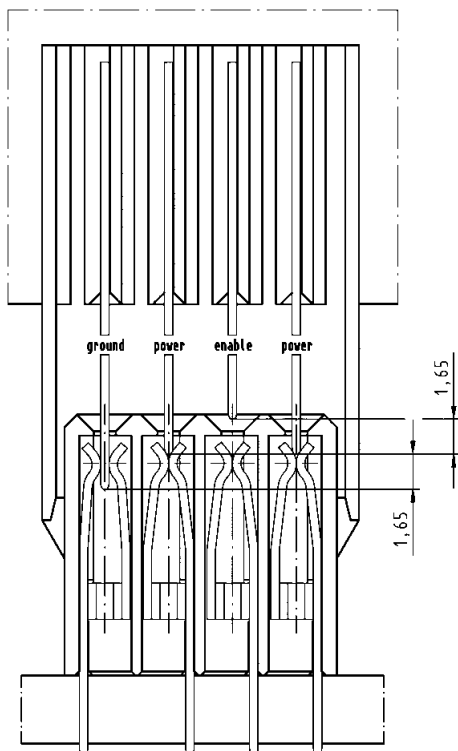

Loaded with four power contacts, each contact can carry up to 20 A @ 70 °C / 80 % derating.

With a configuration of two power contacts, GND and ENA, the current carrying capacity is even up to 23 A @ 70 °C / 80 % derating per contact.

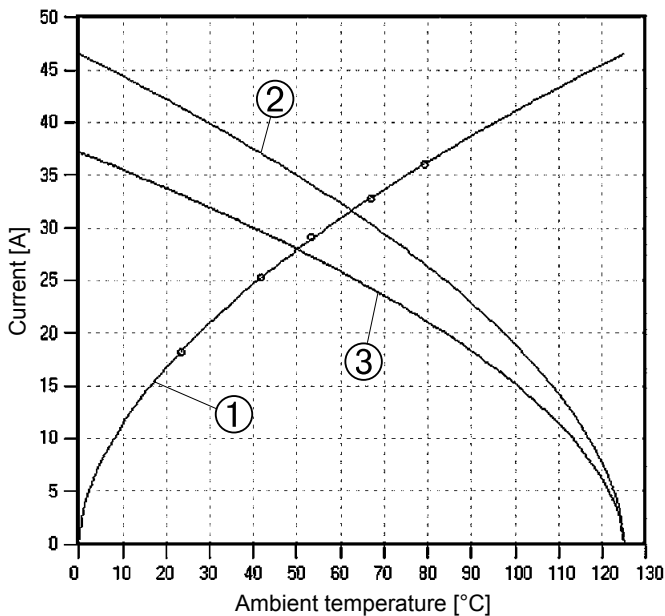

- ① Temperature raise
- ② Derating
- ③ Derating curve at $I_{max} \times 0.8$ (DIN EN 60512-5-2)

The distance between adjacent contacts is 3 mm, which enables wider pcb traces, larger solder paste areas and an improved heat dissipation. For the female backplane connector no special tooling is necessary due to the flatrock design. For the male connector HARTING offers a special press-in tool (see chapter 20).

HARTING's **harbus[®] HM** Signal and Power connectors meet OBSAI (Open Base Station Architecture Initiative) specifications and provide a reliable and cost effective solution for connecting plug-in units to the backplane. The connector solutions available from the HARTING technology group will offer full compatibility and intermateability with base station modules.

Benefits:

- Small form factor
- High current rating up to 23 A per contact (OBSAI configuration)
- 3 level staggering (or even 4)
- Flatrock design
- Matched with **harbus[®] HM** 2 mm connectors

* Type XL on request

Design according	: OBSAI System Spezifikation V 1.1
Approvals Underwriters Laboratories Inc.®	:  us with their respective ratings documented in file E 102079
Number of contacts	: up to 4
Contact spacing	: 3.00 mm
Clearance and creepage distances between contacts	: > 2.3 mm
Working current	: 23 A max. (OBSAI configuration) 20 A max. (fully loaded with power contacts)
Test voltage $U_{r.m.s.}$: AC 1500 V min.
Contact resistance	: < 1 mΩ
Insulation resistance:	: > 10 GΩ
Temperature range	: - 55 °C ... + 125 °C
during reflow soldering	220 °C for 2 minutes, 260 °C max. short-term
Durability as per IEC 61 076-4-101	: <i>Performance level 2 = 250 mating cycles in total.</i> First 125 mating cycles, then 4 days gas test using 0.5 ppm SO ₂ and 0.1 ppm H ₂ S (at 25 + 2 °C and 75 + 3 % humidity). Measurement of contact resistance. The remaining 125 mating cycles are subject to measurement of contact resistance and visual inspection. No abrasion of the contact finish through to the base material. No functional impairment.
Termination technique	
Male connectors	: Press-in or solder termination, suitable for (lead-free) pin-in-hole reflow soldering
Female connectors	: Press-in termination
Mating force	: max. 4 N / contact
Withdrawal force	: min. 0.5 N / contact
Materials	
Mouldings	: Thermoplastic resin, glass-fibre filled, UL 94-V0
Contacts	: Copper alloy
Contact surface	: Selectively gold plated (contact zone)
Contact styles	: Standard, leading, lagging
Packaging	
Tube	: Male and female connectors
Tape & Reel	: On request for male solder connectors

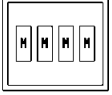
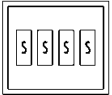
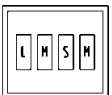
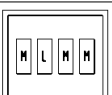

Male connectors angled, with press-in termination

Identification	No. of contacts	Contact length [mm] termination side	Part number	Contact loading
Connector with same sized contacts	4	2.8	17 61 004 2102	 Position — 4 3 2 1
Connector with same sized contacts	4	2.8	17 61 004 2103	 Position — 4 3 2 1
Connector with leading/lagging contacts OBSAI configuration	4	2.8	17 61 004 2101	 Position — 4 3 2 1
Connector with leading contact	4	2.8	17 61 004 2104	 Position — 4 3 2 1

Contact dimensions [mm]

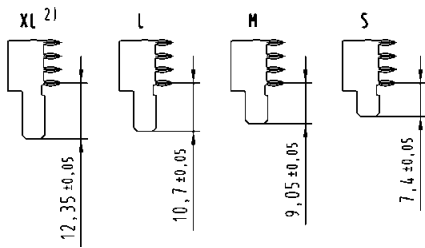

Connector dimensions [mm]

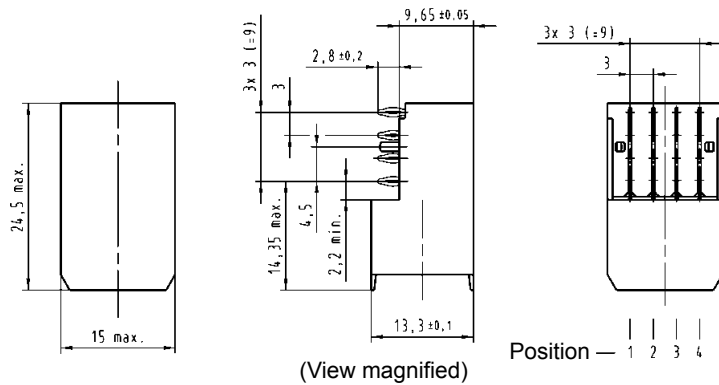

Board drillings

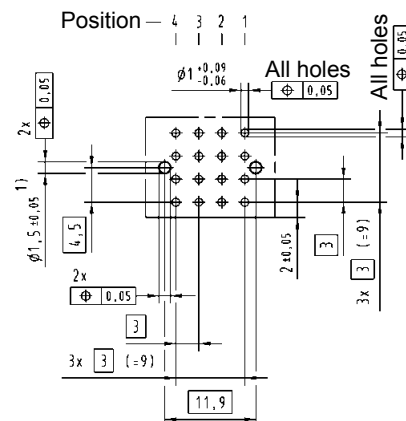

1) Non-metallized drillings
2) Type XL on request
Tooling see chapter 20



Male connectors angled, with solder (SMC) termination

Identification	No. of contacts	Contact length [mm] termination side	Part number	Contact loading
Connector with same sized contacts	4	2.5	17 61 004 2802	 Position — 4 3 2 1
Connector with leading/lagging contacts OBSAI configuration	4	2.5	17 61 004 2801	 Position — 4 3 2 1

Contact dimensions [mm]

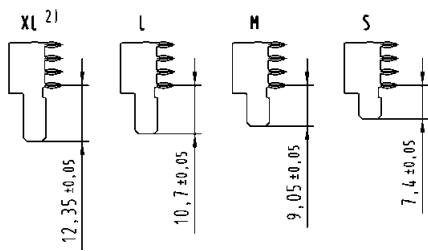

Connector dimensions [mm]

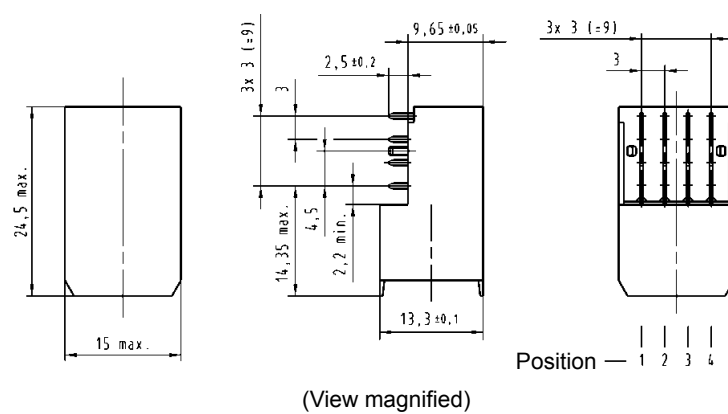

Board drillings

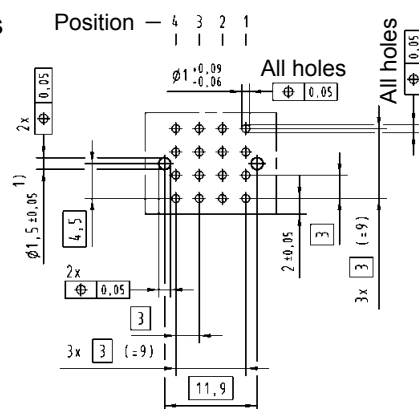

1) Non-metallized drillings
2) Type XL on request



Female connector straight, with press-in termination

Identification	No. of contacts	Contact length [mm] termination side	Part number
Connector with same sized contacts	4	3.7	17 66 004 2201

Connector dimensions [mm]

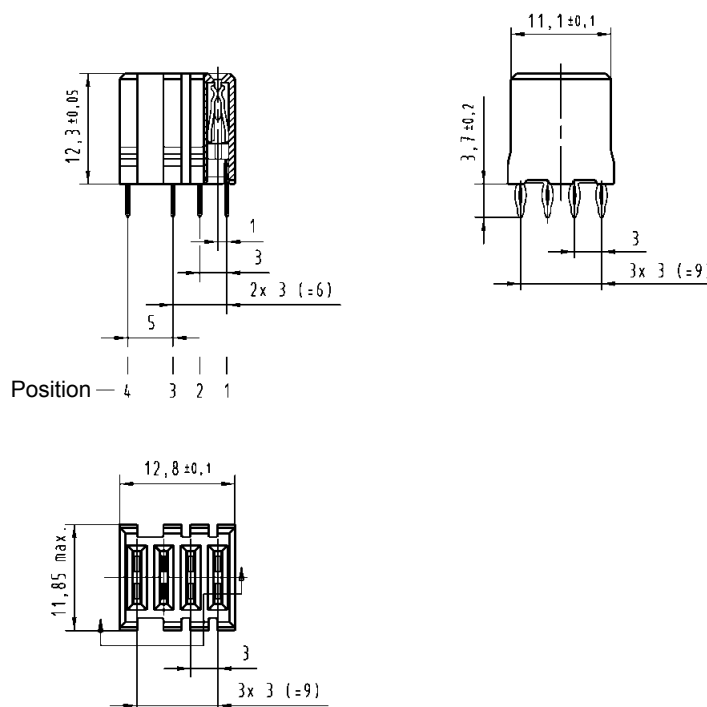

Board drillings

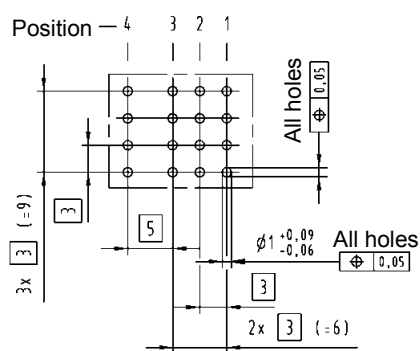

Coding keys are used to prevent mismatching of boards. They can be inserted into the multifunctional area of male and female connectors with special tooling. This can be easily done after the connectors have been pressed in.

Coding keys have different bright and pre-defined RAL colours to simplify the identification. In the table below the colours and code numbers in acc. with the IEC 61076-4-101 are listed. They are used for the following applications:

- Cadmium yellow for CompactPCI to identify 3.3 V bus signalling
- Brilliant blue for CompactPCI to identify 5.0 V bus signalling
- Reseda green to prevent accidental board insertion in VME64x on CompactPCI applications
- Strawberry red to prevent accidental board insertion in telephony applications
- Pastel orange for user defined bus
- Nut brown for rear I/O and user I/O

Coding keys for male connectors

Coding keys for female connectors

Coding key	Code number	Colour	Part number
	3568	Pastel orange RAL 2003	17 79 000 0010
	3478	Steel blue RAL 5011	17 79 000 0011
	3467	Slate grey RAL 7015	17 79 000 0012
	3456	Cadmium yellow RAL 1021 for CPCI, 3.3 V	17 79 000 0013
	2578	Reseda green Ral 6011	17 79 000 0014
	1567	Brilliant blue RAL 5007 for CPCI, 5.0 V	17 79 000 0015
	1356	Blue lilac RAL 4005	17 79 000 0016
	1248	Strawberry red RAL 3018	17 79 000 0018
	1236	Nut brown RAL 8011	17 79 000 0019

Coding key	Code number	Colour	Part number
	1247	Pastel orange RAL 2003	17 79 000 0020
	1256	Steel blue RAL 5011	17 79 000 0021
	1258	Slate grey RAL 7015	17 79 000 0022
	1278	Cadmium yellow RAL 1021 for CPCI, 3.3 V	17 79 000 0023
	1346	Reseda green Ral 6011	17 79 000 0024
	2348	Brilliant blue RAL 5007 for CPCI, 5.0 V	17 79 000 0025
	2478	Blue lilac RAL 4005	17 79 000 0026
	3567	Strawberry red RAL 3018	17 79 000 0028
	4578	Nut brown RAL 8011	17 79 000 0029

HARTING's *harbus® HM* shrouds protect the pins protruding the rear side of the backplane from irregular mating tolerances, thus ensuring a quality connection.

To accommodate pcb thickness, from 1.6 up to 4 mm nominal, the shrouds have integrated standoffs of corresponding height.

Thus forming a one piece solution that reduces assembling cost significantly.

The shroud can be mounted without the additional requirement of spacers to ensure the desired pin lengths on the rear side of the pcb.

Fixing of the component is carried out on the rear post via a smooth friction fit process.

For ease of assembly the same tooling as for the press-in connectors on the front side is utilised for assembly.

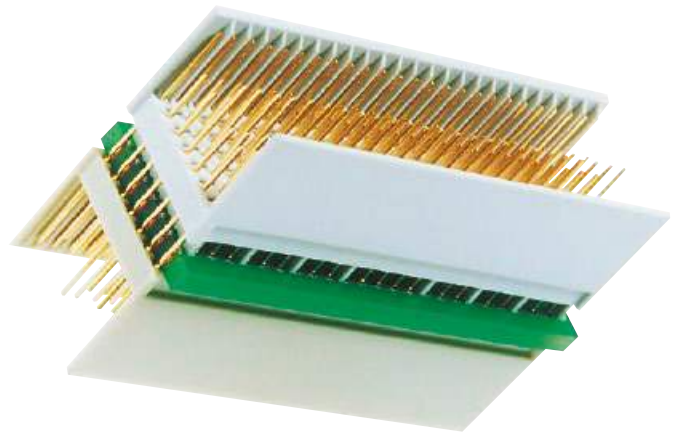

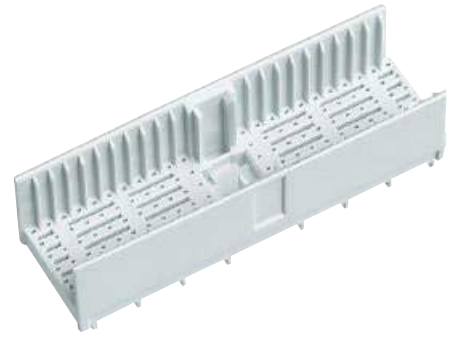

Identification	Board thickness [mm]	Part number
Type A shroud 25 positions	1.6 ± 0.4	17 70 000 1001
	2.4 ± 0.4	17 70 000 1002
	3.2 ± 0.4	17 70 000 1003
	4.0 ± 0.4	17 70 000 1004

Dimensions

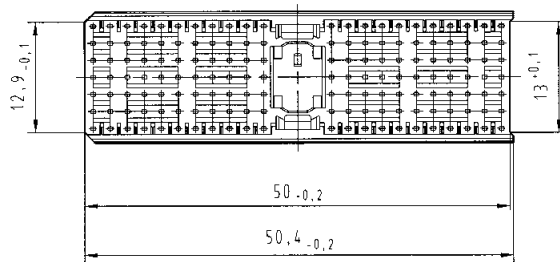
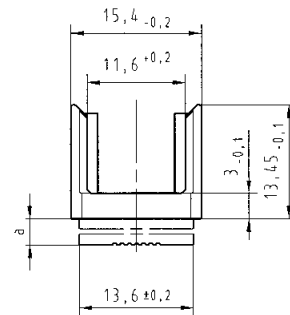
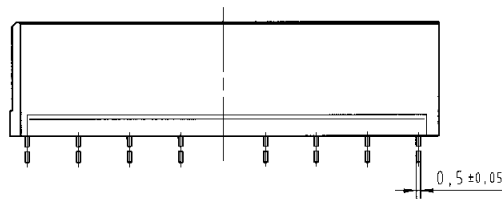
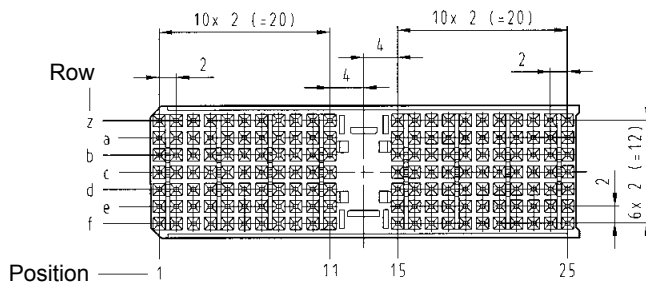

Board thickness [mm]	a [mm]
1.6 ± 0.4	3.1 ± 0.05
2.4 ± 0.4	2.3 ± 0.05
3.2 ± 0.4	1.5 ± 0.05
4.0 ± 0.4	0.7 ± 0.05



Identification	Board thickness [mm]	Part number
Type B shroud 25 positions	1.6 ± 0.4	17 70 000 2001
	2.4 ± 0.4	17 70 000 2002
	3.2 ± 0.4	17 70 000 2003
	4.0 ± 0.4	17 70 000 2004
22 positions	1.6 ± 0.4	17 70 000 4001
	2.4 ± 0.4	17 70 000 4002
	3.2 ± 0.4	17 70 000 4003
	4.0 ± 0.4	17 70 000 4004
19 positions	1.6 ± 0.4	17 70 000 5001
	2.4 ± 0.4	17 70 000 5002
	3.2 ± 0.4	17 70 000 5003
	4.0 ± 0.4	17 70 000 5004

Dimensions

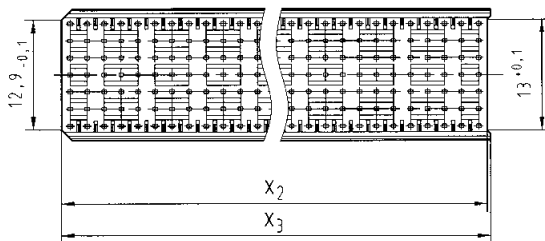
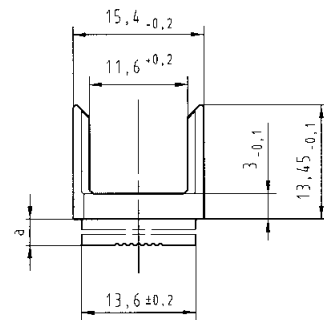
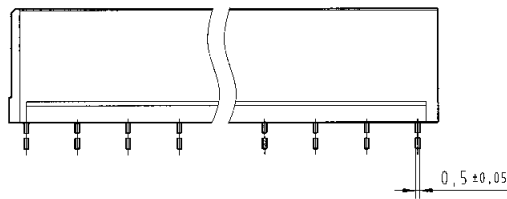
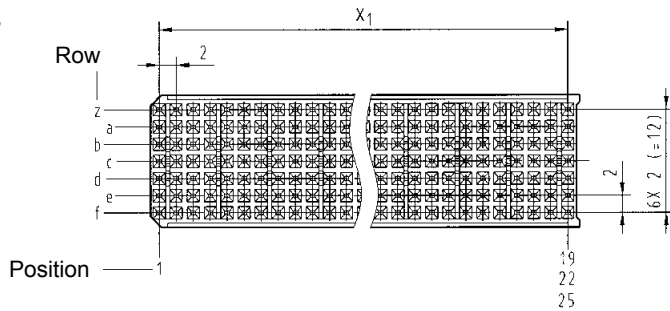

Board thickness [mm]	a [mm]
1.6 ± 0.4	3.1 ± 0.05
2.4 ± 0.4	2.3 ± 0.05
3.2 ± 0.4	1.5 ± 0.05
4.0 ± 0.4	0.7 ± 0.05

Contact positions	x ₁ [mm]	x ₂ [mm]	x ₃ [mm]
19	18 x 2 (= 36)	38 - 0.2	38.4 - 0.2
22	21 x 2 (= 42)	44 - 0.2	44.4 - 0.2
25	24 x 2 (= 48)	50 - 0.2	50.4 - 0.2

Dimensions [mm]



Identification	Board thickness [mm]	Part number
Type AB shroud 25 positions	1.6 ± 0.4	17 70 000 8001
	2.4 ± 0.4	17 70 000 8002
	3.2 ± 0.4	17 70 000 8003
	4.0 ± 0.4	17 70 000 8004
22 positions	1.6 ± 0.4	17 70 000 7001
	2.4 ± 0.4	17 70 000 7002
	3.2 ± 0.4	17 70 000 7003
	4.0 ± 0.4	17 70 000 7004
19 positions	1.6 ± 0.4	17 70 000 6001
	2.4 ± 0.4	17 70 000 6002
	3.2 ± 0.4	17 70 000 6003
	4.0 ± 0.4	17 70 000 6004

Dimensions

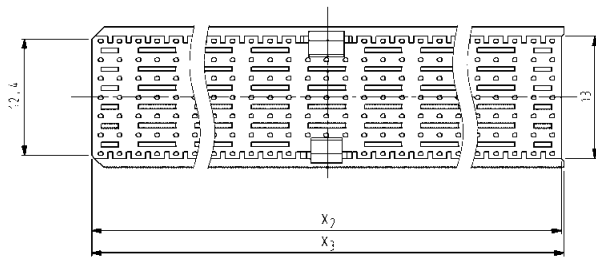
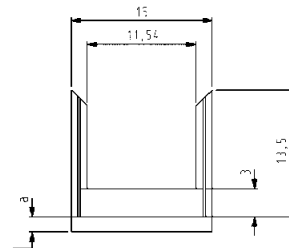
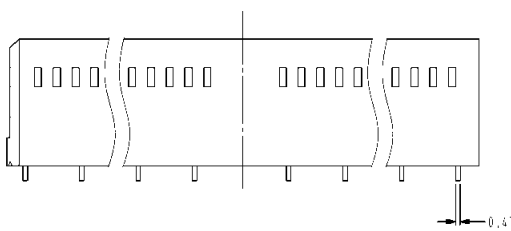
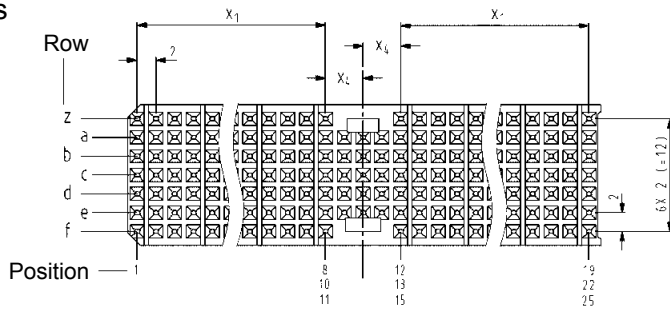

Board thickness [mm]	a [mm]
1.6 ± 0.4	3.1 ± 0.05
2.4 ± 0.4	2.3 ± 0.05
3.2 ± 0.4	1.5 ± 0.05
4.0 ± 0.4	0.7 ± 0.05

Contact positions	x ₁ [mm]	x ₂ [mm]	x ₃ [mm]	x ₄ [mm]
19	7 x 2 (= 14)	37.9	38.2	4
22	8 x 2 (= 16)	43.9	44.2	3
25	10 x 2 (= 20)	49.9	50.2	4

Dimensions [mm]



Identification	Board thickness [mm]	Part number
Type C shroud 11 positions	1.6 ± 0.4	17 70 000 3001
	2.4 ± 0.4	17 70 000 3002
	3.2 ± 0.4	17 70 000 3003
	4.0 ± 0.4	17 70 000 3004

Dimensions

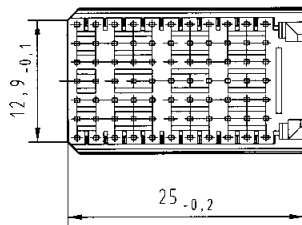
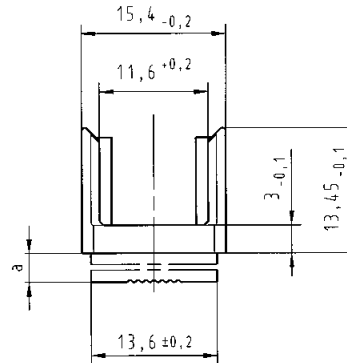
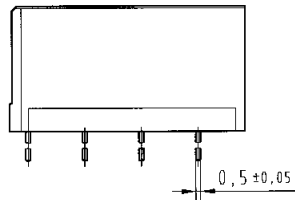
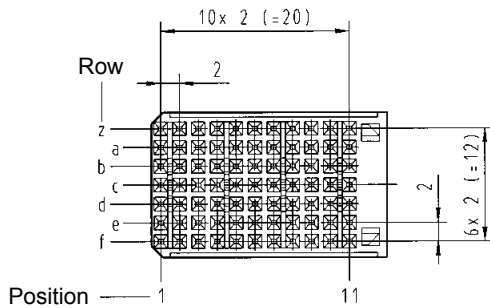

Board thickness [mm]	a [mm]
1.6 ± 0.4	3.1 ± 0.05
2.4 ± 0.4	2.3 ± 0.05
3.2 ± 0.4	1.5 ± 0.05
4.0 ± 0.4	0.7 ± 0.05

HARTING customer request form*

Should you need a specially loaded connector for your application, please use this request form. Fill out the drawing for the desired connector style and mark each position with the required contact length (A, B, ..., S, T).

Type A

Contact dimensions [mm]

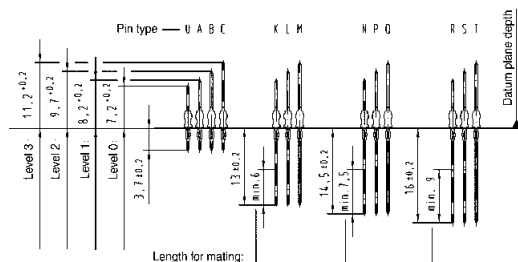

Type B (19, 22 or 25 positions)

Type C

Type Monoblock 47

Name: _____

Performance level: 1 2

Company: _____

Drawing: yes no

Address: _____

Samples: no yes, quantity

Volume (pcs./year): _____

Phone: _____

Fax: _____

Special requirements: _____

E-Mail: _____

* For AB types see page 11.49
For D, E and DE types see page 11.50

HARTING customer request form

Should you need a specially loaded connector for your application, please use this request form. Fill out the drawing for the desired connector style and mark each position with the required contact length (A, B, ..., S, T).

Type AB (19 positions)

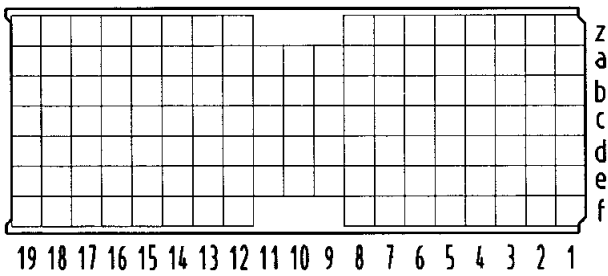

Contact dimensions [mm]

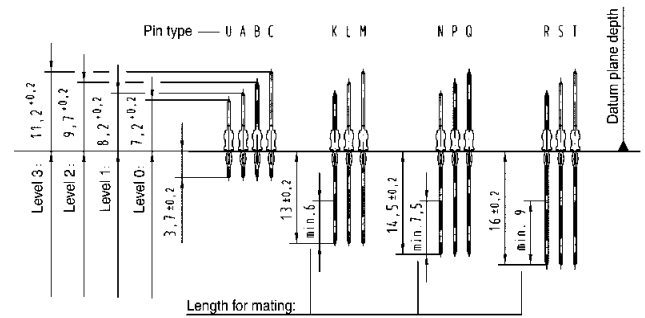

Type AB (22 positions)

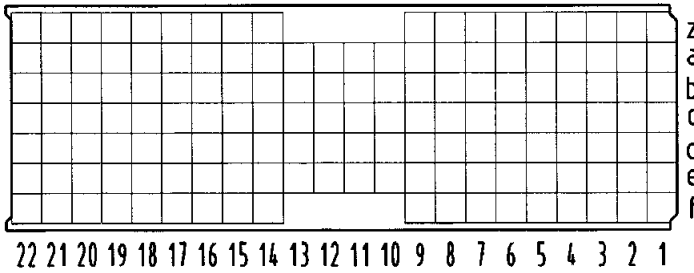

Type AB (25 positions)

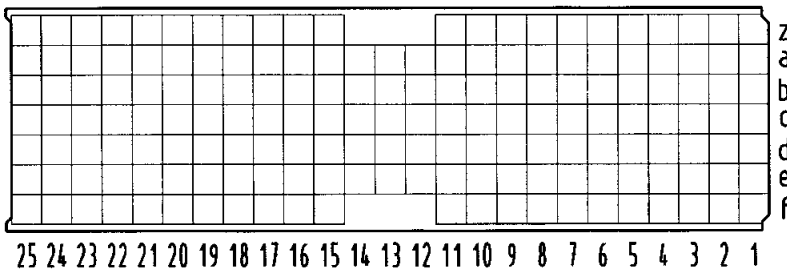

Name: _____

Performance level: 1 2

Company: _____

Drawing: yes no

Address: _____

Samples: no yes, quantity

Volume (pcs./year): _____

Phone: _____

Fax: _____

Special requirements: _____

E-Mail: _____

HARTING customer request form

Should you need a specially loaded connector for your application, please use this request form. Fill out the drawing for the desired connector style and mark each position with the required contact length (A, B, ..., S, T).

Type D

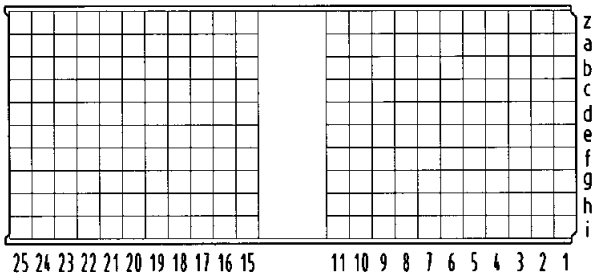

Contact dimensions [mm]

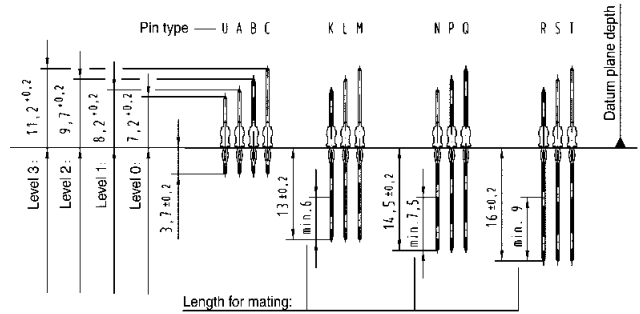

Type E

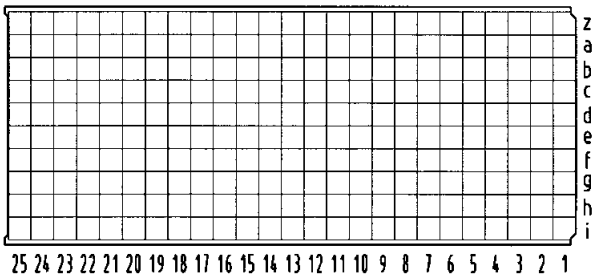

Type DE

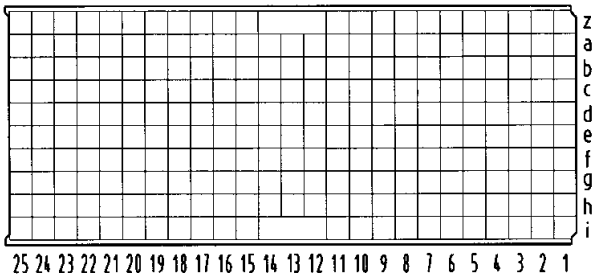

Name: _____

Company: _____

Address: _____

Phone: _____

Fax: _____

E-Mail: _____

Performance level: 1 2

Drawing: yes no

Samples: no yes, quantity

Volume (pcs./year): _____

Special requirements: _____

12. TCA Connectors

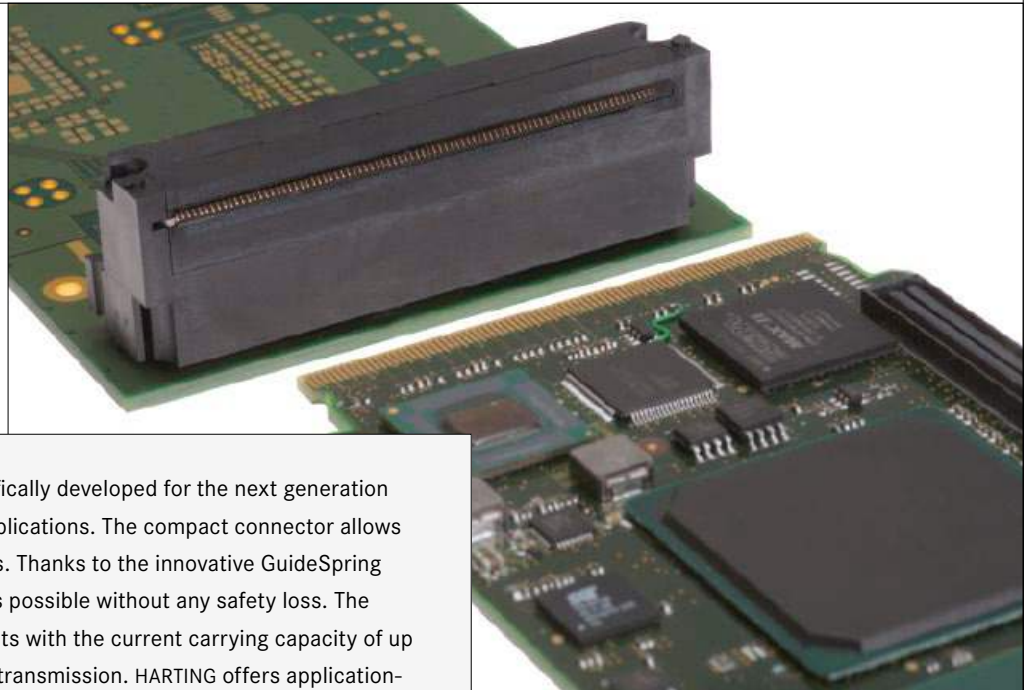

The TCA connectors have been specifically developed for the next generation of telecom, medical and industrial applications. The compact connector allows the transmission of highest data rates. Thanks to the innovative GuideSpring concept, the direct plug-in of a PCB is possible without any safety loss. The power connector offers power contacts with the current carrying capacity of up to 16 A as well as contacts for signal transmission. HARTING offers application-specific design-in support for the connectors, as well as the system analysis support.

Application profile:

CONNECTION TYPE		ENVIRONMENT		APPLICATION						
Board to Board	Cable/Wire to Board	IP20	IP65 / IP67	Data	Signal	Power	high performance			
							Data transfer rate	Shielding	Number of contacts, contact density	Voltage, working current
Cable termination			PCB termination			Application standard				
<i>Han-Quick Lock®</i> 	<i>IDC</i> 	<i>Crimp</i> 	<i>THT</i> 	<i>SMC</i> 	<i>SMT</i> 		AdvancedTCA® AdvancedMC™ μTCA™			
<i>Screw</i> 	<i>Cage clamp</i> 	<i>Axial screw</i> 	<i>Press-in</i> 	Housing integration						
						<i>Separate housing</i> 		<i>Integrated housing</i> 		

Contents

Page

Introduction	12.02
General information	12.04
	12.06
AdvancedMC™ connectors for AdvancedTCA®	12.08
Power connectors for AdvancedTCA®	12.10
AdvancedMC™ connectors for MicroTCA™	12.12
Power output connectors for MicroTCA™	12.14

CONNECTORS FOR TCA

The TCA connectors have been developed for the open hardware standards AdvancedTCA®, AdvancedMC™ and MicroTCA™. They are specified by the PCI Industrial Computer Manufacturers Group (PICMG), a consortium of more than 450 product suppliers. These innovative systems are finding increasing use for industrial control systems and computer systems. HARTING is an active member of the PICMG and participated in the standardization process of the connectors for these systems. HARTING offers several connectors for signal and power transmission. With the new “**con:card+**” connectors with press-in termination, HARTING has substantially improved the contact reliability of the

AdvancedMC™ connector for MicroTCA™ and AdvancedTCA®. The key element of the new “**con:card+**” connector is the integrated GuideSpring, which is able to compensate any tolerance deviations of the AdvancedMC™ printed circuit boards by centrally positioning the circuit board within the connector slot. The GuideSpring allows HARTING to ensure the reliable connection of the circuit boards, which can be manufactured in large-scale production today. Other advantages of the “**con:card+**” technology are the extremely smooth contact surface and a robust contact coating which allows the specified 200 mating cycles between the daughter card and the card edge connector.

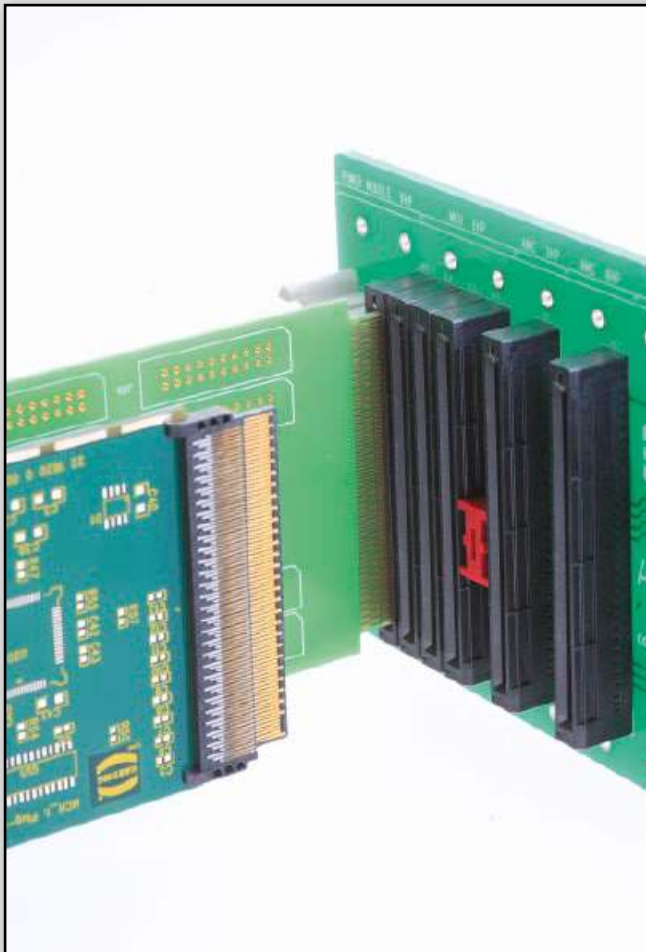

HIGH CONTACT RELIABILITY

The "con:card+" technology offers highest contact reliability as required for industry applications.

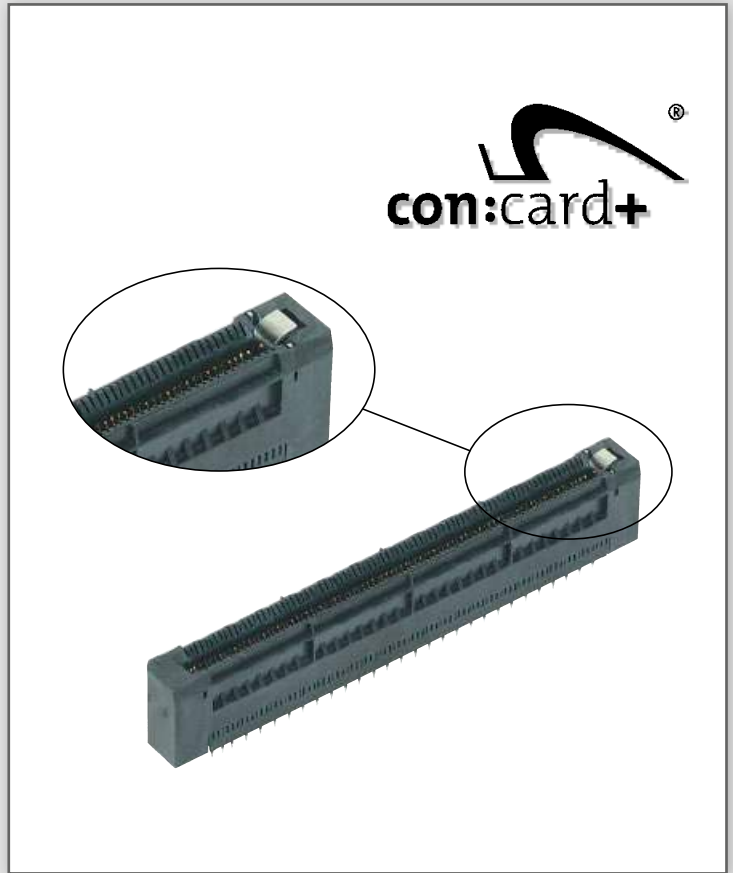

INTERNATIONAL STANDARD

The TCA connectors meet the requirements of the PICMG (PCI Industrial Computers Manufacturers Group) specifications AdvancedMC™, Advanced TCA® and MicroTCA™ and can be used for these applications.

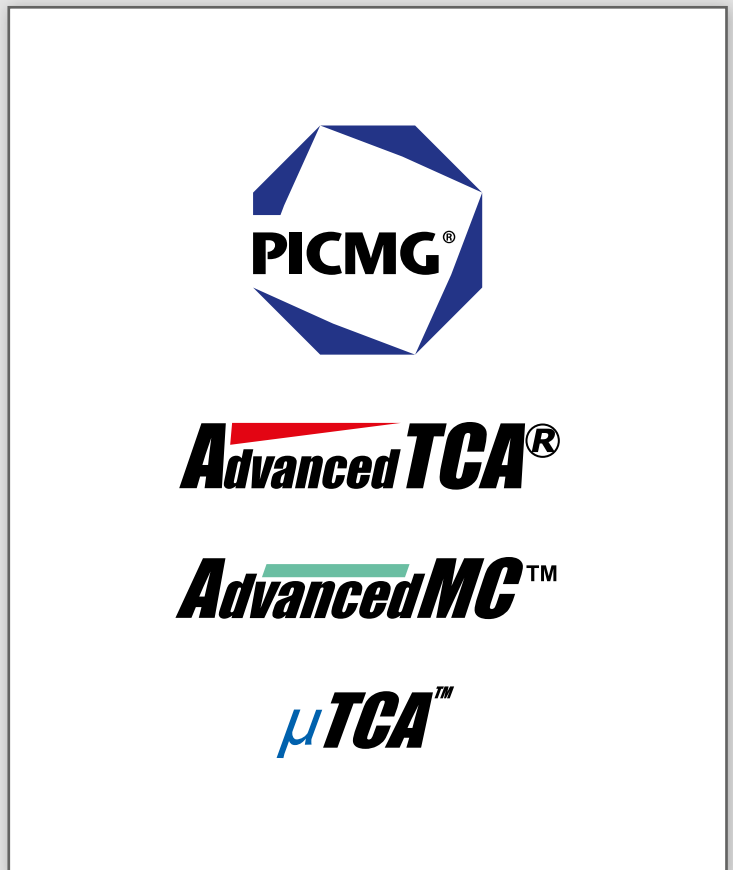



PICMG, formally known as the PCI Industrial Computing Manufacturing Group – is an industry consortium of over 450 companies. PICMG's purpose is to define standard architectures in an effort to reduce system costs

and development cycles and since its 1994 foundation, PICMG has been responsible for the establishment of several of successfully implemented, open, industrial standards. Open standards have proven themselves to be very advantageous for system manufacturers and end-user, because they create multiple vendors of similar parts, low prices at high volumes, and a shortened time-to-market.

Historically, PICMG has created several successful standards.

- PICMG 1.x Series – a passive backplane PCI specification
- PICMG 2.x Series – the CompactPCI® standard

AdvancedTCA®

Today, the AdvancedTCA® series of specifications (PICMG 3.x) targets the requirements of the next generation of carrier grade telecommunications equipment. AdvancedTCA®, short for Advanced Telecom Computing Architecture and sometimes simply abbreviated ATCA®, incorporates an impressive suite of recent technological advancements including the latest trends in high speed interconnect technologies.

Features of AdvancedTCA® include optimization for high-capacity, high-performance telecom and industrial applications, improved reliability, manageability, redundancy, and serviceability. Encompassing a technological growth path valid for up to ten years, AdvancedTCA® has earned a solid position within the telecom systems market.



AdvancedTCA® chassis with backplane

The rack or chassis, is responsible for housing the backplane and the daughtercards, as well as cooling and powering the system. HARTING offers the ATCA® power connector that energises the blades, both the straight backplane and the right angled daughtercard connector.

The backplane, said to be passive, is merely a medium for the daughtercards to communicate with each other. And, the daughtercards, sometimes called blades or boards, provide the system with its functionality and allow for an easy, hot-swappable module exchange from the front of the system.

Initially, many blades were designed with a fixed functionality, and they had to be replaced once their functionality became obsolete or the demands of the system changed. With the continuation of exponential technological growth, concept proved to be a costly endeavour for the end-user.

AdvancedMC™

To extend the functionality and modularity of AdvancedTCA®, blade manufacturers conceived the idea of upgradeable daughtercards, and began to insert mezzanine cards onto the blades when needed. To achieve a common mezzanine concept, PICMG developed the Advanced Mezzanine Card (AdvancedMC™) standard AMC.0.



AdvancedMC™ modules for different applications

For the use of Advanced Mezzanine Cards, as well called AdvancedMC™ modules, a carrier is necessary. A carrier is an ATCA® blade with only little functionality beyond AdvancedMC™ management. It contains the mechanical environment for the AdvancedMC™ modules. Depending on their size, up to eight AdvancedMC™ modules can be hot-swapped in and out of a carrier, this enabled the



AdvancedTCA[®] carrier board with AdvancedMC[™] modules

creation of extremely scalable and upgradeable systems.

To connect AdvancedMC[™] modules to carrier boards PICMG defined a new high-speed mezzanine connector: the AdvancedMC[™] connector – a card edge connector mounted on the carrier board. It contacts directly with the module's PCB gold pads. Although PICMG defined four AdvancedMC[™] connector types (B, B+, AB and A+B+), current market developments focus on type B+.

The HARTING AdvancedMC[™] B+ connector features a new design element that supplements the standard – the GuideSpring. The GuideSpring significantly increases the mating reliability and prevents contact interruptions and surface wear when subjected to shocks or vibrations.

The press-fit termination technology provides significant cost and durability advantages over other termination technologies. The connector design allows for the use of a standard flat rock die. For more press-in process control, HARTING offers a special top and bottom tool.

μTCA[™]

This revolutionary AdvancedMC[™]-based design concept has led to the recent development of a completely mezzanine-based system – MicroTCA[™]. MicroTCA[™], short for Micro Telecom Computing Architecture, is a more cost-efficient platform than AdvancedTCA[®] when dealing with smaller applications, yet powerful enough to address the needs of telecom, enterprise and medical applications.

This newly-implemented PICMG standard, outlined in the MTCA.0 specification, presents a design-concept whereby AdvancedMC[™]s – the same kind used in ATCA[®] systems – plug directly into a passive backplane; this eliminates the need for carrier boards.



MicroTCA[™] double cube system

Naturally the mating face of the AdvancedMC[™] connector for MicroTCA[™] is the same as for ATCA[®], but with a right angled mating direction. It contains the new GuideSpring and is available in press-in termination. PICMG members voted HARTING's MicroTCA[™] connector footprint as the new MicroTCA[™] standard connector for press-fit termination technology.

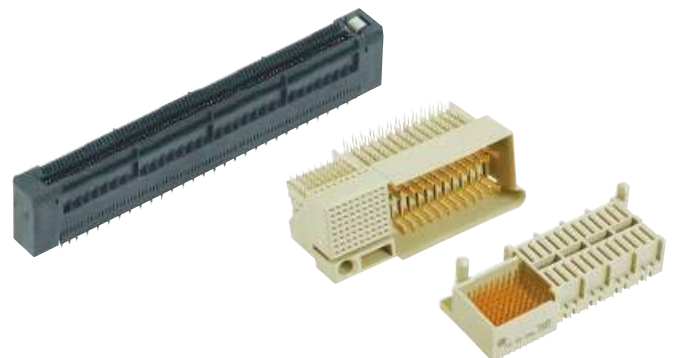

AdvancedMC[™] and power connectors for MicroTCA[™]

The MicroTCA[™] backplane is typically powered by special, field replaceable, hot-swappable, redundant Power Supply Units (PSU). The PSU connects to the backplane through a MicroTCA[™] power connector (press-fit termination) also available from HARTING.

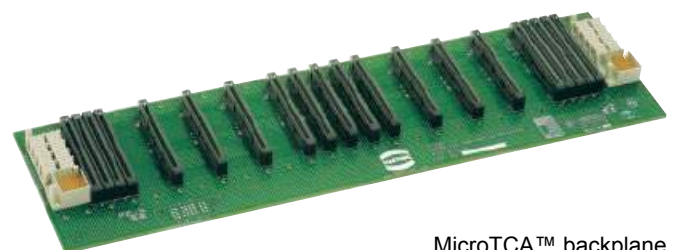

MicroTCA[™] backplane

The module management is performed by a MicroTCA[™] Carrier Hub, or MCH. An MCH is connected to the backplane by up to four adjacent card-edge connectors. One MCH can control up to 12 AdvancedMC[™] modules, thus depending on redundancy requirements, workload, or both, one or two MCHs may be used within a single system.

What is con:card+?

con:card+ is a quality seal for AdvancedMC™ connectors that helps to deliver a significant increase in the reliability of MicroTCA™ and AdvancedTCA® systems. In order to reach the target availability of 99.999 %, all system components must be carefully coordinated, and they must function reliably. The

selection of suitable connectors is an essential, decisive factor here, as today it is virtually impossible for series production to meet the strict tolerances for the AdvancedMC™ modules as defined in the respective specifications. The so-called GuideSpring is ideally suited for compensating here, and represents just one of a total of five key advantages of the con:card+ philosophy. All the advantages are introduced in the following. Please find further information also on the internet at www.concardplus.com.



Special contact design

Unlike conventional mating systems with male and female connectors, the AdvancedMC™ has only one, not two, contact tongues per contact. In order to ensure a permanently reliable contact, this single contact tongue must press against the gold pad with sufficient force throughout the entire lifetime. In addition, the thickness of the AdvancedMC™ modules may fluctuate by $\pm 10\%$. To meet this challenge, HARTING utilizes a special contact design with very low relaxation for the con:card+ connector.



PdNi contact coating

In order better to meet the high requirements placed on the connectors, a palladium-nickel surface (PdNi) with additional gold flash is used. As a result, wear resistance is increased by roughly 30 %. Even when applied very thinly, PdNi surfaces offer a quality and corrosion-resistant coating that meets the high requirements placed on the connection far better than pure gold.





Smooth contact surface

The specification for the AdvancedMC™ entails 200 mating cycles for a module. On the PCB, the nickel/hard gold layer on the relatively soft copper can only stand up to this high load if the contact surface is absolutely smooth.

This is the case with the **con:card+** connector. With years of experience in stamping techniques and the utilization of high-performance stamping tools with special process components, HARTING is actively involved in minimizing gold pad wear.

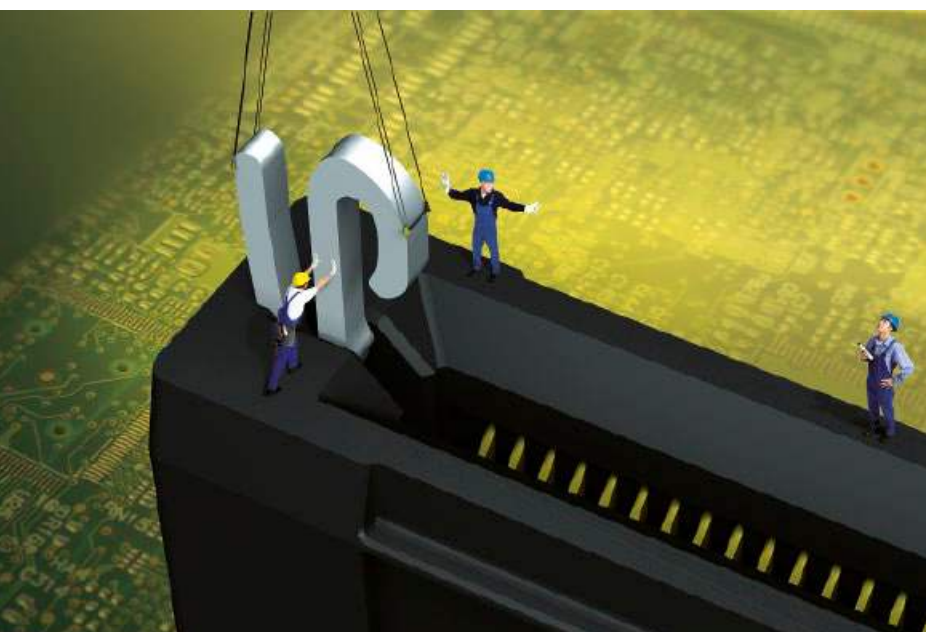

GuideSpring

PCB manufacturers are not capable of meeting the AdvancedMC™ modules' tight tolerances with certainty in the series process today. Just a single card with tolerances slightly larger than allowed by the specifications can lead to a system breakdown.

The **con:card+** GuideSpring offsets these tolerance deviations by constantly pressing the module against the opposite wall. As this is displaced somewhat towards the middle, the slot is optimally designed for the AdvancedMC™ module, and the mating reliability increases tremendously.

In addition, the GuideSpring secures the module position in the case of shocks and vibrations. This prevents loss of contact and surface wear.

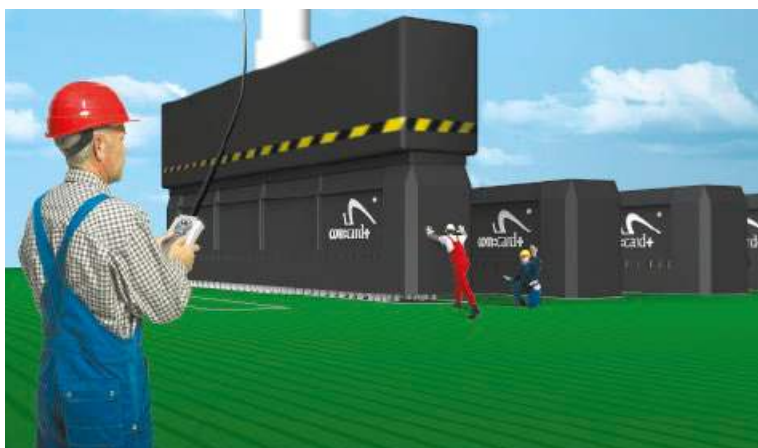

Press-fit technology

Press-fit technology results in a gas-tight, corrosion-resistant, low-ohm quality mechanical connection between the pin and the through contacting of the PCB. This remains reliably in contact and stable, even under conditions of high mechanical and thermal loads, such as vibration, bending and frequent temperature changes. This technology represents a tremendous advantage over other processing techniques. Measurements substantiate that the required transmission rates are easily attained.

Technical characteristics

Design according	PICMG AMC.0 (RoHS compliance)
Number of contacts	170
Contact spacing	0.75 mm
Clearance and creepage distance between contacts	0.1 mm min.
Working current of power contacts as defined in AMC.0 spec.	~ 2.2 A @ 70 °C max. 30 °C temp. rise (PICMG requirement min. 1.52 A)
Test voltage	80 V _{r.m.s.}
Working voltage typically	3.3 V; 5.0 V; 12.0 V
Initial contact resistance ground contacts	60 mΩ max.
signal, power, general purpose contacts	90 mΩ max.
Initial insulation resistance	100 MΩ min.

Nominal differential impedance	100 Ω±10 %
--------------------------------	------------

Max. crosstalk @ 25 ps risetime	Bottom route
Adjacent	0.55 %
Basic-to-extended (diagonal)	0.68 %
Basic-to-extended (opposite)	0.39 %
Multiline (five multi-aggressor differential pairs)	2.74 % max.

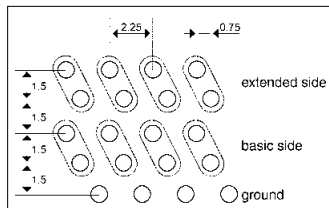

PCB library on request (PADS/Dx-Designer)
SPICE models and S-Parameter on request

Differential propagation delay	Basic side: 125 ps Extended side: 145 ps
Differential skew	Between basic and extended side: 20 ps Within basic and extended side: ±2 ps

Temperature range	-55 °C ... +105 °C
Durability as per AMC.0 specification	200 mating cycles

Termination technique	Press-in termination
Mating force	100 N max., typically 65 - 90 N (depending on AdvancedMC™)
Withdrawal force	65 N max., typically 30 - 45 N (depending on AdvancedMC™)

Materials	
Moulded parts	Liquid Crystal Polymer (LCP), UL 94-V0
Contacts	Copper Alloy
Contact surface	Pd/Ni with Au flash
Packaging	Cardboard box (other packaging on request)

Recommended plated through hole specification			
	A	Drill hole-Ø	0.64±0.01 mm
	B	Cu	25 - 35 µm
Tin plated PCB (HAL)	C	Sn	5 - 15 µm
	D	Hole-Ø	0.53 - 0.60 mm
Au / Ni plated PCB	C	Ni	3 - 7 µm
		Au	0.05 - 0.12 µm
	D	Hole-Ø	0.55 - 0.60 mm
	Chemical tin plated PCB	C	Sn
D		Hole-Ø	0.56 - 0.60 mm
OSP copper plated PCB	C	---	---
	D	Hole-Ø	0.56 - 0.60 mm
E	Pad size	min. 0.95 mm	

The press-in zone of the AdvancedMC™ connector is tested according to Telcordia/Bellcore GR 1217CORE Part7. It is approved to be used with a plated through hole according to IEC 60352-5 with a diameter of 0.55±0.05 mm (drilled hole 0.64±0.01 mm).
Based on our experiences regarding the production process of the PCB manufacturer we recommend a plated through hole configuration like shown in the above spreadsheet. To achieve the recommended plated through hole diameter, it is important to specify especially the drilled hole diameter of 0.64±0.01 mm to your PCB supplier.
For drillings use e.g. drill bit # 72 (0.025" ≈ 0.64 mm).

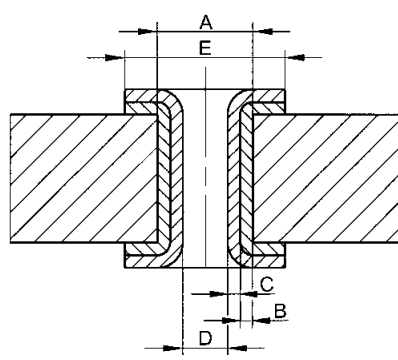

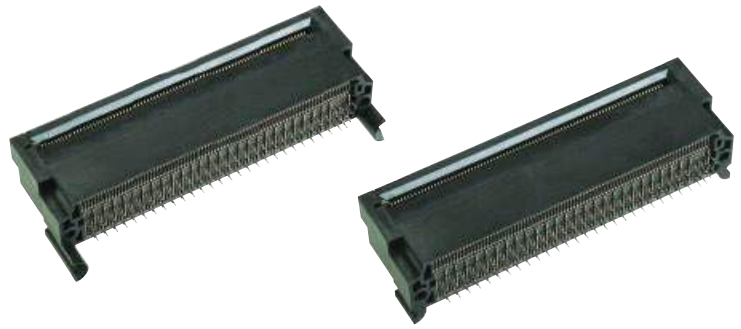

Card edge connectors, angled

Identification	No. of contacts	Contact length [mm] termination side	Part number
AdvancedMC™ connector for ATCA®, type B+ with peg and with GuideSpring	170	2.0	16 04 170 5104 000
AdvancedMC™ connector for ATCA®, type B+ without peg and with GuideSpring	170	2.0	16 04 170 5106 000

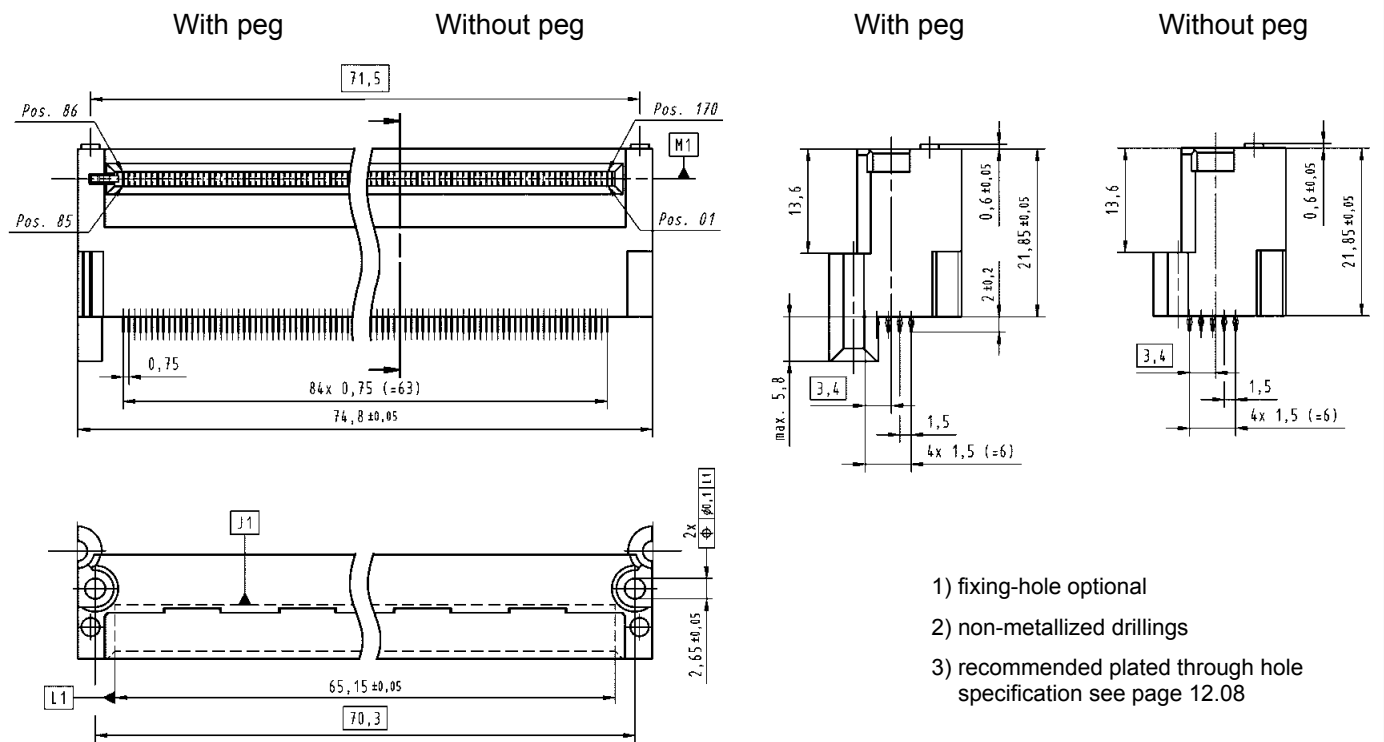

- 1) fixing-hole optional
- 2) non-metallized drillings
- 3) recommended plated through hole specification see page 12.08

Board drillings (view magnified)

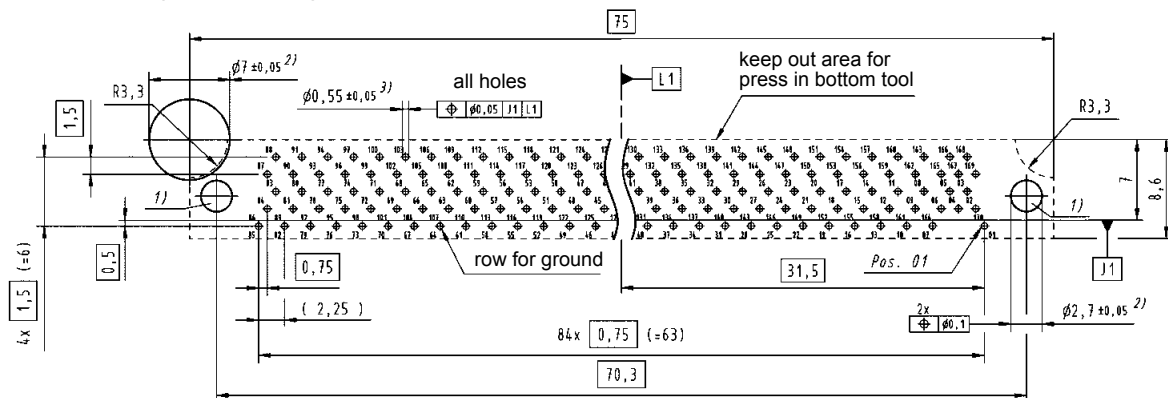

Dimensions [mm]

Technical characteristics

Design according	PICMG 3.0 R2.0
Total number of contacts	30, max. 34
Power contacts	8
Signal contacts	22, max. 26
Clearance and creepage distance between contacts	
Within group 5–16	0.7 mm min.
Within group 17–24	2.5 mm min.
25 to 26	5.5 mm min.
Within group 27–34	1.4 mm min.
13–16 to 17–20	3.0 mm min.
21–24 to 25–26	4.0 mm min.
25–26 to 27–29	2.0 mm min.
Sequential contact engagement	
1st	25, 26, 28, 29, 30, 31
2nd	33
3rd	5–24, 34
4th	27, 32
Working current	
Power contacts	16 A
Signal contacts	1 A
Test voltage	
Contacts 1–16	1000 V _{r.m.s.}
Contacts 17–34	2000 V _{r.m.s.}
Initial contact resistance	
Power contacts	≤ 2.2 mΩ
Signal contacts	≤ 8.5 mΩ
Insulation resistance	≥ 10 ¹⁰ Ω
Temperature range	-55 °C ... +125 °C
Durability	250 mating cycles
Termination technique	Press-in termination
Mating force	67 N max.
Withdrawal force	67 N max.

Derating for ATCA® power contacts

Contact loading acc. PICMG 3.0

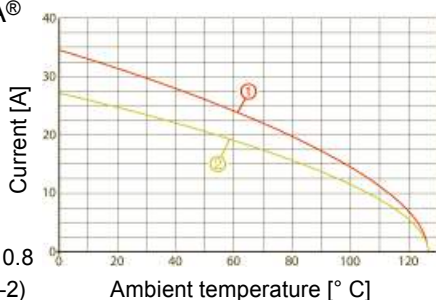

- ① Derating
- ② Derating @ I_{max.} x 0.8 (acc. IEC 60512-5-2)

Materials

Moulded parts	PBT, glass-fibre filled, UL 94-V0
Contacts	Copper Alloy
Contact surface	Selectively gold plated

Packaging	Cardboard box (other packaging on request)
-----------	--

Recommended plated through hole specification

		Signal contacts	Power contacts
	A Drill hole-Ø	1.15±0.025 mm	1.75±0.025 mm
	B Cu	25 - 35 µm	25 - 35 µm
Tin plated PCB (HAL)	C Sn	5 - 15 µm	5 - 15 µm
	D Hole-Ø	1.00 - 1.10 mm	1.60 - 1.70 mm
Au / Ni plated PCB	C Ni	3 - 7 µm	3 - 7 µm
	Au	0.05 - 0.12 µm	0.05 - 0.12 µm
	D Hole-Ø	1.00 - 1.10 mm	1.60 - 1.70 mm
Chemical tin plated PCB	C Sn	0.8 - 1.5 µm	0.8 - 1.5 µm
	D Hole-Ø	1.00 - 1.10 mm	1.60 - 1.70 mm
Silver plated PCB	C Ag	0.1 - 0.3 µm	0.1 - 0.3 µm
	D Hole-Ø	1.00 - 1.10 mm	1.60 - 1.70 mm
OSP copper plated PCB	C ---	---	---
	D Hole-Ø	1.00 - 1.10 mm	1.60 - 1.70 mm
	E Pad size	min. 1.4 mm	min. 2.0 mm

The press-in zone of the AdvancedTCA® power connector is tested according to Telcordia/Bellcore GR 1217CORE Part7. It is approved to be used with a plated through hole according IEC 60352-5 with a diameter of 1.00^{+0.09}_{-0.06} mm for signal contacts and 1.60^{+0.09}_{-0.06} mm for power contacts (drilled hole 1.15±0.025 mm resp. 1.75±0.025 mm).

Based on our experiences regarding the production process of the PCB manufacturer we recommend a plated through hole configuration like shown in the above spreadsheet. To achieve the recommended plated through hole diameter, it is important to specify especially the drilled hole diameter of 1.15±0.025 mm resp. 1.75±0.025 mm to your PCB supplier.

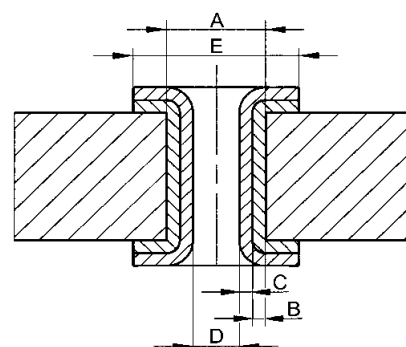

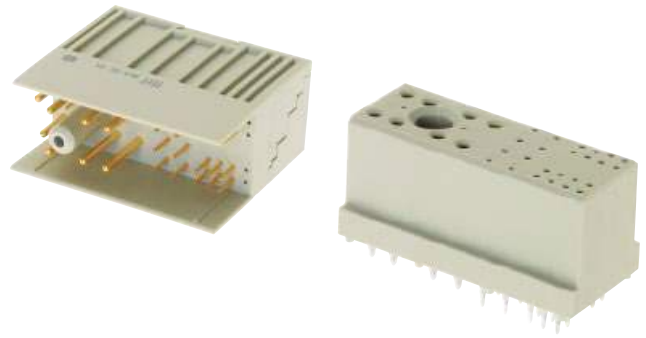

Identification	No. of contacts	Contact length [mm] termination side	Part number
Power connector for AdvancedTCA®, male	30	4.1	16 32 030 1101 000
	34	4.1	16 32 034 1101 000
Power connector for AdvancedTCA®, female	30	5.3	16 31 030 1201 000
	34	5.3	16 31 034 1201 000

Male connector with 30 contacts

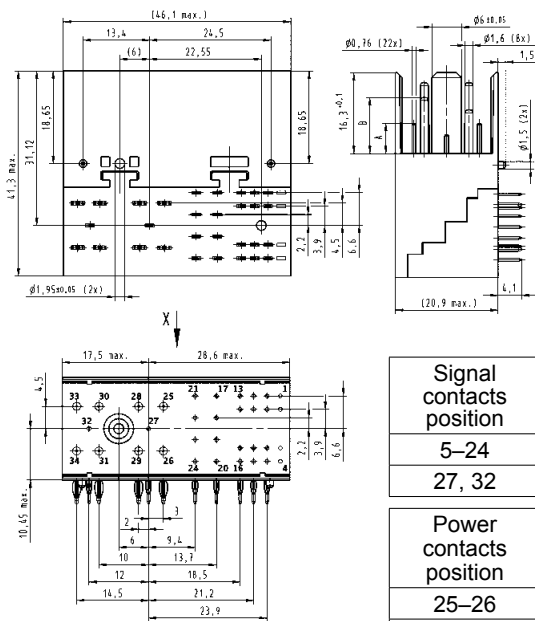

Female connector with 30 contacts

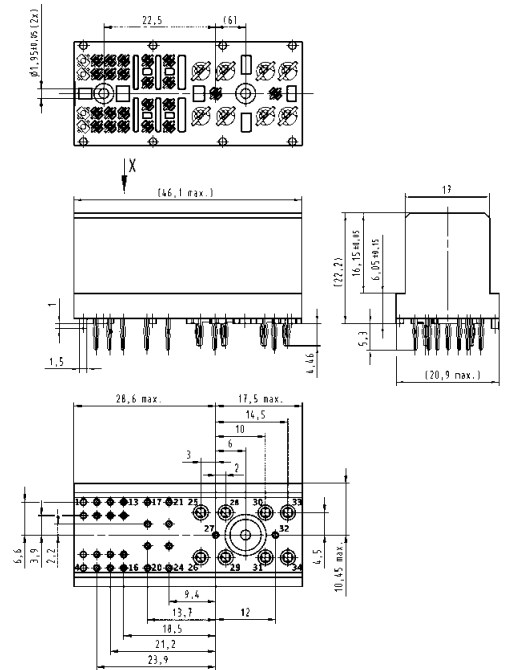

Signal contacts position	Dimension A
5–24	6.1
27, 32	3.8

Power contacts position	Dimension B
25–26	14.3
28–31	14.3
33	11.3
34	8.8

Board drillings

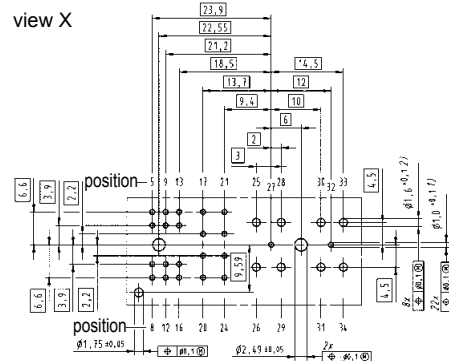
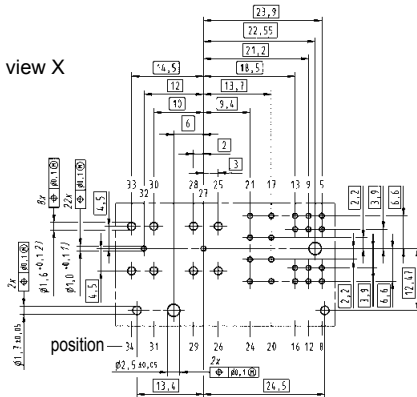

1) + 2) recommended plated through hole specification see page 12.10

Dimensions [mm]

Technical characteristics

Design according	PICMG MTCA.0 R1.0 (RoHS compliance)
Number of contacts	170
Contact spacing	0.75 mm
Clearance and creepage distance between contacts	0.1 mm min.
Working current of power contacts as defined in MTCA.0 spec.	~ 2.3 A @ 70 °C max. 30 °C temp. rise (PICMG requirement min. 1.52 A)
Test voltage	80 V _{r.m.s.}
Working voltage typically	3.3 V; 5.0 V; 12.0 V
Initial contact resistance	25 mΩ max.
Initial insulation resistance	100 MΩ min.

Nominal differential impedance	100 Ω±10 %
--------------------------------	------------

Max. NEXT @ 25 ps risetime	Bottom route
Adjacent	0.65 %
Basic-to-extended (diagonal)	0.60 %
Basic-to-extended (opposite)	0.73 %
Multiline (five multi-aggressor differential pairs)	2.88 % max.

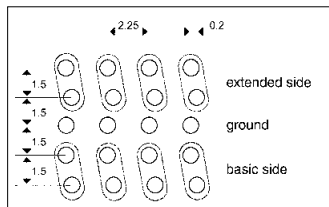

PCB library on request
(PADS/Dx-Designer)

SPICE models and
S-Parameter on request

Differential propagation delay	Basic side: 70 ps ± 5 ps Extended side: 70 ps ± 5 ps
Differential skew	Between basic and extended side: ±2 ps Within basic and extended side: ±2 ps

Temperature range	-55 °C ... +105 °C
Durability as per MTCA.0 spec.	200 mating cycles
Termination technique	Press-in termination
Mating force	100 N max., typically 60 - 80 N (depending on AdvancedMC™)
Withdrawal force	65 N max., typically 40 - 60 N (depending on AdvancedMC™)

Materials	
Moulded parts	Liquid Crystal Polymer (LCP), UL 94-V0
Contacts	Copper Alloy
Contact surface	Pd/Ni with Au flash Au over Ni on request
Packaging	Cardboard box (other packaging on request)

Recommended plated through hole specification

	A	Drill hole-Ø	0.64±0.01 mm
	B	Cu	25 - 35 µm
Tin plated PCB (HAL)	C	Sn	5 - 15 µm
	D	Hole-Ø	0.53 - 0.60 mm
Au / Ni plated PCB	C	Ni	3 - 7 µm
		Au	0.05 - 0.12 µm
	D	Hole-Ø	0.55 - 0.60 mm
Chemical tin plated PCB	C	Sn	0.8 - 1.5 µm
	D	Hole-Ø	0.56 - 0.60 mm
OSP copper plated PCB	C	---	---
	D	Hole-Ø	0.56 - 0.60 mm
	E	Pad size	min. 0.95 mm

The press-in zone of the AdvancedMC™ connector is tested according to Telcordia/Bellcore GR 1217CORE Part7. It is approved to be used with a plated through hole according IEC 60352-5 with a diameter of 0.55±0.05 mm (drilled hole 0.64±0.01 mm). Based on our experiences regarding the production process of the PCB manufacturer we recommend a plated through hole configuration like shown in the above spreadsheet. To achieve the recommended plated through hole diameter, it is important to specify especially the drilled hole diameter of 0.64±0.01 mm to your PCB supplier. For drillings use e.g. drill bit # 72 (0.025" ≈ 0.64 mm).

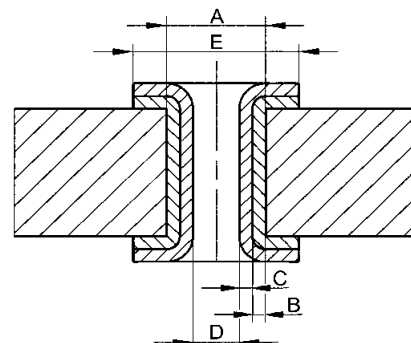

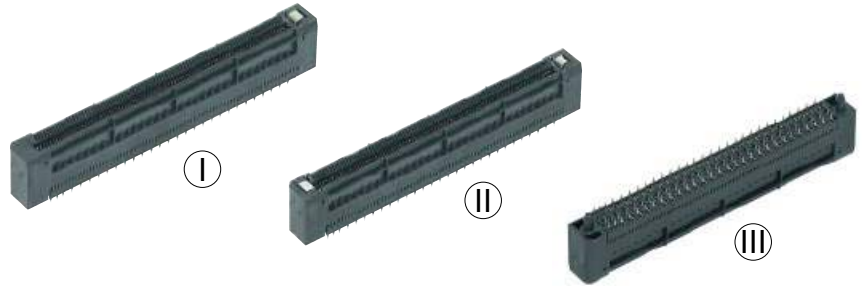

Card edge connectors, straight

Identification	No. of contacts	Contact length [mm] termination side	Part number
AdvancedMC™ connectors for MicroTCA™ with GuideSpring ①	170	2.1	16 11 170 5202 000
with GuideSpring and protection shield ②	170	2.1	16 11 170 5205 000
with GuideSpring and alignment peg ③	170	2.1	16 11 170 5206 000
with GuideSpring, protection shield and alignment peg	170	2.1	16 11 170 5207 000

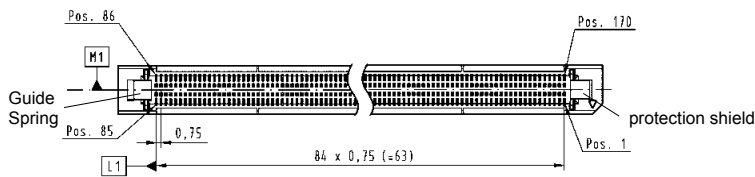
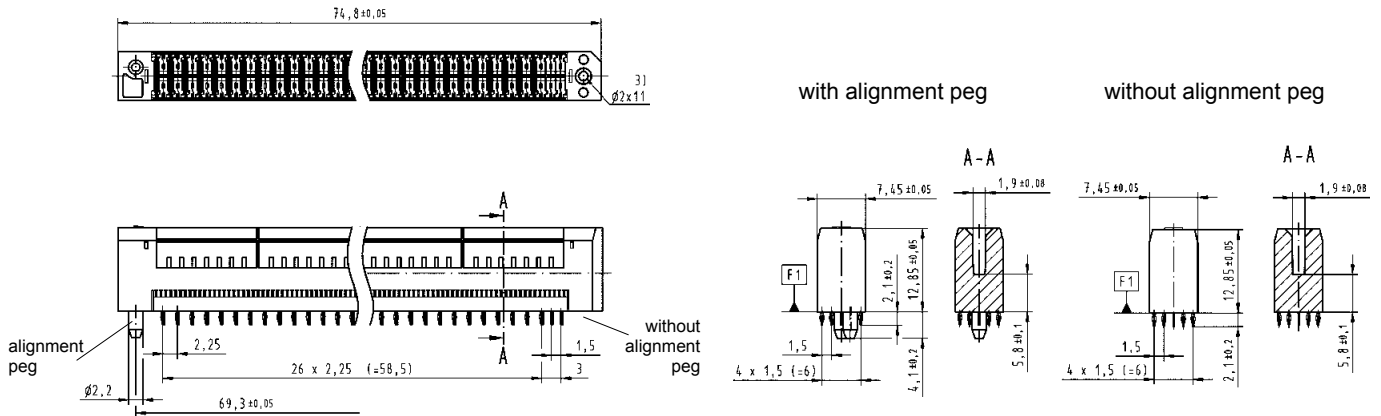

- 1) recommended plated through hole specification see page 12.12
- 2) non-metallized drillings
optional: for part numbers 16 11 170 5202 000 and 16 11 170 5205 000
mandatory: for part numbers 16 11 170 5206 000 and 16 11 170 5207 000
- 3) for optional fixing: use self-tapping screws for plastic, 2.2 x length (length = PCB thickness + min. 6.5 mm to max. 10 mm)
e.g. HARTING part number 09 06 001 9974
Screwing torque references:
PCB + 6.5 mm: 20 cNm
PCB + 10 mm: 40 cNm

Board drillings (view magnified)

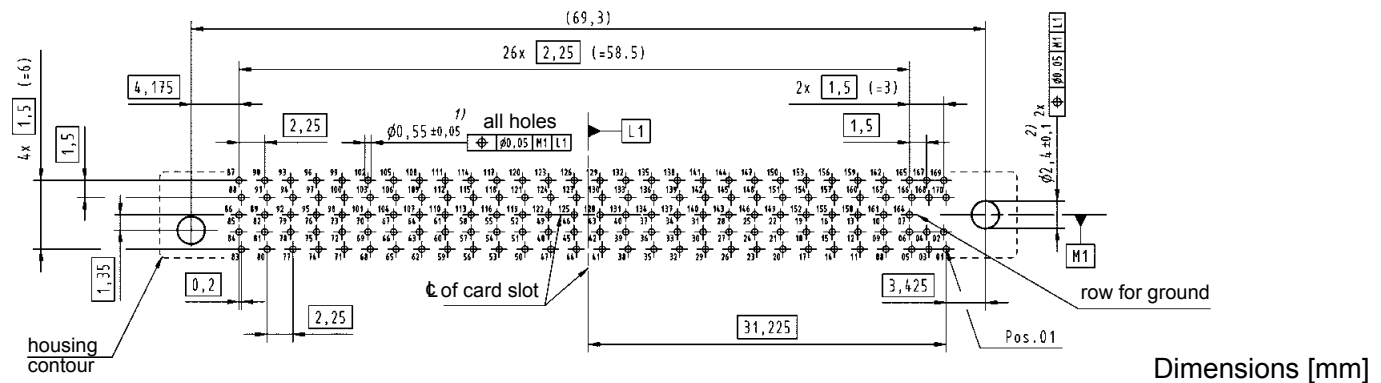

Technical characteristics

Design according to PICMG MTCA.0 R1.0 (RoHS compliance)

Total number of contacts: 96
 Power contacts: 24
 Signal contacts: 72

Sequential contact engagement:
 1st: Power 4–11
 2nd: Power 1–3, power 12–24
 3rd: Signal A2–H9
 4th: Signal A1

Working current:
 Power contacts: 9.3 A @ 80 % derating acc. IEC 60512 and 70 °C ambient temperature and 30 °C temperature rise
 Signal contacts: 1 A @ 80 % derating acc. IEC 60512 and 70 °C ambient temperature

Initial contact resistance:
 Power contacts: ≤ 5 mΩ
 Signal contacts: ≤ 25 mΩ

Initial insulation resistance: ≥ 100 MΩ min.

Temperature range: -55 °C ... +105 °C
 Durability: 200 mating cycles

Termination technique: Press-in termination
 Mating force: 145 N max.
 Withdrawal force: 110 N max.

Derating for MicroTCA™ power contacts
 Contact loading acc. MTCA.0

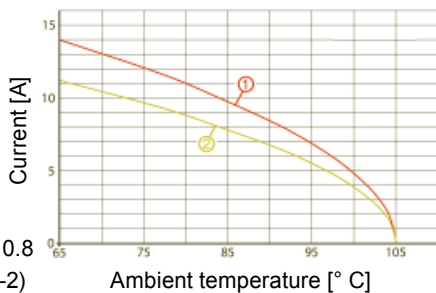

① Derating
 ② Derating @ $I_{max} \times 0.8$ (acc. IEC 60512-5-2)

Materials

Moulded parts: PBT, glass-fibre filled, UL 94-V0
 Contacts: Copper Alloy
 Contact surface:
 Power contacts: selectively gold plated
 Signal contacts: selectively PD/Ni plated

Packaging: Tray packaging (other packaging on request)

Recommended plated through hole specification

	A	Drill hole-Ø	0.7±0.02 mm
	B	Cu	25 - 35 µm
Tin plated PCB (HAL)	C	Sn	5 - 15 µm
	D	Hole-Ø	0.60 - 0.65 mm
Au / Ni plated PCB	C	Ni	3 - 7 µm
		Au	0.05 - 0.12 µm
Chemical tin plated PCB	D	Hole-Ø	0.60 - 0.65 mm
	C	Sn	0.8 - 1.5 µm
Silver plated PCB	D	Hole-Ø	0.60 - 0.65 mm
	C	Ag	0.1 - 0.3 µm
OSP copper plated PCB	D	Hole-Ø	0.60 - 0.65 mm
	C	---	---
	E	Pad size	min. 1.0 mm

The press-in zone of the MicroTCA™ power connector is tested according to Telcordia/Bellcore GR 1217CORE Part7. It is approved to be used with a plated through hole according IEC 60352-5 with a diameter of 0.60^{+0.05} mm (drilled hole 0.70±0.02 mm).

Based on our experiences regarding the production process of the PCB manufacturer we recommend a plated through hole configuration like shown in the above spreadsheet. To achieve the recommended plated through hole diameter, it is important to specify especially the drilled hole diameter of 0.70±0.02 mm to your PCB supplier.

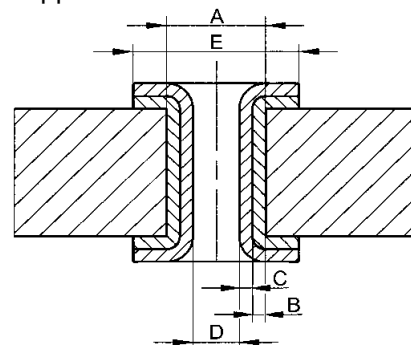

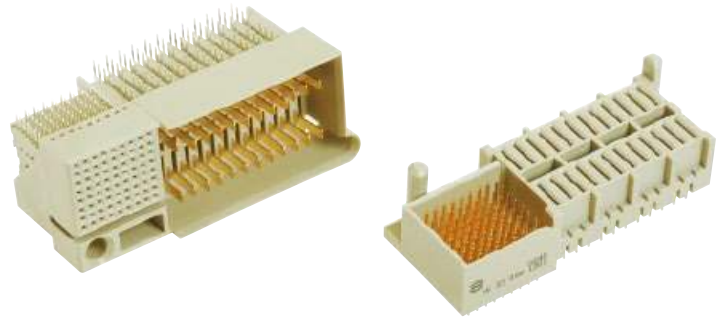

Identification	No. of contacts	Contact length [mm] termination side	Part number
Power output connectors for MicroTCA™			
module version	96	2.8	16 34 096 1101 000
backplane version	96	3.7	16 33 096 1201 000

Module version

Backplane version

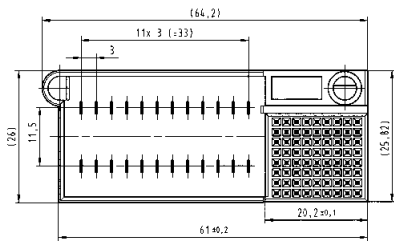

view X

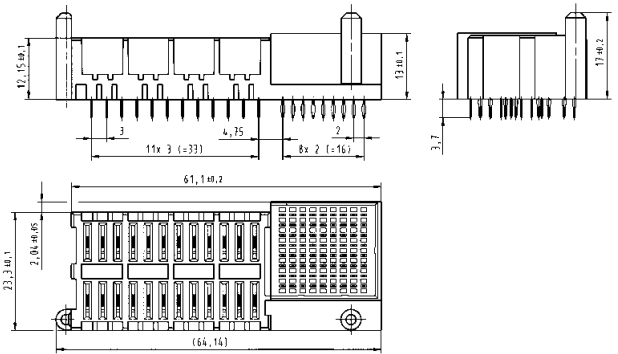
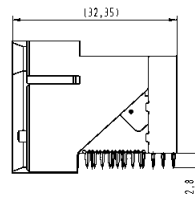

Board drillings

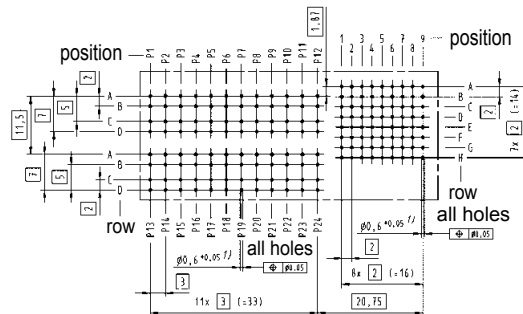
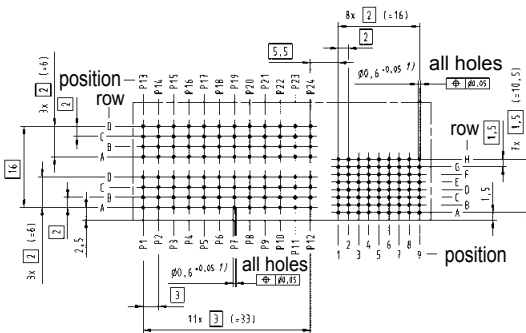

1) recommended plated through hole specification see page 12.14

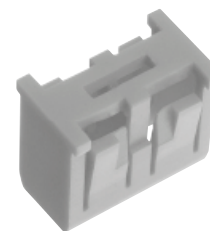

Identification

MicroTCA™ Protection Block

Part number

16 79 000 0010 000

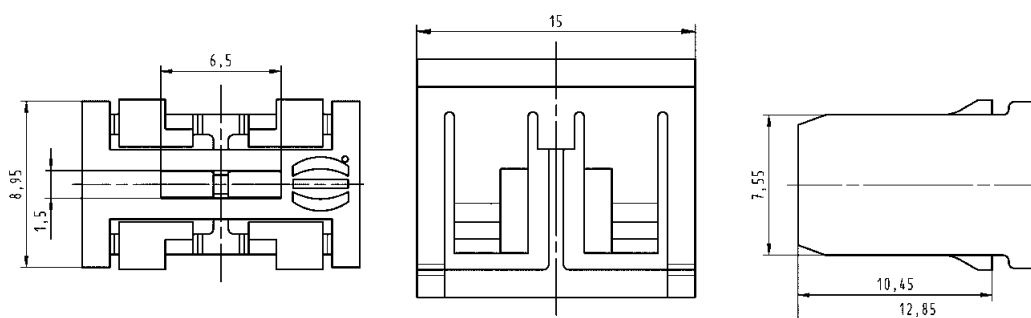

The MicroTCA™ specification defines modules with the option of multiple mating interfaces like the MCH module for system management and switching. There are four different pitches defined for the module interfaces and the backplane connectors respectively, the basic unit is called horizontal pitch (HP) and is 5.08 mm (0.2 inch).

Compact-Size	3 HP	15.24 mm
Mid-Size	4 HP	20.32 mm
Full-Size	6 HP	30.48 mm
MCH	1.5 HP	7.62 mm

Any MCH (or other multiple mating interface modules) with more than two mating interfaces (2x MCH-pitch 1.5 HP = Compact-Size pitch 3 HP) could unintentional mate with connectors of the adjacent slot or could be plugged into the wrong slot. Even though the pin-assignment and e-keying for the MCH is defined, it can cause system failures or even destroy hardware if a MCH is inserted into two adjacent AMC Compact-Size slots. For other multiple mating interface modules, this situation is even worse, because neither e-keying nor pin assignment is specified in MTCA.0.



MicroTCA™ backplane with protection blocks

To prevent errors in case of misinsertion, MTCA.0 R1.0 chapter 2.13 outlines protection blocks that occupy the space between two adjacent connectors in a Compact-Size slot. Furthermore this protection block can be used for keying functions of multiple mating interface modules.

HARTING designed a protection block fully independent of the backplane and sub rack design. The HARTING protection block is clipped between two connectors, hence no fixing features (holes, clips...) need to be designed into the backplane or the sub rack mechanics. The assembly is done quick and easy by hand. It can even be installed easily after the backplane is mounted with a simple flat-head screwdriver, an easy removal is possible in a similar way. The keying block can be placed into four different positions, hence a keying of multitongue modules by using tongues with a cutout is possible.

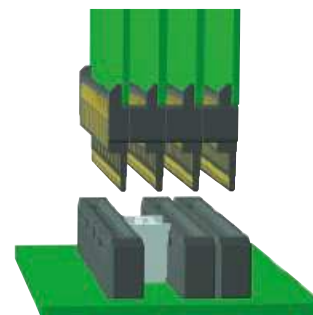

The free space between the backplane connectors is occupied by the protection block

13. Micro Card Edge Connectors

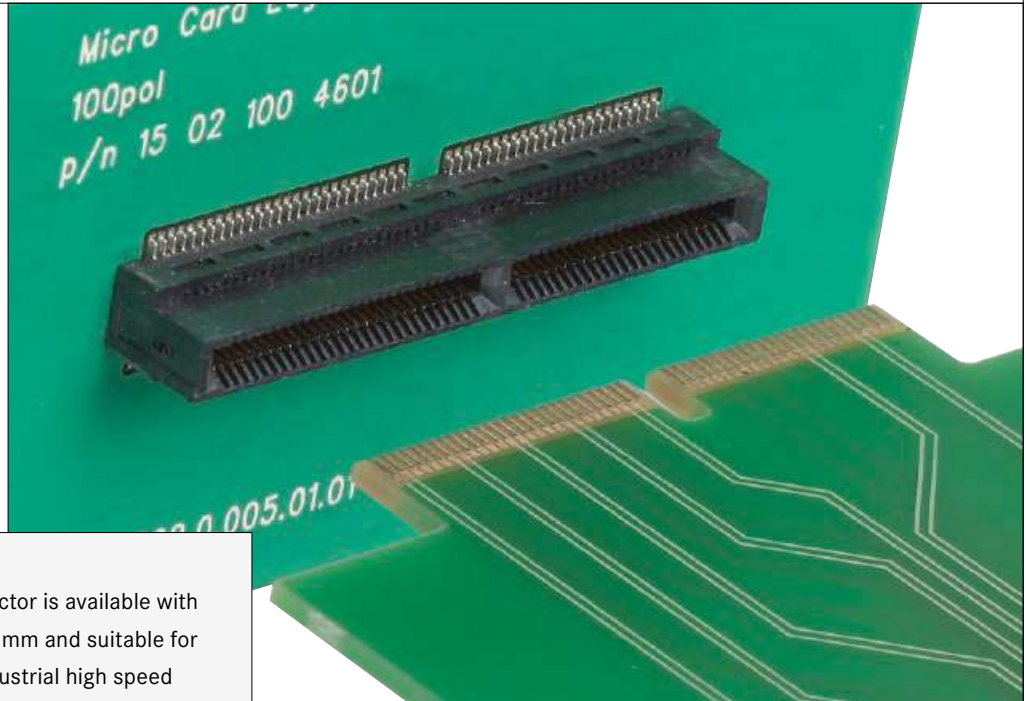

The HARTING Micro Card Edge Connector is available with 40 and 100 contacts at a pitch of 0.8 mm and suitable for telecommunications, medical and industrial high speed applications with data rates up to 14 Gbps.

Application profile:

CONNECTION TYPE		ENVIRONMENT		APPLICATION						
Board to Board	Cable/Wire to Board	IP20	IP65 / IP67	Data	Signal	Power	high performance			
				Data transfer rate	Shielding	Number of contacts, contact density	Voltage, working current			
Cable termination			PCB termination			Application standard				
Han-Quick Lock®	IDC	Crimp	THT	SMC	SMT	SCSI				
Screw	Cage clamp	Axial screw	Press-in	Housing integration		Separate housing		Integrated housing		

Contents

Page

Micro Card Edge connector system – introduction	13.02
Technical characteristics, board dimensions	13.05
40pin connector	13.06
100pin connector	13.07

MICRO CARD EDGE CONNECTORS

HARTING offers the new Micro Card Edge Connector in surface-mounting technology for card gauges of 1.6 mm. It is suitable for board to board mezzanine as well as for small 'pluggable daughter card applications'. The key feature for mezzanine applications is the very flexible stacking height of parallel boards by utilizing a small board between the connectors. This gives flexibility in the mechanical design of the system.

The HARTING Micro Card Edge Connector is able to transfer data rates up to 14 Gbps, suitable for telecommunications, medical

and industrial high speed applications. It is available with 40 and 100 contacts at a pitch of 0.8 mm. An extremely smooth contact surface achieved by high performance stamping tools and a special after - treatment ensures low insertion forces and a high contact reliability.

HARTING's Micro Card Edge Connector offers excellent manufacturing features like a tape & reel packaging with a pick & place pad for nozzle in high volume productions.



High speed data transmission up to 14 Gbps between mezzanine or daughter card boards in telecom, medical, datacom and industrial applications.

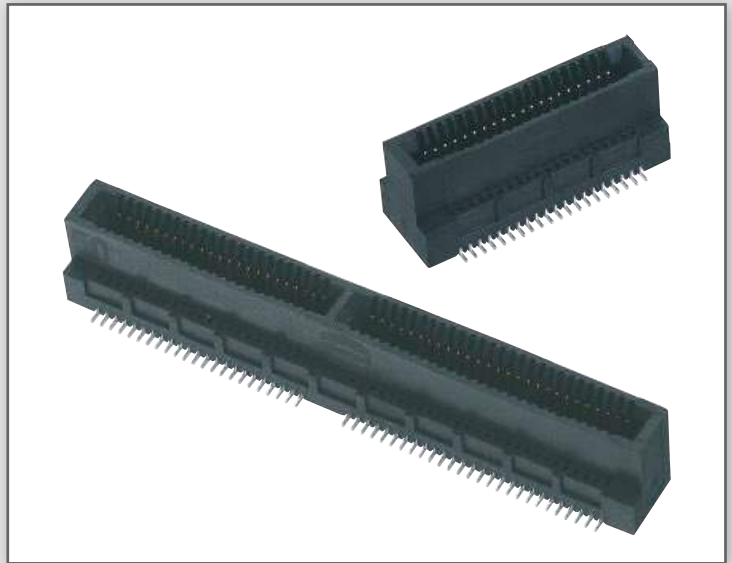

Excellent manufacturing features for high volume production

- SMT termination
- Tape & reel packaging with pick & place pad for nozzle



Flexible stacking height of parallel boards by utilizing a small board between the connectors.

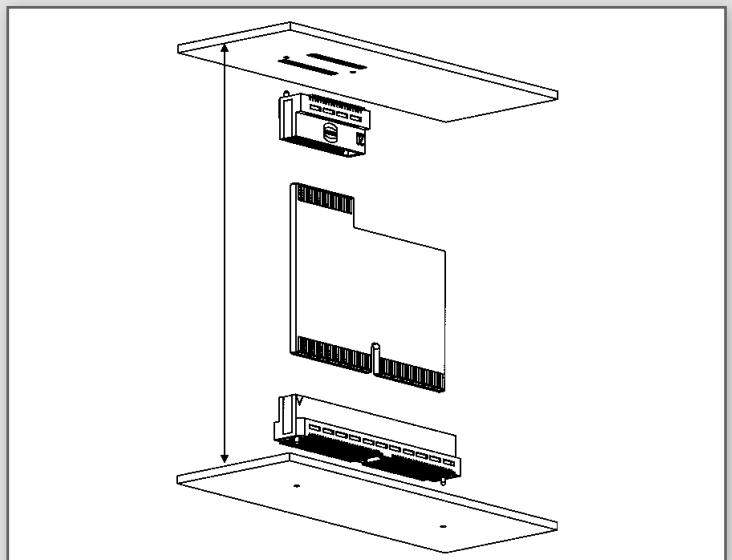

Contact spacing	: 0.8 mm
Working current	: 1.7 A at 80 °C ambient
Test voltage	: 600 V AC
Mating cycles	: 200
Number of contacts	: 40, 100
Mating card thickness	: 1.6 + 0.1 mm
Operating temperature	: -55 °C ... +125 °C
Max processing temperature	: 230 °C for 60 sec. or 260 °C for 20 sec.
ROHS-compliance	: yes
Materials	
Mouldings	: LCP, glass-fibre filled, UL 94-V0
Contacts	: Copper alloy with Ni plating
Contact surface	
Contact zone	: Pd/Ni plating with Au flash
Termination zone	: Sn/Ni plating

Board dimensions

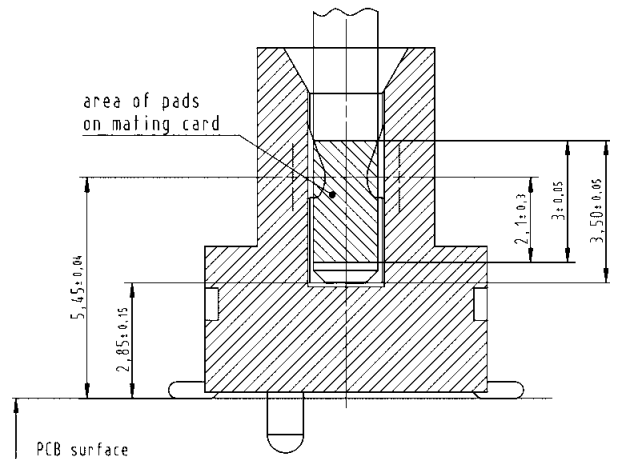
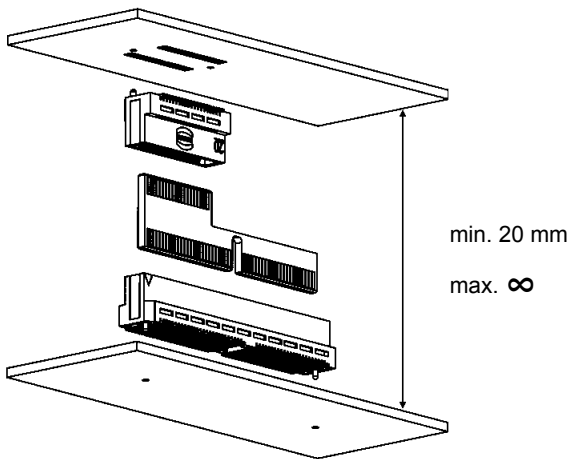

Recommended mating card layout

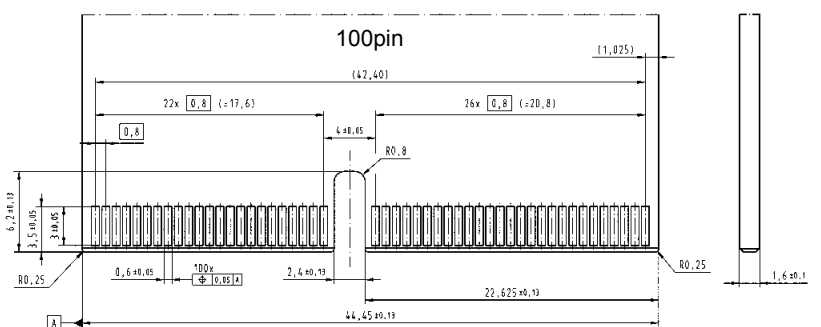
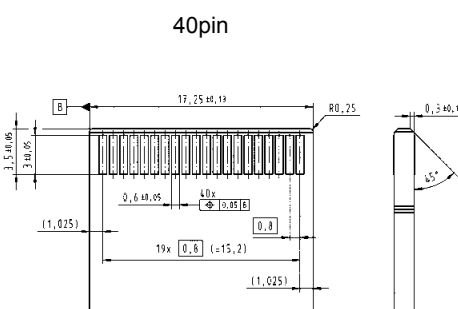



40pin connector

Identification	Number of contacts	Part number	Drawing	Dimensions in mm
Micro Card Edge connector 2800 pieces in a "Tape and Reel" packaging (14 reels with 200 pcs.)	40	15 01 040 4601 040		
200 pieces in a "Tape and Reel" packaging	40	15 01 040 4601 042		
Single connector sample	40	15 01 040 4601 333		
Board layout				
"Tape and Reel" packaging				
Reel dimensions				

MCE

Micro Card Edge connector



100pin connector

Identification	Number of contacts	Part number	Drawing	Dimensions in mm
----------------	--------------------	-------------	---------	------------------

Micro Card Edge connector

1800 pieces in a "Tape and Reel" packaging (9 reels with 200 pcs.)

100

15 02 100 4601 040

200 pieces in a "Tape and Reel" packaging

100

15 02 100 4601 042

Single connector sample

100

15 02 100 4601 333

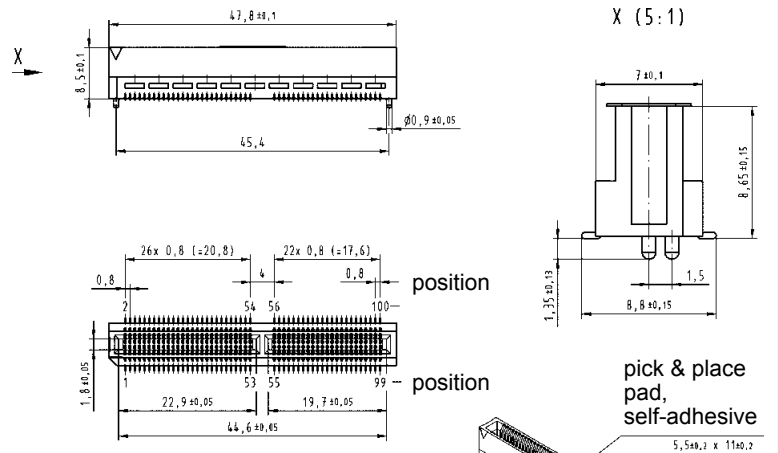

Board layout

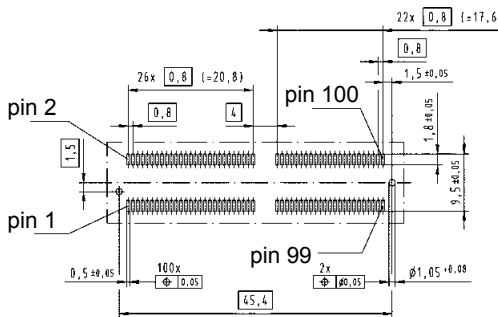

"Tape and Reel" packaging

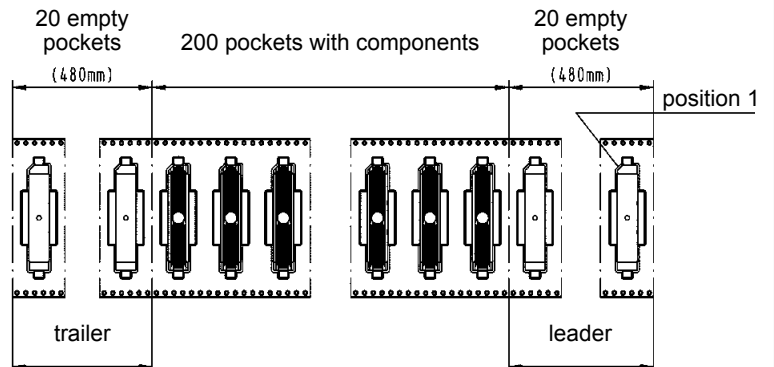

Reel dimensions

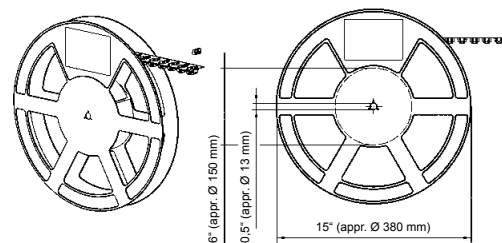

MCE

14. har-flex® Connectors



The continuous scalability by an even number of contacts, i.e. from 6 to 100, of the HARTING's har-flex® mezzanine connector series is a special feature forming an ideal basis for customized applications. The advantage is clearly evident considering that the connector is always optimized to suit specific applications on the device PCB, while also covering the medium- and small-scale volume range that is typical for the production of industrial devices.

Application profile:

CONNECTION TYPE		ENVIRONMENT		APPLICATION						
Board to Board	Cable/Wire to Board	IP20	IP65 / IP67	Data	Signal	Power	high performance			
							Data transfer rate	Shielding	Number of contacts, contact density	Voltage, working current
Cable termination			PCB termination			Application standard				
Han-Quick Lock® 	IDC 	Crimp 	THT 	THR (SMC) 	SMT 	 SCSI				
Screw 	Cage clamp 	Axial screw 	Press-in 	Housing integration						
				Separate housing 	Integrated housing 					

Contents

	Page
<i>har-flex</i> ® connector system – introduction	14.02
Technical characteristics	14.06
Male connectors, straight	14.12
Female connectors, straight	14.16
Male connectors, angled	14.20
Female connectors, angled	14.24
Female connectors with IDC termination	14.26
Cable assemblies	14.30

har-flex® CONNECTORS

With *har-flex*®, HARTING has developed a general-purpose PCB connector series for internal and external Device Connectivity. The continuous scalability by an even number of contacts from 6 to 100 is a special feature forming an ideal basis for customized applications. The advantage is clearly evident considering that the connector is always optimized to suit specific applications on the device PCB, while also covering the medium and small scale volume range that is typical for the production of industrial devices.

This flexibility is new – HARTING turns an individual design into a standard component. No special tooling changes are needed for customer-specific solutions, thus HARTING can realize a short delivery time.

PRODUCT DIVERSITY

The *har-flex*® product range is based on a 1.27 mm grid. With its diverse variants, HARTING provides connectivity solutions for many different board-to-board and cable-to-board applications. For example, two straight connectors are used for mezzanine applications, two angled connectors for extender cards on one level, and a combination of straight and angled connectors allows the well-known pairing of mother and daughtercards. By using individually tailored IDC flat cables, it is possible to bridge long PCB distances.

Smaller, more powerful and more robust at the same time is the credo in all areas on the way to I4.0. Due to the miniaturized design and the high variability of the *har-flex*® connectors, device manufacturers have a freely scalable connection technology that meets the requirements of miniaturization.

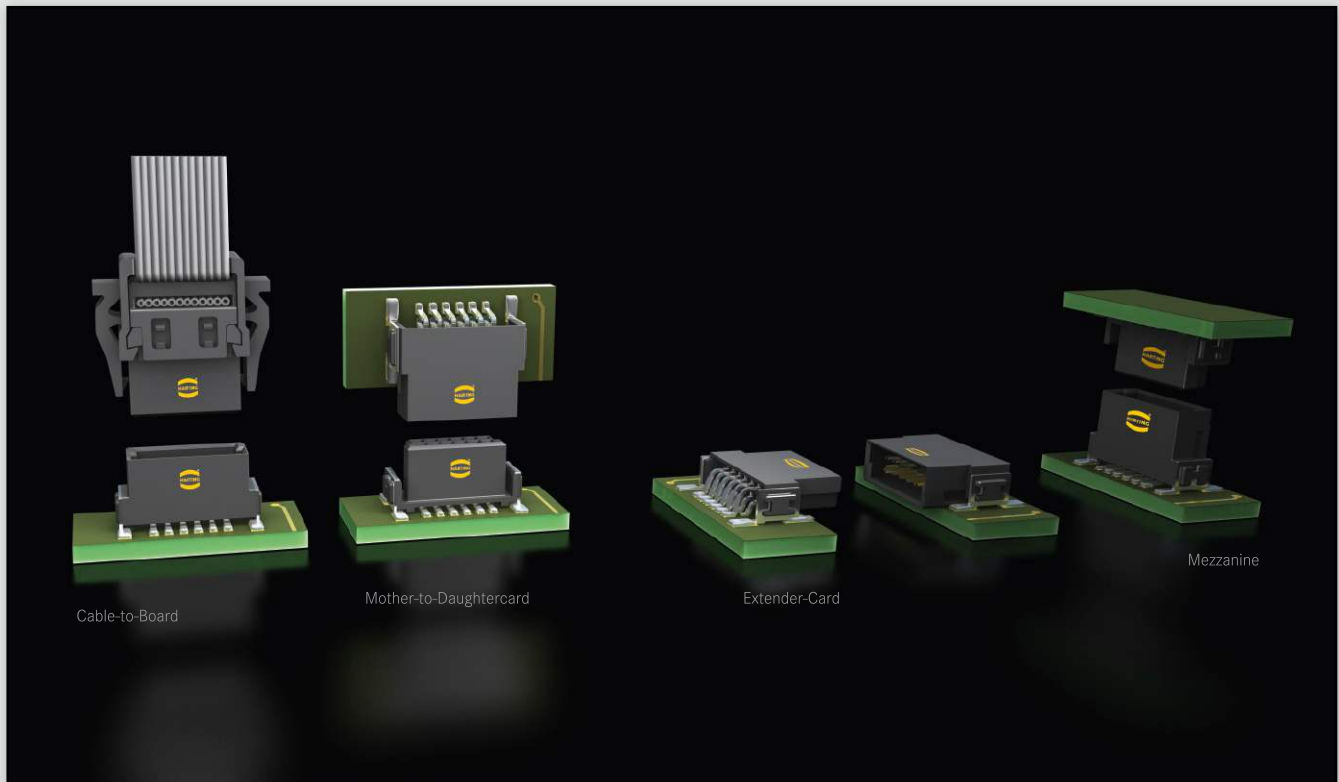

Variable pole counts for highest flexibility

- Male and female connectors with even pole counts from 6 to 100 contacts available
- This flexibility in the choice of number of contacts combined with high density contact spacing allows for an optimal use of PCB space, thereby achieving overall space savings and cost efficiencies

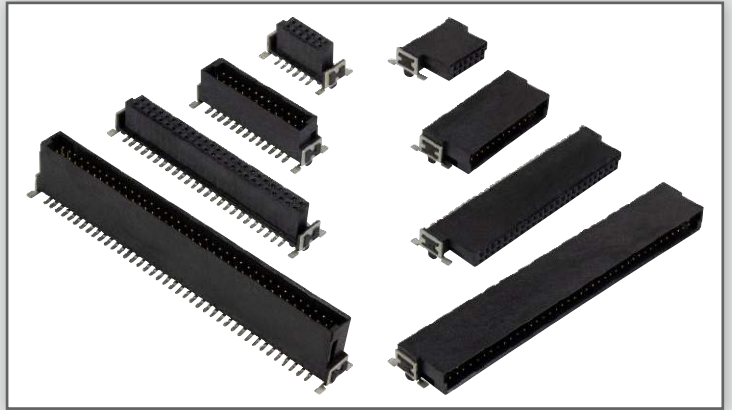

Flexible board-to-board distances

- Different stacking heights and a wiping length of 1.5 mm allow for (mezzanine) board-to-board distances from 8 to 20 mm

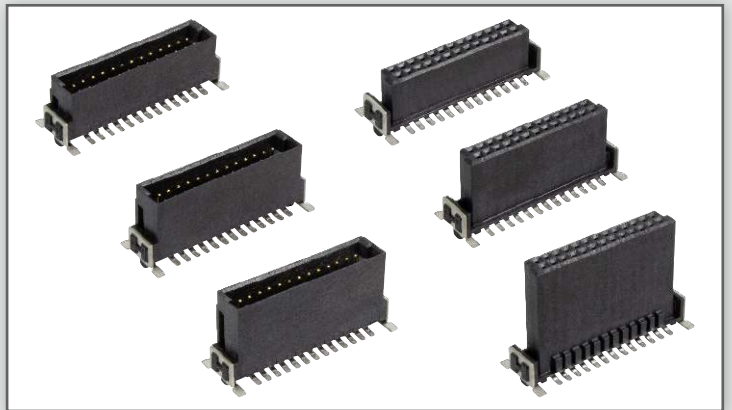

High-quality contacts for a high number of mating cycles

- Polished Performance Level 1 (PL1) contacts ensure reliable connections for up to 500 mating cycles
- A gas test after the initial 250 of 500 mating cycles ensures high quality and long-term reliability

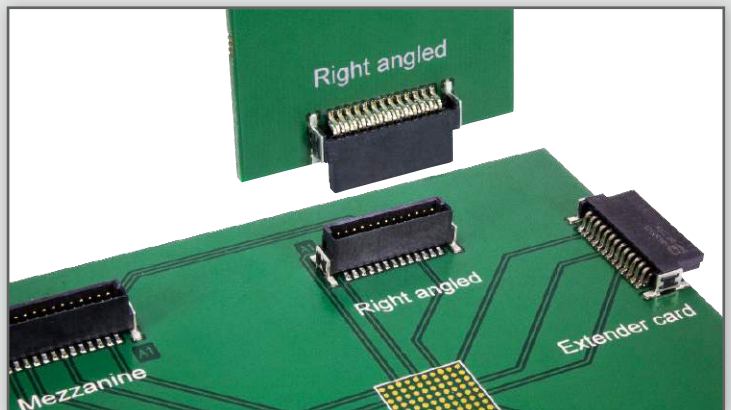

Accurate mating process

- Mating profiles prevent mating in the opposite direction
- Slanted guidances compensate angle and center offsets and ensure a secure mating process

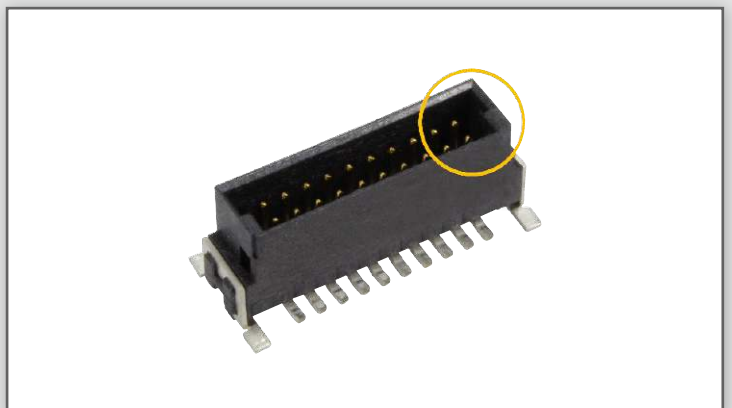

Robust fixation on the PCB

- SMT and THR hold-downs allow for a robust mechanical fixation
- SMT hold-downs reduce the mechanical strain on the signal pins
- THR hold-downs are optionally available for strong protection against particularly high mechanical transverse forces

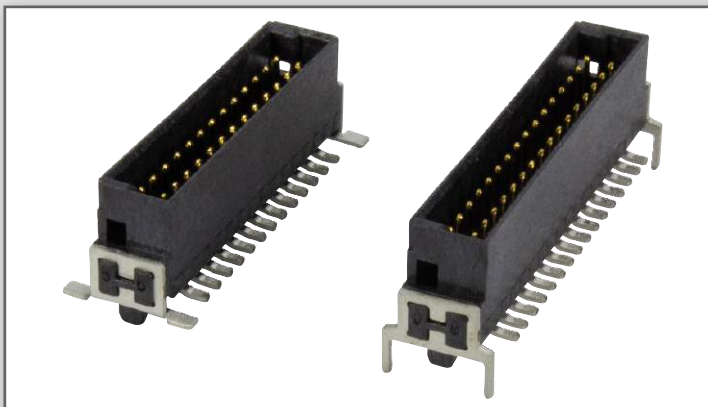

Secure handling of cable connectors

- Vibration-proof catch mechanism on both sides prevents accidental loosening
- Optional strain relief protects the IDC contacts against pulling forces
- Customized cable assemblies provide perfectly fitting solutions



Reliable soldering process

- A reliable soldering process is ensured by a contact coplanarity of ≤ 0.1 mm
- An optimal position on the PCB is achieved by guiding pegs

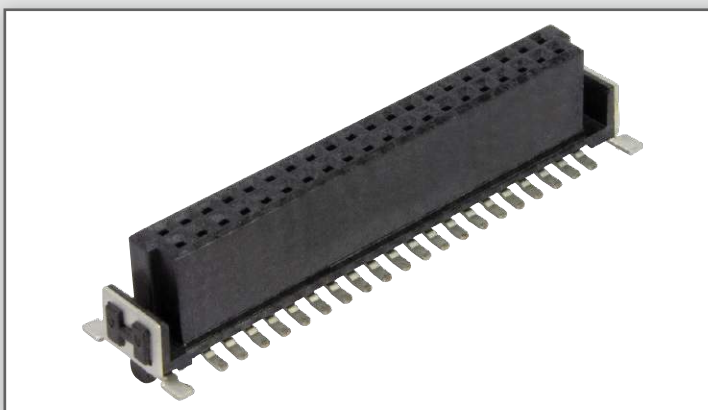

Automated processing features

- Tape & reel packaging provides protection during shipping and handling
- SMT and THR versions are suitable for automatic pick & place assembly and reflow soldering



Different types of cable

- Number of contacts: 6 - 100
- AWG 30/7
- Pitch: 0.635 mm
- Flame retardant acc. UL 758: VW-1
- **Standard (PVC)** Operating temperature: -20 °C ... +105 °C
- **Halogen free (TPE)** Operating temperature: -40 °C ... +125 °C



Customised

We can add value with:

- Ferrit cores
- Shrinking tube
- Customised folding, customised labels

Your cable is not mentioned?

Don't be afraid. We will handle it. Please tell us your requirements.

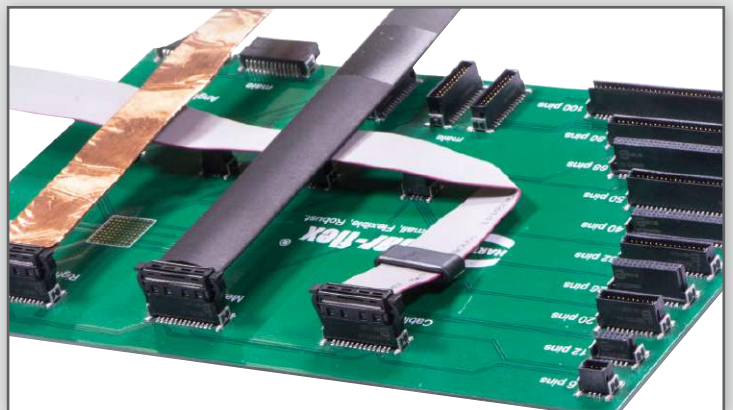

Number of contacts 6, 8, 10 ... 96, 98, 100

Connector pitch 1.27 mm x 1.27 mm [0.050" x 0.050"]

Clearance and creepage distance
 Board connectors (SMT) min. 0.4 mm
 Cable connectors (IDC)
 AWG 30/1 (solid) min. 0.35 mm
 AWG 30/7 (stranded) min. 0.4 mm

Test voltage $U_{r.m.s.}$ 500 V
 Contact resistance < 25 mΩ
 Insulation resistance > 10 GΩ

Insertion and withdrawal force approx. 0.5 N / contact

Working temperature range
 for connectors: - 55 °C ... + 125 °C
 for flat cable assembly: depends on cable type
 The higher temperature limit includes the local ambient and heating effects of the contacts under load
 Temperature during reflow soldering (acc. to ECA/IPC/JEDEC J-STD-075 Level PSL R0) min. 150 s > 217 °C
 min. 30 s > 240 °C

Electrical termination
 Board connectors SMT (Surface Mount Technology) THR
 Cable connectors IDC (Insulation Displacement Connection)

Materials
 Moulding material LCP
 UL approval UL 94-V0
 CTI value (Comparative Tracking Index) 175
 Contacts base material Copper alloy
 Contact surface
 Mating side
 Board connectors Au over PdNi (acc. performance level)
 Cable connectors Au over PdNi (acc. performance level)
 Termination side
 Board connectors (SMT / THR) Sn
 Cable connectors (IDC) Sn

Current carrying capacity acc. to IEC 60512-5-2

The current carrying capacity is limited by maximum temperature of materials for inserts and contacts including terminals. The current capacity-curve is valid for continuous, not interrupted current-loaded contacts of connectors when simultaneous power on all contacts is given, without exceeding the maximum temperature.

Control and test procedures according to DIN IEC 60512-5-2.

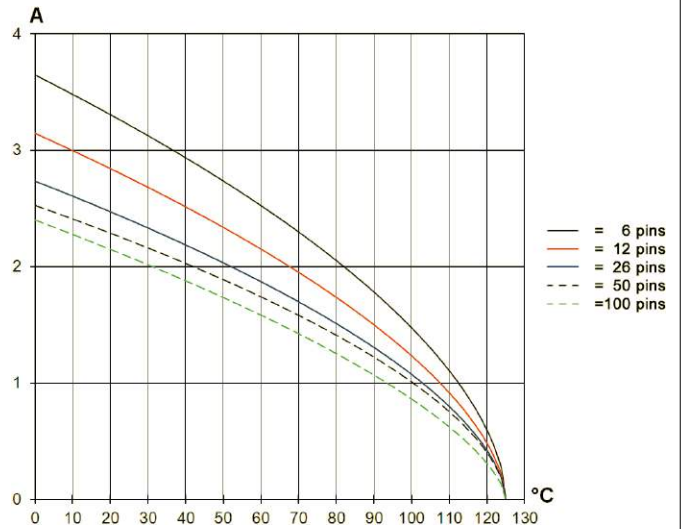

Derating curve @ $I_{max} * 0.8$ (IEC 60512-5-2)

Durability

Performance level 1 (recommended for majority of applications)

Initial 250 mating cycles, 10 days gas test (25 °C/75 % r.h.) using H₂S 10 ppb, NO₂ 200 ppb, CL₂ 10 ppb, SO₂ 200 ppb. Measurement of contact resistance. The remaining 250 mating cycles are subject to measurement of contact resistance and visual inspection. No abrasion of the contact finish through to the base material. No functional impairment.

Part number definition:

Performance level 2 (available on request)

Initial 125 mating cycles, 4 days gas test (25 °C/75% r.h.) using H₂S 10 ppb, NO₂ 200 ppb, CL₂ 10 ppb, SO₂ 200 ppb. Measurement of contact resistance. The remaining 125 mating cycles are subject to measurement of contact resistance and visual inspection. No abrasion of the contact finish through to the base material. No functional impairment.

Part number definition:

Performance level S4 (available on request)

Defined contact surface of min. 0.06 μm Au over 0.7+0.2 μm PdNi.

Part number definition:

harflex

Working voltage acc. to IEC 60664-1

The working voltage depends on user specific operational conditions. Depending on the installation category, the degree of pollution and the entire electrical environment, the working voltage is different. The standard IEC 60664-1 specifies, in general, the minimum insulation distances for equipment. But it can also be used to determine the maximum working voltage with given requirements.

The following table shows the most common conditions applicable for the har-flex® connectors and exemplary calculations for the working voltage. For installation category, degree of pollution and other requirements which are not shown in the table we refer to the IEC 60664-1.

Clearance / Creepage distance	0.4 mm			
CTI-Value	< 400			
Isolation group	III a/b			
Electrical field type	Case A (Inhomogeneous field)		Case B (Homogeneous field)	
Installation category	I	II	I	II
Degree of pollution	1	1	1	1
Working voltage max.	150 V	100 V	150 V	150 V

Explanations:

- CTI value and isolation group are fixed values by the har-flex® connector characteristics.
- Installation category I: Equipment is intended for use only in appliances or installation parts, in which no overvoltages can occur. Equipment in this installation category is normally operated at extra low voltage.
- Installation category II: Equipment is intended for use in installations or parts of installations, in which lightning overvoltages need not be considered. Overvoltages caused by switching must be taken into account.
- Pollution degree 1: No pollution or only dry, non-conductive pollution occurs. The pollution has no influence.
- Pollution degree 2: Only non-conductive pollution occurs. A temporary conductive caused by condensation must be expected occasionally.

har-flex® with THR hold-downs

THR stands for "Through Hole Reflow", which appropriately describes the underlying technology. While SMT (i.e. "Surface Mount Technology") connections are created by soldering the connector on the PCB surface during the reflow soldering process, THR means that the hold-down pins are inserted and soldered into designated holes on the PCB. This combines the fully automatic reflow soldering process with the advantages of traditional wave soldering: the inserted hold-down pins make the har-flex® more stable mechanically and more resilient to shear forces. This is especially relevant for PCB connectors and particularly for applications that require blind mating - meaning that the connectors are hidden from view during the mating process, which increases the chance of high mechanical stresses on the contacts. The resulting risk is mitigated by using hold-downs (additional mechanical fixing features). The optionally available THR hold-downs increase the robustness and reliability and protect the SMT signal contacts, which is particularly useful for angled connectors mounted on daughtercards, for example.

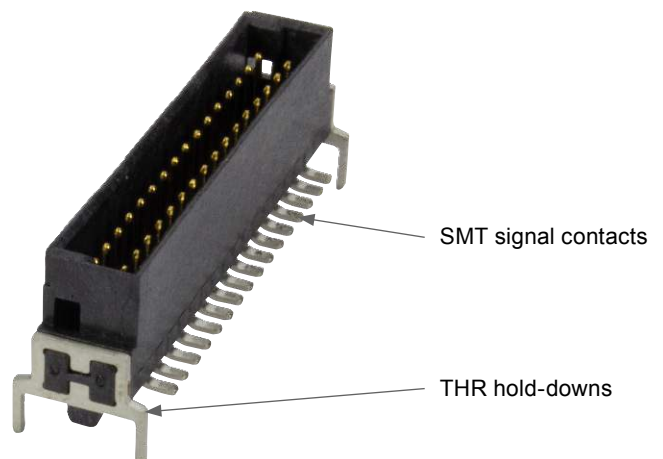
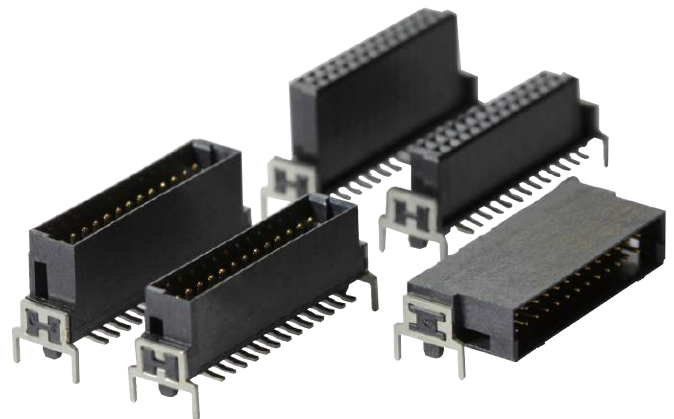

Partial loading

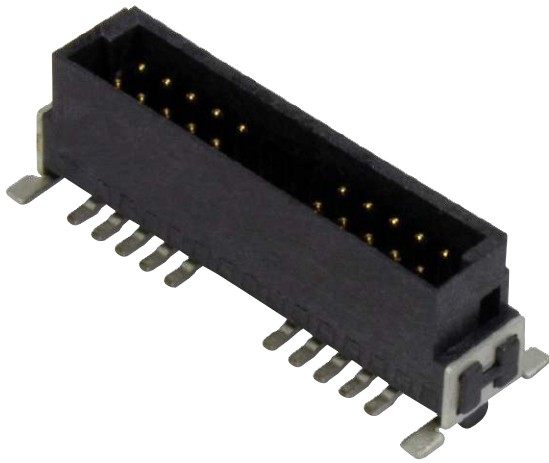

In specific cases it is possible that special requirements are not covered by the available standard variants. For example, it might be necessary to have a higher working voltage or allow for PCB traces under the connector. In such cases, it is possible to load the connector partially, i.e. leave out certain contact pins. By this means it is possible to increase the creepage and clearance distances and create free space for additional PCB tracks under the connector. HARTING offers the possibility to leave out one or several contacts in any position, which ensures a high degree of flexibility.

Reliable contacting

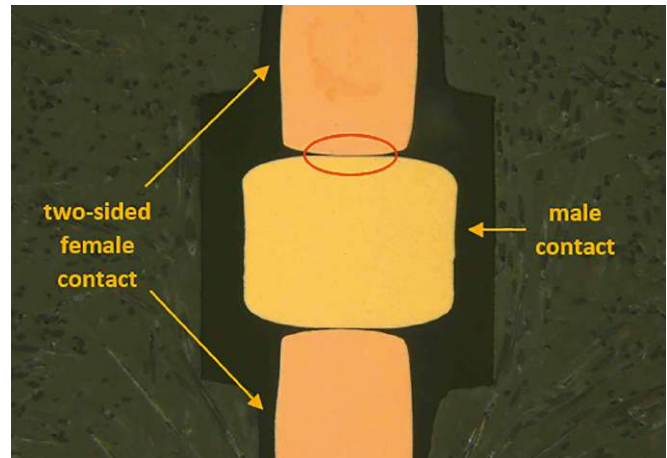

The production of stamped contacts has been one of HARTING's core competencies for a long time. HARTING leveraged this experience to create reliable contacts for *har:flex*®. To achieve this goal, both a high-quality contacting area and a suitable plating are crucial in order to maintain the contacting functionality of the contact over the course of its lifetime. The female contact is made with high precision, and a special polishing process ensures a defined contacting area, so that the contact point features a particularly high quality. In conjunction with the standard plating for performance level 1 this method guarantees a reliable electric connection for at least 500 mating cycles.

Stacking heights for mezzanine applications

Straight male and female har-flex® variants are available in three different stacking heights each. In conjunction with a wiping length of 1.5 mm these har-flex® variants can cover PCB distances from 8 to 20 mm in mezzanine applications.

S	20 mm								
	19 mm								
	18 mm								
	17 mm								
	16 mm								
	15 mm								
	14 mm								
	13 mm								
	12 mm								
	11 mm								
	10 mm								
	9 mm								
8 mm									
X&Y	stacking heights	male 1.75 mm female 6.25 mm	male 3.25 mm female 6.25 mm	male 1.75 mm female 9.05 mm	male 3.25 mm female 9.05 mm	male 4.85 mm female 9.05 mm	male 1.75 mm female 13.65 mm	male 3.25 mm female 13.65 mm	male 4.85 mm female 13.65 mm
S	PCB distance	8 mm - 9.5 mm	9.5 mm - 11 mm	10.8 mm - 12.3 mm	12.3 mm - 13.8 mm	13.9 mm - 15.4 mm	15.4 mm - 16.9 mm	16.9 mm - 18.4 mm	18.5 mm - 20 mm
	part numbers	1511... 1521...	1512... 1521...	1511... 1522...	1512... 1522...	1513... 1522...	1511... 1523...	1512... 1523...	1513... 1523...

Mating options

Mezzanine connection

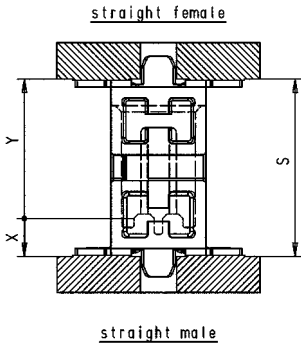

4.85	13.65	18.50	20.00
3.25	13.65	16.90	18.40
1.75	13.65	15.40	16.90
4.85	9.05	13.90	15.40
3.25	9.05	12.30	13.80
1.75	9.05	10.80	12.30
4.85	6.25	11.10	12.60
3.25	6.25	9.50	11.00
1.75	6.25	8.00	9.50
X	Y	S _{min}	*S _{max}

*S_{max} = S_{min} + 1.5 mm wiping length with additional contact overlap security

Extender Card connection

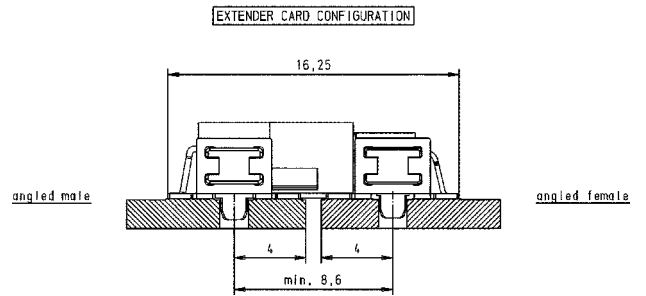

Mother-to-Daughtercard connection

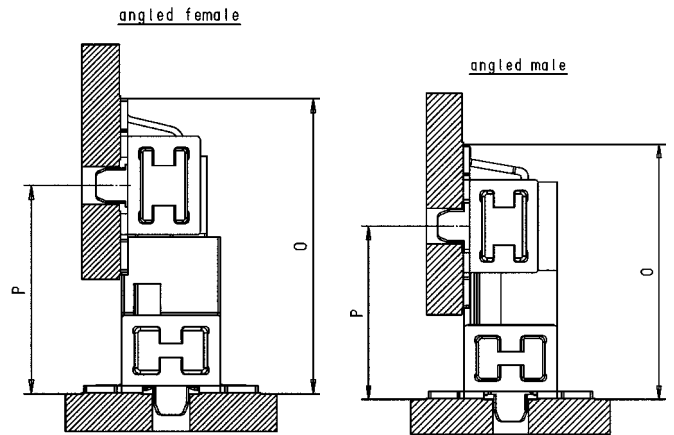

4.85	11.85	15.68
3.25	10.25	14.08
1.75	8.75	12.58
X	P _{min}	O

13.65	15.10	18.93
9.05	10.50	14.33
6.25	7.70	11.53
Y	P _{min}	O

Mating conditions

Inclination

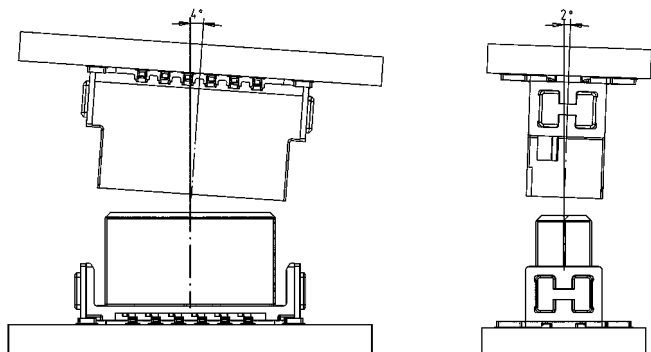

Mismatching

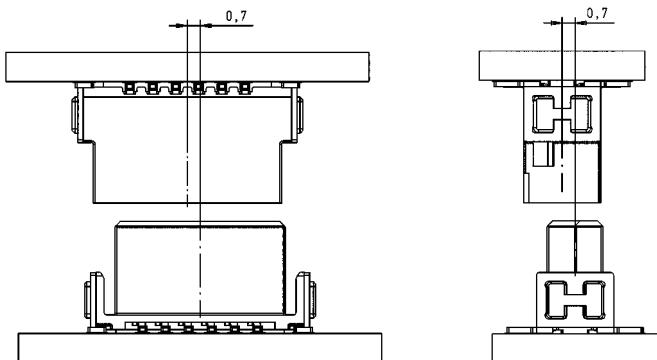

Tape acc. to IEC 60286-3

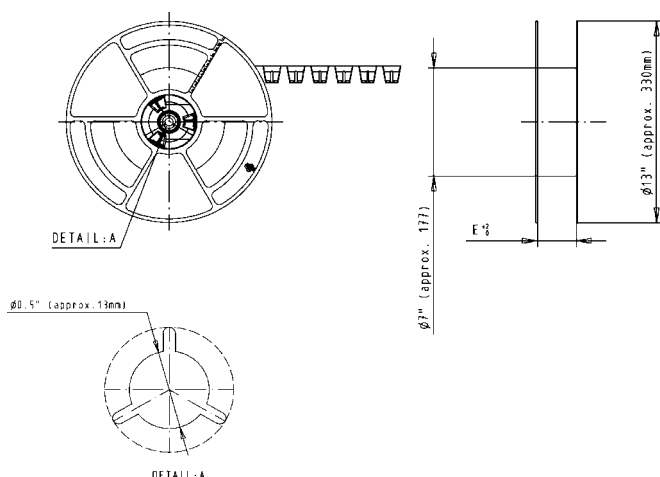

Tape dimensions:	E
poles 6 to 12	24.4
poles 14 to 20	32.4
poles 22 to 40	44.4
poles 42 to 56	56.4
poles 58 to 80	72.4
poles 82 to 100	88.4

Processing notes

The har:flex® SMT/THR connectors meet the highest demands in terms of their processing capabilities.

The connectors are delivered in a tape and reel packaging optimized for automatic assembly machines. A vacuum cover enables the automatic assembly with a vacuum nozzle.

The insulation body material is high temperature resistant, and due to the black colour a secure camera recognition is ensured.

To ensure a reliable reflow soldering process, the signal pins are 100 % checked for coplanarity.

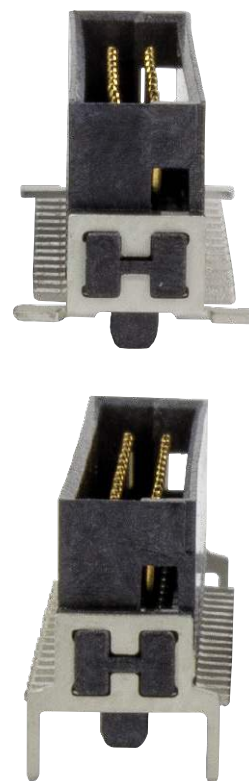

Process / Moisture Sensitivity

During the reflow solder process, the connector has to resist extreme variations in temperature. Connectors consist in general of both plastic and metal parts, which have a different behaviour during the solder process. The Process Sensivity and also the Moisture Sensivity are tested according the ECA/IPC/JEDEC J-STD-075 specification.

Process Sensivity:

PSL means Process Sensivity Level. PSL is a rating used to identify a component that is solder process sensitive. Damages of the connector after three times soldering are not permitted (e.g. melted edges).

Moisture Sensivity:

MSL means Moisture Sensivity Level. MSL is a rating indicating a component's susceptibility to damage due to absorbed moisture during storage. Damages of the connector after storage in damp heat and three times soldering are not permitted (e.g. blisters).

The har:flex® connectors are rated with **PSL R0** and **MSL 1**. This is the maximum possible rating in both categories. The har:flex® connector resists three times soldering at the following conditions without damages:

- min. 150 s beyond 217 °C (liquidus temperature, the melting point of the solder paste)
- min. 30 s beyond classification temperature (240 °C / 245 °C for har:flex®)
- Temperature solder profile according to ECA/IPC/JEDEC J-STD-075
- For MSL test, a storage of 168 hours at 85 °C and 85 % rel. humidity was carried out

As the result, the har:flex® connectors are not process sensitive and not moisture sensitive according to ECA/IPC/JEDEC J-STD-075.

Part number definition

The har-flex® part numbers have 14 digits and are based on the following scheme:

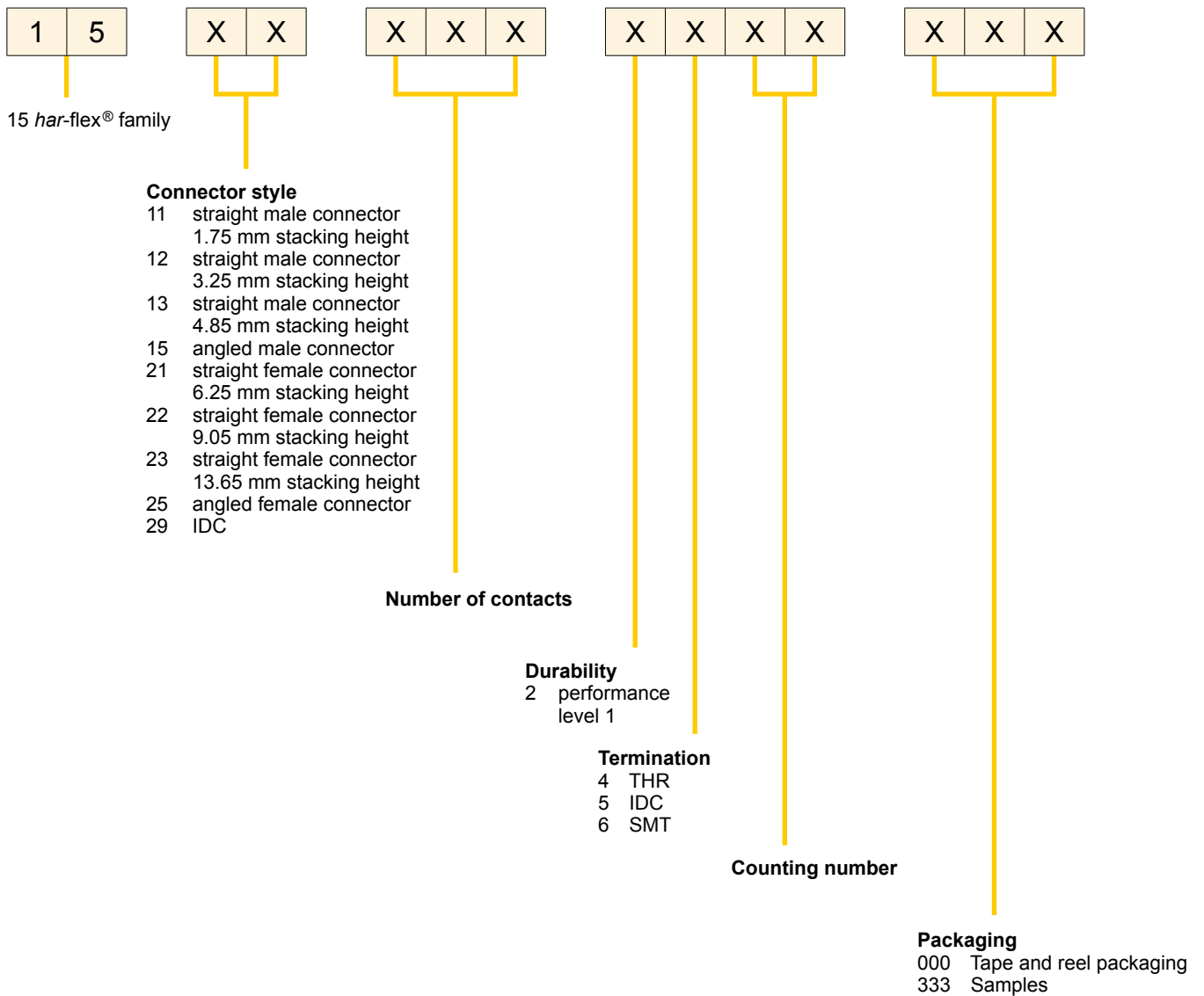

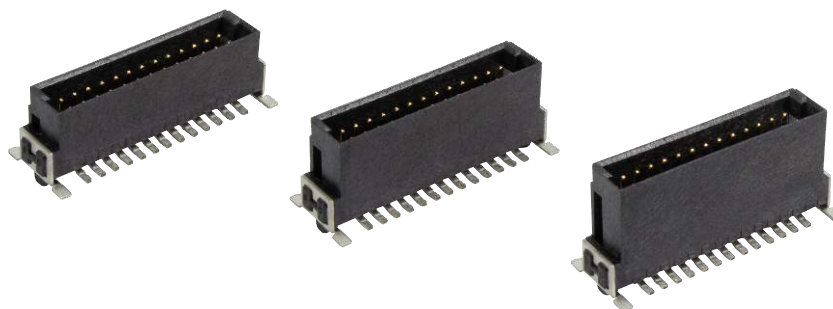

Male connectors, straight, SMT

Identification	No. of contacts	Part number	Dimensions in mm						
			A	B	C	D	E	F	G
Male connector, straight, SMT stacking heights 1.75 mm / 3.25 mm / 4.85 mm	6	15 1 . 006 2601 ...	2.54	6.96	8.89	5.76	4.76	6.56	1.05
	8	15 1 . 008 2601 ...	3.81	8.23	10.16	7.03	6.03	7.83	1.69
	10	15 1 . 010 2601 ...	5.08	9.50	11.43	8.30	7.30	9.10	2.32
	12	15 1 . 012 2601 ...	6.35	10.77	12.70	9.57	8.57	10.37	2.96
	14	15 1 . 014 2601 ...	7.62	12.04	13.97	10.84	9.84	11.64	3.59
	16	15 1 . 016 2601 ...	8.89	13.31	15.24	12.11	11.11	12.91	4.23
	18	15 1 . 018 2601 ...	10.16	14.58	16.51	13.38	12.38	14.18	4.88
	20	15 1 . 020 2601 ...	11.43	15.85	17.78	14.65	13.65	15.45	5.50
	22	15 1 . 022 2601 ...	12.70	17.12	19.05	15.92	14.92	16.72	6.13
	24	15 1 . 024 2601 ...	13.97	18.39	20.32	17.19	16.19	17.99	6.77
	26	15 1 . 026 2601 ...	15.24	19.66	21.59	18.46	17.46	19.26	7.40
	28	15 1 . 028 2601 ...	16.51	20.93	22.86	19.73	18.73	20.53	8.04
	30	15 1 . 030 2601 ...	17.78	22.20	24.13	21.00	20.00	21.80	8.67
	32	15 1 . 032 2601 ...	19.05	23.47	25.40	22.27	21.27	23.07	9.31
	34	15 1 . 034 2601 ...	20.32	24.74	26.67	23.54	22.54	24.34	9.94
	36	15 1 . 036 2601 ...	21.59	26.01	27.94	24.81	23.81	25.61	10.58
	38	15 1 . 038 2601 ...	22.86	27.28	29.21	26.08	25.08	26.88	11.21
	40	15 1 . 040 2601 ...	24.13	28.55	30.48	27.35	26.35	28.15	11.85
	42	15 1 . 042 2601 ...	25.40	29.82	31.75	28.62	27.62	29.42	12.48
	44	15 1 . 044 2601 ...	26.67	31.09	33.02	29.89	28.89	30.69	13.12
	46	15 1 . 046 2601 ...	27.94	32.36	34.29	31.16	30.16	31.96	13.75
	48	15 1 . 048 2601 ...	29.21	33.63	35.56	32.43	31.43	33.23	14.39
	50	15 1 . 050 2601 ...	30.48	34.90	36.83	33.70	32.70	34.50	15.02
	52	15 1 . 052 2601 ...	31.75	36.17	38.10	34.97	33.97	35.77	15.66
	54	15 1 . 054 2601 ...	33.02	37.44	39.37	36.24	35.24	37.04	16.29
	56	15 1 . 056 2601 ...	34.29	38.71	40.64	37.51	36.51	38.31	16.93
	58	15 1 . 058 2601 ...	35.56	39.98	41.91	38.78	37.78	39.58	17.56
	60	15 1 . 060 2601 ...	36.83	41.25	43.18	40.05	39.05	40.85	18.20
	62	15 1 . 062 2601 ...	38.10	42.52	44.45	41.32	40.32	42.12	18.83
	64	15 1 . 064 2601 ...	39.37	43.79	45.72	42.59	41.59	43.39	19.47
	66	15 1 . 066 2601 ...	40.64	45.06	46.99	43.86	42.86	44.66	20.10
	68	15 1 . 068 2601 ...	41.91	46.33	48.26	45.13	44.13	45.93	20.74
	70	15 1 . 070 2601 ...	43.18	47.60	49.53	46.40	45.40	47.20	21.37
	72	15 1 . 072 2601 ...	44.45	48.87	50.80	47.67	46.67	48.47	22.01
	74	15 1 . 074 2601 ...	45.72	50.14	52.07	48.94	47.94	49.74	22.64
	76	15 1 . 076 2601 ...	46.99	51.41	53.34	50.21	49.21	51.01	23.28
	78	15 1 . 078 2601 ...	48.26	52.68	54.61	51.48	50.48	52.28	23.91
	80	15 1 . 080 2601 ...	49.53	53.95	55.88	52.75	51.75	53.55	24.55
	82	15 1 . 082 2601 ...	50.80	55.22	57.15	54.02	53.02	54.82	25.18
	84	15 1 . 084 2601 ...	52.07	56.49	58.42	55.29	54.29	56.09	25.82
	86	15 1 . 086 2601 ...	53.34	57.76	59.69	56.56	55.56	57.36	26.45
	88	15 1 . 088 2601 ...	54.61	59.03	60.96	57.83	56.83	58.63	27.09
	90	15 1 . 090 2601 ...	55.88	60.30	62.23	59.10	58.10	59.90	27.72
	92	15 1 . 092 2601 ...	57.15	61.57	63.50	60.37	59.37	61.17	28.36
	94	15 1 . 094 2601 ...	58.42	62.84	64.77	61.64	60.64	62.44	28.99
	96	15 1 . 096 2601 ...	59.69	64.11	66.04	62.91	61.91	63.71	29.63
	98	15 1 . 098 2601 ...	60.96	65.38	67.31	64.18	63.18	64.98	30.26
	100	15 1 . 100 2601 ...	62.23	66.65	68.58	65.45	64.45	66.25	30.90

Please insert digit for stacking height

- 1.75 mm ► 1
- 3.25 mm ► 2
- 4.85 mm ► 3

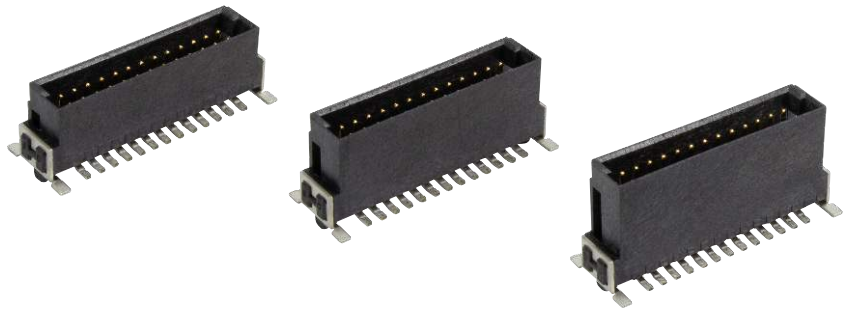

Male connectors, straight, SMT

Identification

Drawing

Dimensions in mm

Dimensions

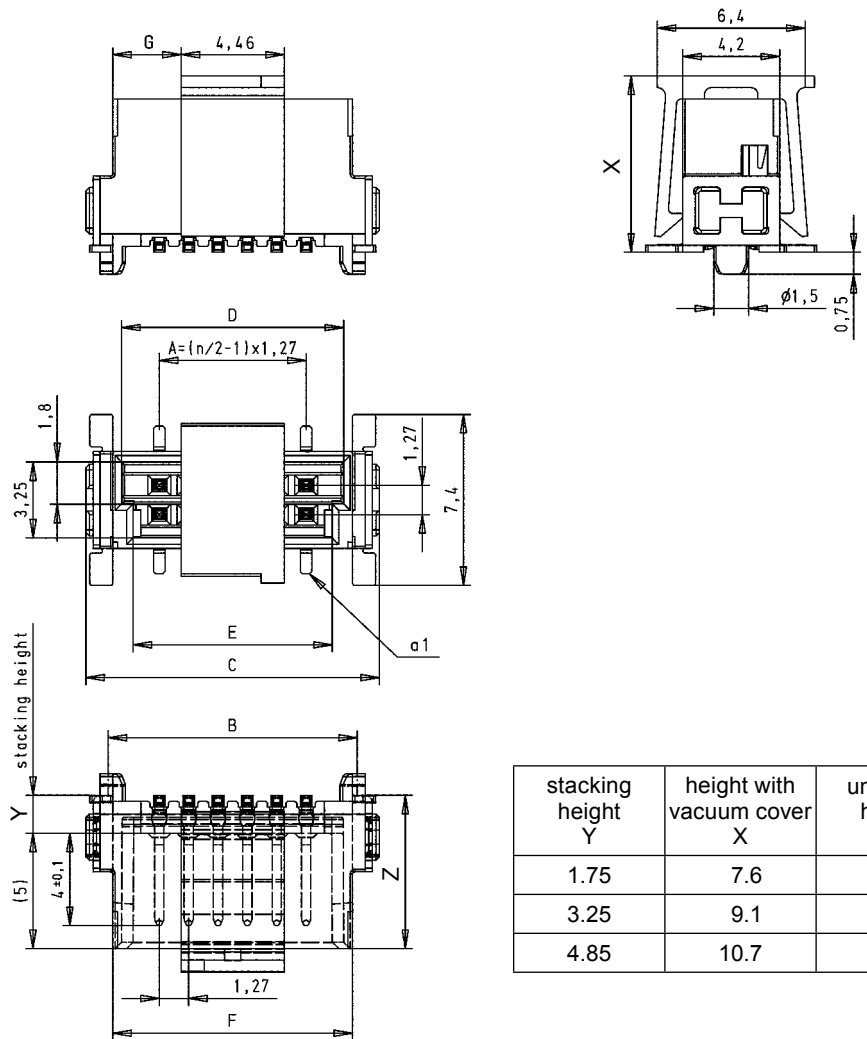

PCB layout

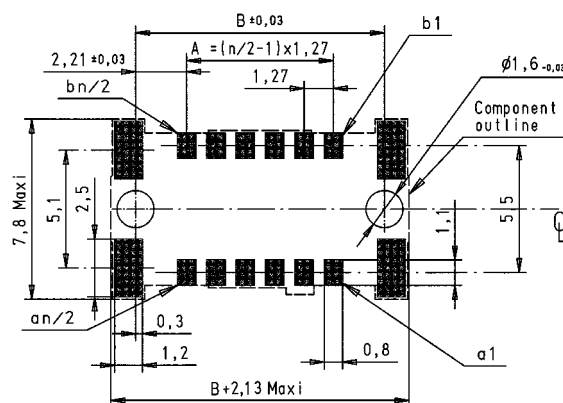

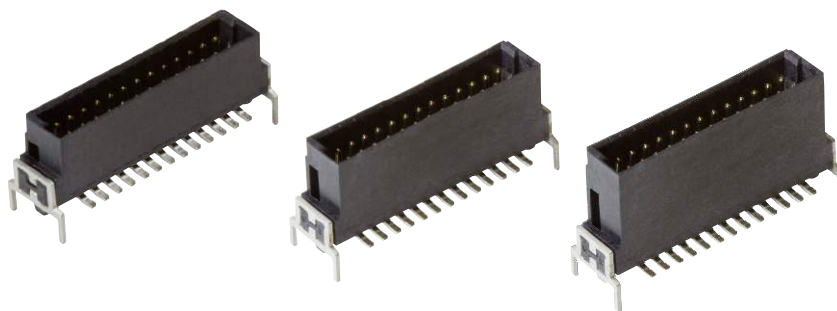

Male connectors, straight, THR

Identification	No. of contacts	Part number	Dimensions in mm						
			A	B	C	D	E	F	G
Male connector, straight, THR stacking heights 1.75 mm / 3.25 mm / 4.85 mm	6	15 1 . 006 2401 ...	2.54	6.96	8.89	5.76	4.76	6.56	1.05
	8	15 1 . 008 2401 ...	3.81	8.23	10.16	7.03	6.03	7.83	1.69
	10	15 1 . 010 2401 ...	5.08	9.50	11.43	8.30	7.30	9.10	2.32
	12	15 1 . 012 2401 ...	6.35	10.77	12.70	9.57	8.57	10.37	2.96
	14	15 1 . 014 2401 ...	7.62	12.04	13.97	10.84	9.84	11.64	3.59
	16	15 1 . 016 2401 ...	8.89	13.31	15.24	12.11	11.11	12.91	4.23
	18	15 1 . 018 2401 ...	10.16	14.58	16.51	13.38	12.38	14.18	4.88
	20	15 1 . 020 2401 ...	11.43	15.85	17.78	14.65	13.65	15.45	5.50
	22	15 1 . 022 2401 ...	12.70	17.12	19.05	15.92	14.92	16.72	6.13
	24	15 1 . 024 2401 ...	13.97	18.39	20.32	17.19	16.19	17.99	6.77
	26	15 1 . 026 2401 ...	15.24	19.66	21.59	18.46	17.46	19.26	7.40
	28	15 1 . 028 2401 ...	16.51	20.93	22.86	19.73	18.73	20.53	8.04
	30	15 1 . 030 2401 ...	17.78	22.20	24.13	21.00	20.00	21.80	8.67
	32	15 1 . 032 2401 ...	19.05	23.47	25.40	22.27	21.27	23.07	9.31
	34	15 1 . 034 2401 ...	20.32	24.74	26.67	23.54	22.54	24.34	9.94
	36	15 1 . 036 2401 ...	21.59	26.01	27.94	24.81	23.81	25.61	10.58
	38	15 1 . 038 2401 ...	22.86	27.28	29.21	26.08	25.08	26.88	11.21
	40	15 1 . 040 2401 ...	24.13	28.55	30.48	27.35	26.35	28.15	11.85
	42	15 1 . 042 2401 ...	25.40	29.82	31.75	28.62	27.62	29.42	12.48
	44	15 1 . 044 2401 ...	26.67	31.09	33.02	29.89	28.89	30.69	13.12
	46	15 1 . 046 2401 ...	27.94	32.36	34.29	31.16	30.16	31.96	13.75
	48	15 1 . 048 2401 ...	29.21	33.63	35.56	32.43	31.43	33.23	14.39
	50	15 1 . 050 2401 ...	30.48	34.90	36.83	33.70	32.70	34.50	15.02
	52	15 1 . 052 2401 ...	31.75	36.17	38.10	34.97	33.97	35.77	15.66
	54	15 1 . 054 2401 ...	33.02	37.44	39.37	36.24	35.24	37.04	16.29
	56	15 1 . 056 2401 ...	34.29	38.71	40.64	37.51	36.51	38.31	16.93
	58	15 1 . 058 2401 ...	35.56	39.98	41.91	38.78	37.78	39.58	17.56
	60	15 1 . 060 2401 ...	36.83	41.25	43.18	40.05	39.05	40.85	18.20
	62	15 1 . 062 2401 ...	38.10	42.52	44.45	41.32	40.32	42.12	18.83
	64	15 1 . 064 2401 ...	39.37	43.79	45.72	42.59	41.59	43.39	19.47
	66	15 1 . 066 2401 ...	40.64	45.06	46.99	43.86	42.86	44.66	20.10
	68	15 1 . 068 2401 ...	41.91	46.33	48.26	45.13	44.13	45.93	20.74
	70	15 1 . 070 2401 ...	43.18	47.60	49.53	46.40	45.40	47.20	21.37
	72	15 1 . 072 2401 ...	44.45	48.87	50.80	47.67	46.67	48.47	22.01
	74	15 1 . 074 2401 ...	45.72	50.14	52.07	48.94	47.94	49.74	22.64
	76	15 1 . 076 2401 ...	46.99	51.41	53.34	50.21	49.21	51.01	23.28
	78	15 1 . 078 2401 ...	48.26	52.68	54.61	51.48	50.48	52.28	23.91
	80	15 1 . 080 2401 ...	49.53	53.95	55.88	52.75	51.75	53.55	24.55
	82	15 1 . 082 2401 ...	50.80	55.22	57.15	54.02	53.02	54.82	25.18
	84	15 1 . 084 2401 ...	52.07	56.49	58.42	55.29	54.29	56.09	25.82
	86	15 1 . 086 2401 ...	53.34	57.76	59.69	56.56	55.56	57.36	26.45
	88	15 1 . 088 2401 ...	54.61	59.03	60.96	57.83	56.83	58.63	27.09
	90	15 1 . 090 2401 ...	55.88	60.30	62.23	59.10	58.10	59.90	27.72
	92	15 1 . 092 2401 ...	57.15	61.57	63.50	60.37	59.37	61.17	28.36
	94	15 1 . 094 2401 ...	58.42	62.84	64.77	61.64	60.64	62.44	28.99
	96	15 1 . 096 2401 ...	59.69	64.11	66.04	62.91	61.91	63.71	29.63
	98	15 1 . 098 2401 ...	60.96	65.38	67.31	64.18	63.18	64.98	30.26
	100	15 1 . 100 2401 ...	62.23	66.65	68.58	65.45	64.45	66.25	30.90

Please insert digit for stacking height

- 1.75 mm ► 1
- 3.25 mm ► 2
- 4.85 mm ► 3

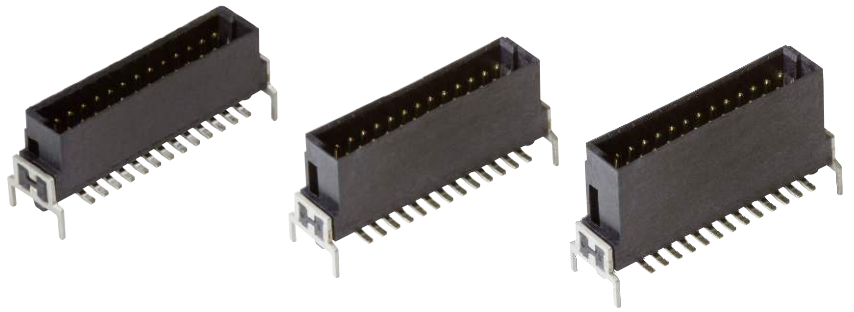

Male connectors, straight, THR

Identification

Drawing

Dimensions in mm

Dimensions

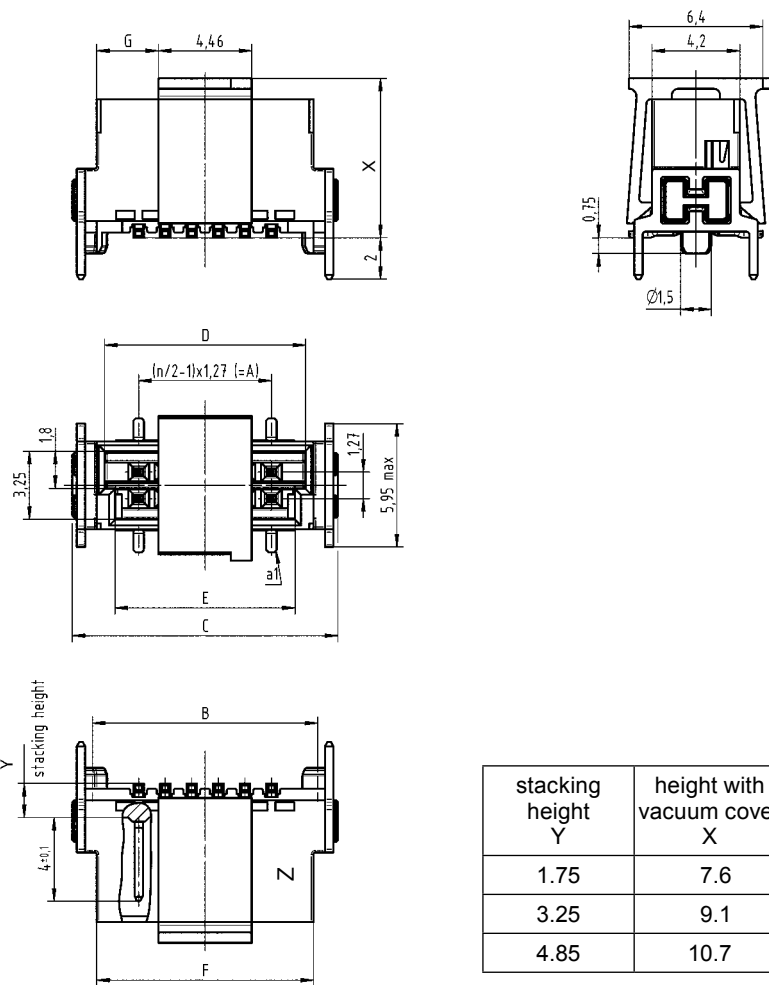

PCB layout

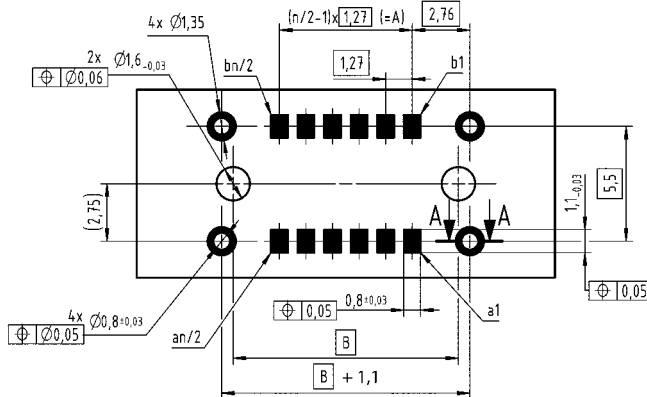

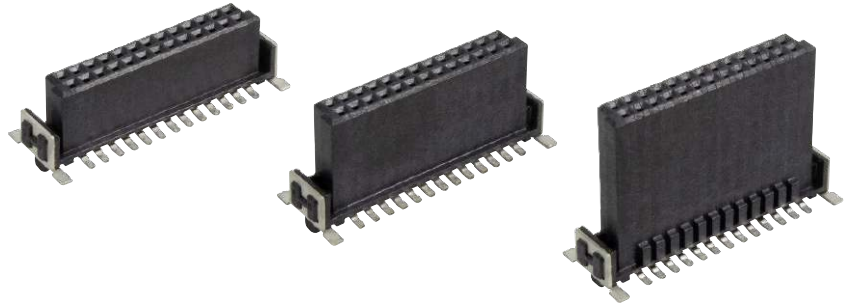

Female connectors, straight, SMT

Identification	No. of contacts	Part number	Dimensions in mm					
			A	B	C	D	E	G
Female connector, straight, SMT stacking heights 6.25 / 9.05 / 13.65 mm	6	15 2 . 006 2601 ...	2.54	6.96	8.89	5.56	4.56	1.19
	8	15 2 . 008 2601 ...	3.81	8.23	10.16	6.83	5.83	1.19
	10	15 2 . 010 2601 ...	5.08	9.50	11.43	8.10	7.10	2.46
	12	15 2 . 012 2601 ...	6.35	10.77	12.70	9.37	8.37	2.46
	14	15 2 . 014 2601 ...	7.62	12.04	13.97	10.64	9.64	3.73
	16	15 2 . 016 2601 ...	8.89	13.31	15.24	11.91	10.91	3.73
	18	15 2 . 018 2601 ...	10.16	14.58	16.51	13.18	12.18	5.00
	20	15 2 . 020 2601 ...	11.43	15.85	17.78	14.45	13.45	5.00
	22	15 2 . 022 2601 ...	12.70	17.12	19.05	15.72	14.72	6.27
	24	15 2 . 024 2601 ...	13.97	18.39	20.32	16.99	15.99	6.27
	26	15 2 . 026 2601 ...	15.24	19.66	21.59	18.26	17.26	7.54
	28	15 2 . 028 2601 ...	16.51	20.93	22.86	19.53	18.53	7.54
	30	15 2 . 030 2601 ...	17.78	22.20	24.13	20.80	19.80	8.81
	32	15 2 . 032 2601 ...	19.05	23.47	25.40	22.07	21.07	8.81
	34	15 2 . 034 2601 ...	20.32	24.74	26.67	23.34	22.34	10.08
	36	15 2 . 036 2601 ...	21.59	26.01	27.94	24.61	23.61	10.08
	38	15 2 . 038 2601 ...	22.86	27.28	29.21	25.88	24.88	11.35
	40	15 2 . 040 2601 ...	24.13	28.55	30.48	27.15	26.15	11.35
	42	15 2 . 042 2601 ...	25.40	29.82	31.75	28.42	27.42	12.62
	44	15 2 . 044 2601 ...	26.67	31.09	33.02	29.69	28.69	12.62
	46	15 2 . 046 2601 ...	27.94	32.36	34.29	30.96	29.96	13.89
	48	15 2 . 048 2601 ...	29.21	33.63	35.56	32.23	31.23	13.89
	50	15 2 . 050 2601 ...	30.48	34.90	36.83	33.50	32.50	15.16
	52	15 2 . 052 2601 ...	31.75	36.17	38.10	34.77	33.77	15.16
	54	15 2 . 054 2601 ...	33.02	37.44	39.37	36.04	35.04	16.43
	56	15 2 . 056 2601 ...	34.29	38.71	40.64	37.31	36.31	16.43
	58	15 2 . 058 2601 ...	35.56	39.98	41.91	38.58	37.58	17.70
	60	15 2 . 060 2601 ...	36.83	41.25	43.18	39.85	38.85	17.70
	62	15 2 . 062 2601 ...	38.10	42.52	44.45	41.12	40.12	18.97
	64	15 2 . 064 2601 ...	39.37	43.79	45.72	42.39	41.39	18.97
	66	15 2 . 066 2601 ...	40.64	45.06	46.99	43.66	42.66	20.24
	68	15 2 . 068 2601 ...	41.91	46.33	48.26	44.93	43.93	20.24
	70	15 2 . 070 2601 ...	43.18	47.60	49.53	46.20	45.20	21.51
	72	15 2 . 072 2601 ...	44.45	48.87	50.80	47.47	46.47	21.51
	74	15 2 . 074 2601 ...	45.72	50.14	52.07	48.74	47.74	22.78
	76	15 2 . 076 2601 ...	46.99	51.41	53.34	50.01	49.01	22.78
	78	15 2 . 078 2601 ...	48.26	52.68	54.61	51.28	50.28	24.05
	80	15 2 . 080 2601 ...	49.53	53.95	55.88	52.55	51.55	24.05
	82	15 2 . 082 2601 ...	50.80	55.22	57.15	53.82	52.82	25.32
	84	15 2 . 084 2601 ...	52.07	56.49	58.42	55.09	54.09	25.32
	86	15 2 . 086 2601 ...	53.34	57.76	59.69	56.36	55.36	26.59
	88	15 2 . 088 2601 ...	54.61	59.03	60.96	57.63	56.63	26.59
	90	15 2 . 090 2601 ...	55.88	60.30	62.23	58.90	57.90	27.86
	92	15 2 . 092 2601 ...	57.15	61.57	63.50	60.17	59.17	27.86
	94	15 2 . 094 2601 ...	58.42	62.84	64.77	61.44	60.44	29.13
	96	15 2 . 096 2601 ...	59.69	64.11	66.04	62.71	61.71	29.13
	98	15 2 . 098 2601 ...	60.96	65.38	67.31	63.98	62.98	30.40
	100	15 2 . 100 2601 ...	62.23	66.65	68.58	65.25	64.25	30.40

Please insert digit for stacking height

- 6.25 mm ► 1
- 9.05 mm ► 2
- 13.65 mm ► 3

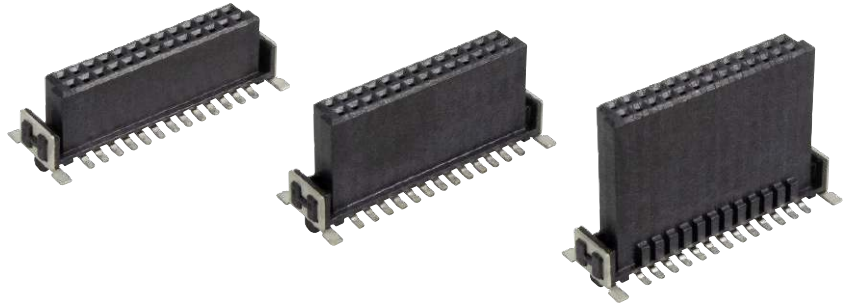

Female connectors, straight, SMT

Identification

Drawing

Dimensions in mm

Dimensions

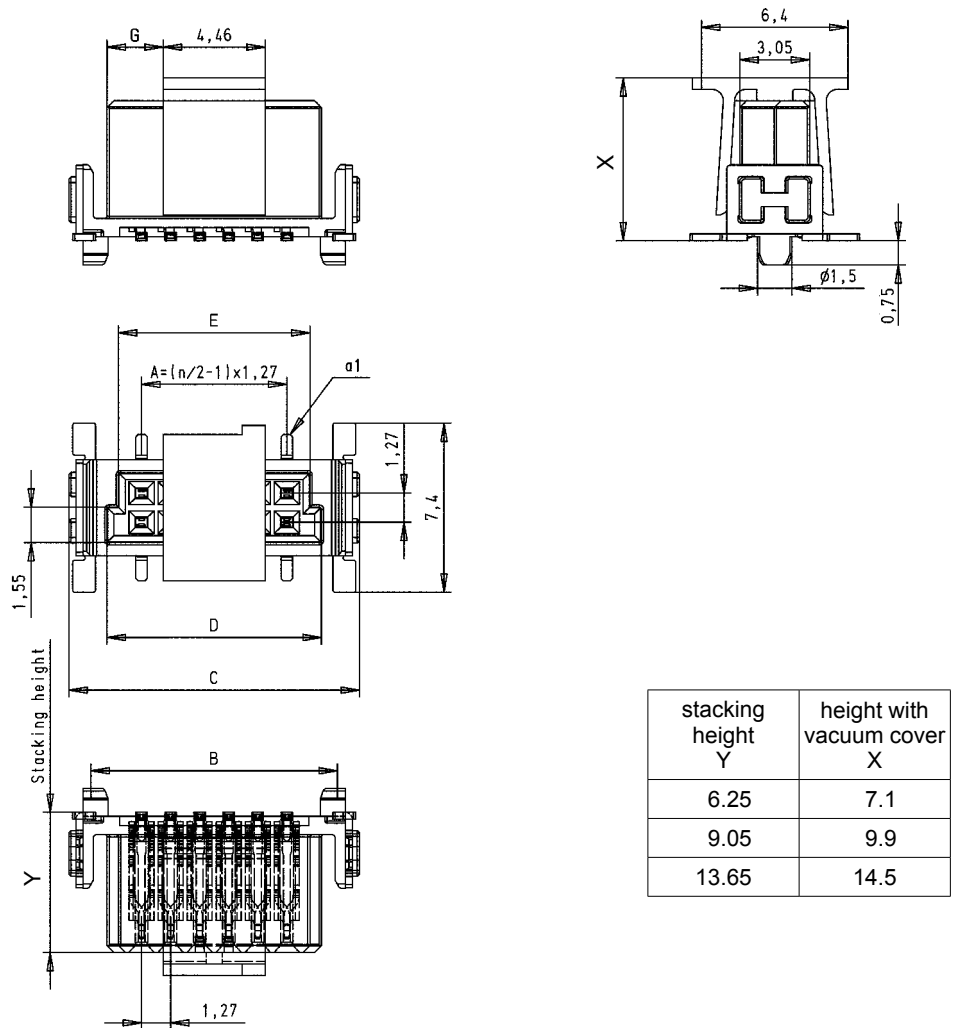

PCB layout

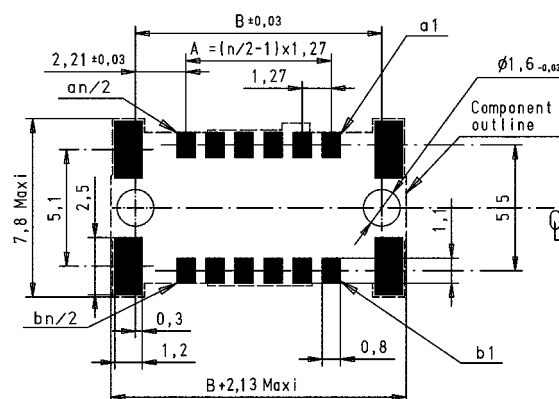

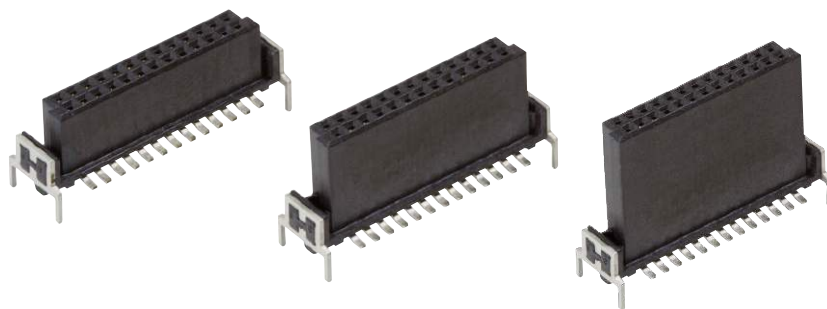

Female connectors, straight, THR

Identification	No. of contacts	Part number	Dimensions in mm					
			A	B	C	D	E	G
Female connector, straight, THR stacking heights 6.25 / 9.05 / 13.65 mm	6	15 2 . 006 2401 ...	2.54	6.96	8.89	5.56	4.56	1.19
	8	15 2 . 008 2401 ...	3.81	8.23	10.16	6.83	5.83	1.19
	10	15 2 . 010 2401 ...	5.08	9.50	11.43	8.10	7.10	2.46
	12	15 2 . 012 2401 ...	6.35	10.77	12.70	9.37	8.37	2.46
	14	15 2 . 014 2401 ...	7.62	12.04	13.97	10.64	9.64	3.73
	16	15 2 . 016 2401 ...	8.89	13.31	15.24	11.91	10.91	3.73
	18	15 2 . 018 2401 ...	10.16	14.58	16.51	13.18	12.18	5.00
	20	15 2 . 020 2401 ...	11.43	15.85	17.78	14.45	13.45	5.00
	22	15 2 . 022 2401 ...	12.70	17.12	19.05	15.72	14.72	6.27
	24	15 2 . 024 2401 ...	13.97	18.39	20.32	16.99	15.99	6.27
	26	15 2 . 026 2401 ...	15.24	19.66	21.59	18.26	17.26	7.54
	28	15 2 . 028 2401 ...	16.51	20.93	22.86	19.53	18.53	7.54
	30	15 2 . 030 2401 ...	17.78	22.20	24.13	20.80	19.80	8.81
	32	15 2 . 032 2401 ...	19.05	23.47	25.40	22.07	21.07	8.81
	34	15 2 . 034 2401 ...	20.32	24.74	26.67	23.34	22.34	10.08
	36	15 2 . 036 2401 ...	21.59	26.01	27.94	24.61	23.61	10.08
	38	15 2 . 038 2401 ...	22.86	27.28	29.21	25.88	24.88	11.35
	40	15 2 . 040 2401 ...	24.13	28.55	30.48	27.15	26.15	11.35
	42	15 2 . 042 2401 ...	25.40	29.82	31.75	28.42	27.42	12.62
	44	15 2 . 044 2401 ...	26.67	31.09	33.02	29.69	28.69	12.62
	46	15 2 . 046 2401 ...	27.94	32.36	34.29	30.96	29.96	13.89
	48	15 2 . 048 2401 ...	29.21	33.63	35.56	32.23	31.23	13.89
	50	15 2 . 050 2401 ...	30.48	34.90	36.83	33.50	32.50	15.16
	52	15 2 . 052 2401 ...	31.75	36.17	38.10	34.77	33.77	15.16
	54	15 2 . 054 2401 ...	33.02	37.44	39.37	36.04	35.04	16.43
	56	15 2 . 056 2401 ...	34.29	38.71	40.64	37.31	36.31	16.43
	58	15 2 . 058 2401 ...	35.56	39.98	41.91	38.58	37.58	17.70
	60	15 2 . 060 2401 ...	36.83	41.25	43.18	39.85	38.85	17.70
	62	15 2 . 062 2401 ...	38.10	42.52	44.45	41.12	40.12	18.97
	64	15 2 . 064 2401 ...	39.37	43.79	45.72	42.39	41.39	18.97
	66	15 2 . 066 2401 ...	40.64	45.06	46.99	43.66	42.66	20.24
	68	15 2 . 068 2401 ...	41.91	46.33	48.26	44.93	43.93	20.24
	70	15 2 . 070 2401 ...	43.18	47.60	49.53	46.20	45.20	21.51
	72	15 2 . 072 2401 ...	44.45	48.87	50.80	47.47	46.47	21.51
	74	15 2 . 074 2401 ...	45.72	50.14	52.07	48.74	47.74	22.78
	76	15 2 . 076 2401 ...	46.99	51.41	53.34	50.01	49.01	22.78
	78	15 2 . 078 2401 ...	48.26	52.68	54.61	51.28	50.28	24.05
	80	15 2 . 080 2401 ...	49.53	53.95	55.88	52.55	51.55	24.05
	82	15 2 . 082 2401 ...	50.80	55.22	57.15	53.82	52.82	25.32
	84	15 2 . 084 2401 ...	52.07	56.49	58.42	55.09	54.09	25.32
	86	15 2 . 086 2401 ...	53.34	57.76	59.69	56.36	55.36	26.59
	88	15 2 . 088 2401 ...	54.61	59.03	60.96	57.63	56.63	26.59
	90	15 2 . 090 2401 ...	55.88	60.30	62.23	58.90	57.90	27.86
	92	15 2 . 092 2401 ...	57.15	61.57	63.50	60.17	59.17	27.86
	94	15 2 . 094 2401 ...	58.42	62.84	64.77	61.44	60.44	29.13
	96	15 2 . 096 2401 ...	59.69	64.11	66.04	62.71	61.71	29.13
	98	15 2 . 098 2401 ...	60.96	65.38	67.31	63.98	62.98	30.40
	100	15 2 . 100 2401 ...	62.23	66.65	68.58	65.25	64.25	30.40

Please insert digit for stacking height

- 6.25 mm ► 1
- 9.05 mm ► 2
- 13.65 mm ► 3

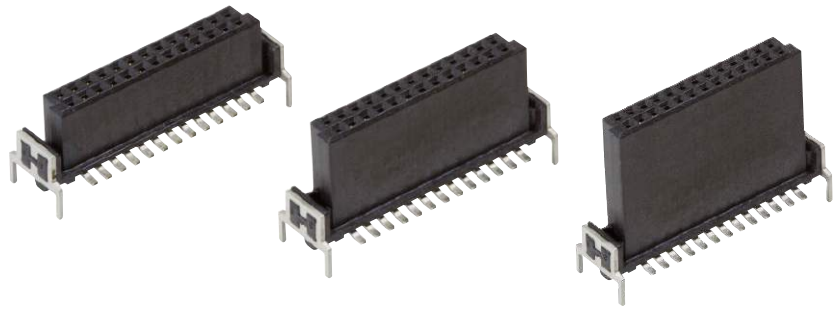

Female connectors, straight, THR

Identification

Drawing

Dimensions in mm

Dimensions

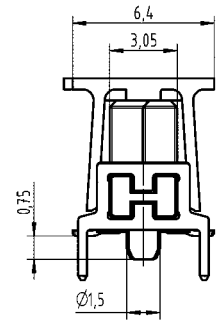
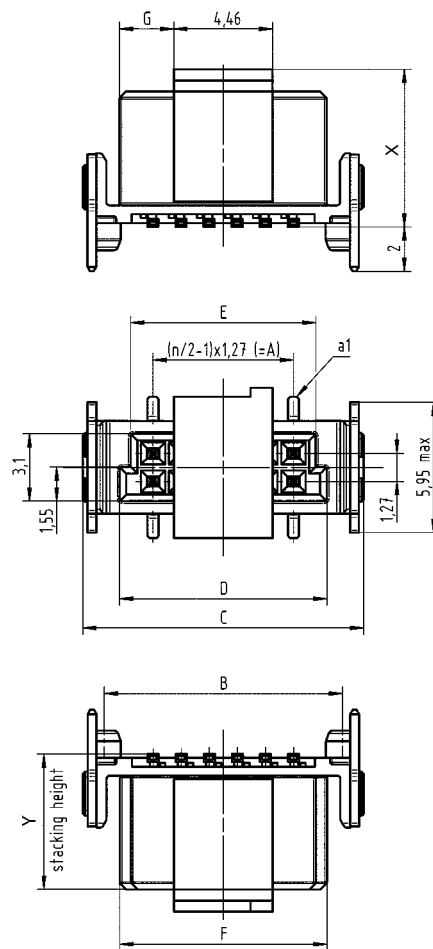

stacking height Y	height with vacuum cover X
6.25	7.1
9.05	9.9
13.65	14.5

PCB layout

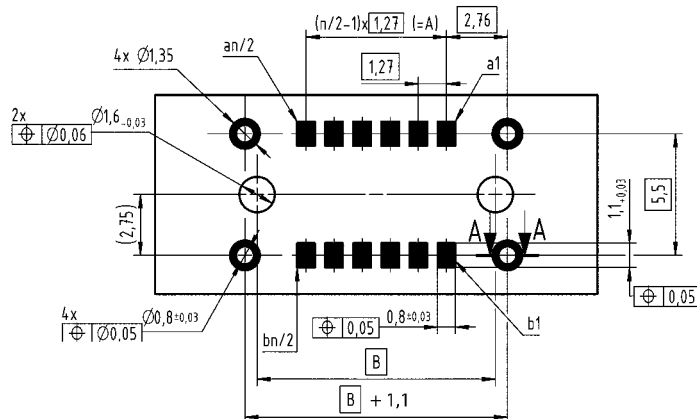



Male connectors, angled, SMT

Identification	No. of contacts	Part number	Dimensions in mm				
			A	B	C	D	E
Male connector, angled, SMT	6	15 15 006 2601 ...	2.54	6.96	8.89	5.76	4.76
	8	15 15 008 2601 ...	3.81	8.23	10.16	7.03	6.03
	10	15 15 010 2601 ...	5.08	9.50	11.43	8.30	7.30
	12	15 15 012 2601 ...	6.35	10.77	12.70	9.57	8.57
	14	15 15 014 2601 ...	7.62	12.04	13.97	10.84	9.84
	16	15 15 016 2601 ...	8.89	13.31	15.24	12.11	11.11
	18	15 15 018 2601 ...	10.16	14.58	16.51	13.38	12.38
	20	15 15 020 2601 ...	11.43	15.85	17.78	14.65	13.65
	22	15 15 022 2601 ...	12.70	17.12	19.05	15.92	14.92
	24	15 15 024 2601 ...	13.97	18.39	20.32	17.19	16.19
	26	15 15 026 2601 ...	15.24	19.66	21.59	18.46	17.46
	28	15 15 028 2601 ...	16.51	20.93	22.86	19.73	18.73
	30	15 15 030 2601 ...	17.78	22.20	24.13	21.00	20.00
	32	15 15 032 2601 ...	19.05	23.47	25.40	22.27	21.27
	34	15 15 034 2601 ...	20.32	24.74	26.67	23.54	22.54
	36	15 15 036 2601 ...	21.59	26.01	27.94	24.81	23.81
	38	15 15 038 2601 ...	22.86	27.28	29.21	26.08	25.08
	40	15 15 040 2601 ...	24.13	28.55	30.48	27.35	26.35
	42	15 15 042 2601 ...	25.40	29.82	31.75	28.62	27.62
	44	15 15 044 2601 ...	26.67	31.09	33.02	29.89	28.89
	46	15 15 046 2601 ...	27.94	32.36	34.29	31.16	30.16
	48	15 15 048 2601 ...	29.21	33.63	35.56	32.43	31.43
	50	15 15 050 2601 ...	30.48	34.90	36.83	33.70	32.70
	52	15 15 052 2601 ...	31.75	36.17	38.10	34.97	33.97
	54	15 15 054 2601 ...	33.02	37.44	39.37	36.24	35.24
	56	15 15 056 2601 ...	34.29	38.71	40.64	37.51	36.51
	58	15 15 058 2601 ...	35.56	39.98	41.91	38.78	37.78
	60	15 15 060 2601 ...	36.83	41.25	43.18	40.05	39.05
62	15 15 062 2601 ...	38.10	42.52	44.45	41.32	40.32	
64	15 15 064 2601 ...	39.37	43.79	45.72	42.59	41.59	
66	15 15 066 2601 ...	40.64	45.06	46.99	43.86	42.86	
68	15 15 068 2601 ...	41.91	46.33	48.26	45.13	44.13	
70	15 15 070 2601 ...	43.18	47.60	49.53	46.40	45.40	
72	15 15 072 2601 ...	44.45	48.87	50.80	47.67	46.67	
74	15 15 074 2601 ...	45.72	50.14	52.07	48.94	47.94	
76	15 15 076 2601 ...	46.99	51.41	53.34	50.21	49.21	
78	15 15 078 2601 ...	48.26	52.68	54.61	51.48	50.48	
80	15 15 080 2601 ...	49.53	53.95	55.88	52.75	51.75	
82	15 15 082 2601 ...	50.80	55.22	57.15	54.02	53.02	
84	15 15 084 2601 ...	52.07	56.49	58.42	55.29	54.29	
86	15 15 086 2601 ...	53.34	57.76	59.69	56.56	55.56	
88	15 15 088 2601 ...	54.61	59.03	60.96	57.83	56.83	
90	15 15 090 2601 ...	55.88	60.30	62.23	59.10	58.10	
92	15 15 092 2601 ...	57.15	61.57	63.50	60.37	59.37	
94	15 15 094 2601 ...	58.42	62.84	64.77	61.64	60.64	
96	15 15 096 2601 ...	59.69	64.11	66.04	62.91	61.91	
98	15 15 098 2601 ...	60.96	65.38	67.31	64.18	63.18	
100	15 15 100 2601 ...	62.23	66.65	68.58	65.45	64.45	

har-flex



Male connectors, angled, SMT

Identification

Drawing

Dimensions in mm

Dimensions

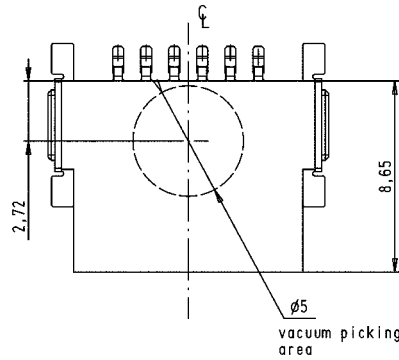
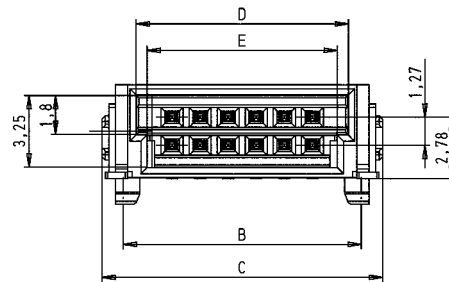
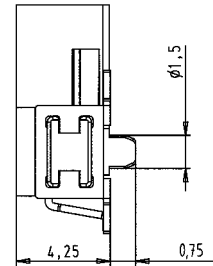
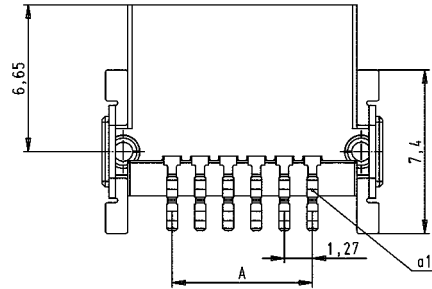

PCB layout

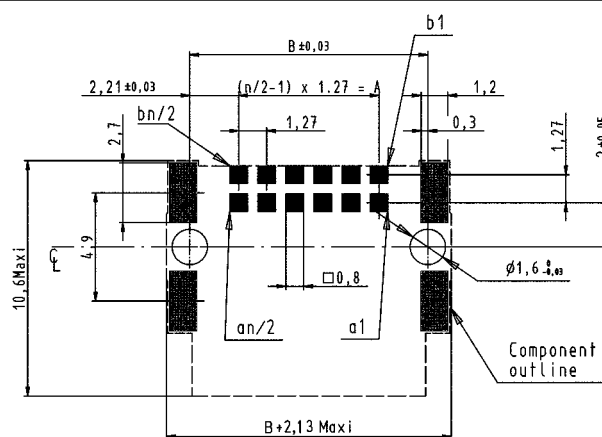

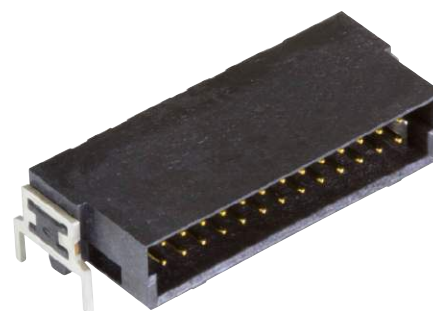

Male connectors, angled, THR

Identification	No. of contacts	Part number	Dimensions in mm				
			A	B	C	D	E
Male connector, angled, THR	6	15 15 006 2401 ...	2.54	6.96	8.89	5.76	4.76
	8	15 15 008 2401 ...	3.81	8.23	10.16	7.03	6.03
	10	15 15 010 2401 ...	5.08	9.50	11.43	8.30	7.30
	12	15 15 012 2401 ...	6.35	10.77	12.70	9.57	8.57
	14	15 15 014 2401 ...	7.62	12.04	13.97	10.84	9.84
	16	15 15 016 2401 ...	8.89	13.31	15.24	12.11	11.11
	18	15 15 018 2401 ...	10.16	14.58	16.51	13.38	12.38
	20	15 15 020 2401 ...	11.43	15.85	17.78	14.65	13.65
	22	15 15 022 2401 ...	12.70	17.12	19.05	15.92	14.92
	24	15 15 024 2401 ...	13.97	18.39	20.32	17.19	16.19
	26	15 15 026 2401 ...	15.24	19.66	21.59	18.46	17.46
	28	15 15 028 2401 ...	16.51	20.93	22.86	19.73	18.73
	30	15 15 030 2401 ...	17.78	22.20	24.13	21.00	20.00
	32	15 15 032 2401 ...	19.05	23.47	25.40	22.27	21.27
	34	15 15 034 2401 ...	20.32	24.74	26.67	23.54	22.54
	36	15 15 036 2401 ...	21.59	26.01	27.94	24.81	23.81
	38	15 15 038 2401 ...	22.86	27.28	29.21	26.08	25.08
	40	15 15 040 2401 ...	24.13	28.55	30.48	27.35	26.35
	42	15 15 042 2401 ...	25.40	29.82	31.75	28.62	27.62
	44	15 15 044 2401 ...	26.67	31.09	33.02	29.89	28.89
	46	15 15 046 2401 ...	27.94	32.36	34.29	31.16	30.16
	48	15 15 048 2401 ...	29.21	33.63	35.56	32.43	31.43
	50	15 15 050 2401 ...	30.48	34.90	36.83	33.70	32.70
	52	15 15 052 2401 ...	31.75	36.17	38.10	34.97	33.97
	54	15 15 054 2401 ...	33.02	37.44	39.37	36.24	35.24
	56	15 15 056 2401 ...	34.29	38.71	40.64	37.51	36.51
	58	15 15 058 2401 ...	35.56	39.98	41.91	38.78	37.78
	60	15 15 060 2401 ...	36.83	41.25	43.18	40.05	39.05
62	15 15 062 2401 ...	38.10	42.52	44.45	41.32	40.32	
64	15 15 064 2401 ...	39.37	43.79	45.72	42.59	41.59	
66	15 15 066 2401 ...	40.64	45.06	46.99	43.86	42.86	
68	15 15 068 2401 ...	41.91	46.33	48.26	45.13	44.13	
70	15 15 070 2401 ...	43.18	47.60	49.53	46.40	45.40	
72	15 15 072 2401 ...	44.45	48.87	50.80	47.67	46.67	
74	15 15 074 2401 ...	45.72	50.14	52.07	48.94	47.94	
76	15 15 076 2401 ...	46.99	51.41	53.34	50.21	49.21	
78	15 15 078 2401 ...	48.26	52.68	54.61	51.48	50.48	
80	15 15 080 2401 ...	49.53	53.95	55.88	52.75	51.75	
82	15 15 082 2401 ...	50.80	55.22	57.15	54.02	53.02	
84	15 15 084 2401 ...	52.07	56.49	58.42	55.29	54.29	
86	15 15 086 2401 ...	53.34	57.76	59.69	56.56	55.56	
88	15 15 088 2401 ...	54.61	59.03	60.96	57.83	56.83	
90	15 15 090 2401 ...	55.88	60.30	62.23	59.10	58.10	
92	15 15 092 2401 ...	57.15	61.57	63.50	60.37	59.37	
94	15 15 094 2401 ...	58.42	62.84	64.77	61.64	60.64	
96	15 15 096 2401 ...	59.69	64.11	66.04	62.91	61.91	
98	15 15 098 2401 ...	60.96	65.38	67.31	64.18	63.18	
100	15 15 100 2401 ...	62.23	66.65	68.58	65.45	64.45	

har-flex

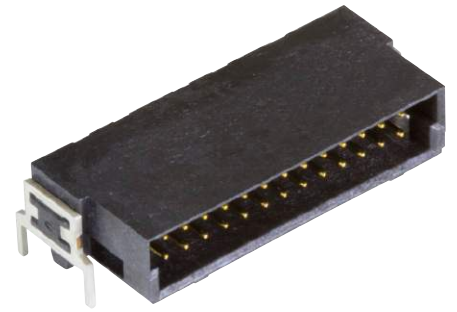

Male connectors, angled, THR

Identification

Drawing

Dimensions in mm

Dimensions

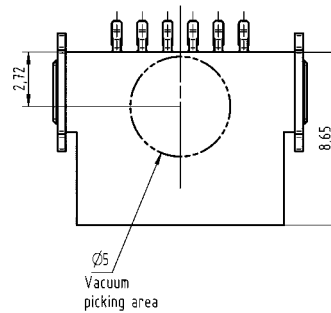
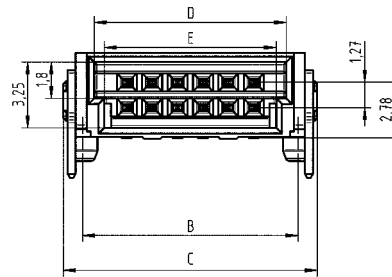
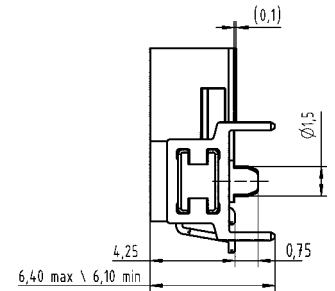
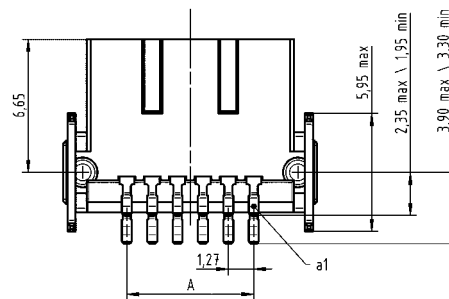

PCB layout

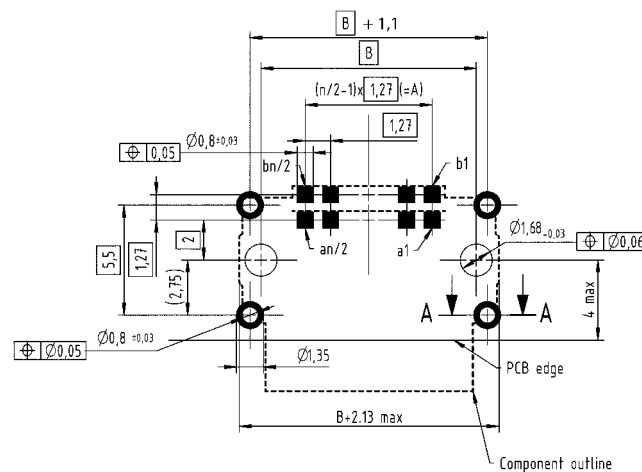



Female connectors, angled, SMT

Identification	No. of contacts	Part number	Dimensions in mm				
			A	B	C	D	E
Female connector, angled, SMT	6	15 25 006 2601 ...	2.54	6.96	8.89	5.56	4.56
	8	15 25 008 2601 ...	3.81	8.23	10.16	6.83	5.83
	10	15 25 010 2601 ...	5.08	9.50	11.43	8.10	7.10
	12	15 25 012 2601 ...	6.35	10.77	12.70	9.37	8.37
	14	15 25 014 2601 ...	7.62	12.04	13.97	10.64	9.64
	16	15 25 016 2601 ...	8.89	13.31	15.24	11.91	10.91
	18	15 25 018 2601 ...	10.16	14.58	16.51	13.18	12.18
	20	15 25 020 2601 ...	11.43	15.85	17.78	14.45	13.45
	22	15 25 022 2601 ...	12.70	17.12	19.05	15.72	14.72
	24	15 25 024 2601 ...	13.97	18.39	20.32	16.99	15.99
	26	15 25 026 2601 ...	15.24	19.66	21.59	18.26	17.26
	28	15 25 028 2601 ...	16.51	20.93	22.86	19.53	18.53
	30	15 25 030 2601 ...	17.78	22.20	24.13	20.80	19.80
	32	15 25 032 2601 ...	19.05	23.47	25.40	22.07	21.07
	34	15 25 034 2601 ...	20.32	24.74	26.67	23.34	22.34
	36	15 25 036 2601 ...	21.59	26.01	27.94	24.61	23.61
	38	15 25 038 2601 ...	22.86	27.28	29.21	25.88	24.88
	40	15 25 040 2601 ...	24.13	28.55	30.48	27.15	26.15
	42	15 25 042 2601 ...	25.40	29.82	31.75	28.42	27.42
	44	15 25 044 2601 ...	26.67	31.09	33.02	29.69	28.69
	46	15 25 046 2601 ...	27.94	32.36	34.29	30.96	29.96
	48	15 25 048 2601 ...	29.21	33.63	35.56	32.23	31.23
	50	15 25 050 2601 ...	30.48	34.90	36.83	33.50	32.50
	52	15 25 052 2601 ...	31.75	36.17	38.10	34.77	33.77
	54	15 25 054 2601 ...	33.02	37.44	39.37	36.04	35.04
	56	15 25 056 2601 ...	34.29	38.71	40.64	37.31	36.31
	58	15 25 058 2601 ...	35.56	39.98	41.91	38.58	37.58
	60	15 25 060 2601 ...	36.83	41.25	43.18	39.85	38.85
62	15 25 062 2601 ...	38.10	42.52	44.45	41.12	40.12	
64	15 25 064 2601 ...	39.37	43.79	45.72	42.39	41.39	
66	15 25 066 2601 ...	40.64	45.06	46.99	43.66	42.66	
68	15 25 068 2601 ...	41.91	46.33	48.26	44.93	43.93	
70	15 25 070 2601 ...	43.18	47.60	49.53	46.20	45.20	
72	15 25 072 2601 ...	44.45	48.87	50.80	47.47	46.47	
74	15 25 074 2601 ...	45.72	50.14	52.07	48.74	47.74	
76	15 25 076 2601 ...	46.99	51.41	53.34	50.01	49.01	
78	15 25 078 2601 ...	48.26	52.68	54.61	51.28	50.28	
80	15 25 080 2601 ...	49.53	53.95	55.88	52.55	51.55	
82	15 25 082 2601 ...	50.80	55.22	57.15	53.82	52.82	
84	15 25 084 2601 ...	52.07	56.49	58.42	55.09	54.09	
86	15 25 086 2601 ...	53.34	57.76	59.69	56.36	55.36	
88	15 25 088 2601 ...	54.61	59.03	60.96	57.63	56.63	
90	15 25 090 2601 ...	55.88	60.30	62.23	58.90	57.90	
92	15 25 092 2601 ...	57.15	61.57	63.50	60.17	59.17	
94	15 25 094 2601 ...	58.42	62.84	64.77	61.44	60.44	
96	15 25 096 2601 ...	59.69	64.11	66.04	62.71	61.71	
98	15 25 098 2601 ...	60.96	65.38	67.31	63.98	62.98	
100	15 25 100 2601 ...	62.23	66.65	68.58	65.25	64.25	

har:lex



Female connectors, angled, SMT

Identification

Drawing

Dimensions in mm

Dimensions

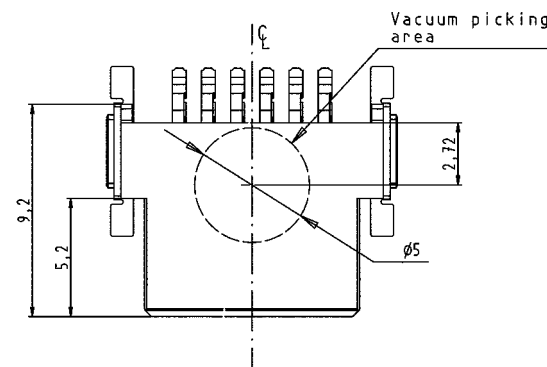
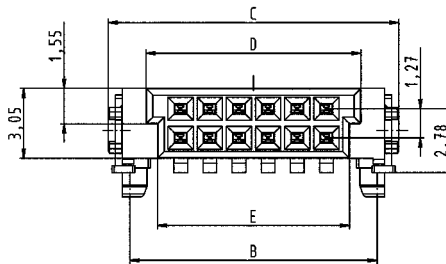
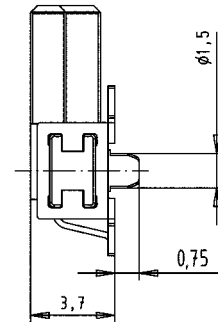
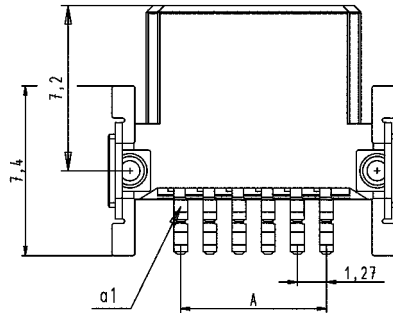

PCB layout

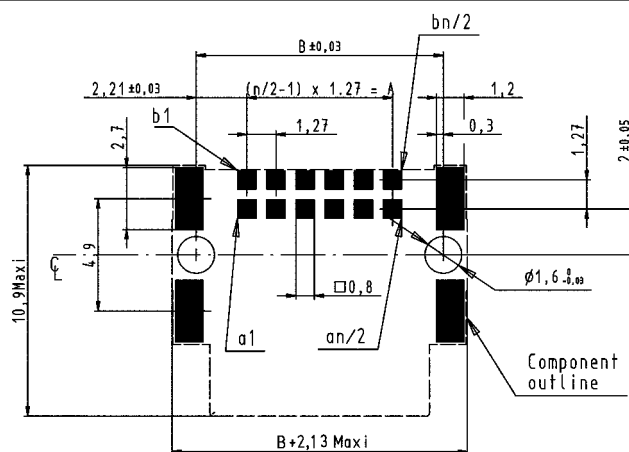



Female connectors, IDC

Identification	Number of contacts	Part No.	Dimensions in mm				
			A	B	C	D	E
Female connector, IDC in a tray packaging	6	15 29 006 250 . 000	2.54	11.59	5.56	4.56	15.00
	8	15 29 008 250 . 000	3.81	12.86	6.83	5.83	15.00
	10	15 29 010 250 . 000	5.08	14.13	8.10	7.10	15.00
	12	15 29 012 250 . 000	6.35	15.40	9.37	8.37	15.00
	14	15 29 014 250 . 000	7.62	16.67	10.64	9.64	15.00
	16	15 29 016 250 . 000	8.89	17.94	11.91	10.91	15.00
	18	15 29 018 250 . 000	10.16	19.21	13.18	12.18	15.00
	20	15 29 020 250 . 000	11.43	20.48	14.45	13.45	15.00
	22	15 29 022 250 . 000	12.70	21.75	15.72	14.72	15.00
	24	15 29 024 250 . 000	13.97	23.02	16.99	15.99	15.00
	26	15 29 026 250 . 000	15.24	24.29	18.26	17.26	15.00
	28	15 29 028 250 . 000	16.51	25.56	19.53	18.53	15.00
	30	15 29 030 250 . 000	17.78	26.83	20.80	19.80	15.00
	32	15 29 032 250 . 000	19.05	28.10	22.07	21.07	15.00
	34	15 29 034 250 . 000	20.32	29.37	23.34	22.34	15.00
	36	15 29 036 250 . 000	21.59	30.64	24.61	23.61	15.00
	38	15 29 038 250 . 000	22.86	31.91	25.88	24.88	15.00
	40	15 29 040 250 . 000	24.13	33.18	27.15	26.15	15.00
	42	15 29 042 250 . 000	25.40	34.45	28.42	27.42	15.00
	44	15 29 044 250 . 000	26.67	35.72	29.69	28.69	15.00
	46	15 29 046 250 . 000	27.94	36.99	30.96	29.96	15.00
	48	15 29 048 250 . 000	29.21	38.26	32.23	31.23	15.00
	50	15 29 050 250 . 000	30.48	39.53	33.50	32.50	15.00
	52	15 29 052 250 . 000	31.75	40.80	34.77	33.77	15.00
	54	15 29 054 250 . 000	33.02	42.07	36.04	35.04	15.00
	56	15 29 056 250 . 000	34.29	43.34	37.31	36.31	15.00
	58	15 29 058 250 . 000	35.56	44.61	38.58	37.58	15.00
	60	15 29 060 250 . 000	36.83	45.88	39.85	38.85	16.20
	62	15 29 062 250 . 000	38.10	47.15	41.12	40.12	16.20
	64	15 29 064 250 . 000	39.37	48.42	42.39	41.39	16.20
	66	15 29 066 250 . 000	40.64	49.69	43.66	42.66	16.20
	68	15 29 068 250 . 000	41.91	50.96	44.93	43.93	16.20
	70	15 29 070 250 . 000	43.18	52.23	46.20	45.20	16.20
	72	15 29 072 250 . 000	44.45	53.50	47.47	46.47	16.20
	74	15 29 074 250 . 000	45.72	54.77	48.74	47.74	16.20
	76	15 29 076 250 . 000	46.99	56.04	50.01	49.01	16.20
78	15 29 078 250 . 000	48.26	57.31	51.28	50.28	16.20	
80	15 29 080 250 . 000	49.53	58.58	52.55	51.55	16.20	
82	15 29 082 250 . 000	50.80	59.85	53.82	52.82	16.20	
84	15 29 084 250 . 000	52.07	61.12	55.09	54.09	16.20	
86	15 29 086 250 . 000	53.34	62.39	56.36	55.36	16.20	
88	15 29 088 250 . 000	54.61	63.66	57.63	56.63	16.20	
90	15 29 090 250 . 000	55.88	64.93	58.90	57.90	16.20	
92	15 29 092 250 . 000	57.15	66.20	60.17	59.17	16.20	
94	15 29 094 250 . 000	58.42	67.47	61.44	60.44	16.20	
96	15 29 096 250 . 000	59.69	68.74	62.71	61.71	16.20	
98	15 29 098 250 . 000	60.96	70.01	63.98	62.98	16.20	
100	15 29 100 250 . 000	62.23	71.28	65.25	64.25	16.20	

har-flex



Female connectors, IDC

Identification

Drawing

Dimensions in mm

Dimensions

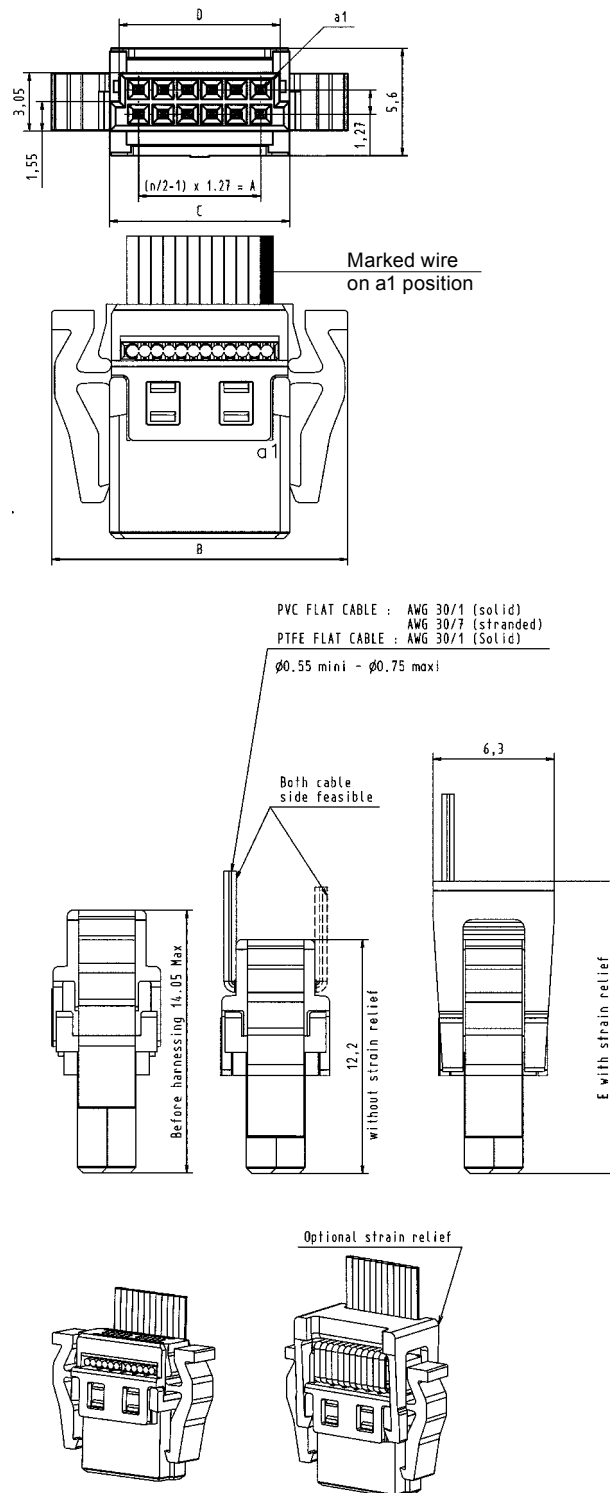



Strain reliefs for female connectors,
IDC

Identification	Number of contacts	Part No.	Dimensions in mm
Strain reliefs for female connectors, IDC	6	15 29 006 0503 000	A
	8	15 29 008 0503 000	7.31
	10	15 29 010 0503 000	8.58
	12	15 29 012 0503 000	9.85
	14	15 29 014 0503 000	11.12
	16	15 29 016 0503 000	12.39
	18	15 29 018 0503 000	13.66
	20	15 29 020 0503 000	14.93
	22	15 29 022 0503 000	16.20
	24	15 29 024 0503 000	17.47
	26	15 29 026 0503 000	18.74
	28	15 29 028 0503 000	20.01
	30	15 29 030 0503 000	21.28
	32	15 29 032 0503 000	22.55
	34	15 29 034 0503 000	23.82
	36	15 29 036 0503 000	25.09
	38	15 29 038 0503 000	26.36
	40	15 29 040 0503 000	27.63
	42	15 29 042 0503 000	28.90
	44	15 29 044 0503 000	30.17
	46	15 29 046 0503 000	31.44
	48	15 29 048 0503 000	32.71
	50	15 29 050 0503 000	33.98
	52	15 29 052 0503 000	35.25
	54	15 29 054 0503 000	36.52
	56	15 29 056 0503 000	37.79
	58	15 29 058 0503 000	39.06
	60	15 29 060 0503 000	40.33
	62	15 29 062 0503 000	41.60
	64	15 29 064 0503 000	42.87
	66	15 29 066 0503 000	44.14
	68	15 29 068 0503 000	45.41
	70	15 29 070 0503 000	46.68
	72	15 29 072 0503 000	47.95
	74	15 29 074 0503 000	49.22
	76	15 29 076 0503 000	50.49
	78	15 29 078 0503 000	51.76
	80	15 29 080 0503 000	53.03
	82	15 29 082 0503 000	54.30
	84	15 29 084 0503 000	55.57
86	15 29 086 0503 000	56.84	
88	15 29 088 0503 000	58.11	
90	15 29 090 0503 000	59.38	
92	15 29 092 0503 000	60.65	
94	15 29 094 0503 000	61.92	
96	15 29 096 0503 000	63.19	
98	15 29 098 0503 000	64.46	
100	15 29 100 0503 000	65.73	
			67.00



Strain reliefs for female connectors, IDC

Identification

Drawing

Dimensions in mm

Dimensions

6 – 58 contacts

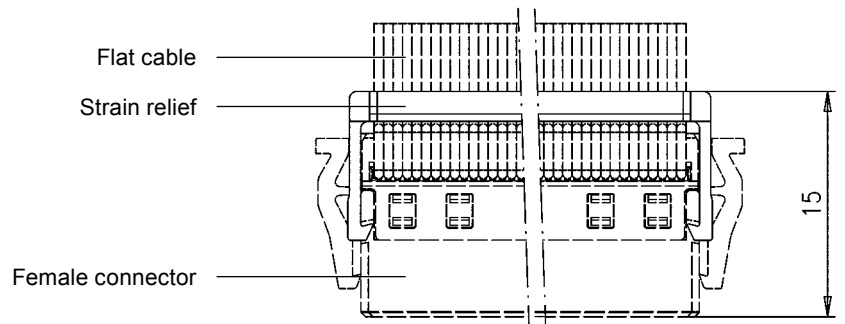
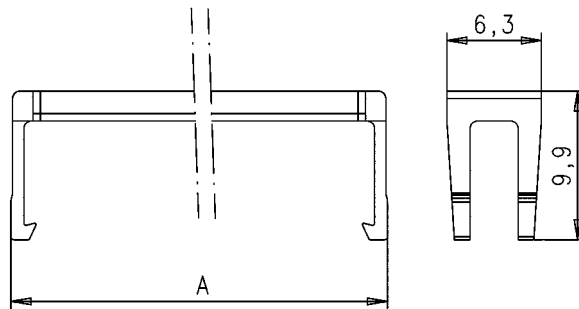

60 – 100 contacts

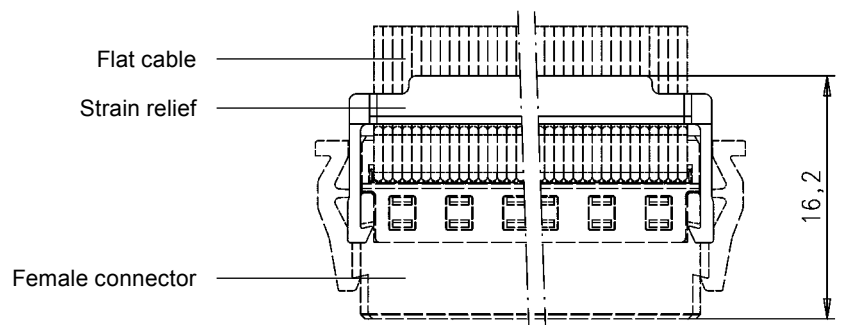
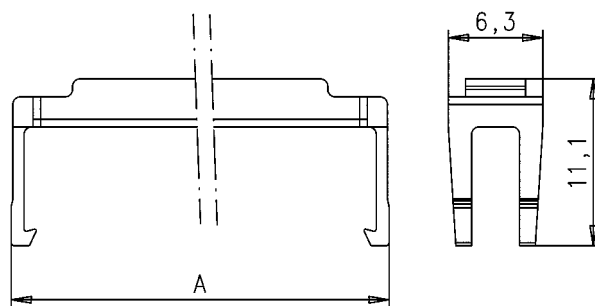

Number of contacts 6, 8, 10 ... 96, 98, 100

Rated voltage 150 V

Core structure AWG 30/7

Strain relief with / without

Connector direction same / different

Wiring 1 : 1 / crossed

Cable types

PVC

Operating temperatures -20 °C ... +105 °C

Halogen free

Operating temperatures -40 °C ... +125 °C

Options

Option 1

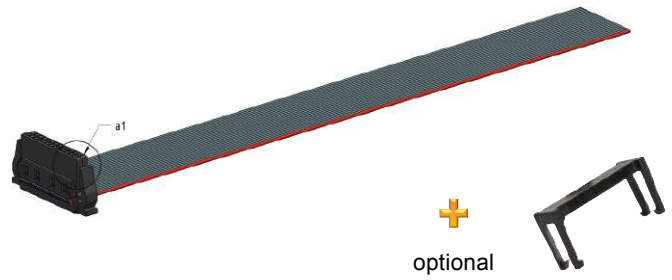

Option 2

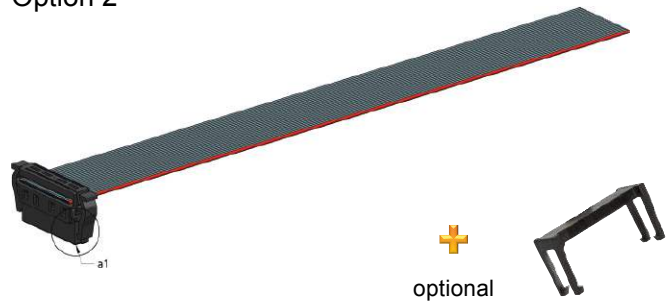

Option 3

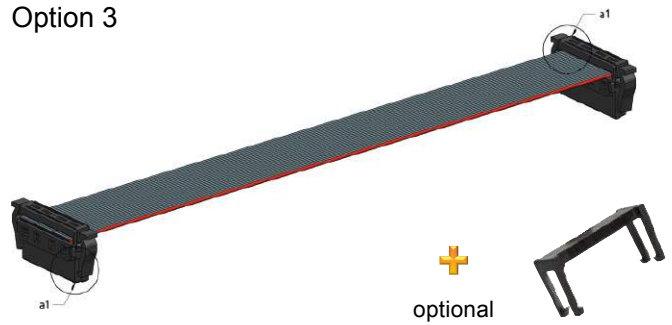

Options

Option 4

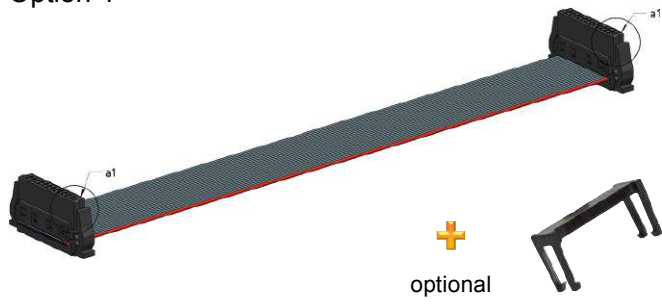

Options

Option 7

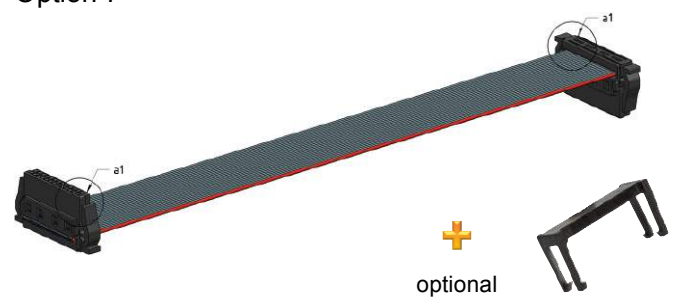

Option 5

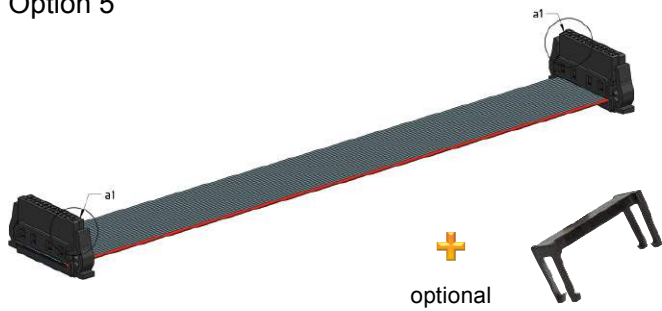

Option 8

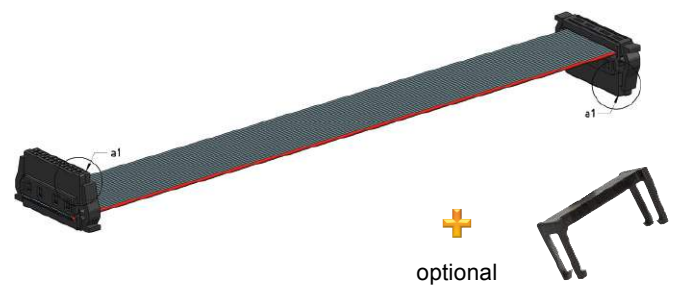

Option 6

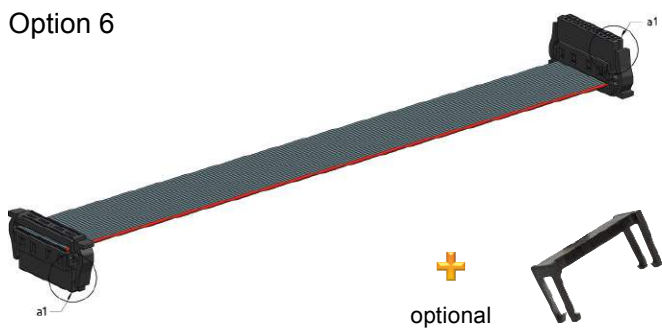

Option 9

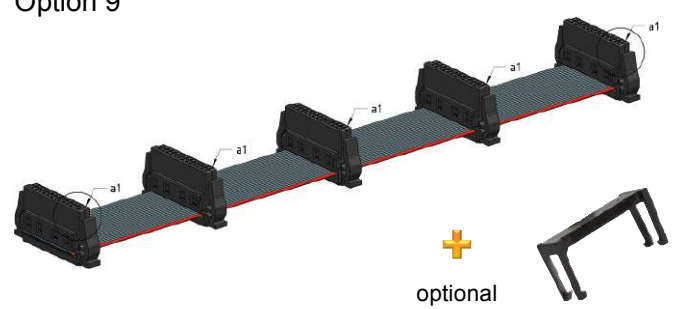



Cable assemblies

Identification	Part number	Drawing	Dimensions in mm
<p>Cable assembly <i>har-flex</i>® and different connector direction</p> <p>Cable: Flat cable PVC, AWG 30/7, 0.635 mm pitch</p> <p>Wiring: 1:1</p>			
<p>Connectors with strain relief</p>			
<p>6 poles Length: L = 0.1 m L = 0.2 m L = 0.5 m</p>	<p>33 15 243 0100 001 33 15 243 0200 002 33 15 243 0500 003</p>		
<p>Connectors without strain relief</p>			
<p>6 poles Length: L = 0.1 m L = 0.2 m L = 0.5 m</p>	<p>33 15 243 0100 373 33 15 243 0200 373 33 15 243 0500 373</p>		
<p>Connectors with strain relief</p>			
<p>12 poles Length: L = 0.1 m L = 0.2 m L = 0.5 m</p>	<p>33 15 243 0100 004 33 15 243 0200 005 33 15 243 0500 006</p>		
<p>Connectors without strain relief</p>			
<p>12 poles Length: L = 0.1 m L = 0.2 m L = 0.5 m</p>	<p>33 15 243 0100 374 33 15 243 0200 374 33 15 243 0500 374</p>		

har-flex

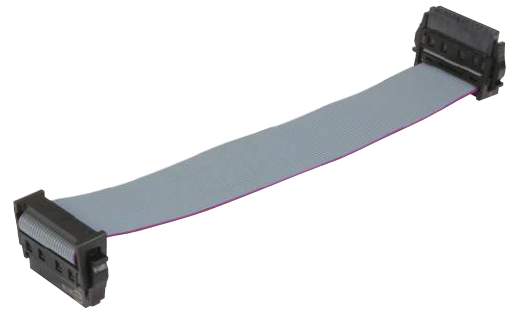

Cable assemblies

Identification	Part number	Drawing	Dimensions in mm
<p>Cable assembly <i>har-flex</i>® and different connector direction</p>			
<p>Cable: Flat cable PVC, AWG 30/7, 0.635 mm pitch Wiring: 1:1</p>			
<p>Connectors with strain relief</p>			
<p>26 poles Length: L = 0.1 m L = 0.2 m L = 0.5 m</p>	<p>33 15 243 0100 007 33 15 243 0200 008 33 15 243 0500 009</p>		
<p>Connectors without strain relief</p>			
<p>26 poles Length: L = 0.1 m L = 0.2 m L = 0.5 m</p>	<p>33 15 243 0100 375 33 15 243 0200 375 33 15 243 0500 375</p>		
<p>Connectors with strain relief</p>			
<p>32 poles Length: L = 0.1 m L = 0.2 m L = 0.5 m</p>	<p>33 15 243 0100 010 33 15 243 0200 011 33 15 243 0500 012</p>		
<p>Connectors without strain relief</p>			
<p>32 poles Length: L = 0.1 m L = 0.2 m L = 0.5 m</p>	<p>33 15 243 0100 376 33 15 243 0200 376 33 15 243 0500 376</p>		



Cable assemblies

Identification	Part number	Drawing	Dimensions in mm
<p>Cable assembly <i>har:flex</i>® and different connector direction</p> <p>Cable: Flat cable PVC, AWG 30/7, 0.635 mm pitch</p> <p>Wiring: 1:1</p>			
<p>Connectors with strain relief</p>	<p>50 poles Length: L = 0.1 m 33 15 243 0100 013 L = 0.2 m 33 15 243 0200 014 L = 0.5 m 33 15 243 0500 015</p>		
<p>Connectors without strain relief</p>	<p>50 poles Length: L = 0.1 m 33 15 243 0100 377 L = 0.2 m 33 15 243 0200 377 L = 0.5 m 33 15 243 0500 377</p>		
<p>Connectors with strain relief</p>	<p>68 poles Length: L = 0.1 m 33 15 243 0100 122 L = 0.2 m 33 15 243 0200 122 L = 0.5 m 33 15 243 0500 122</p>		
<p>Connectors without strain relief</p>	<p>68 poles Length: L = 0.1 m 33 15 243 0100 378 L = 0.2 m 33 15 243 0200 378 L = 0.5 m 33 15 243 0500 378</p>		

har:flex

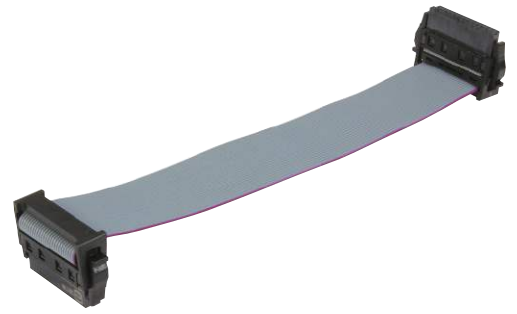

Cable assemblies

Identification	Part number	Drawing	Dimensions in mm
----------------	-------------	---------	------------------

Cable assembly *har-flex*® and different connector direction

Cable: Flat cable PVC, AWG 30/7, 0.635 mm pitch
Wiring: 1:1

Connectors with strain relief

80 poles Length: L = 0.1 m
L = 0.2 m
L = 0.5 m

33 15 243 0100 123
33 15 243 0200 123
33 15 243 0500 123

Connectors without strain relief

80 poles Length: L = 0.1 m
L = 0.2 m
L = 0.5 m

33 15 243 0100 379
33 15 243 0200 379
33 15 243 0500 379

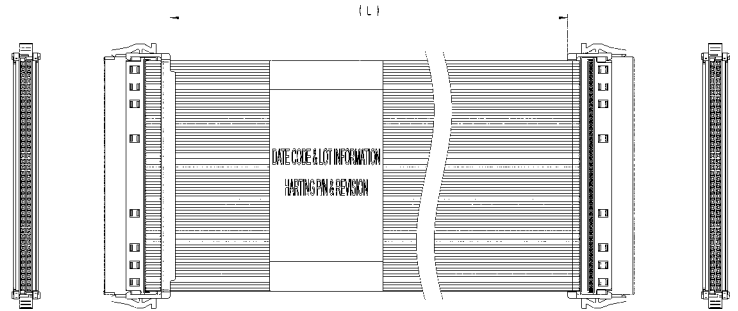



Cable assemblies

Identification	Part number	Drawing	Dimensions in mm
<p>Cable assembly <i>har-flex</i>® and similar connector direction Cable: Flat cable PVC, AWG 30/7, 0.635 mm pitch Wiring: 1:1</p>			
<p>Connectors with strain relief</p>			
<p>6 poles Length: L = 0.1 m L = 0.2 m L = 0.5 m</p>	<p>33 15 243 0100 382 33 15 243 0200 382 33 15 243 0500 382</p>		
<p>Connectors without strain relief</p>			
<p>6 poles Length: L = 0.1 m L = 0.2 m L = 0.5 m</p>	<p>33 15 243 0100 380 33 15 243 0200 380 33 15 243 0500 380</p>		
<p>Connectors with strain relief</p>			
<p>12 poles Length: L = 0.1 m L = 0.2 m L = 0.5 m</p>	<p>33 15 243 0100 102 33 15 243 0200 102 33 15 243 0500 102</p>		
<p>Connectors without strain relief</p>			
<p>12 poles Length: L = 0.1 m L = 0.2 m L = 0.5 m</p>	<p>33 15 243 0100 145 33 15 243 0200 145 33 15 243 0500 145</p>		

har-flex



Cable assemblies

Identification	Part number	Drawing	Dimensions in mm
<p>Cable assembly <i>har-flex</i>® and similar connector direction Cable: Flat cable PVC, AWG 30/7, 0.635 mm pitch Wiring: 1:1</p>			
<p>Connectors with strain relief</p>			
<p>50 poles Length: L = 0.1 m L = 0.2 m L = 0.5 m</p>			
<p>Connectors without strain relief</p>			
<p>50 poles Length: L = 0.1 m L = 0.2 m L = 0.5 m</p>	<p>33 15 243 0100 384 33 15 243 0200 384 33 15 243 0500 384</p>		
<p>Connectors with strain relief</p>			
<p>68 poles Length: L = 0.1 m L = 0.2 m L = 0.5 m</p>			
<p>Connectors without strain relief</p>			
<p>68 poles Length: L = 0.1 m L = 0.2 m L = 0.5 m</p>			
<p>68 poles Length: L = 0.1 m L = 0.2 m L = 0.5 m</p>	<p>33 15 243 0100 148 33 15 243 0200 148 33 15 243 0500 148</p>		

har-flex



Cable assemblies

Identification	Part number	Drawing	Dimensions in mm
----------------	-------------	---------	------------------

Cable assembly *har-flex*® and similar connector direction

Cable: Flat cable PVC,
AWG 30/7, 0.635 mm pitch
Wiring: 1:1

Connectors with strain relief

80 poles Length: L = 0.1 m
L = 0.2 m
L = 0.5 m

33 15 243 0100 386
33 15 243 0200 386
33 15 243 0500 386

Connectors without strain relief

80 poles Length: L = 0.1 m
L = 0.2 m
L = 0.5 m

33 15 243 0100 149
33 15 243 0200 149
33 15 243 0500 149

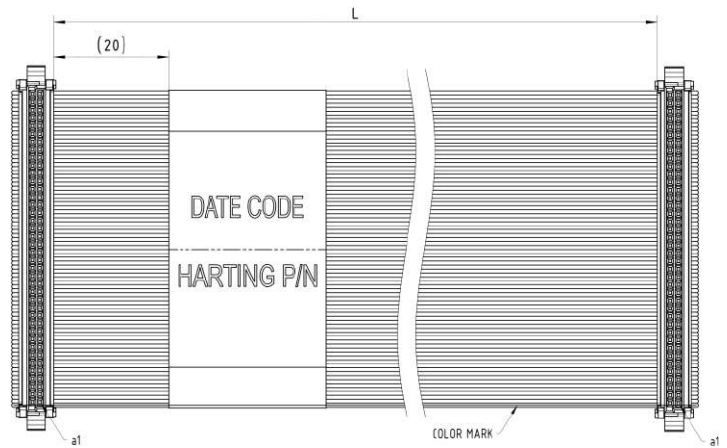

15. har-flexicon® Connectors

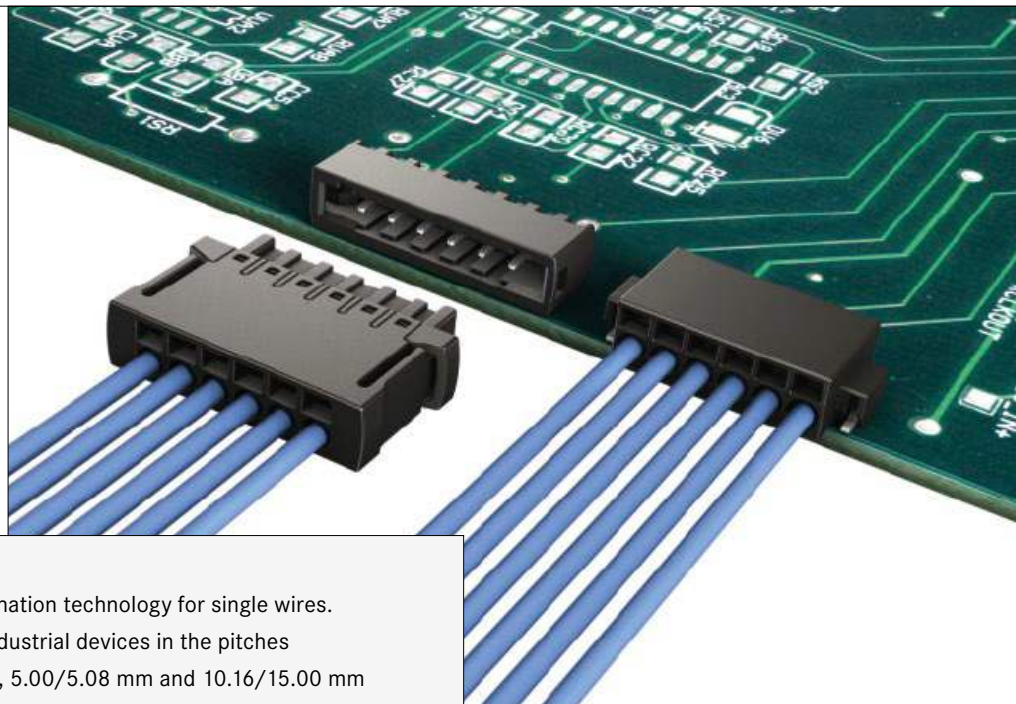

har-flexicon® is the robust PCB termination technology for single wires. Components for the termination of industrial devices in the pitches of 1.27 mm, 2.54 mm, 3.50/3.81 mm, 5.00/5.08 mm and 10.16/15.00 mm are available.

All components are particularly suited for reflow- and wave-soldering on the PCB and offer field assembly with PushIn, insulation displacement and screw termination for single wires.

Application profile:

CONNECTION TYPE		ENVIRONMENT		APPLICATION						
Board to Board	Cable/Wire to Board	IP20	IP65 / IP67	Data	Signal	Power	high performance			
				Data transfer rate	Shielding	Number of contacts, contact density	Voltage, working current			
Cable termination			PCB termination			Application standard				
Han-Quick Lock®	IDC	Crimp	THT	SMC	SMT	SCSI				
Screw	Cage clamp / PushIn	Axial screw	Press-in	Housing integration						
				Separate housing	Integrated housing					

Contents

	Page
<i>har-flexicon</i> ® connector system – introduction	15.02
Pitches 1.27 mm / 2.54 mm	
PCB connectors female with IDC termination	15.04
PCB terminal blocks with push-in-spring-cage termination	15.06
PCB connectors female with push-in-spring-cage termination	15.08
PCB connectors male	15.10
Pitches 3.50 mm / 3.81 mm	
PCB terminal blocks with push-in-spring-cage termination	15.12
PCB terminal blocks with screw termination	15.14
PCB connectors female with push-in-spring-cage termination	15.16
PCB connectors female with screw termination	15.20
PCB connectors male	15.22
Pitches 5.00 mm / 5.08 mm	
PCB terminal blocks with push-in-spring-cage termination	15.28
PCB terminal blocks with screw termination	15.32
PCB connectors female with push-in-spring-cage termination	15.36
PCB connectors female with screw termination	15.40
PCB connectors male	15.42
Pitches 10.16 mm / 15.00 mm	
PCB terminal blocks with screw termination	15.48

har-flexicon® CONNECTORS

Innovative device connectivity technology for all lifelines of industrial devices - it routes power, data and signals through the side of the device to the PCB.

HARTING *har-flexicon*® in the pitches 1.27 mm and 2.54 mm is the miniature SMD connector for the rapid connection of single wires and provides a perfect link between the periphery and PCBs in industrial devices. HARTING is thereby continuing along the path already taken with the *har-flex*® of rethinking and methodically optimizing device connectivity technology.

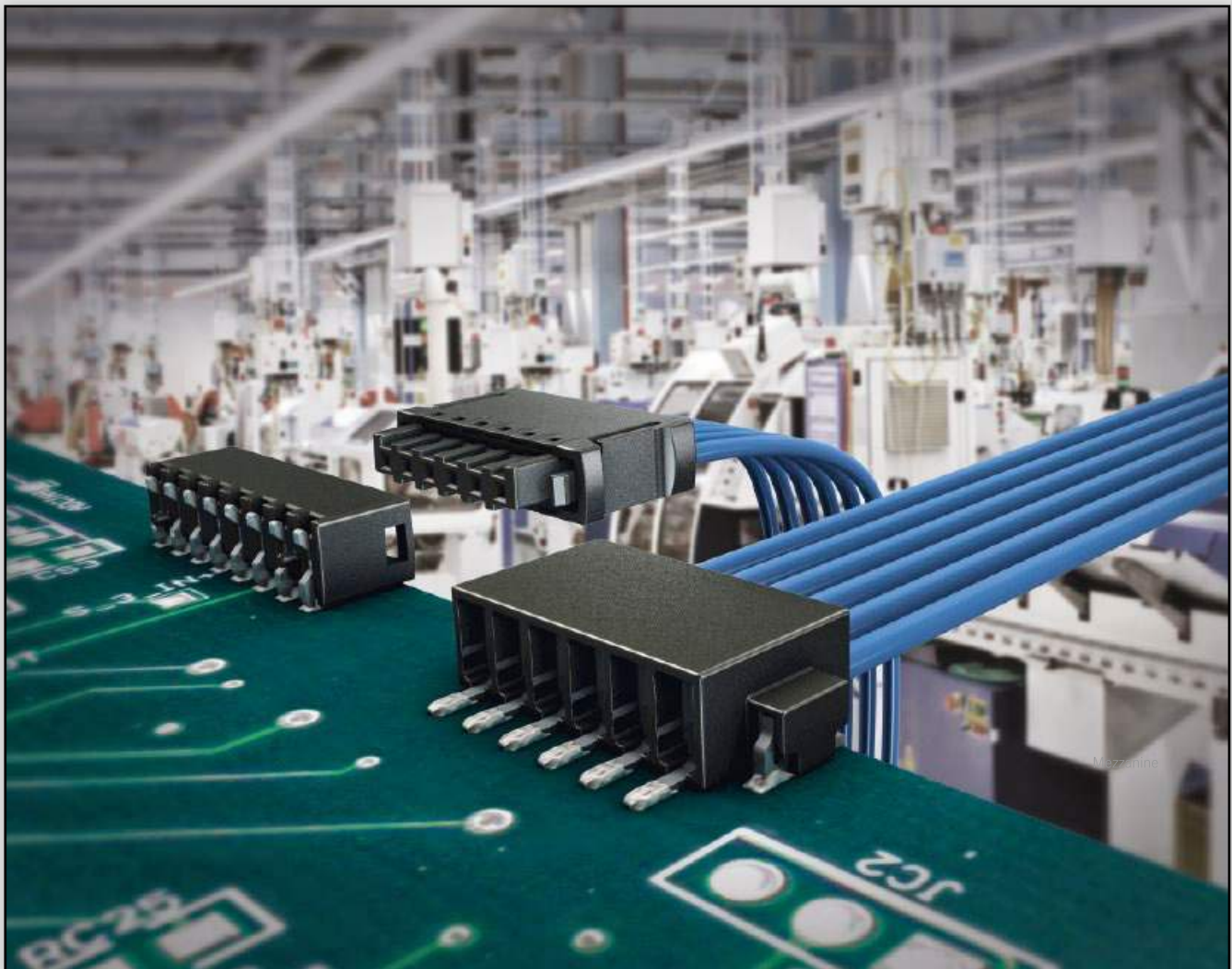

RAPID CONNECTION OF INDIVIDUAL WIRES

har-flexicon® is very easy and quick to use for the smallest of designs. This, in conjunction with a precise cable manager, is what the IDC and the push-in spring-cage termination technology guarantees.

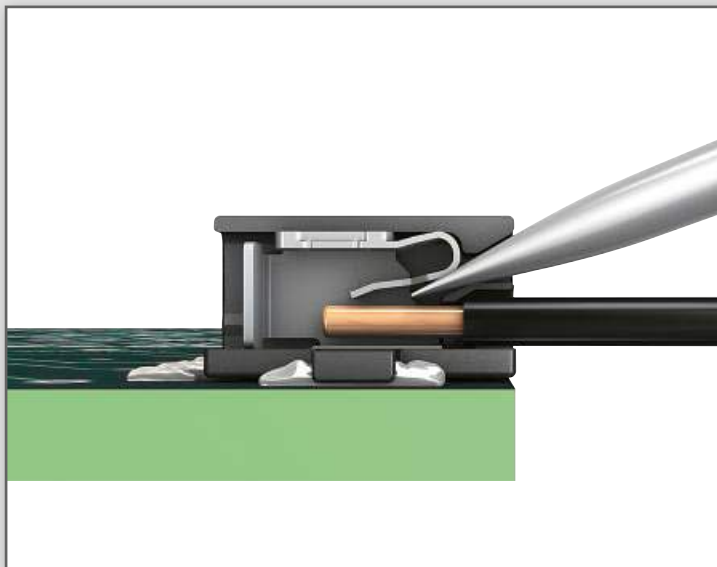

ROBUST SMD DESIGN

The large-area SMT fixings of *har-flexicon*® provide a sturdy connection to the PCB. Insertion and withdrawal forces can be absorbed in order to take the pressure off solder contacts on the connection side.

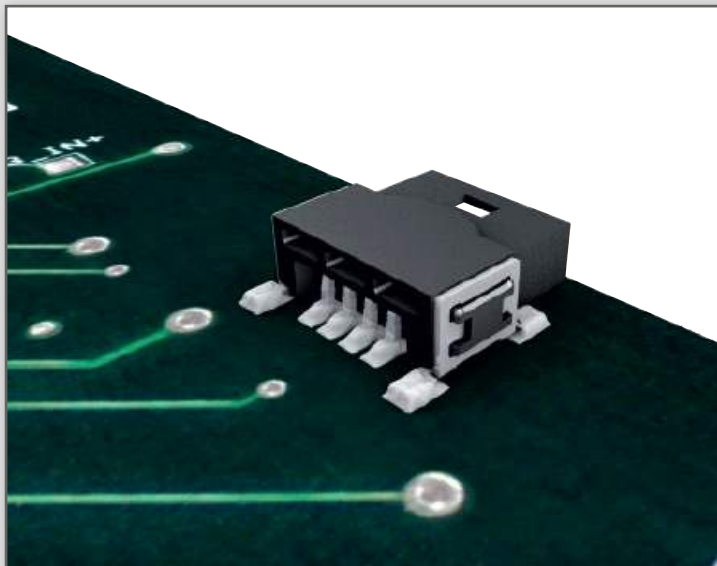

FULLY AUTOMATIC PROCESSING

The use of reflow and SMD-solderable components in automated mount and soldering processes simplifies, and hence optimizes, the production of PCBs.





PCB connectors with IDC termination
for SMT reflow soldering
pitch 1.27 mm

Identification	No. of contacts	Part number	Packaging unit (pieces)
PCB connectors with IDC termination			
Female	4	14 31 041 0301 000	50
Male	4	14 11 041 0002 ...	560
Screw driver, 1.5 x 40		14 99 000 0002	

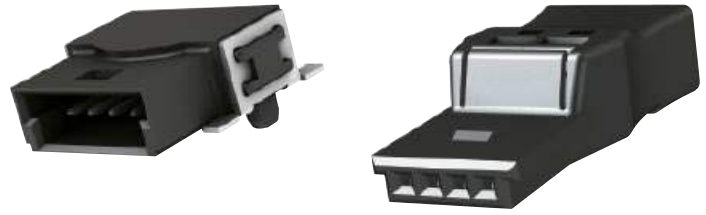

PCB connectors with IDC termination
for SMT reflow soldering
pitch 1.27 mm

Drawing

Dimensions in mm

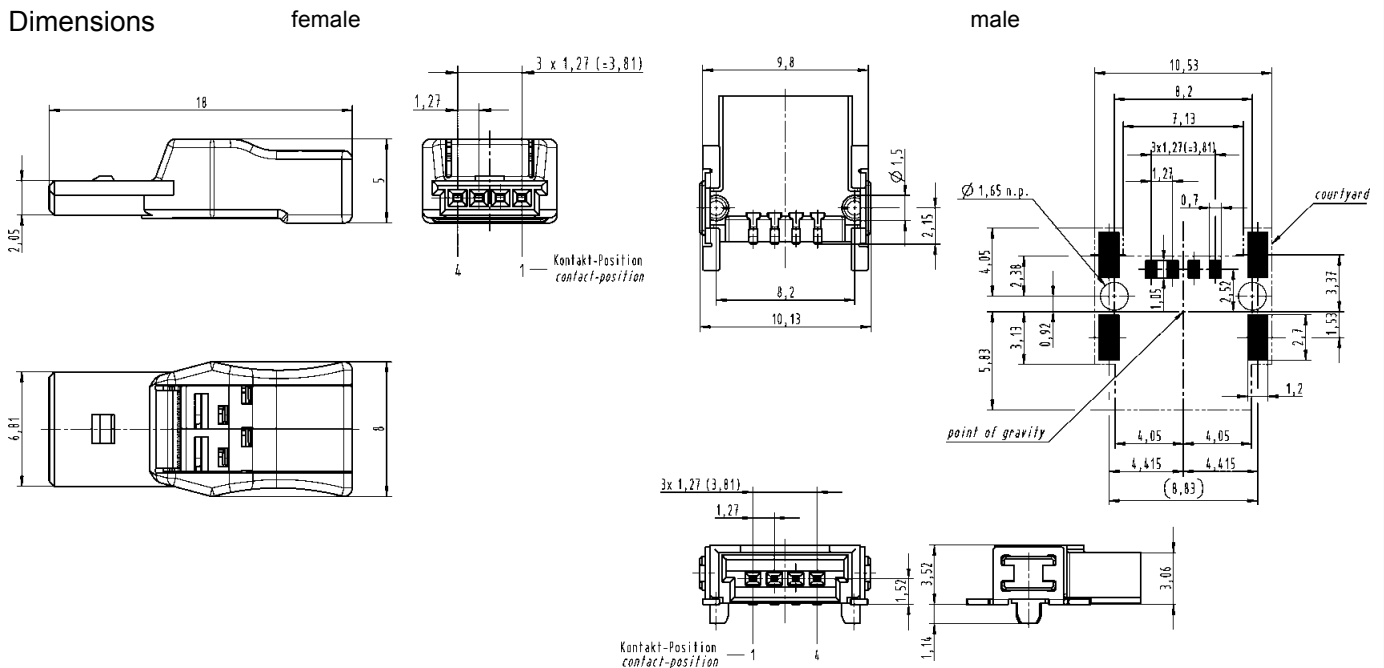

Technical characteristics

Technical data

Rated current 2 A
Pitch 1.27 mm

Surge voltage category / pollution degree	III/3	III/2	II/2
Rated voltage	-	-	16 V
Rated surge voltage	-	-	0.5 kV

Material data

Group of insulation material III a
Type of insulation material LCP
Flammability rating per UL 94 V0
Operating temperature -40 °C ... +125 °C
Contact material Copper alloy
Contact plating Nickel plated
 UL approval (E 102079)

Conductor data

Connection technology wire IDC termination
Conductor size solid / stranded - / 0.05 - 0.14 mm²
Conductor size AWG 28 - 26
Stripping length 0 mm
Conductor diameter max. 1 mm

Derating

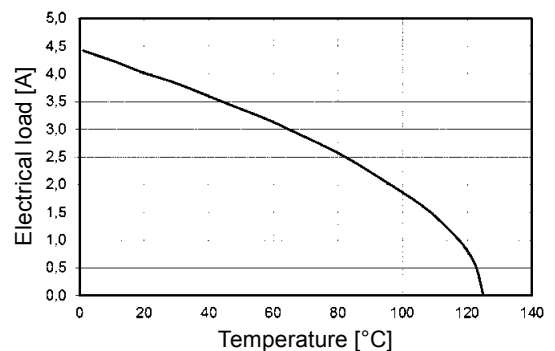

Tested with AWG 26/19

PCB terminal blocks,
vertical/horizontal
with push-in-spring-cage termination
for SMT reflow soldering
pitch 2.54 mm



Identification	No. of contacts	Part number	Packaging unit (pieces)
PCB terminal blocks, vertical/horizontal with push-in-spring-cage termination			vertical / horizontal
	2	14 01 021 310 . . .	250 / 500
	3	14 01 031 310 . . .	250 / 500
	4	14 01 041 310 . . .	250 / 500
	5	14 01 051 310 . . .	250 / 500
	6	14 01 061 310 . . .	250 / 500
	7	14 01 071 310 . . .	250 / 500
	8	14 01 081 310 . . .	250 / 500
	9	14 01 091 310 . . .	250 / 500
	10	14 01 101 310 . . .	250 / 500
	11	14 01 111 310 . . .	250 / 500
	12	14 01 121 310 . . .	250 / 500

Please insert digit for

- vertical ► 1
- horizontal ► 2

PCB terminal blocks,
vertical/horizontal
with push-in-spring-cage termination
for SMT reflow soldering
pitch 2.54 mm



Drawing

Dimensions in mm

Dimensions

vertical

horizontal

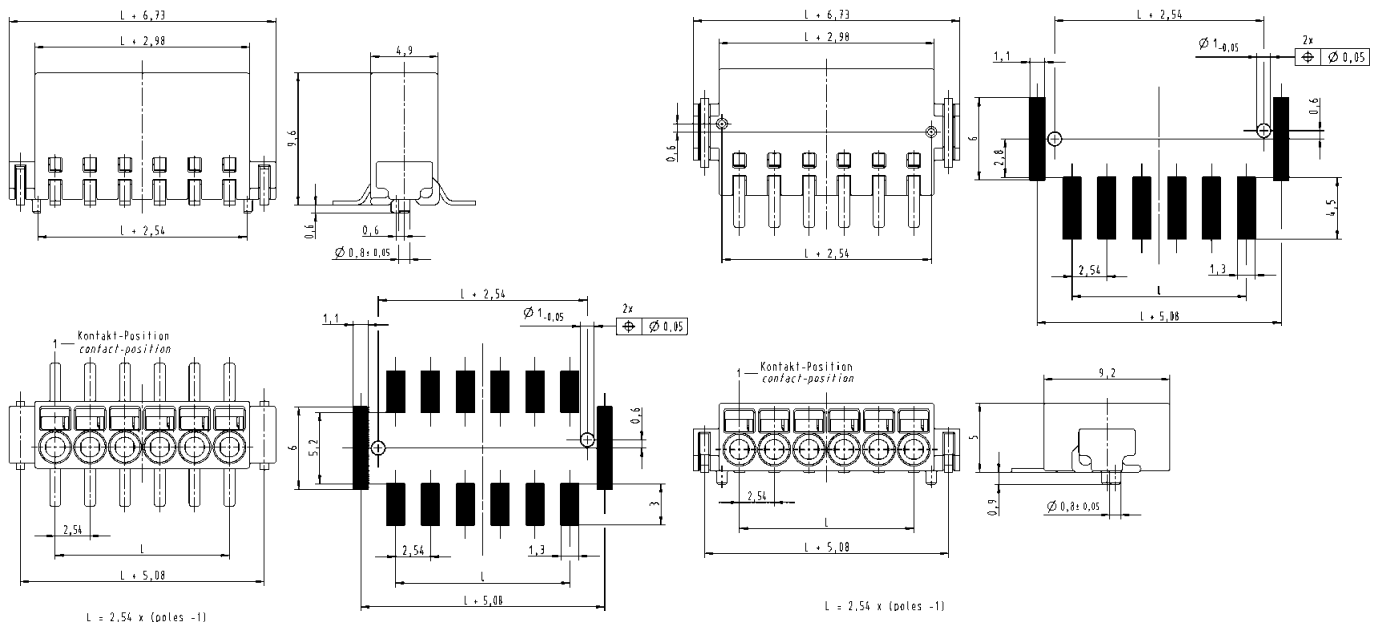

Technical characteristics

Technical data

Rated current 6 A
Pitch 2.54 mm

Surge voltage category /
pollution degree

III/3	III/2	II/2
32 V	160 V	160 V
2.5 kV	2.5 kV	2.5 kV

Rated voltage

Rated surge voltage

Material data

Group of insulation material III a
Type of insulation material LCP
Flammability rating per UL 94 V0
Operating temperature -40 °C ... +125 °C
Contact material copper alloy
Contact plating tin plated
 UL approval (E 102079)

Conductor data

Connection technology wire push-in-spring-cage termination
Conductor size solid / stranded 0.14 - 0.5 / 0.2 - 0.5 mm²
stranded with ferrules 0.25 - 0.34 mm²
without plastic sleeve
Conductor size AWG 24 - 20
Stripping length 6 mm

Derating

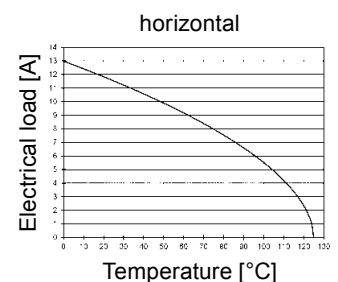
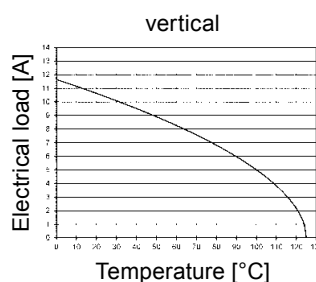

Tested with AWG 20

Tested with AWG 20

PCB connectors female,
vertical
with push-in-spring-cage termination
pitch 2.54 mm



Identification	No. of contacts	Part number	Packaging unit (pieces)
PCB connectors female, vertical with push-in-spring-cage termination			
	2	14 31 021 3101 000	100
	3	14 31 031 3101 000	100
	4	14 31 041 3101 000	100
	5	14 31 051 3101 000	75
	6	14 31 061 3101 000	75
	7	14 31 071 3101 000	75
	8	14 31 081 3101 000	50
	9	14 31 091 3101 000	50
	10	14 31 101 3101 000	50
	11	14 31 111 3101 000	25
	12	14 31 121 3101 000	25

PCB connectors female,
vertical
with push-in-spring-cage termination
pitch 2.54 mm



Drawing

Dimensions in mm

Dimensions

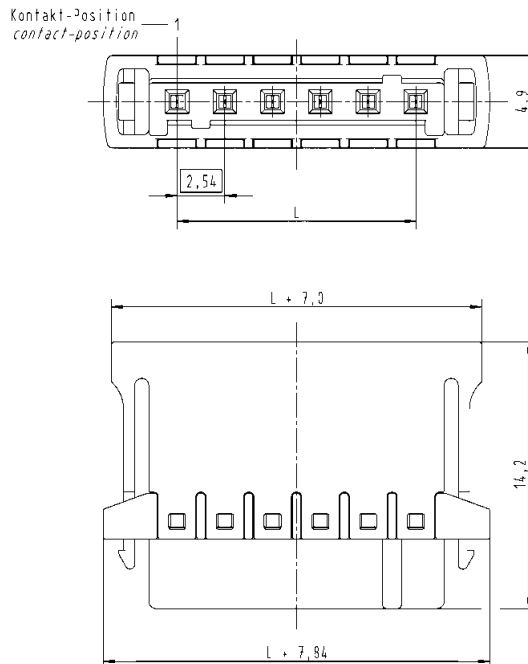

L = pitch x (poles - 1)

Technical characteristics

Technical data

Rated current 6 A
Pitch 2.54 mm

Surge voltage category /
pollution degree

	III/3	III/2	II/2
Rated voltage	32 V	160 V	160 V
Rated surge voltage	2.5 kV	2.5 kV	2.5 kV

Rated voltage

Rated surge voltage

Material data

Group of insulation material III a
Type of insulation material LCP
Flammability rating per UL 94 V0
Operating temperature -40 °C ... +125 °C
Contact material copper alloy
Contact plating tin plated
 UL approval (E 102079)

Conductor data

Connection technology wire push-in-spring-cage termination
Conductor size solid / stranded 0.14 - 0.5 / 0.2 - 0.5 mm²
stranded with ferrules 0.25 - 0.34 mm²
without plastic sleeve
Conductor size AWG 24 - 20
Stripping length 6 mm

Derating

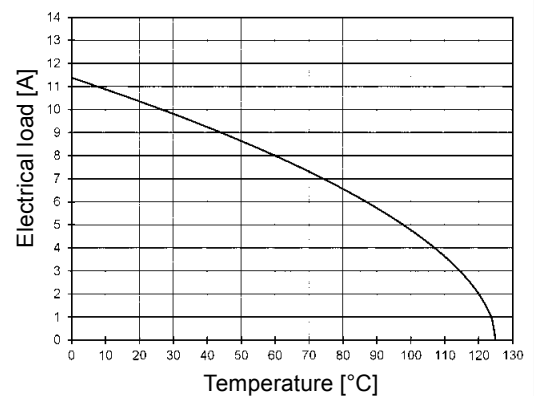

Tested with AWG 20



PCB connectors male,
vertical/horizontal
for SMT reflow soldering
pitch 2.54 mm

Identification	No. of contacts	Part number	Packaging unit (pieces)
PCB connectors male, vertical/horizontal			vertical / horizontal
	2	14 11 021 300	500 / 600
	3	14 11 031 300	500 / 600
	4	14 11 041 300	500 / 600
	5	14 11 051 300	500 / 600
	6	14 11 061 300	500 / 600
	7	14 11 071 300	500 / 600
	8	14 11 081 300	500 / 600
	9	14 11 091 300	500 / 600
	10	14 11 101 300	500 / 600
	11	14 11 111 300	500 / 600
	12	14 11 121 300	500 / 600

Please insert digit for

- vertical ► 1
- horizontal ► 2

PCB connectors male, vertical/horizontal for SMT reflow soldering pitch 2.54 mm



Drawing

Dimensions in mm

Dimensions

vertical

horizontal

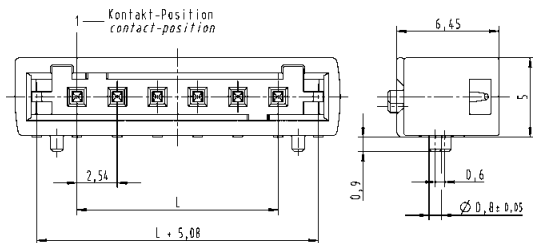
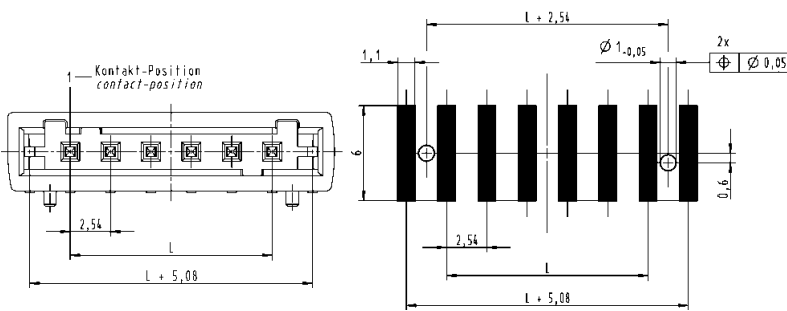
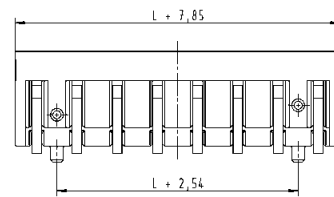
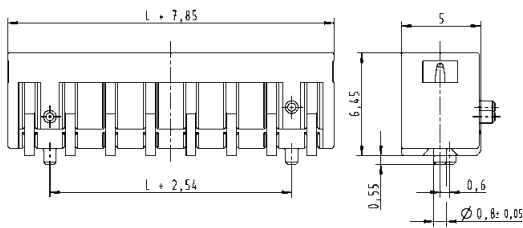

L = pitch x (poles - 1)

Technical characteristics

Technical data

Rated current 6 A
Pitch 2.54 mm

Surge voltage category / pollution degree

III/3	III/2	II/2
32 V	160 V	160 V
2.5 kV	2.5 kV	2.5 kV

Rated voltage

Rated surge voltage

Material data

Group of insulation material III a
Type of insulation material LCP
Flammability rating per UL 94 V0
Operating temperature -40 °C ... +125 °C
Contact material copper alloy
Contact plating tin plated
UL approval (E 102079)



Derating

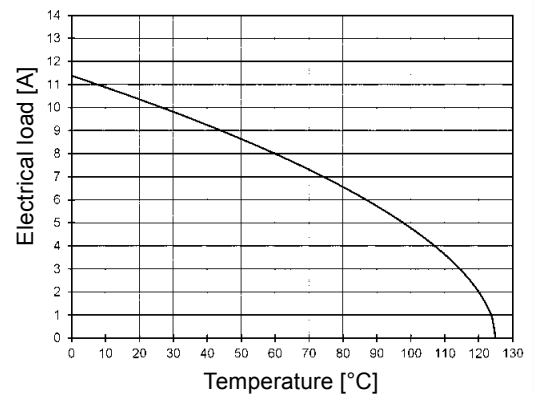

Tested with AWG 20

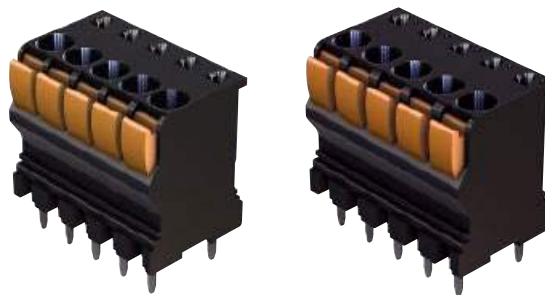

PCB terminal blocks,
vertical with push-in-spring-cage termination
for reflow soldering
pitch 3.50 / 3.81 mm

Identification	No. of contacts	Part number	Packaging unit (pieces)
PCB terminal blocks, vertical with push-in-spring-cage termination	2	14 02 021 . 101 ...	100
	3	14 02 031 . 101 ...	100
	4	14 02 041 . 101 ...	75
	5	14 02 051 . 101 ...	75
	6	14 02 061 . 101 ...	50
	7	14 02 071 . 101 ...	50
	8	14 02 081 . 101 ...	50
	9	14 02 091 . 101 ...	50
	10	14 02 101 . 101 ...	50
	11	14 02 111 . 101 ...	50
	12	14 02 121 . 101 ...	50
	13	14 02 131 . 101 ...	50
	14	14 02 141 . 101 ...	50
	15	14 02 151 . 101 ...	50
	16	14 02 161 . 101 ...	50

Please insert digit for

- pitch 3.50 mm ▶ 4
- pitch 3.81 mm ▶ 5

PCB terminal blocks,
vertical with push-in-spring-cage
termination for reflow soldering
pitch 3.50 / 3.81 mm

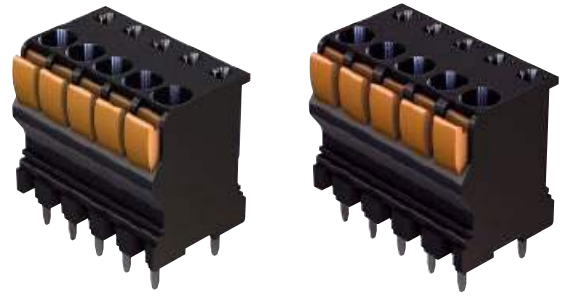

Drawing

Dimensions in mm

Dimensions

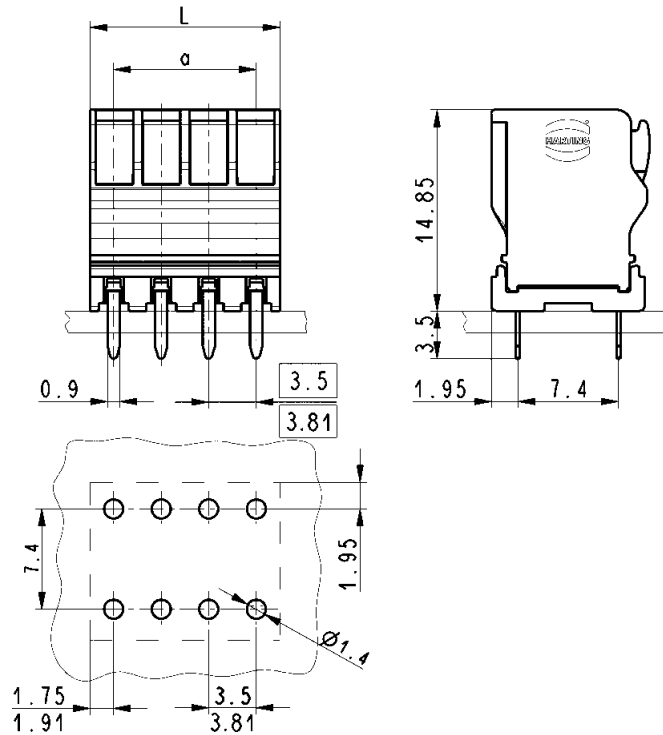

L = pitch x poles
a = pitch x (poles - 1)

Technical characteristics

Technical data

Rated current 10 A
Pitch 3.50 mm / 3.81 mm

Surge voltage category /
pollution degree

III/3	III/2	II/2
220 V	300 V	600 V
4 kV	4 kV	4 kV

Rated voltage

Rated surge voltage

Material data

Group of insulation material I
Type of insulation material PA / PPA
Flammability rating per UL 94 V0
Operating temperature -40 °C ... +110 °C
Contact material copper alloy
Contact plating tin plated
UL approval (E 102079)



Conductor and solder pin data

Connection technology wire push-in-spring-cage
termination
Conductor size solid / stranded 0.14 - 1.5 / 0.14 - 1.5 mm²
stranded with ferrules 0.50 - 1.5 / 0.10 - 1.5 mm²
without / with plastic sleeve
Conductor size AWG 30 - 16
Stripping length 9 - 10 mm
Solder pin: drilled hole diameter 1.4 mm

Approval data (UL)

Use group	B	C	D
Rated voltage	300 V	-	300 V
Rated current	10 A	-	10 A

PCB terminal blocks,
horizontal with screw termination
for reflow soldering
pitch 3.50 / 3.81 mm



Identification	No. of contacts	Part number	Packaging unit (pieces)
PCB terminal blocks, horizontal with screw termination			
	2	14 02 021 . 402 ...	100
	3	14 02 031 . 402 ...	100
	4	14 02 041 . 402 ...	75
	5	14 02 051 . 402 ...	75
	6	14 02 061 . 402 ...	50
	7	14 02 071 . 402 ...	50
	8	14 02 081 . 402 ...	50
	9	14 02 091 . 402 ...	50
	10	14 02 101 . 402 ...	50
	11	14 02 111 . 402 ...	50
	12	14 02 121 . 402 ...	50

Please insert digit for

- pitch 3.50 mm ▶ 4
- pitch 3.81 mm ▶ 5

PCB terminal blocks,
horizontal with screw termination
for reflow soldering
pitch 3.50 / 3.81 mm



Drawing

Dimensions in mm

Dimensions

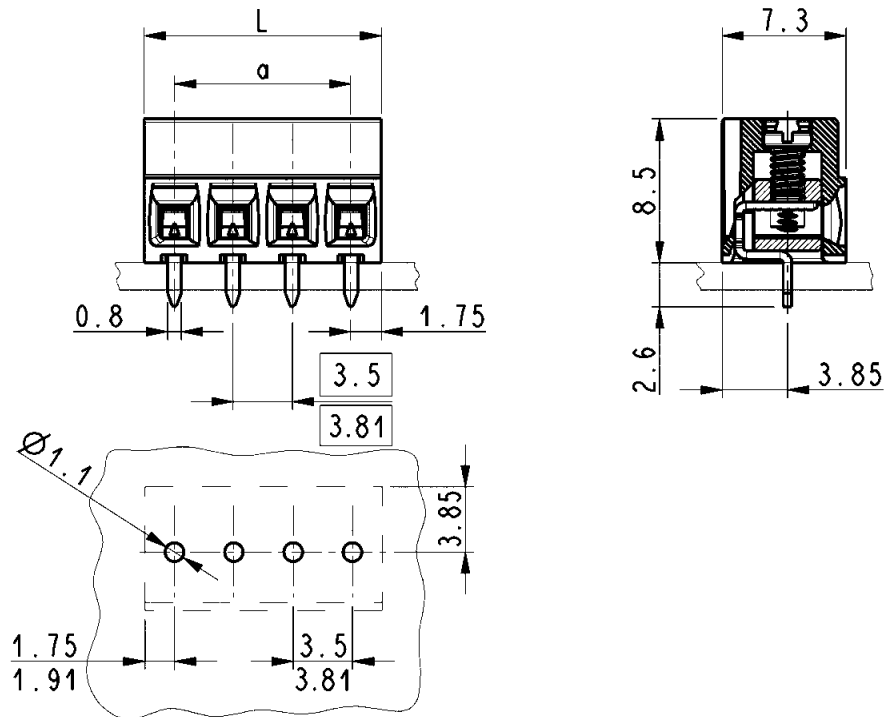

L = pitch x poles
a = pitch x (poles - 1)

Technical characteristics

Technical data

Rated current 12 A
Pitch 3.50 mm / 3.81 mm

Surge voltage category /
pollution degree

III/3	III/2	II/2
150 V	150 V	300 V
2.5 kV	2.5 kV	2.5 kV

Rated voltage

Rated surge voltage

Material data

Group of insulation material I
Type of insulation material PA / PPA
Flammability rating per UL 94 V0
Operating temperature -40 °C ... +110 °C
Contact material copper alloy
Contact plating tin plated
UL approval (E 102079)



Conductor and solder pin data

Connection technology wire screw termination
Conductor size solid / stranded 0.05 - 1.5 / 0.05 - 1 mm²
stranded with ferrules without / with plastic sleeve 0.50 - 1 / 0.10 - 1 mm²
Conductor size AWG 28 - 16
Screw thread M2
Tightening torque 0.2 - 0,25 Nm
Stripping length 5 - 6 mm
Solder pin: drilled hole diameter 1.1 mm

Approval data (UL)

Use group	B	C	D
Rated voltage	300 V	–	300 V
Rated current	12 A	–	12 A

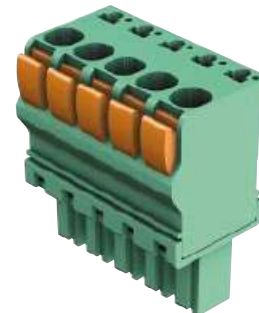
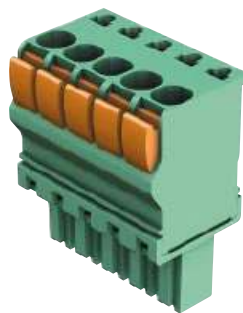

PCB connectors female,
horizontal
with push-in-spring-cage termination
pitch 3.50 / 3.81 mm

Identification	No. of contacts	Part number	Packaging unit (pieces)
PCB connectors female, horizontal with push-in-spring-cage termination	2	14 31 021 . 102 000	300
	3	14 31 031 . 102 000	200
	4	14 31 041 . 102 000	150
	5	14 31 051 . 102 000	150
	6	14 31 061 . 102 000	100
	7	14 31 071 . 102 000	100
	8	14 31 081 . 102 000	100
	9	14 31 091 . 102 000	100
	10	14 31 101 . 102 000	100
	11	14 31 111 . 102 000	100
	12	14 31 121 . 102 000	100
	13	14 31 131 . 102 000	50
	14	14 31 141 . 102 000	50
	15	14 31 151 . 102 000	50
	16	14 31 161 . 102 000	50
	17	14 31 171 . 102 000	50
	18	14 31 181 . 102 000	50
	19	14 31 191 . 102 000	50
	20	14 31 201 . 102 000	50
	21*	14 31 211 . 102 000	25
	22*	14 31 221 . 102 000	25
	23*	14 31 231 . 102 000	25
	24*	14 31 241 . 102 000	25
	25*	14 31 251 . 102 000	25
	Please insert digit for		
	pitch 3.50 mm ▶ 4		
	pitch 3.81 mm ▶ 5		
15	Coding keys	14 95 000 0050 000	120
16			

* Pitch 3.50 mm only available with 2-20 contacts

PCB connectors female,
horizontal
with push-in-spring-cage termination
pitch 3.50 / 3.81 mm

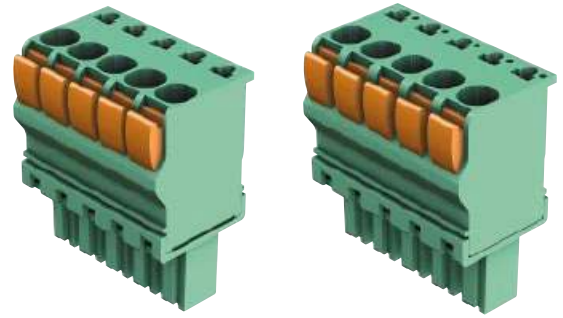

Drawing

Dimensions in mm

Dimensions

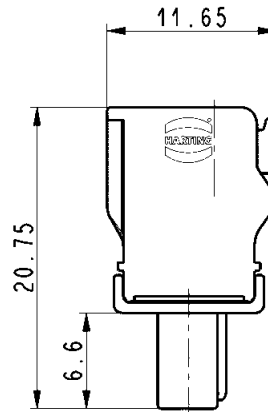
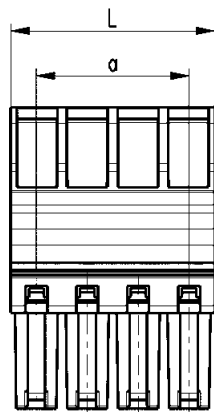
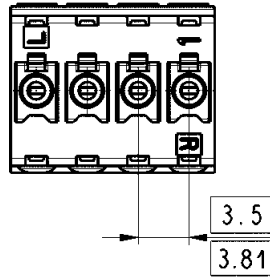

L = pitch x poles
a = pitch x (poles - 1)

Technical characteristics

Technical data

Rated current 11 A
Pitch 3.50 mm / 3.81 mm

Surge voltage category /
pollution degree

III/3	III/2	II/2
150 V	150 V	300 V
2.5 kV	2.5 kV	2.5 kV

Rated voltage

Rated surge voltage

Material data

Group of insulation material I
Type of insulation material PA / PPA
Flammability rating per UL 94 V0
Operating temperature -40 °C ... +110 °C
Contact material copper alloy
Contact plating tin plated
UL approval (E 102079)



Conductor data

Connection technology wire push-in-spring-cage termination
Conductor size solid / stranded 0.14 - 1.5 / 0.14 - 1.5 mm²
stranded with ferrules without / with plastic sleeve 0.50 - 1.5 / 0.10 - 1.5 mm²
Conductor size AWG 30 - 14
Stripping length 9 - 10 mm

Approval data (UL)

Use group		B	C	D
Rated voltage		300 V	-	-
Rated current	solid	9 A	-	-
	stranded	11 A	-	-

PCB connectors female with screw flange,
horizontal
with push-in-spring-cage termination
pitch 3.50 / 3.81 mm

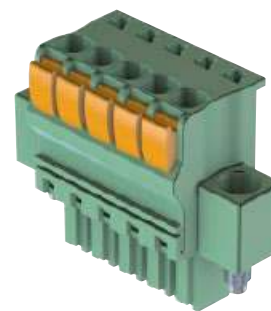

Identification	No. of contacts	Part number	Packaging unit (pieces)
PCB connectors female with screw flange, horizontal with push-in-spring-cage termination	2	14 31 021 . 106 000	300
	3	14 31 031 . 106 000	200
	4	14 31 041 . 106 000	150
	5	14 31 051 . 106 000	150
	6	14 31 061 . 106 000	100
	7	14 31 071 . 106 000	100
	8	14 31 081 . 106 000	100
	9	14 31 091 . 106 000	100
	10	14 31 101 . 106 000	100
	11	14 31 111 . 106 000	100
	12	14 31 121 . 106 000	100
	13	14 31 131 . 106 000	50
	14	14 31 141 . 106 000	50
	15	14 31 151 . 106 000	50
	16	14 31 161 . 106 000	50
	17	14 31 171 . 106 000	50
	18	14 31 181 . 106 000	50
	19	14 31 191 . 106 000	50
	20	14 31 201 . 106 000	50
	21	14 31 211 . 106 000	50
	22	14 31 221 . 106 000	50
	Please insert digit for pitch 3.50 mm ► 4 pitch 3.81 mm ► 5		
15 18 Coding keys	14 95 000 0050 000	120	

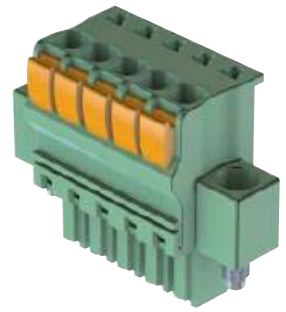

PCB connectors female with screw flange,
horizontal
with push-in-spring-cage termination
pitch 3.50 / 3.81 mm

Drawing

Dimensions in mm

Dimensions

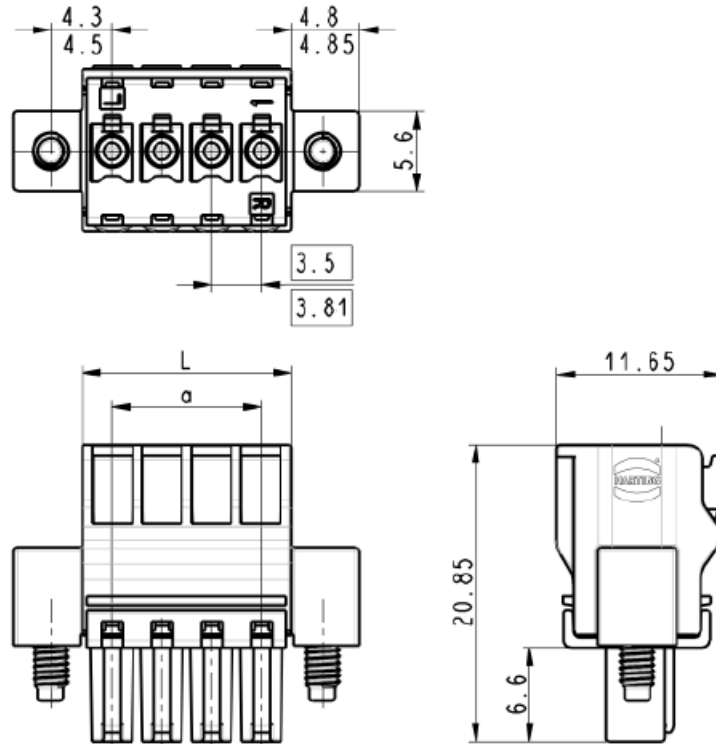

L = (pitch x poles) + 0.7 mm
a = pitch x (poles - 1)

Technical characteristics

Technical data

Rated current 11 A
Pitch 3.50 mm / 3.81 mm

Surge voltage category /
pollution degree

III/3	III/2	II/2
150 V	150 V	300 V
2.5 kV	2.5 kV	2.5 kV

Rated voltage

Rated surge voltage

Material data

Group of insulation material I
Type of insulation material PA / PPA
Flammability rating per UL 94 V0
Operating temperature -40 °C ... +110 °C
Contact material copper alloy
Contact plating tin plated
 UL approval (E 102079)
Screw flange M2.5

Conductor data

Connection technology wire push-in-spring-cage
termination
Conductor size solid / stranded 0.14 - 1.5 / 0.14 - 1.5 mm²
stranded with ferrules
without / with plastic sleeve 0.50 - 1.5 / 0.10 - 1.5 mm²
Conductor size AWG 30 - 14
Stripping length 9 - 10 mm

Approval data (UL)

Use group	B	C	D
Rated voltage	300 V	-	-
Rated current	solid	9 A	-
	stranded	11 A	-

PCB connectors female,
vertical/horizontal
with screw termination
pitch 3.50 / 3.81 mm

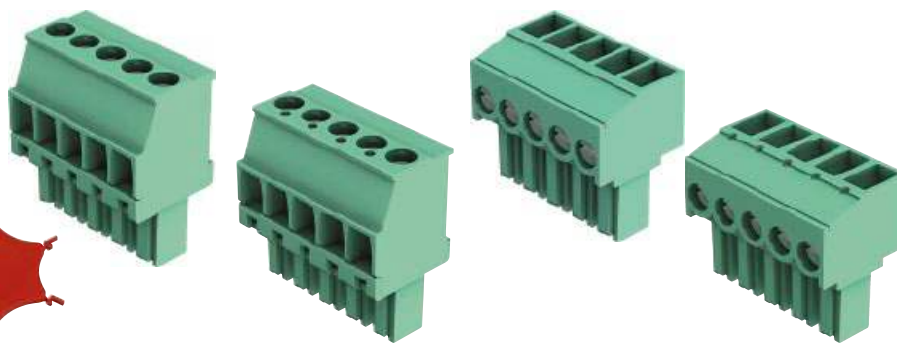

Identification	No. of contacts	Part number	Packaging unit (pieces)
PCB connectors female, vertical/horizontal with screw termination	2	14 31 021 . 40 . 000	300
	3	14 31 031 . 40 . 000	200
	4	14 31 041 . 40 . 000	150
	5	14 31 051 . 40 . 000	150
	6	14 31 061 . 40 . 000	100
	7	14 31 071 . 40 . 000	100
	8	14 31 081 . 40 . 000	100
	9	14 31 091 . 40 . 000	100
	10	14 31 101 . 40 . 000	100
	11	14 31 111 . 40 . 000	100
	12	14 31 121 . 40 . 000	100
	13	14 31 131 . 40 . 000	50
	14	14 31 141 . 40 . 000	50
	15	14 31 151 . 40 . 000	50
	16	14 31 161 . 40 . 000	50
	17*	14 31 171 . 40 . 000	50
	18*	14 31 181 . 40 . 000	50
	19*	14 31 191 . 40 . 000	50
	20*	14 31 201 . 40 . 000	50
	21*	14 31 211 . 40 . 000	25
	22*	14 31 221 . 40 . 000	25
	23*	14 31 231 . 40 . 000	25
	24*	14 31 241 . 40 . 000	25
	25*	14 31 251 . 40 . 000	25
	Please insert digit for		
pitch 3.50 mm ▶	4		
pitch 3.81 mm ▶	5		
vertical ▶	1		
horizontal ▶	2		
Coding keys		14 95 000 0050 000	120

har-flexicon

* Pitch 3.81 mm (vertical) only available with 2-16 contacts

PCB connectors female, vertical/horizontal with screw termination pitch 3.50 / 3.81 mm

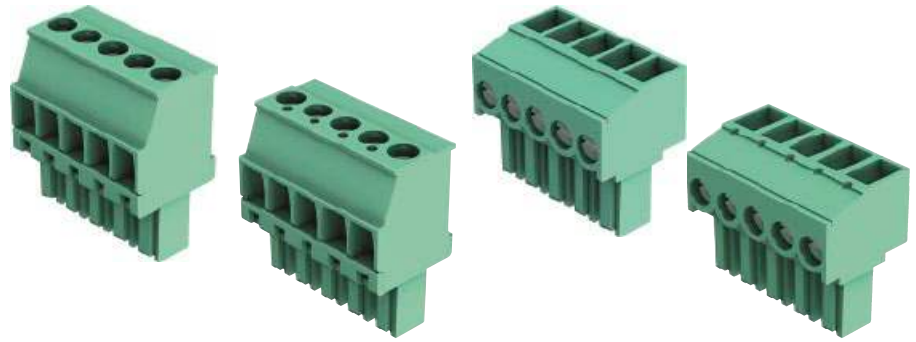

Drawing

Dimensions in mm

Dimensions

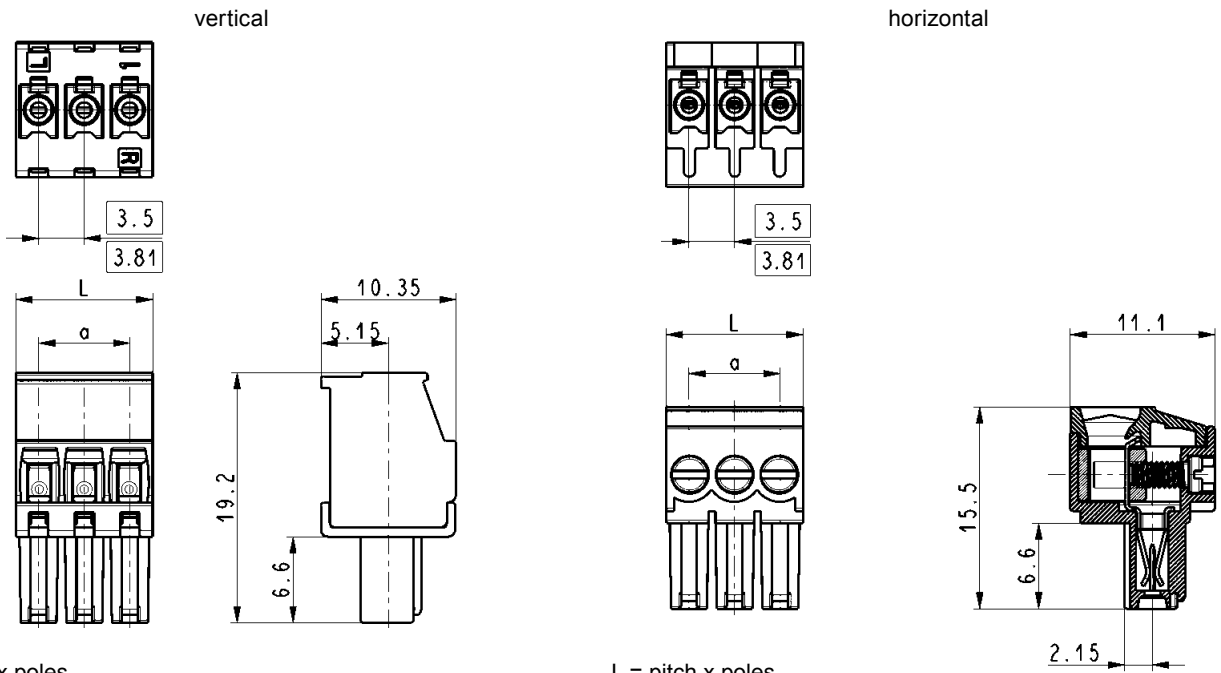

L = pitch x poles
a = pitch x (poles - 1)

L = pitch x poles
a = pitch x (poles - 1)

Technical characteristics

Technical data

Rated current 10 A
Pitch 3.50 mm / 3.81 mm

Surge voltage category / pollution degree	III/3	III/2	II/2
Rated voltage	150 V	150 V	300 V
Rated surge voltage	2.5 kV	2.5 kV	2.5 kV

Conductor data

Connection technology wire screw termination
Conductor size solid / stranded 0.05 - 1.5 / 0.05 - 1 mm²
stranded with ferrules
without / with plastic sleeve 0.50 - 1 / 0.10 - 1 mm²
Conductor size AWG 30 - 14
Screw thread M2
Tightening torque 0.2 - 0.25 Nm
Stripping length 5.0 - 6.0 mm

Material data

Group of insulation material I
Type of insulation material PA / PPA
Flammability rating per UL 94 V0
Operating temperature -40 °C ... +110 °C
Contact material copper alloy
Contact plating tin plated
UL approval (E 102079)

Approval data (UL)

Use group		B	C	D
Rated voltage		300 V	–	300 V
Rated current	vertical	10 A	–	10 A
	horizontal	11 A	–	11 A

PCB connectors male,
vertical
for wave soldering
pitch 3.50 mm



Identification	No. of contacts	Part number	Packaging unit (pieces)
Connectors, male, vertical			
	2	14 13 021 4001 000	100
	3	14 13 031 4001 000	100
	4	14 13 041 4001 000	75
	5	14 13 051 4001 000	75
	6	14 13 061 4001 000	50
	7	14 13 071 4001 000	50
	8	14 13 081 4001 000	50
	9	14 13 091 4001 000	50
	10	14 13 101 4001 000	50
	11	14 13 111 4001 000	50
	12	14 13 121 4001 000	50
Coding keys		14 95 000 0052 000	120



PCB connectors male,
vertical
for wave soldering
pitch 3.50 mm

Drawing

Dimensions in mm

Dimensions

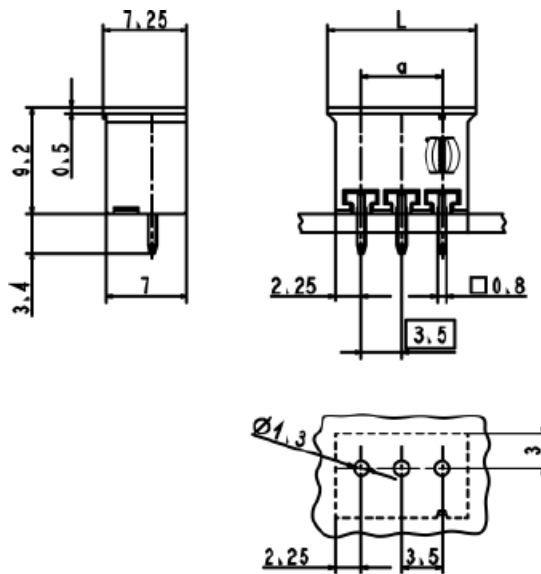

$L = (\text{pitch} \times \text{poles}) + 2.3 \text{ mm}$
 $a = \text{pitch} \times (\text{poles} - 1)$

Technical characteristics

Technical data

Rated current 11 A
 Pitch 3.50 mm

Surge voltage category /
 pollution degree

	III/3	III/2	II/2
Rated voltage	150 V	150 V	300 V
Rated surge voltage	2.5 kV	2.5 kV	2.5 kV

Material data

Group of insulation material I
 Type of insulation material PA
 Flammability rating per UL 94 V0
 Operating temperature -40 °C ... +110 °C
 Contact material copper alloy
 Contact plating tin plated
 UL approval (E 102079)



Solder pin data

Solder pin: drilled hole diameter 1.3 mm

Approval data (UL)

Use group	B	C	D
Rated voltage	300 V	–	300 V
Rated current	11 A	–	11 A

PCB connectors male,
vertical/horizontal
for reflow soldering
pitch 3.50 / 3.81 mm

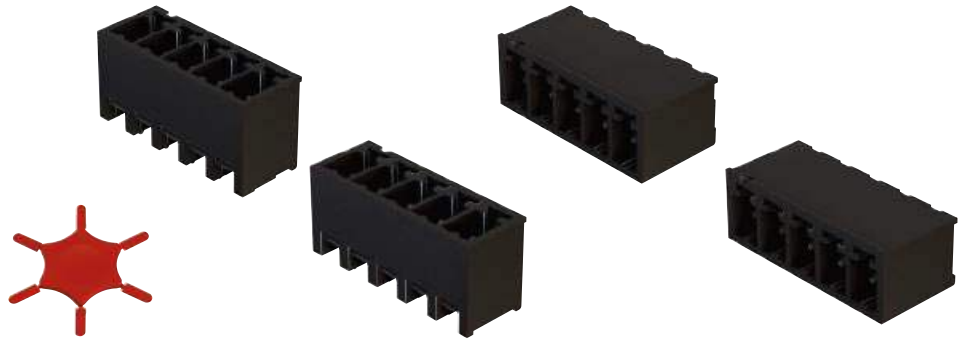

Identification	No. of contacts	Part number	Packaging unit (pieces)
----------------	-----------------	-------------	-------------------------

Connectors,
male, vertical/horizontal

2	14 12 021 . 00	100
3	14 12 031 . 00	100
4	14 12 041 . 00	75
5	14 12 051 . 00	75
6	14 12 061 . 00	50
7	14 12 071 . 00	50
8	14 12 081 . 00	50
9	14 12 091 . 00	50
10	14 12 101 . 00	50
11	14 12 111 . 00	50
12	14 12 121 . 00	50
13	14 12 131 . 00	50
14	14 12 141 . 00	50
15	14 12 151 . 00	50
16	14 12 161 . 00	50
17	14 12 171 . 00	50
18	14 12 181 . 00	50
19	14 12 191 . 00	50
20	14 12 201 . 00	50
21	14 12 211 . 00	25
22	14 12 221 . 00	25
23	14 12 231 . 00	25
24	14 12 241 . 00	25
25	14 12 251 . 00	25

Please insert digit for

- pitch 3.50 mm ▶ 4
- pitch 3.81 mm ▶ 5
- vertical ▶ 1
- horizontal ▶ 2

Coding keys

14 95 000 0052 000

120

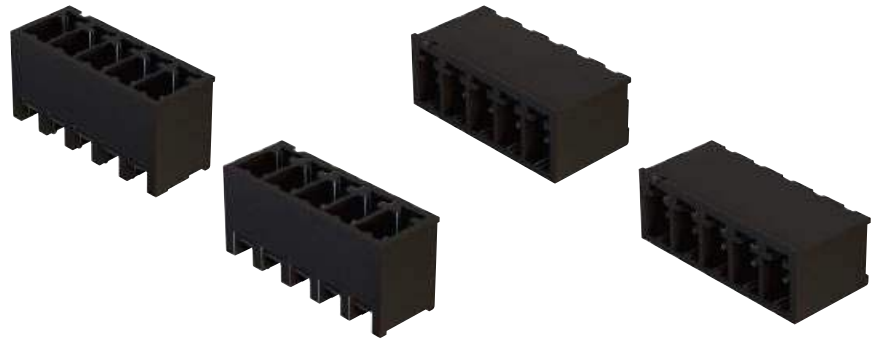

PCB connectors male,
vertical/horizontal
for reflow soldering
pitch 3.50 / 3.81 mm

Drawing

Dimensions in mm

Dimensions

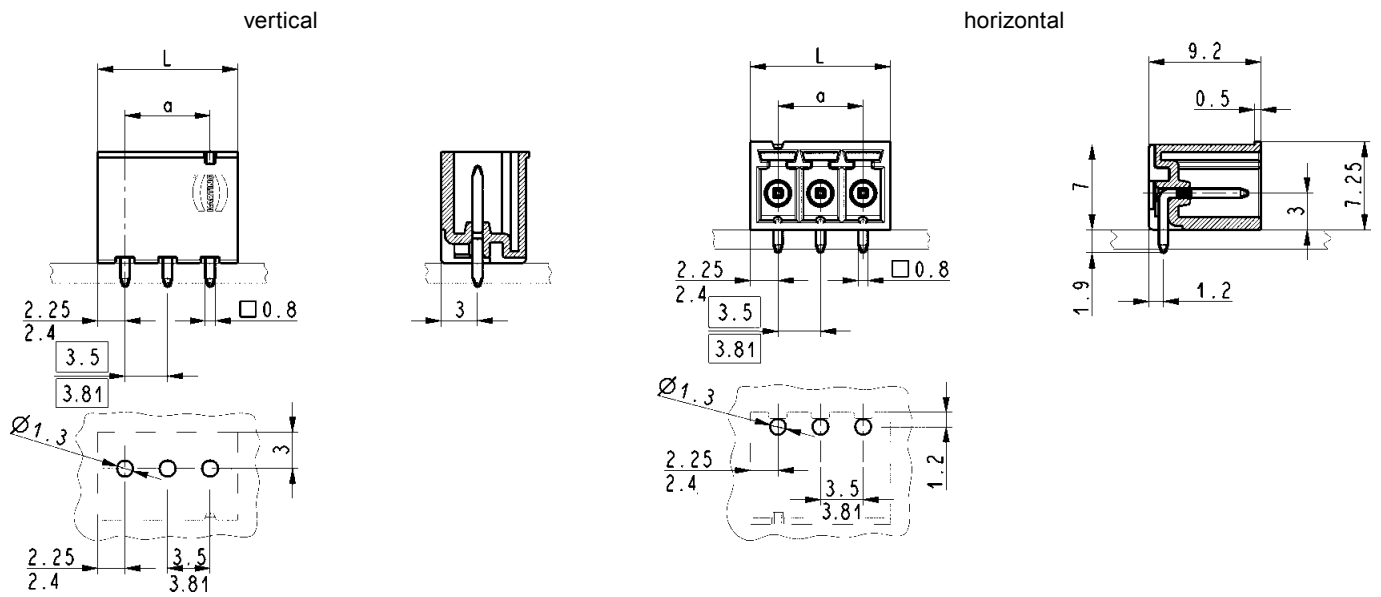

L = (pitch x poles) + 1 mm
a = pitch x (poles - 1)

L = (pitch x poles) + 1 mm
a = pitch x (poles - 1)

Technical characteristics

Technical data

Rated current 11 A
Pitch 3.50 mm / 3.81 mm

Surge voltage category / pollution degree	III/3	III/2	II/2
Rated voltage	150 V	150 V	300 V
Rated surge voltage	2.5 kV	2.5 kV	2.5 kV

Material data

Group of insulation material I
Type of insulation material PA / PPA
Flammability rating per UL 94 V0
Operating temperature -40 °C ... +110 °C
Contact material copper alloy
Contact plating tin plated
UL approval (E 102079)



Solder pin data

Solder pin: drilled hole diameter 1.3 mm

Approval data (UL)

Use group	B	C	D
Rated voltage	300 V	-	300 V
Rated current	11 A	-	11 A

PCB connectors male
with thread flange,
vertical/horizontal
for reflow soldering
pitch 3.50 / 3.81 mm

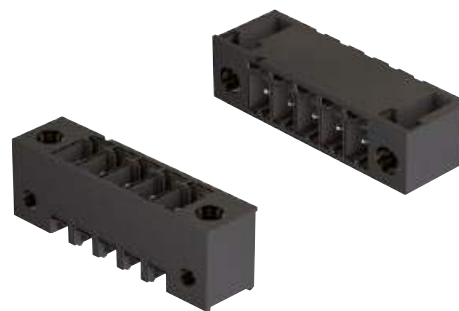

Identification	No. of contacts	Part number	Packaging unit (pieces)
PCB connectors male with thread flange, vertical/horizontal			
	2	14 12 021 . 00	100
	3	14 12 031 . 00	100
	4	14 12 041 . 00	75
	5	14 12 051 . 00	75
	6	14 12 061 . 00	50
	7	14 12 071 . 00	50
	8	14 12 081 . 00	50
	9	14 12 091 . 00	50
	10	14 12 101 . 00	50
	11	14 12 111 . 00	50
	12	14 12 121 . 00	50
	13	14 12 131 . 00	50
	14	14 12 141 . 00	50
	15	14 12 151 . 00	50
	16	14 12 161 . 00	50
	17	14 12 171 . 00	50
	18	14 12 181 . 00	50
	19	14 12 191 . 00	50
	20	14 12 201 . 00	50
	21	14 12 211 . 00	25
	22	14 12 221 . 00	25
Please insert digit for pitch 3.50 mm ▶ 4 pitch 3.81 mm ▶ 5 vertical ▶ 5 horizontal ▶ 6			
Coding keys		14 95 000 0052 000	120

PCB connectors male
with thread flange,
vertical/horizontal
for reflow soldering
pitch 3.50 / 3.81 mm



Drawing

Dimensions in mm

Dimensions

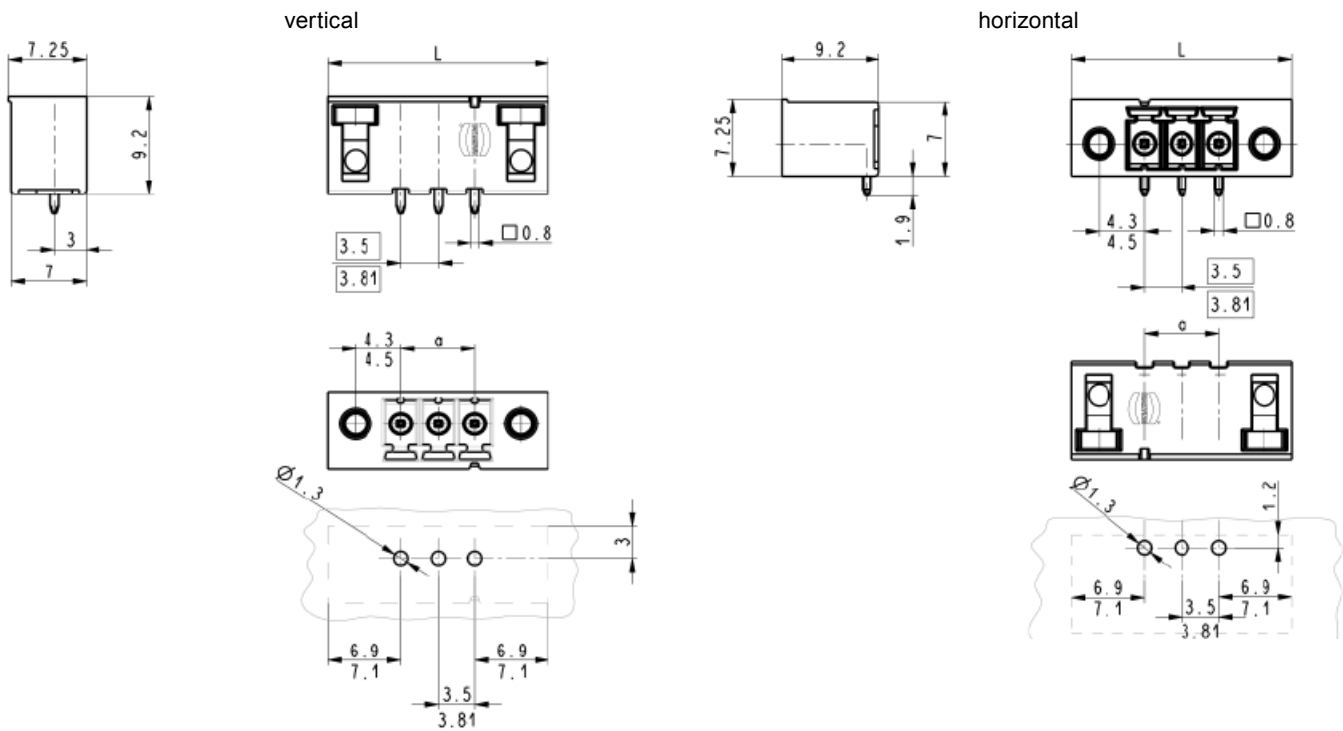

Pitch 3.50 mm: L = (3.50 mm x poles) + 10.3 mm
Pitch 3.81 mm: L = (3.81 mm x poles) + 10.39 mm
a = pitch x (poles - 1)

Pitch 3.50 mm: L = (3.50 mm x poles) + 10.3 mm
Pitch 3.81 mm: L = (3.81 mm x poles) + 10.39 mm
a = pitch x (poles - 1)

Technical characteristics

Technical data

Rated current 11 A
Pitch 3.50 mm / 3.81 mm

Surge voltage category / pollution degree	III/3	III/2	II/2
Rated voltage	150 V	150 V	300 V
Rated surge voltage	2.5 kV	2.5 kV	2.5 kV

Solder pin data

Solder pin: drilled hole diameter 1.3 mm

Material data

Group of insulation material I
Type of insulation material PA / PPA
Flammability rating per UL 94 V0
Operating temperature -40 °C ... +110 °C
Contact material copper alloy
Contact plating tin plated
 UL approval (E 102079)
Thread flange M2.5

Approval data (UL)

Use group	B	C	D
Rated voltage	300 V	-	300 V
Rated current	11 A	-	11 A

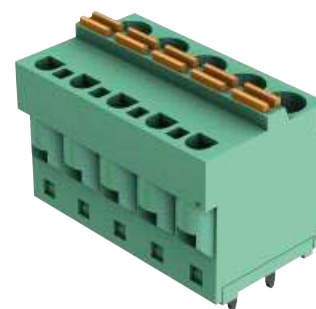

PCB terminal blocks,
vertical with push-in-spring-cage termination
for wave soldering
pitch 5.00 mm

Identification	No. of contacts	Part number	Packaging unit (pieces)
PCB terminal blocks, vertical with push-in-spring-cage termination	2	14 03 021 6101 000	300
	3	14 03 031 6101 000	200
	4	14 03 041 6101 000	150
	5	14 03 051 6101 000	150
	6	14 03 061 6101 000	100
	7	14 03 071 6101 000	100
	8	14 03 081 6101 000	100
	9	14 03 091 6101 000	100
	10	14 03 101 6101 000	100
	11	14 03 111 6101 000	100
	12	14 03 121 6101 000	100
	13	14 03 131 6101 000	50
	14	14 03 141 6101 000	50
	15	14 03 151 6101 000	50
	16	14 03 161 6101 000	50
	17	14 03 171 6101 000	50
	18	14 03 181 6101 000	50

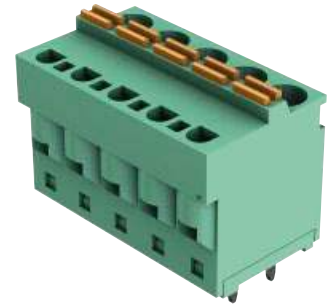

PCB terminal blocks,
vertical with push-in-spring-cage termination
for wave soldering
pitch 5.00 mm

Drawing

Dimensions in mm

Dimensions

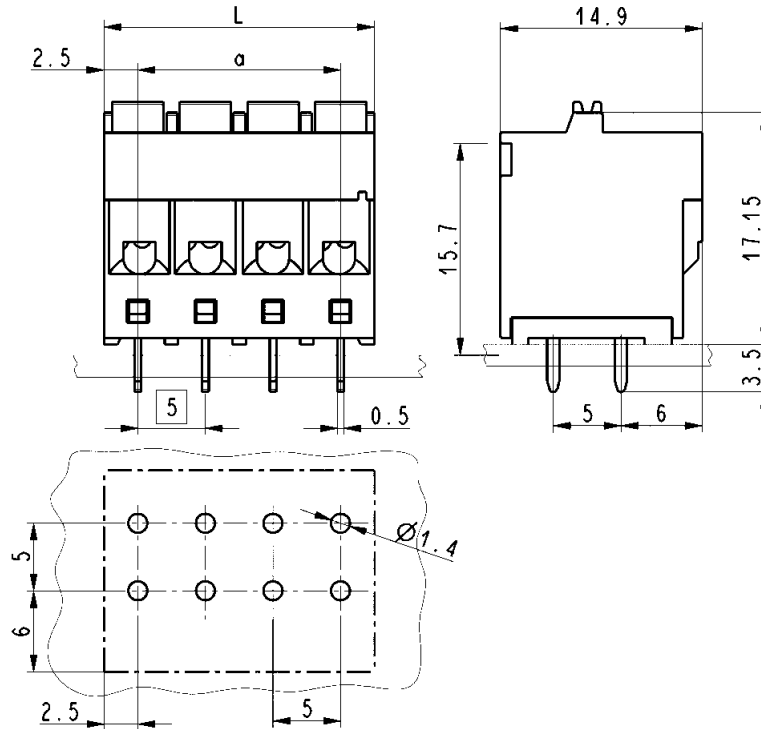

L = pitch x poles
a = pitch x (poles - 1)

Technical characteristics

Technical data

Rated current 12 A
Pitch 5.00 mm

Surge voltage category /
pollution degree

Rated voltage
Rated surge voltage

	III/3	III/2	II/2
Rated voltage	300 V	300 V	600 V
Rated surge voltage	4 kV	4 kV	4 kV

Material data

Group of insulation material I
Type of insulation material PA
Flammability rating per UL 94 V0
Operating temperature -40 °C ... +110 °C
Contact material copper alloy
Contact plating tin plated
UL approval (E 102079)



Conductor and solder pin data

Connection technology wire push-in-spring-cage termination
Conductor size solid / stranded 0.2 - 2.5 / 0.2 - 2.5 mm²
stranded with ferrules 0.5 - 2.5 / 0.5 - 2.5 mm²
without / with plastic sleeve
Conductor size AWG 30 - 12
Stripping length 10 mm
Solder pin: drilled hole diameter 1.4 mm

Approval data (UL)

Use group	B	C	D
Rated voltage	300 V	–	300 V
Rated current	12 A	–	12 A



PCB terminal blocks,
vertical with push-in-spring-cage termination
for reflow soldering
pitch 5.00 mm

Identification	No. of contacts	Part number	Packaging unit (pieces)
PCB terminal blocks, stackable, vertical with push-in-spring-cage termination			
	2	14 02 021 6101 ...	100
	3	14 02 031 6101 ...	100
	4	14 02 041 6101 ...	75



PCB terminal blocks,
vertical with push-in-spring-cage
termination for reflow soldering
pitch 5.00 mm

Drawing

Dimensions in mm

Dimensions

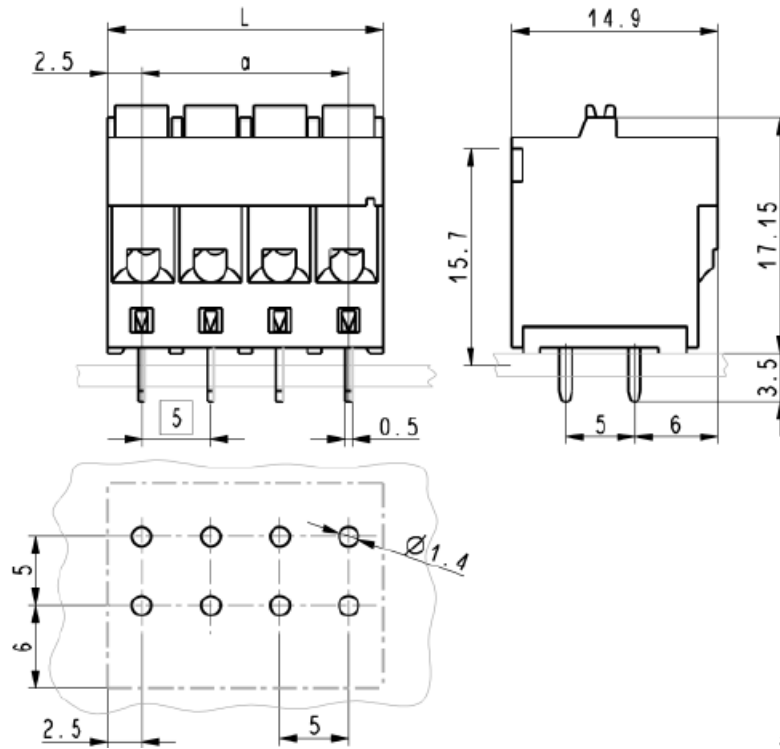

L = pitch x poles
a = pitch x (poles - 1)

Technical characteristics

Technical data

Rated current 12 A
Pitch 5.00 mm

Surge voltage category /
pollution degree

III/3	III/2	II/2
300 V	300 V	600 V
4 kV	4 kV	4 kV

Rated voltage

Rated surge voltage

Material data

Group of insulation material I
Type of insulation material PA / PPA
Flammability rating per UL 94 V0
Operating temperature -40 °C ... +110 °C
Contact material copper alloy
Contact plating tin plated
UL approval (E 102079)



Conductor and solder pin data

Connection technology wire push-in-spring-cage termination
Conductor size solid / stranded 0.2 - 2.5 / 0.2 - 2.5 mm²
stranded with ferrules
without / with plastic sleeve 0.5 - 2.5 / 0.5 - 2.5 mm²
Conductor size AWG 30 - 12
Stripping length 10 mm
Solder pin: drilled hole diameter 1.4 mm

Approval data (UL)

Use group	B	C	D
Rated voltage	300 V	-	300 V
Rated current	12 A	-	12 A



PCB terminal blocks,
horizontal with screw termination
for reflow soldering
pitch 5.00 mm

Identification	No. of contacts	Part number	Packaging unit (pieces)
PCB terminal blocks, horizontal with screw termination for wire gauge 2.5 mm ²			
	2	14 02 021 6404 ...	100
	3	14 02 031 6404 ...	100
	4	14 02 041 6404 ...	75
	5	14 02 051 6404 ...	75
	6	14 02 061 6404 ...	50
	7	14 02 071 6404 ...	50
	8	14 02 081 6404 ...	50



PCB terminal blocks,
horizontal with screw termination
for reflow soldering
pitch 5.00 mm

Drawing

Dimensions in mm

Dimensions

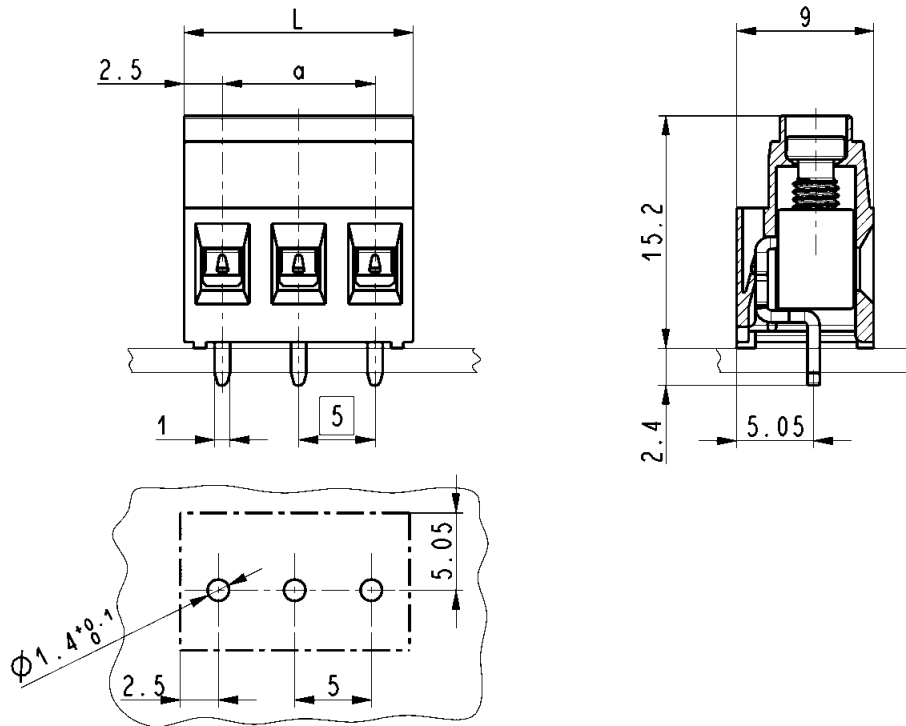

L = pitch x poles
a = pitch x (poles - 1)

Technical characteristics

Technical data

Rated current 17.5 A
Pitch 5.00 mm

Surge voltage category /
pollution degree

III/3	III/2	II/2
300 V	300 V	600 V
4 kV	4 kV	4 kV

Rated voltage

Rated surge voltage

Material data

Group of insulation material I
Type of insulation material PA / PPA
Flammability rating per UL 94 V0
Operating temperature -40 °C ... +110 °C
Contact material copper alloy
Contact plating tin plated
UL approval (E 102079)



Conductor and solder pin data

Connection technology wire screw termination
Conductor size solid / stranded 0.05 - 2.5 / 0.05 - 2.5 mm²
stranded with ferrules without / with plastic sleeve 0.50 - 2.5 / 0.10 - 2.5 mm²
Conductor size AWG 30 - 12
Screw thread M3
Tightening torque 0.5 - 0.6 Nm
Stripping length 5.5 - 6.5 mm
Solder pin: drilled hole diameter 1.4 mm

Approval data (UL)

Use group	B	C	D
Rated voltage	300 V	-	300 V
Rated current	17.5 A	-	17.5 A



PCB terminal blocks,
horizontal with screw termination
for reflow soldering
pitch 5.00 mm

Identification	No. of contacts	Part number	Packaging unit (pieces)
PCB terminal blocks, horizontal with screw termination			
for wire gauge 1.5 mm ²	2	14 02 021 6402 ...	100
	3	14 02 031 6402 ...	100
	4	14 02 041 6402 ...	75
	5	14 02 051 6402 ...	75
	6	14 02 061 6402 ...	50
	7	14 02 071 6402 ...	50
	8	14 02 081 6402 ...	50
	9	14 02 091 6402 ...	50
	10	14 02 101 6402 ...	50
	11	14 02 111 6402 ...	50
	12	14 02 121 6402 ...	50



PCB terminal blocks,
horizontal with screw termination
for reflow soldering
pitch 5.00 mm

Drawing

Dimensions in mm

Dimensions

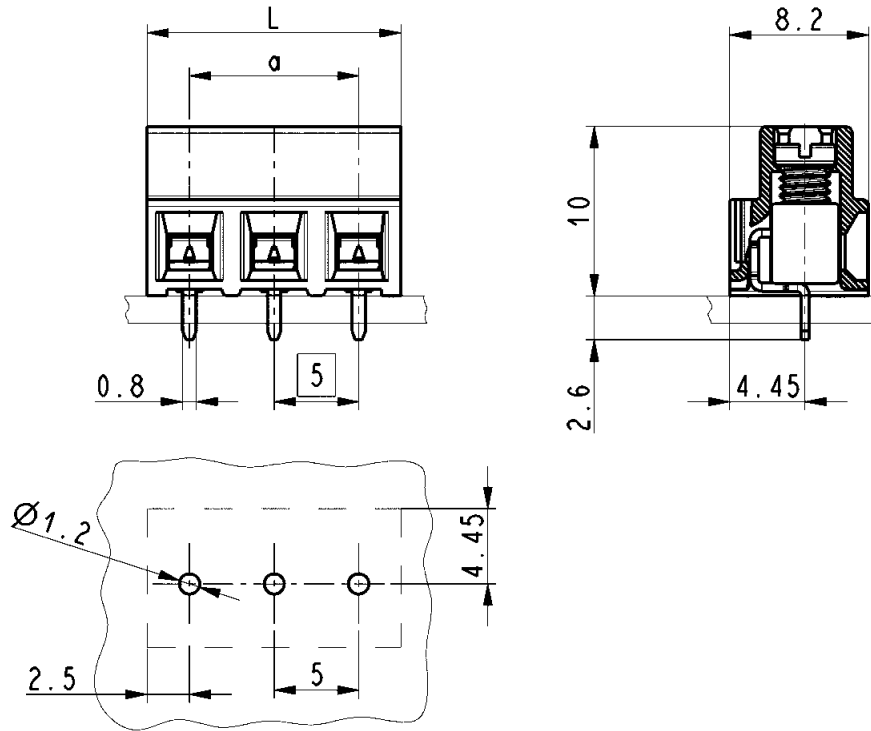

L = pitch x poles
a = pitch x (poles - 1)

Technical characteristics

Technical data

Rated current 13.5 A
Pitch 5.00 mm

Surge voltage category /
pollution degree

III/3	III/2	II/2
220 V	300 V	600 V
4 kV	4 kV	4 kV

Rated voltage

Rated surge voltage

Material data

Group of insulation material I
Type of insulation material PA / PPA
Flammability rating per UL 94 V0
Operating temperature -40 °C ... +110 °C
Contact material copper alloy
Contact plating tin plated
UL approval (E 102079)



Conductor and solder pin data

Connection technology wire screw termination
Conductor size solid / stranded 0.05 - 1.5 / 0.05 - 1.0 mm²
stranded with ferrules without / with plastic sleeve 0.50 - 1.5 / 0.10 - 1.5 mm²
Conductor size AWG 30 - 16
Screw thread M3
Tightening torque 0.5 - 0.6 Nm
Stripping length 5.0 - 6.0 mm
Solder pin: drilled hole diameter 1.2 mm

Approval data (UL)

Use group	B	C	D
Rated voltage	300 V	–	300 V
Rated current	13.5 A	–	13.5 A

PCB connectors female,
horizontal
with push-in-spring-cage termination
pitch 5.00 / 5.08 mm

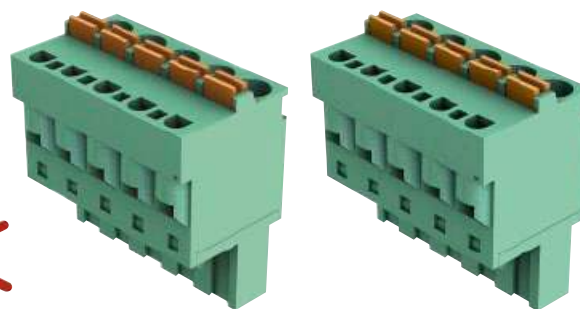

Identification	No. of contacts	Part number	Packaging unit (pieces)
PCB connectors female, horizontal with push-in-spring-cage termination			
	2	14 31 021 . 102 000	300
	3	14 31 031 . 102 000	200
	4	14 31 041 . 102 000	150
	5	14 31 051 . 102 000	150
	6	14 31 061 . 102 000	100
	7	14 31 071 . 102 000	100
	8	14 31 081 . 102 000	100
	9	14 31 091 . 102 000	100
	10	14 31 101 . 102 000	100
	11	14 31 111 . 102 000	100
	12	14 31 121 . 102 000	100
	13	14 31 131 . 102 000	50
	14	14 31 141 . 102 000	50
	15	14 31 151 . 102 000	50
	16	14 31 161 . 102 000	50
	17	14 31 171 . 102 000	50
	18	14 31 181 . 102 000	50
Please insert digit for pitch 5.00 mm ▶ 6 pitch 5.08 mm ▶ 7			
Coding keys		14 95 000 0052 000	120

PCB connectors female,
horizontal
with push-in-spring-cage termination
pitch 5.00 / 5.08 mm

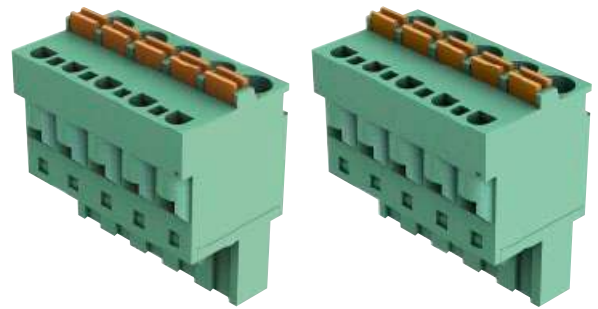

Drawing

Dimensions in mm

Dimensions

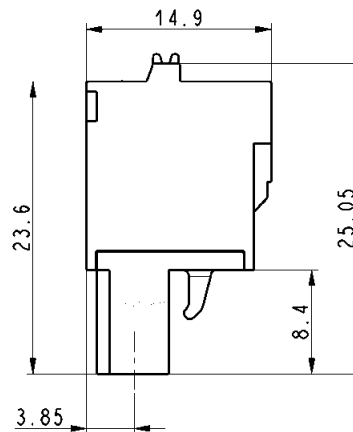
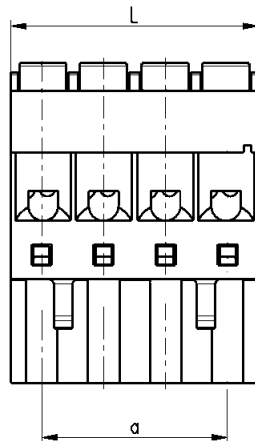
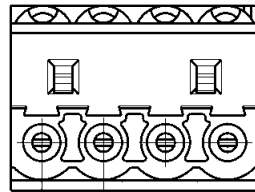

L = pitch x poles
a = pitch x (poles - 1)

Technical characteristics

Technical data

Rated current 12 A
Pitch 5.00 mm / 5.08 mm

Surge voltage category /
pollution degree

III/3	III/2	II/2
250 V	300 V	600 V
4 kV	4 kV	4 kV

Rated voltage

Rated surge voltage

Material data

Group of insulation material I
Type of insulation material PA / PPA
Flammability rating per UL 94 V0
Operating temperature -40 °C ... +110 °C
Contact material copper alloy
Contact plating tin plated
UL approval (E 102079)



Conductor data

Connection technology wire push-in-spring-cage termination
Conductor size solid / stranded 0.2 - 2.5 / 0.2 - 2.5 mm²
stranded with ferrules 0.5 - 2.5 / 0.5 - 2.5 mm²
without / with plastic sleeve
Conductor size AWG 30 - 12
Stripping length 10 mm

Approval data (UL)

Use group	B	C	D
Rated voltage	300 V	–	300 V
Rated current	12 A	–	12 A

PCB connectors female
with screw flange,
horizontal
with push-in-spring-cage termination
pitch 5.08 mm

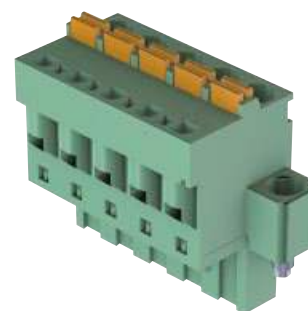

Identification	No. of contacts	Part number	Packaging unit (pieces)
PCB connectors female with screw flange, horizontal with push-in-spring-cage termination	2	14 31 021 7106 000	300
	3	14 31 031 7106 000	200
	4	14 31 041 7106 000	150
	5	14 31 051 7106 000	150
	6	14 31 061 7106 000	100
	7	14 31 071 7106 000	100
	8	14 31 081 7106 000	100
	9	14 31 091 7106 000	100
	10	14 31 101 7106 000	100
	11	14 31 111 7106 000	100
	12	14 31 121 7106 000	100
	13	14 31 131 7106 000	50
	14	14 31 141 7106 000	50
	15	14 31 151 7106 000	50
	16	14 31 161 7106 000	50
	17	14 31 171 7106 000	50
	18	14 31 181 7106 000	50
	Coding keys		14 95 000 0052 000

PCB connectors female
with screw flange,
horizontal
with push-in-spring-cage termination
pitch 5.08 mm

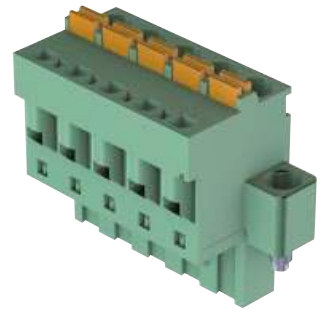

Drawing

Dimensions in mm

Dimensions

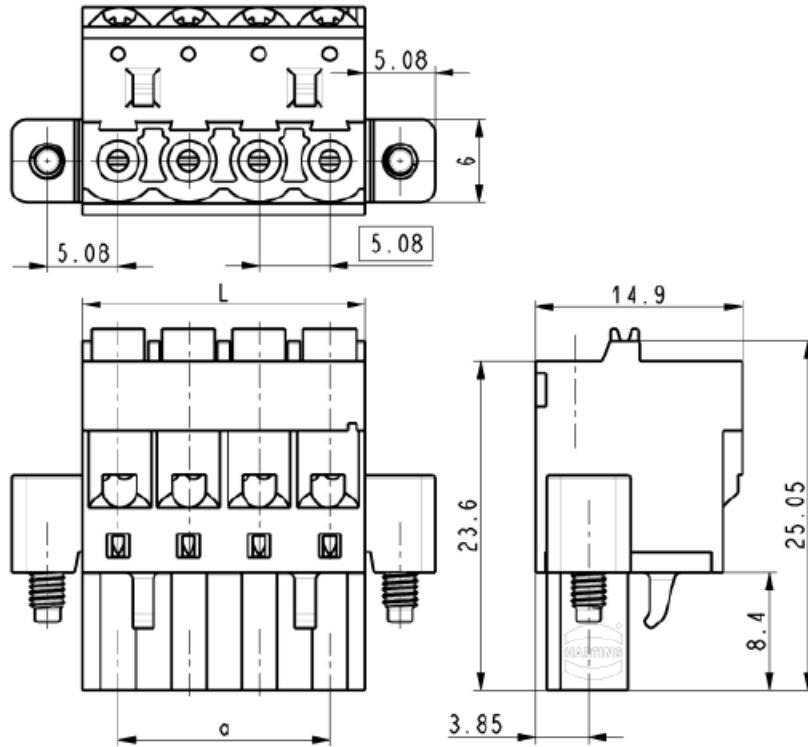

L = pitch x poles
a = pitch x (poles - 1)

Technical characteristics

Technical data

Rated current 12 A
Pitch 5.08 mm

Surge voltage category /
pollution degree

	III/3	III/2	II/2
Rated voltage	250 V	300 V	600 V
Rated surge voltage	4 kV	4 kV	4 kV

Material data

Group of insulation material I
Type of insulation material PA / PPA
Flammability rating per UL 94 V0
Operating temperature -40 °C ... +110 °C
Contact material copper alloy
Contact plating tin plated
 UL approval (E 102079)
Screw flange M2.5

Conductor data

Connection technology wire push-in-spring-cage termination
Conductor size solid / stranded 0.2 - 2.5 / 0.2 - 2.5 mm²
stranded with ferrules
without / with plastic sleeve 0.5 - 2.5 / 0.5 - 2.5 mm²
Conductor size AWG 30 - 12
Stripping length 10 mm

Approval data (UL)

Use group	B	C	D
Rated voltage	300 V	–	300 V
Rated current	12 A	–	12 A

PCB connectors female,
vertical / horizontal
with screw termination
pitch 5.00 / 5.08 mm

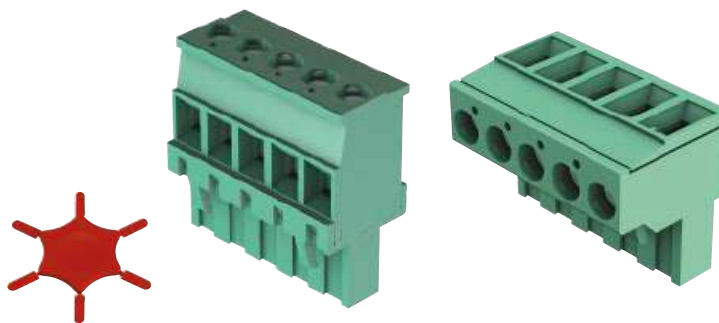

Identification	No. of contacts	Part number	Packaging unit (pieces)
PCB connectors female, vertical / horizontal with screw termination	2	14 31 021 . 40 . 000	300
	3	14 31 031 . 40 . 000	200
	4	14 31 041 . 40 . 000	150
	5	14 31 051 . 40 . 000	150
	6	14 31 061 . 40 . 000	100
	7	14 31 071 . 40 . 000	100
	8	14 31 081 . 40 . 000	100
	9	14 31 091 . 40 . 000	100
	10	14 31 101 . 40 . 000	100
	11	14 31 111 . 40 . 000	100
	12	14 31 121 . 40 . 000	100
	13	14 31 131 . 40 . 000	50
	14	14 31 141 . 40 . 000	50
	15	14 31 151 . 40 . 000	50
	16	14 31 161 . 40 . 000	50
	17	14 31 171 . 40 . 000	50
	18	14 31 181 . 40 . 000	50
	19	14 31 191 . 40 . 000	50
	20	14 31 201 . 40 . 000	50
	21	14 31 211 . 40 . 000	25
	22	14 31 221 . 40 . 000	25
	23	14 31 231 . 40 . 000	25
	24	14 31 241 . 40 . 000	25
	25	14 31 251 . 40 . 000	25
	<p>Please insert digit for</p> <p>pitch 5.00 mm ► 6</p> <p>pitch 5.08 mm ► 7</p> <p>vertical* ► 1</p> <p>horizontal ► 2</p>		
15 40	Coding keys	14 95 000 0052 000	120

* Only available in 5.08 mm pitch

PCB connectors female,
vertical / horizontal
with screw termination
pitch 5.00 / 5.08 mm

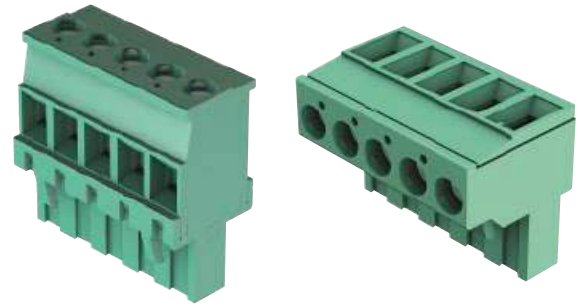

Drawing

Dimensions in mm

Dimensions

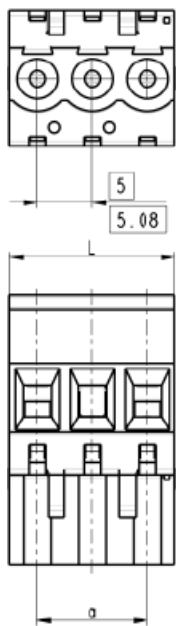

vertical

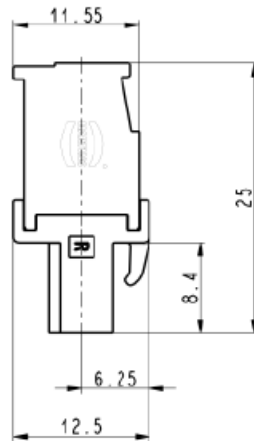

L = pitch x poles
a = pitch x (poles - 1)

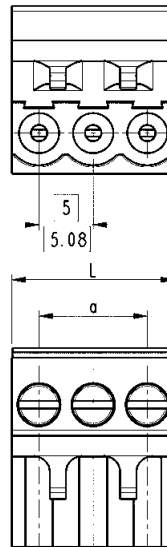

horizontal

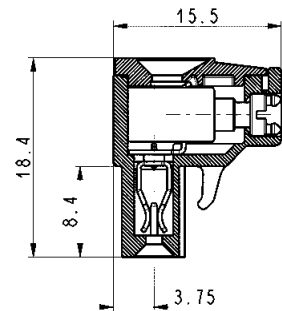

L = pitch x poles
a = pitch x (poles - 1)

Technical characteristics

Technical data

Rated current 15 A
Pitch 5.00 mm / 5.08 mm

Surge voltage category /
pollution degree

III/3	III/2	II/2
250 V	300 V	600 V
4 kV	4 kV	4 kV

Rated voltage

Rated surge voltage

Material data

Group of insulation material I
Type of insulation material PA / PPA
Flammability rating per UL 94 V0
Operating temperature -40 °C ... +110 °C
Contact material copper alloy
Contact plating tin plated
UL approval (E 102079)



Conductor data

Connection technology wire screw termination
Conductor size solid / stranded 0.05 - 2.5 / 0.05 - 2.5 mm²
stranded with ferrules 0.50 - 2.5 / 0.10 - 2.5 mm²
without / with plastic sleeve
Conductor size AWG 30 - 12
Screw thread M3
Tightening torque 0.5 - 0.6 Nm
Stripping length 6.0 - 7.5 mm

Approval data (UL)

Use group	B	C	D
Rated voltage	300 V	–	300 V
Rated current	15 A	–	15 A

PCB connectors male,
vertical
for wave soldering
pitch 5.00 / 5.08 mm

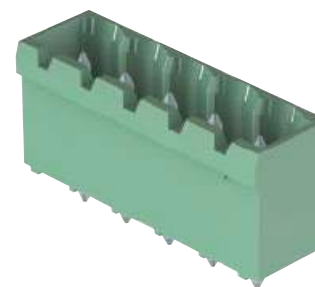

Identification	No. of contacts	Part number	Packaging unit (pieces)
PCB connectors male, vertical			
	2	14 13 021 . 001 000	100
	3	14 13 031 . 001 000	100
	4	14 13 041 . 001 000	75
	5	14 13 051 . 001 000	75
	6	14 13 061 . 001 000	50
	7	14 13 071 . 001 000	50
	8	14 13 081 . 001 000	50
	9	14 13 091 . 001 000	50
	10	14 13 101 . 001 000	50
	11	14 13 111 . 001 000	50
	12	14 13 121 . 001 000	50
Please insert digit for pitch 5.00 mm ▶ 6 pitch 5.08 mm ▶ 7			
Coding keys		14 95 000 0051 000	120

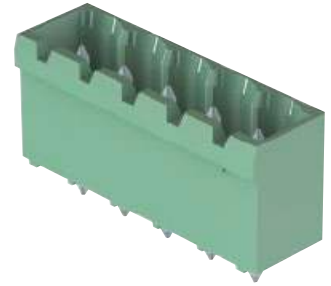

PCB connectors male,
vertical
for wave soldering
pitch 5.00 / 5.08 mm

Drawing

Dimensions in mm

Dimensions

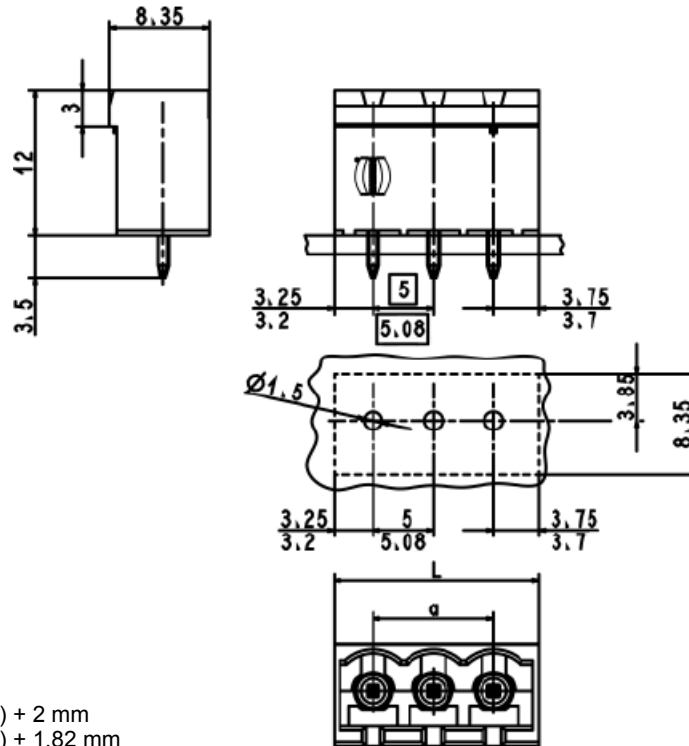

Pitch 5.00 mm: L = (pitch x poles) + 2 mm
Pitch 5.08 mm: L = (pitch x poles) + 1,82 mm

Technical characteristics

Technical data

Rated current 15 A
Pitch 5.00 mm / 5.08 mm

Surge voltage category /
pollution degree

III/3	III/2	II/2
250 V	300 V	600 V
4 kV	4 kV	4 kV

Rated voltage

Rated surge voltage

Material data

Group of insulation material I
Type of insulation material PA
Flammability rating per UL 94 V0
Operating temperature -40 °C ... +110 °C
Contact material copper alloy
Contact plating tin plated
UL approval (E 102079)



Solder pin data

Solder pin: drilled hole diameter 1.5 mm

Approval data (UL)

Use group	B	C	D
Rated voltage	300 V	–	300 V
Rated current	15 A	–	15 A

PCB connectors male,
vertical/horizontal
for reflow soldering
pitch 5.00 / 5.08 mm



Identification	No. of contacts	Part number	Packaging unit (pieces)
----------------	-----------------	-------------	-------------------------

PCB connectors male,
vertical/horizontal

2	14 12 021 . 00	100
3	14 12 031 . 00	100
4	14 12 041 . 00	75
5	14 12 051 . 00	75
6	14 12 061 . 00	50
7	14 12 071 . 00	50
8	14 12 081 . 00	50
9	14 12 091 . 00	50
10	14 12 101 . 00	50
11	14 12 111 . 00	50
12	14 12 121 . 00	50
13	14 12 131 . 00	50
14	14 12 141 . 00	50
15	14 12 151 . 00	50
16	14 12 161 . 00	50
17	14 12 171 . 00	50
18	14 12 181 . 00	50
19	14 12 191 . 00	50
20*	14 12 201 . 00	50

Please insert digit for

- pitch 5.00 mm ▶ 6
- pitch 5.08 mm ▶ 7
- vertical ▶ 1
- horizontal ▶ 2

Coding keys

14 95 000 0051 000

120

* Not available in pitch 5.00 mm (horizontal)

for samples (1 piece)
for a packaging unit



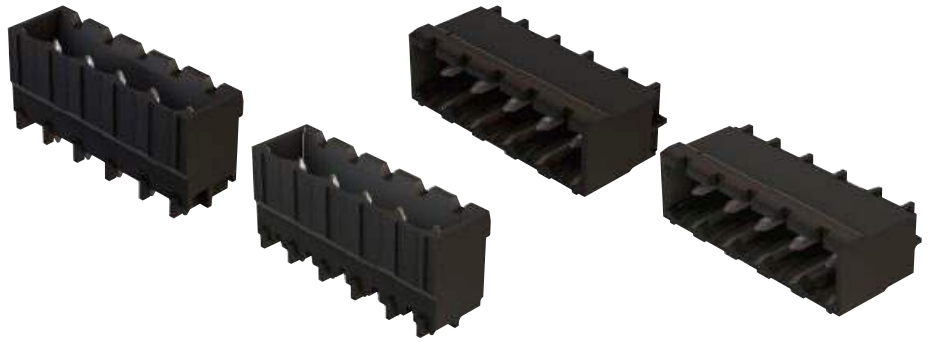

PCB connectors male, vertical/horizontal for reflow soldering pitch 5.00 / 5.08 mm

Drawing

Dimensions in mm

Dimensions

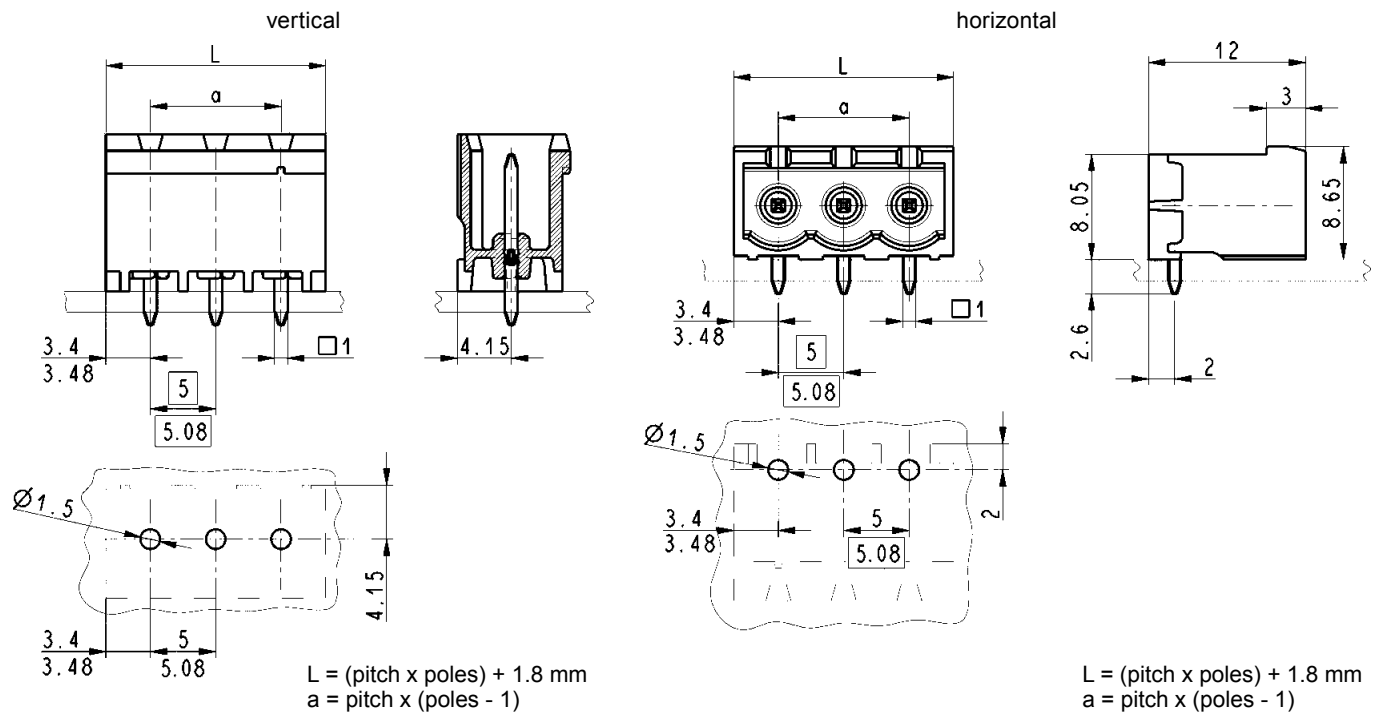

Technical characteristics

Technical data

Rated current 15 A
Pitch 5.00 mm / 5.08 mm

Surge voltage category / pollution degree	III/3	III/2	II/2
Rated voltage	250 V	300 V	600 V
Rated surge voltage	4 kV	4 kV	4 kV

Material data

Group of insulation material I
Type of insulation material PA / PPA
Flammability rating per UL 94 V0
Operating temperature -40 °C ... +110 °C
Contact material copper alloy
Contact plating tin plated
UL approval (E 102079)



Solder pin data

Solder pin: drilled hole diameter 1.5 mm

Approval data (UL)

Use group	B	C	D
Rated voltage	300 V	–	300 V
Rated current	15 A	–	15 A

PCB connectors male
with thread flange,
vertical/horizontal
for reflow soldering
pitch 5.08 mm



Drawing

Dimensions in mm

Dimensions

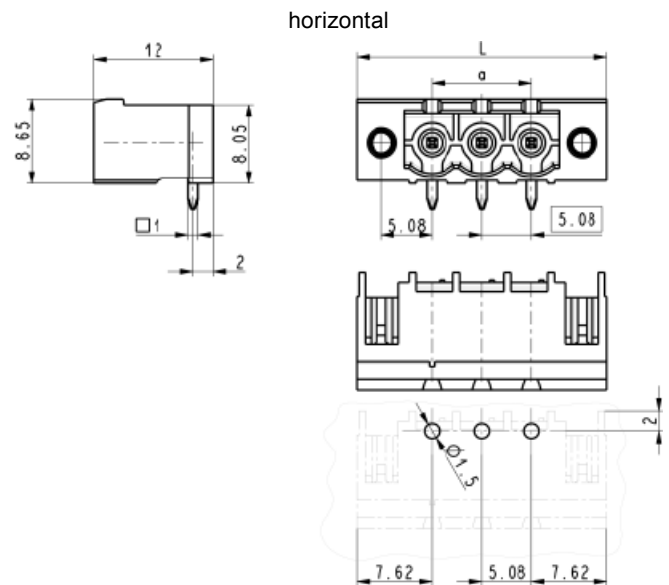
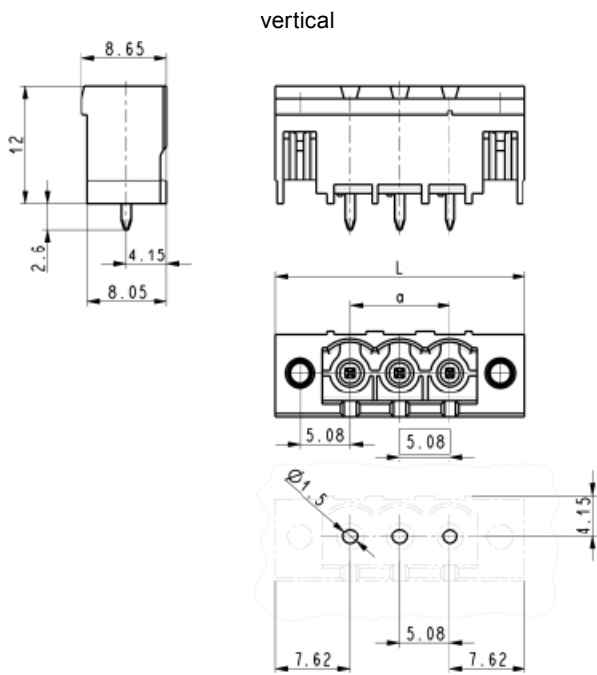

L = pitch x (poles + 2)
a = pitch x (poles - 1)

L = pitch x (poles + 2)
a = pitch x (poles - 1)

Technical characteristics

Technical data

Rated current 15 A
Pitch 5.08 mm

Surge voltage category / pollution degree	III/3	III/2	II/2
Rated voltage	250 V	300 V	600 V
Rated surge voltage	4 kV	4 kV	4 kV

Solder pin data

Solder pin: drilled hole diameter 1.4 mm

Material data

Group of insulation material I
Type of insulation material PA / PPA
Flammability rating per UL 94 V0
Operating temperature -40 °C ... +110 °C
Contact material copper alloy
Contact plating tin plated
 UL approval (E 102079)
Thread flange M2.5

Approval data (UL)

Use group	B	C	D
Rated voltage	300 V	–	300 V
Rated current	15 A	–	15 A

PCB terminal blocks,
horizontal with screw termination
10 mm² / 25 mm²
for reflow soldering
pitch 10.16 / 15.00 mm

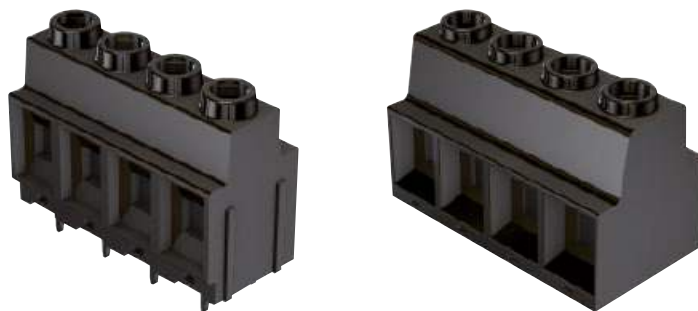

Identification	No. of contacts	Part number	Packaging unit (pieces)
PCB terminal blocks, stackable horizontal with screw termination			
For wire gauge 10 mm ² Pitch 10.16 mm 600 V 60 A	2	14 02 022 5402 000	50
	3	14 02 032 5402 000	50
	4	14 02 042 5402 000	40
For wire gauge 25 mm ² Pitch 15.00 mm 600 V 135 A	2	14 02 022 7402 000	50
	3	14 02 032 7402 000	40
	4	14 02 042 7402 000	30

Approval data (UL)

Use group		B	C	D
Rated voltage	Pitch 10.16 mm	300 V	300 V	600 V
	Pitch 15.00 mm	600 V	600 V	–
Rated current	Pitch 10.16 mm	60 A	60 A	60 A
	Pitch 15.00 mm	135 A	135 A	–

PCB terminal blocks,
horizontal with screw termination
10 mm² / 25 mm²
for reflow soldering
pitch 10.16 / 15.00 mm

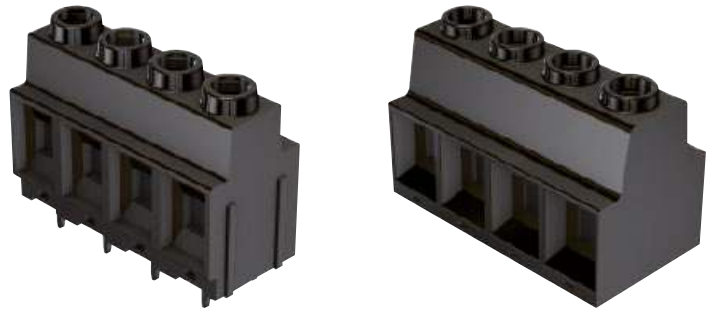

Drawing

Dimensions in mm

Dimensions

Pitch 10.16 mm

Pitch 15.00 mm

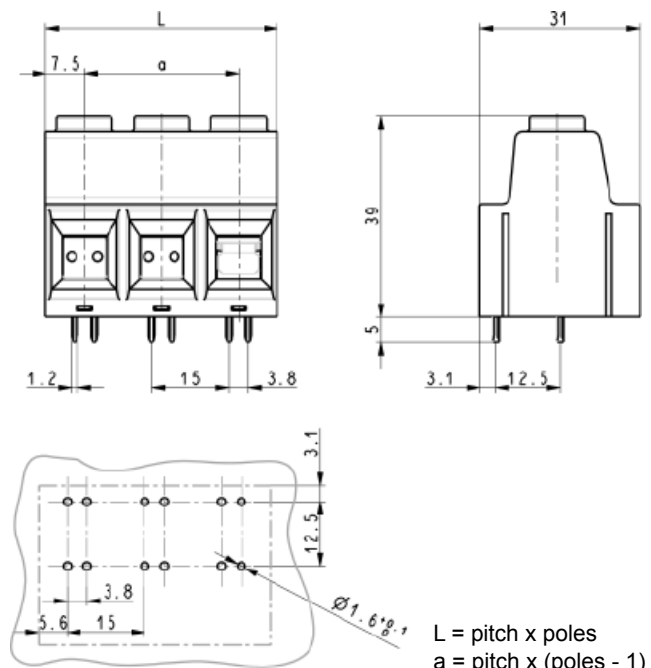
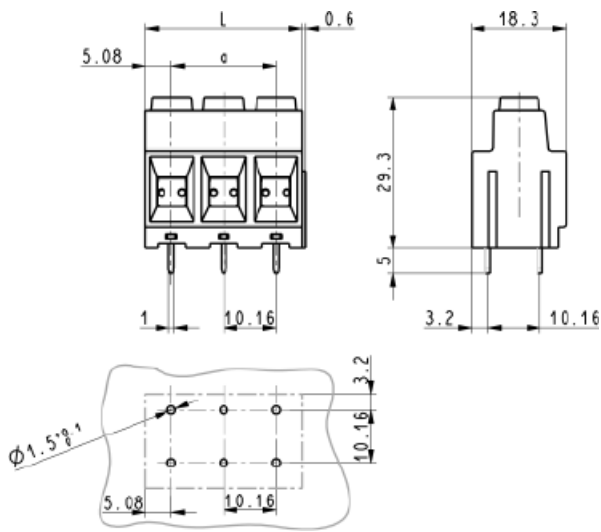

L = pitch x poles
a = pitch x (poles - 1)

L = pitch x poles
a = pitch x (poles - 1)

Technical characteristics

Technical data

Rated current 60 / 135 A
Pitch 10.16 / 15.00 mm

Surge voltage category /
pollution degree

III/3	III/2	II/2
1 kV	1 kV	1 kV
8 kV	8 kV	8 kV

Rated voltage

Rated surge voltage

Material data

Group of insulation material I
Type of insulation material PA / PPA
Flammability rating per UL 94 V0
Operating temperature -40 °C ... +110 °C
Contact material copper alloy
Contact plating tin plated
UL approval (E 102079)



Conductor and solder pin data

Pitch 10.16 mm

Pitch 15.00 mm

Connection technology wire screw termination

screw termination

screw termination

Conductor size

solid / stranded

stranded with ferrules without / with plastic sleeve

0.5 - 16 / 0.5 - 10 mm²

0.5 - 6 / 0.5 - 6 mm²

0.5 - 35 / 0.5 - 25 mm²

0.5 - 16 / 0.5 - 16 mm²

Conductor size AWG

20 - 6

20 - 1

Screw thread

M4

M5

Tightening torque

1.2 - 1.5 Nm

2.1 - 2.5 Nm

Stripping length

11 mm

18 mm

Solder pin: drilled hole diameter

min. 1.5 mm

min. 1.6 mm

Basic element for a reliable connection is besides the quality of the connector the right choice of the assembly tool. HARTING offers the corresponding tools to all connectors. On the following catalogue pages you find information about tools for crimp, press-in and IDC termination. There are tools available for different levels of automation. The choice varies from pure hand tools for small series or service up to fully automatic assembly tools for high volume series production.



Contents

Page





Tools for crimp contacts	20.02
Crimp tools for screened hoods	20.25
Tools for press-in contacts	20.26
Tools for insulation displacement contacts	20.41
Tools for FOC contacts	20.43

Tools for contacts Han D® (09 15 ...)

Identification	Part number	Drawing	Dimensions in mm
HARTING Service crimping tool with locator set for Han D®, Han E®	09 99 000 0021	Wire gauge Han D® 0.14 ... 1.5 mm ²	
BUCHANAN crimping tool	09 99 000 0888	Wire gauge 0.14 ... 2.5 mm ²	
HARTING crimping tool with locator for Han D®, Han E®, Han® C	09 99 000 0110	Wire gauge Han D® 0.14 ... 1.5 mm ²	
HARTING Pneumatic crimping tool CP 600	09 99 000 0810		
Crimp die Han D®, Han E®, Han® C	09 99 000 0813	Wire gauge Han D® 0.14 ... 1.5 mm ²	
Footswitch	09 99 000 0811		
Table fixing	09 99 000 0812		

1) For wire gauge 0.14 and 0.25 mm² use only male contact 09 15 000 6107 or female contact 09 15 000 6207.



Tools for contacts **Han D**® (09 15 ...)

Identification	Part number	Drawing	Dimensions in mm
Insertion tool for crimp contacts	09 99 000 0059	 <p>For crimp contacts with wires of less than 0.75 mm² it is recommended that an insertion tool is used. Contacts should be inserted from the wiring side and pushed down until a positive locking is achieved.</p>	
Removal tool for crimp contacts			
Removal tool	09 99 000 0012		
Replacement-tip for removal tool	09 99 000 0004		
Removal tool	09 99 000 0052	 <p>A removal tool is necessary if contacts are to be replaced in the insert. It is inserted from the mating face and pushed over the contact until a stop is noticeable. Additional pressure unlocks the contact and pushes it out of the wiring side. In case of the removal tool (. . 0052) the unlocking process is achieved by pressure on the central rod.</p>	

Tools for contacts Han E® (09 33 ...)

Identification	Part number	Drawing	Dimensions in mm
HARTING Service crimping tool with locator set for Han D®, Han E®	09 99 000 0021	Wire gauge Han E® 0.5 ... 2.5 mm ²	
BUCHANAN crimping tool	09 99 000 0888	Wire gauge 0.14 ... 4 mm ²	
HARTING crimping tool with locator for Han D®, Han E®, Han® C	09 99 000 0110	Wire gauge Han E® 0.5 ... 4 mm ²	
HARTING Pneumatic crimping tool CP 600	09 99 000 0810		
Crimp die Han D®, Han E®, Han® C	09 99 000 0813	Wire gauge Han E® 0.5 ... 4 mm ²	
Footswitch	09 99 000 0811		
Table fixing	09 99 000 0812		

Tools for contacts **Han E®** (09 33 ...)

Identification	Part number	Drawing	Dimensions in mm
Insertion tool for crimp contacts	09 99 000 0059	 <p>For crimp contacts with wires of less than 0.75 mm² it is recommended that an insertion tool is used. Contacts should be inserted from the wiring side and pushed down until a positive locking is achieved.</p>	
Insertion tool for Han® ES inserts	09 99 000 0367		
Removal tool for crimp contacts for Han® EE, Han® Q 5/0, Han® Q 8/0, Han E®, Han-Yellock® and Han A®	09 99 000 0319	 <p>A removal tool is necessary if contacts are to be replaced in the insert. The tool is inserted from the wiring side until a stop is noticeable. The wire with the crimp contact can then be pulled out from the same side of the insert.</p>	

Tools for contacts Han® C (09 32 ...)

Identification	Part number	Drawing	Dimensions in mm
BUCHANAN crimping tool	09 99 000 0888	Wire gauge 0.14 ... 4 mm ²	
HARTING crimping tool with locator for Han D®, Han E®, Han® C	09 99 000 0110	Wire gauge Han® C 1.5 ... 4 mm ²	
HARTING crimping tool with locator for Han® C	09 99 000 0303	Wire gauge 4 ... 6 mm ²	
Locator as spare part	09 99 000 0304		
HARTING crimping tool for Han® C	09 99 000 0377	Wire gauge 6 ... 10 mm ²	
HARTING Pneumatic crimping tool CP 600	09 99 000 0810		
Crimp die Han® C	09 99 000 0813	Wire gauge Han® C 1.5 ... 4 mm ²	
Crimp die Han® C	09 99 000 0814	Wire gauge Han® C 6 ... 10 mm ²	
Footswitch	09 99 000 0811		
Table fixing	09 99 000 0812		

Tools for contacts Han® C (09 32 ...)

Identification	Part number	Drawing	Dimensions in mm
----------------	-------------	---------	------------------

Removal tool for crimp contacts

Removal tool

1.5 ... 6 mm²
10 mm²

09 99 000 0305
09 99 000 0381





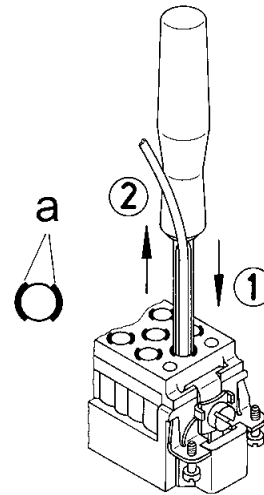

A removal tool is necessary to remove the contacts. For each „C“ contact cavity, the location of the internal locking levers are marked on the wiring side with two black arcs. The sides of the tool must be first properly aligned so that the edges of the tool engage both levers simultaneously and then inserted until a stop is noticeable ①. Once it has been inserted, the tool must not be turned. The wire together with the tool can then be pulled out from the wiring side of the insert ②.







a ... lever marking

Overview Han® crimping tools

Crimp contacts Series	Part number				mm ²	AWG	Crimping tools						Tools		
	male contact silver plated	female contact silver plated	male contact silver plated	female contact gold plated			09 99 000 0888	09 99 000 0110	09 99 000 0021	09 99 000 0303	09 99 000 0377	20 99 000 1035	removal tools		
Han D® Signal contacts 09 15 000 	6107	6207	6127	6227	0.14 - 0.25	26 - 24	x							09 99 000 0012	09 99 000 0052
	6104	6204	6124	6224						x	x				
	6107	6207	6127	6227	0.37	22	x								
	6104	6204	6124	6224					x	x	x				
	6103	6203	6123	6223	0.5	20	x	x	x						
	6105	6205	6125	6225	0.75	18	x	x	x						
	6102	6202	6122	6222	1.0	18	x	x	x						
	6101	6201	6121	6221	1.5	16	x	x	x						
6106	6206	6126	6226	2.5	14	x									
Han D® F.O. contacts 20 10 001	Male contact 3211 3212 / 3213		Female contact 3221 3222		1 mm POF							x			
Han E® Power contacts 09 33 000 	6127	6227	6117	6217	0.14 - 0.37	26 - 22	x						09 99 000 0319		
	6121	6220	6122	6222	0.5	20	x	x	x						
	6114	6214	6115	6215	0.75	18	x	x	x						
	6105	6205	6118	6218	1.0	18	x	x	x						
	6104	6204	6116	6216	1.5	16	x	x	x						
	6102	6202	6123	6223	2.5	14	x	x	x						
	6106	6206			3.0	12	x	x							
	6107	6207	6119	6221	4.0	12	x	x							
Han E® F.O. contacts 20 10 001	Male contact 3311		Female contact 3321		1 mm POF							x			
Han-Yellock® Power contacts 11 05 000 	6101	6201	6121	6221	0.14 - 0.37	26 - 22	x						09 99 000 0319		
	6102	6202	6122	6222	0.5	20	x	x	x						
	6103	6203	6123	6223	0.75	18	x	x	x						
	6104	6204	6124	6224	1.0	18	x	x	x						
	6105	6205	6125	6225	1.5	16	x	x	x						
	6106	6206	6126	6226	2.5	14	x	x	x						
	6107	6207	6127	6227	3.0	12	x	x							
	6108	6208	6128	6228	4.0	12	x	x							
Han® C Power contacts 09 32 000 	6104	6204			1.5	16	x	x					09 99 000 0305	09 99 000 0381 ¹⁾	
	6105	6205			2.5	14	x	x							
	6107	6207			4.0	12	x	x			x				
	6108	6208			6.0	10					x	x			
	6109	6209			10.0	8					x				
Description															
Locator Han D®	09 99 000 0022								x						
Locator Han E®	09 99 000 0022								x						
Locator Han-Yellock®	09 99 000 0341							x							
	09 99 000 0343								x						
Locator Han® C	09 99 000 0304										x				
Locator Han D®, Han E® and Han® C	09 99 000 0376							x							

 1) for Han® C power contacts, 10 mm²

Overview Han® crimping tools

Crimp contacts Series	Part number				mm ²	AWG	Crimping machines																
	male contact silver plated	female contact silver plated	male contact silver plated	female contact gold plated			09 99 000 0813 ³⁾	09 99 000 0814 ³⁾	09 98 000 6901 ¹⁾	09 98 000 6902 ¹⁾	09 98 000 8101	09 98 000 8102	09 98 000 8103	09 98 000 8107 ⁵⁾	09 98 000 9001	09 98 000 9002	09 98 000 9003						
Han D® Signal contacts 09 15 000 	6107	6207	6127	6227	0.14 - 0.25	26 - 24																	
	6104	6204	6124	6224					x														
	6107	6207	6127	6227	0.37	22																	
	6104	6204	6124	6224					x	x	x												
	6103	6203	6123	6223	0.5	20	x	x	x														
	6105	6205	6125	6225	0.75	18	x	x	x														
	6102	6202	6122	6222	1.0	18	x	x	x														
	6101	6201	6121	6221	1.5	16	x	x	x														
6106	6206	6126	6226	2.5	14			x															
Han E® Power contacts 09 33 000 	6127	6227	6117	6217	0.14 - 0.37	26 - 22						x ⁶⁾	x ⁶⁾								x		
	6121	6220	6122	6222	0.5	20	x					x	x									x	
	6114	6214	6115	6215	0.75	18	x					x	x									x	
	6105	6205	6118	6218	1.0	18	x					x	x									x	
	6104	6204	6116	6216	1.5	16	x					x	x									x	
	6102	6202	6123	6223	2.5	14	x					x	x									x	
	6106	6206			3.0	12	x					x	x									x	
	6107	6207	6119	6221	4.0	12	x					x	x									x	
Han-Yellock® Power contacts 11 05 000 	6101	6201	6121	6221	0.14 - 0.37	26 - 22															x ⁶⁾		
	6102	6202	6122	6222	0.5	20	x															x	
	6103	6203	6123	6223	0.75	18	x															x	
	6104	6204	6124	6224	1.0	18	x															x	
	6105	6205	6125	6225	1.5	16	x															x	
	6106	6206	6126	6226	2.5	14	x															x	
	6107	6207	6127	6227	3.0	12	x																
	6108	6208	6128	6228	4.0	12	x																
Han® C Power contacts 09 32 000 	6104	6204			1.5	16	x															x	
	6105	6205			2.5	14	x																x
	6107	6207			4.0	12	x																x
	6108	6208			6.0	10																	x
	6109	6209			10.0	8																	x
Description																							
Locator Han-Yellock®	09 99 000 0344						x																

Tooling

1) For using changeable units 09 98 000 6901 / 6902 the TK-M basic machine 09 98 000 6900 is required.
 3) For using of tool head the basic unit CP 600 (09 99 000 0810) is required.

4) Only male contacts
 5) For using changeable units 09 98 000 8101 - 8107 the TC-SC basic machine 09 98 000 8000 is required.
 6) depending on the wire



Crimping machine TC-C01

Features

- Basic unit in compact construction for pre-stripped wire
- Simple handling due to ergonomic design
- For individual, turned male and female contacts
- Selective processing of male and female HARTING contacts (wire gauge from 0.14 mm² to 10.0 mm², AWG 26 to AWG 8)
- Automatic contact feed
- Reproducible, top quality gas-tight crimp connections
- Non-slip, anti-vibration adjustable feet for setting the height
- Low noise level
- Can be transported with carrying handle
- Removable electric and pneumatic supply connections
- Maintenance interval counter
- Minimal setup effort
- Crimping depth can be set without tools
- Low maintenance costs
- Low follow-up costs for maintenance and repair
- Easy replacement of wearing components

Technical characteristics

Dimensions:	
Height	345 mm
Width	230 mm
Depth	400 mm
Total weight:	app. 24 kg
Local noise level:	62 dB (A)
Electrical connection:	230 V, 50 Hz
Power rating:	0.20 kW
Compressed air connection:	6 bar
Control system:	PLC
Work cycle trigger:	Footswitch
Machine work cycle:	1 second
Crimp type:	Four-point crimping
Contact feed:	Vibratory bowl feed
Stroke counters:	Resettable daily counter and permanent counter

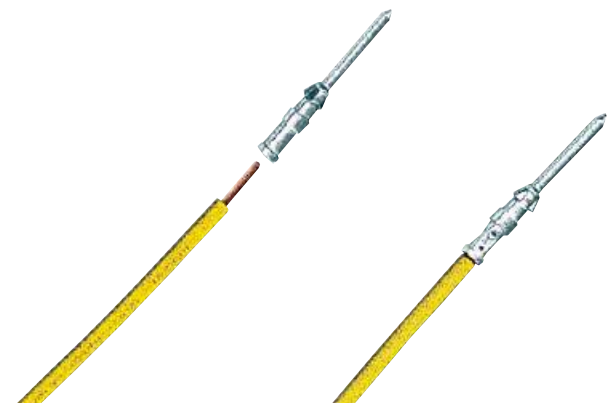

Crimping machine TC-C01

Identification

Part number

Crimping machine TC-C01

for Han D® contacts
 Han E® contacts
 Han® C contacts

09 98 000 9001
 09 98 000 9002
 09 98 000 9003



Included in the delivery

Options

- Crimping machine TC-C01
 - with 2.0 m connection cable and grounding plug
 - with 2.0 m pneumatic hose, quick-release coupling and N6 plug-in nipple
- Footswitch
- Carrying handle
- Operating instructions
- Declaration of conformity

Pneumatic maintenance unit





Crimping machine TK-M

Features

Technical characteristics

- ❑ Fast stripping and crimping in one operation
- ❑ Basic unit in compact construction
- ❑ Simple handling because of well-arranged construction with touchscreen controlling
- ❑ For individual, turned male and female contacts (for the HARTING series Han D®, Han E®)
- ❑ Selective processing of male and female contacts (Wire gauge from 0.14 mm² to 4.0 mm², AWG 26 to AWG 12)
- ❑ Contact magazine with filling control
- ❑ Reproducible, top quality gas-tight crimp connections
- ❑ Infinitely variable adjustment parameters
 - Stripping depth
 - Stripping length
 - Crimping depth
 - Crimp contact feed rate
- ❑ Rotatable vibration feeder and actuator in basic unit
- ❑ Low noise level
- ❑ For oil-free compressed air
- ❑ Very low setup effort
- ❑ Low maintenance costs of the modular construction

Dimensions:	
Height	580 mm
Width	470 mm
Depth	470 mm
Total weight:	Approx. 60 kg
Local noise level:	< 75 dB (A)
Drive:	Electro-pneumatic
Electrical connection:	230 V, 50 Hz
Power rating:	Approx. 0,75 kW
Pneumatic pressure:	6 bar
Compressed air connection:	3 dm ³ / work cycle
Control system:	PLC
Work cycle trigger:	Sensor
Machine work cycle:	1.5 seconds (stripping and crimping)
Crimp type:	Four-notch crimping
Contact feed:	Vibratory bowl feed
Stroke counters:	Resettable daily counter and quantity preselection



Crimping machine TK-M

Identification

Part number

Crimping machine TK-M
(Basic machine
without interchangeable unit)

09 98 000 6900

Interchangeable units for Han D®
Han E®

09 98 000 6901
09 98 000 6902



Pack contents

- Crimping machine TK-M
 - with one mounted interchangeable unit
 - with 2.0 m connection cable and grounding plug
 - with 2.0 m pneumatic hose with plug-in nipple N6
- Plug gauges for setting the crimping
- Centering bush for positioning the plug gauges
- Drawer for holding the contacts when the magazine is emptied
- Draw for insulation remains
- Tool set for setting
- 1 set of stripping blades
- Operating instructions
- Declaration of conformity

Options

Interchangeable unit

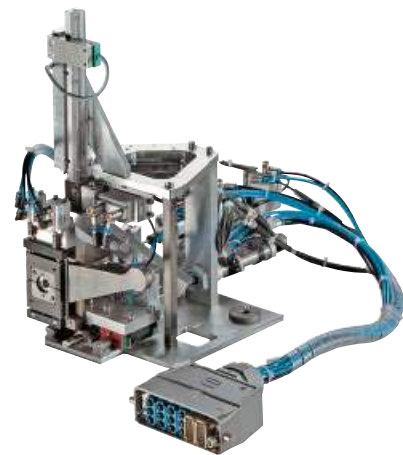



Crimping machine TC-SC

Features

- ❑ Fast stripping and crimping in one operation
- ❑ Basic unit in compact construction
- ❑ Simple handling because of well-arranged construction with touchscreen controlling
- ❑ For individual, turned male and female contacts (for the HARTING series Han D®, Han E®, Han® C, Han P®, Han-Yellock®, D- Sub)
- ❑ Selective processing of male and female contacts (Wire gauge from 0.14 mm² to 10.0 mm², AWG 28 to AWG 8)
- ❑ Contact magazine with filling control
- ❑ Reproducible, top quality gas-tight crimp connections
- ❑ Motor-driven variable adjustment parameters
 - Stripping depth
 - Stripping length
 - Crimping depth
 - Wire position
- ❑ Infinitely variable adjustment parameters
 - Wire retention force
 - Crimp contact feed rate
- ❑ Low noise level
- ❑ For oil-free compressed air
- ❑ Very low setup effort
- ❑ Low maintenance costs of the modular construction

Technical characteristics

Dimensions:	
Height	480 mm
Width	650 mm
Depth	560 mm
Total weight:	Approx. 75 kg
Local noise level:	< 75 dB (A)
Drive:	Electro-pneumatic
Electrical connection:	230 V, 50 Hz
Power rating:	1.0 kW
Pneumatic pressure:	6 bar
Compressed air connection:	3 dm ³ / work cycle
Control system:	PLC
Work cycle trigger:	Sensor
Machine work cycle:	2 seconds (stripping and crimping)
Crimp type:	Four-notch crimping
Contact feed:	Vibratory bowl feed
Stroke counters:	Resettable daily counter and quantity preselection



Crimping machine TC-SC

Identification

Part number

Crimping machine TC-SC

(Basic machine
without interchangeable unit)

09 98 000 8000



Interchangeable units for Han D®

Han E®

Han® C

D-Sub

D-Sub

Han P®

Han-Yellock®

09 98 000 8101

09 98 000 8102

09 98 000 8103

09 98 000 8104

09 98 000 8105

09 98 000 8106

09 98 000 8107

Crimp tool for Han® C

09 98 300 8103

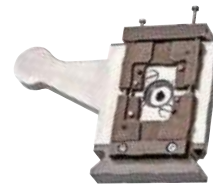

Pack contents

- Crimping machine TC-SC
 - with one mounted interchangeable unit
 - with 2.0 m connection cable and grounding plug
 - with 2.0 m pneumatic hose with plug-in nipple N6
- Tool set for adjustments
- 1 set of stripping blades
- Operating instructions
- Declaration of conformity

Options

Interchangeable unit

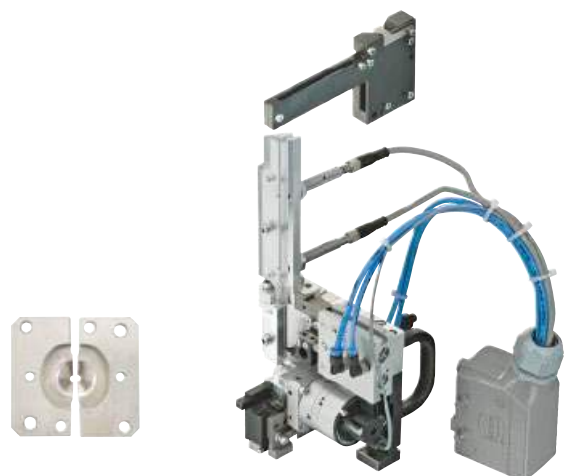



Crimping machine BK

Features

Technical characteristics

- Fast stripping and crimping in one operating
- Simple handling by quick change tool and stripper
- For HARTING crimp contacts D-Sub
- Selectives processing of male and female contacts
- Wire gauges from 0.09 mm² up to 0.5 mm², AWG 28 up to AWG 20
- Hand wheel for manual adjustments
- Maintenance-friendly through needle bearing rail
- Automatic exhaust of the isolation remainders
- Produces consistent high quality gas tight crimp connections
- With crimp force monitor
- Setting parameters with raster rotary button
 - Depth of insulation stripping
 - Length of insulation stripping
 - Crimping height on wire
 - Crimping height on insulation
 - Wire retainer position
 - Band thrust
 - Wire position in the crimp contact
- Non slip and anti-vibration feet
- Low noise level
- For unlubricated compressed air
- Low maintenance costs

Dimensions	
Height	690 mm / 1400 mm with a contact reel
Width	420 mm
Depth	430 mm
Total weight	
	approx. 72 kg
Localized noise level	
	85 dB (A)
Drive	
	electro pneumatic
Power supply	
	230 V, 50/60 Hz, 2.5 A
Consumption	
	0.75 kW
Pneumatic pressure	
	6 bar
Control system	
	PLC
Stripping device	
	Typ 514
Suction apparatus	
	2000.0900.20
Work cycle trigger	
	Sensor
Work cycle	
	0.35 s.
Illumination	
	integrated tool light 20001326
Motor speed	
	440 –2000 rpm
Stroke counter	
	Daywise and fixed

Crimping machine BK

Identification

Part number

Crimping machine BK
(without quick change tool)

09 98 000 5000



Quick change tool for
D-Sub (AWG 28-24)
D-Sub (AWG 24-20)
D-Sub high density (AWG 26-24)

09 98 000 3008
09 98 000 3009
09 98 000 3012





Pack contents

- Crimping machine BK
 - with role owner and guide plate
 - with 2.0 m connection cable and shockproof plug
 - with 2.0 m pneumatic hose with plug-in nipple N9
- Oiler bottle for the lubricating of the crimping contacts
- Tool set for setting
- 1 set of stamps for wire and isolation-crimp
- 1 anvil one-piece for wire and isolation-crimp
- 1 set of stripping blades
- 1 litre of contact oil
- Operating instructions
- Declaration of conformity

Options

V-Blades for special wires
on request

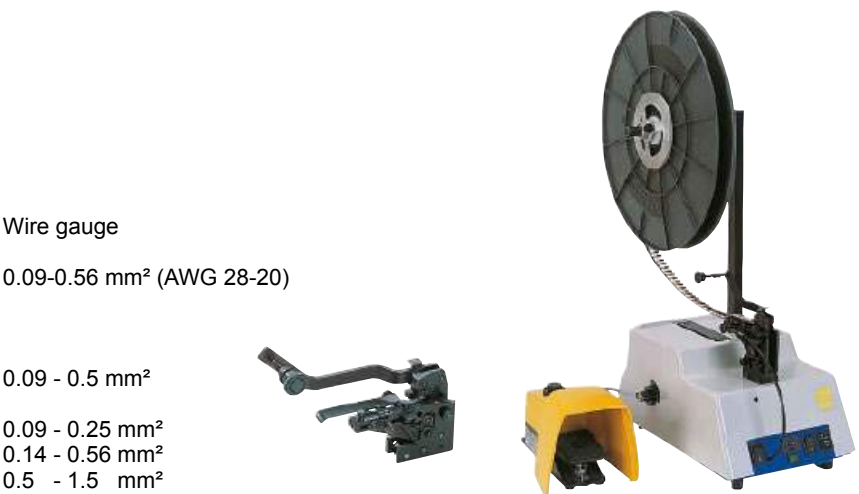
Tools for crimp termination – D-Sub-S, D-Sub-HD, DIN 41 612

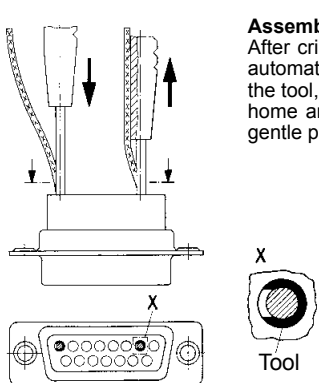
Identification	Part number	
<p>Service crimp tool</p> <p>for single D-Sub standard contacts</p> <p>for single D-Sub high density contacts</p>	<p>09 99 000 0175</p> <p>09 99 000 0535</p>	 <p>for standard contacts</p> <p>for high density contacts</p>
<p>HARTING-Crimp tool</p> <p>for 500 bandoliered D-Sub standard contacts</p> <p>for 500 bandoliered D-Sub high density contacts</p>	<p>09 99 000 0169</p> <p>09 99 000 0597</p>	
<p>HARTING-Semi-automatic crimping device</p> <p>Main drive foot-operated 220 V / 50 Hz</p> <p>Crimping head for bandoliered D-Sub standard contacts</p> <p>for DIN 41 612 contacts, types BC / har-bus® 64</p> <p>FC 1 FC 2 FC 3</p> <p>BC / har-bus® 64</p> <p>Reel holder for 10 000 contacts</p>	<p>09 99 000 0246</p> <p>09 99 000 0253</p> <p>09 99 000 0252</p> <p>09 99 000 0249</p> <p>09 99 000 0250</p> <p>09 99 000 0251</p> <p>09 99 000 0628</p> <p>09 99 000 0158</p>	<p>Wire gauge</p> <p>0.09-0.56 mm² (AWG 28-20)</p> <p>0.09 - 0.5 mm²</p> <p>0.09 - 0.25 mm²</p> <p>0.14 - 0.56 mm²</p> <p>0.5 - 1.5 mm²</p> <p>0.13 mm² (solid wire)</p> 
<p>Insertion and removal tool</p> <p>for single D-Sub standard contacts</p> <p>for single D-Sub high density contacts</p>	<p>09 99 000 0171</p> <p>09 99 000 0513</p>	 <p>Assembly of crimp contacts After crimping the stranded wire to the contact using a hand tool or automatic crimping device, insert the contact into the chamber with the tool, working from the wiring side. You will hear the contacts snap home and to check that they are securely in place, give the wire a gentle pull.</p> <p>Removing crimp contacts Position the tool from the wiring side as shown in the diagram below and insert into the contact chamber. The contact can then easily be removed from the wiring side together with the wire itself and reinserted in a different chamber. The tool is designed for a maximum insulation diameter of Ø 1.7 mm.</p>  <p>Stripping length: 2.5 + 0.5 mm</p>

Tools for crimp termination – D-Sub-S, D-Sub-HD

Identification

Part number

Crimp tool
for turned male
and female contacts
AWG 28-18
4 indent crimp
in acc. to
MIL 22 520/2-01

09 99 000 0501



Contact Part No.	Gauge	Crimp tool selection No.
09 67 000 3x76	AWG 18, 20, 22	6 for AWG 18 and AWG 20, 5 for AWG 22
09 67 000 8x76	AWG 20, 22, 24	6
09 67 000 5x76	AWG 22, 24, 26	6
09 67 000 7x76	AWG 24, 26, 28	6

Locator for crimp tool
Details see table

09 99 000 0531



printing

USE WITH CONTACTS

HARTING
09 67 000 xxxx

	Selector					
AWG	18	20	22	24	26	28
18-22	6	6	5	-	-	-
20-24	-	6	6	6	-	-
22-26	-	-	6	6	6	-
24-28	-	-	-	6	6	6

Tools for crimp termination – D-Sub-M

Identification	Part number	Drawing																																													
<p>Hand crimp tool for signal contacts</p> <p>Die (To be ordered separately)</p>	<p>09 99 000 0501</p> <p>09 99 000 0531</p>	<p>printing</p> <p>USE WITH CONTACTS HARTING 09 67 000 xxxx</p> <table border="1"> <thead> <tr> <th colspan="2"></th> <th colspan="4">Selector</th> </tr> <tr> <th>AWG</th> <th>18</th> <th>20</th> <th>22</th> <th>24</th> <th>26</th> <th>28</th> </tr> </thead> <tbody> <tr> <td>18-22</td> <td>6</td> <td>6</td> <td>5</td> <td>-</td> <td>-</td> <td>-</td> </tr> <tr> <td>20-24</td> <td>-</td> <td>6</td> <td>6</td> <td>6</td> <td>-</td> <td>-</td> </tr> <tr> <td>22-26</td> <td>-</td> <td>-</td> <td>6</td> <td>6</td> <td>6</td> <td>-</td> </tr> <tr> <td>24-28</td> <td>-</td> <td>-</td> <td>-</td> <td>6</td> <td>6</td> <td>6</td> </tr> </tbody> </table> <p>Wire gauge AWG 18 – 28</p>			Selector				AWG	18	20	22	24	26	28	18-22	6	6	5	-	-	-	20-24	-	6	6	6	-	-	22-26	-	-	6	6	6	-	24-28	-	-	-	6	6	6				
		Selector																																													
AWG	18	20	22	24	26	28																																									
18-22	6	6	5	-	-	-																																									
20-24	-	6	6	6	-	-																																									
22-26	-	-	6	6	6	-																																									
24-28	-	-	-	6	6	6																																									
<p>Hand crimp tool for power contacts</p> <p>Positioner for male and female contacts (To be ordered separately)</p> <p>Positioner for male contacts (To be ordered separately.)</p> <p>Positioner for female contacts (To be ordered separately.)</p>	<p>09 99 000 0509</p> <p>09 99 000 0504</p> <p>09 99 000 0522</p> <p>09 99 000 0521</p>	<table border="1"> <thead> <tr> <th>Contact Part No.</th> <th>Gauge</th> <th>Tool setting</th> </tr> </thead> <tbody> <tr> <td>09 69 182 x420</td> <td>AWG 16, 18, 20</td> <td>3 for AWG 16, 2 for AWG 18 and AWG 20</td> </tr> <tr> <td>09 69 282 x420</td> <td>AWG 16, 18, 20</td> <td>3 for AWG 16, 2 for AWG 18 and AWG 20</td> </tr> <tr> <td>09 69 182 x421</td> <td>AWG 12, 14</td> <td>5 for AWG 12 and 4 for AWG 14</td> </tr> <tr> <td>09 69 282 x421</td> <td>AWG 12, 14</td> <td>5 for AWG 12 and 4 for AWG 14</td> </tr> <tr> <td>09 69 182 x422</td> <td>AWG 10, 12</td> <td>7 for AWG 10 and 6 for AWG 12</td> </tr> <tr> <td>09 69 282 x422</td> <td>AWG 10, 12</td> <td>7 for AWG 10 and 6 for AWG 12</td> </tr> <tr> <td>09 69 182 x423</td> <td>AWG 8, 10</td> <td>7 for AWG 8 and 6 for AWG 10</td> </tr> <tr> <td>09 69 282 x423</td> <td>AWG 8, 10</td> <td>7 for AWG 8 and 6 for AWG 10</td> </tr> </tbody> </table> <table border="1"> <thead> <tr> <th>Contact Part No.</th> <th>Gauge</th> <th>Tool setting</th> </tr> </thead> <tbody> <tr> <td>09 69 282 x821</td> <td>AWG 12, 14</td> <td>5 for AWG 12 and 4 for AWG 14</td> </tr> <tr> <td>09 69 282 x823</td> <td>AWG 8, 10</td> <td>7 for AWG 8 and 6 for AWG 10</td> </tr> </tbody> </table> <table border="1"> <thead> <tr> <th>Contact Part No.</th> <th>Gauge</th> <th>Tool setting</th> </tr> </thead> <tbody> <tr> <td>09 69 182 x821</td> <td>AWG 12, 14</td> <td>5 for AWG 12 and 4 for AWG 14</td> </tr> <tr> <td>09 69 182 x823</td> <td>AWG 8, 10</td> <td>7 for AWG 8 and 6 for AWG 10</td> </tr> </tbody> </table>	Contact Part No.	Gauge	Tool setting	09 69 182 x420	AWG 16, 18, 20	3 for AWG 16, 2 for AWG 18 and AWG 20	09 69 282 x420	AWG 16, 18, 20	3 for AWG 16, 2 for AWG 18 and AWG 20	09 69 182 x421	AWG 12, 14	5 for AWG 12 and 4 for AWG 14	09 69 282 x421	AWG 12, 14	5 for AWG 12 and 4 for AWG 14	09 69 182 x422	AWG 10, 12	7 for AWG 10 and 6 for AWG 12	09 69 282 x422	AWG 10, 12	7 for AWG 10 and 6 for AWG 12	09 69 182 x423	AWG 8, 10	7 for AWG 8 and 6 for AWG 10	09 69 282 x423	AWG 8, 10	7 for AWG 8 and 6 for AWG 10	Contact Part No.	Gauge	Tool setting	09 69 282 x821	AWG 12, 14	5 for AWG 12 and 4 for AWG 14	09 69 282 x823	AWG 8, 10	7 for AWG 8 and 6 for AWG 10	Contact Part No.	Gauge	Tool setting	09 69 182 x821	AWG 12, 14	5 for AWG 12 and 4 for AWG 14	09 69 182 x823	AWG 8, 10	7 for AWG 8 and 6 for AWG 10
Contact Part No.	Gauge	Tool setting																																													
09 69 182 x420	AWG 16, 18, 20	3 for AWG 16, 2 for AWG 18 and AWG 20																																													
09 69 282 x420	AWG 16, 18, 20	3 for AWG 16, 2 for AWG 18 and AWG 20																																													
09 69 182 x421	AWG 12, 14	5 for AWG 12 and 4 for AWG 14																																													
09 69 282 x421	AWG 12, 14	5 for AWG 12 and 4 for AWG 14																																													
09 69 182 x422	AWG 10, 12	7 for AWG 10 and 6 for AWG 12																																													
09 69 282 x422	AWG 10, 12	7 for AWG 10 and 6 for AWG 12																																													
09 69 182 x423	AWG 8, 10	7 for AWG 8 and 6 for AWG 10																																													
09 69 282 x423	AWG 8, 10	7 for AWG 8 and 6 for AWG 10																																													
Contact Part No.	Gauge	Tool setting																																													
09 69 282 x821	AWG 12, 14	5 for AWG 12 and 4 for AWG 14																																													
09 69 282 x823	AWG 8, 10	7 for AWG 8 and 6 for AWG 10																																													
Contact Part No.	Gauge	Tool setting																																													
09 69 182 x821	AWG 12, 14	5 for AWG 12 and 4 for AWG 14																																													
09 69 182 x823	AWG 8, 10	7 for AWG 8 and 6 for AWG 10																																													
<p>Hand crimp tool for coaxial contacts, solder/crimp version¹⁾</p> <p>Die (To be ordered separately)</p> <p>Die (To be ordered separately)</p> <p>Die (To be ordered separately)</p>	<p>09 99 000 0503</p> <p>09 99 000 0508</p> <p>09 99 000 0515</p> <p>09 99 000 0519</p>	<table border="1"> <thead> <tr> <th>Contact Part No.</th> <th>Cavity</th> </tr> </thead> <tbody> <tr> <td>09 69 181 x230</td> <td rowspan="2">B</td> </tr> <tr> <td>09 69 281 x230</td> </tr> <tr> <td>09 69 181 x141</td> <td rowspan="2">C</td> </tr> <tr> <td>09 69 281 x141</td> </tr> <tr> <td>09 69 181 x140</td> <td rowspan="2">B</td> </tr> <tr> <td>09 69 281 x140</td> </tr> </tbody> </table> <table border="1"> <thead> <tr> <th>Contact Part No.</th> <th>Cavity</th> </tr> </thead> <tbody> <tr> <td>09 69 181 x143</td> <td rowspan="2">A</td> </tr> <tr> <td>09 69 281 x143</td> </tr> </tbody> </table> <table border="1"> <thead> <tr> <th>Contact Part No.</th> <th>Cavity</th> </tr> </thead> <tbody> <tr> <td>09 69 181 x233</td> <td rowspan="2">B</td> </tr> <tr> <td>09 69 281 x233</td> </tr> </tbody> </table>	Contact Part No.	Cavity	09 69 181 x230	B	09 69 281 x230	09 69 181 x141	C	09 69 281 x141	09 69 181 x140	B	09 69 281 x140	Contact Part No.	Cavity	09 69 181 x143	A	09 69 281 x143	Contact Part No.	Cavity	09 69 181 x233	B	09 69 281 x233																								
Contact Part No.	Cavity																																														
09 69 181 x230	B																																														
09 69 281 x230																																															
09 69 181 x141	C																																														
09 69 281 x141																																															
09 69 181 x140	B																																														
09 69 281 x140																																															
Contact Part No.	Cavity																																														
09 69 181 x143	A																																														
09 69 281 x143																																															
Contact Part No.	Cavity																																														
09 69 181 x233	B																																														
09 69 281 x233																																															

¹⁾ Only the outer ferrule is crimped (inner conductor is soldered)

Tools for crimp termination – D-Sub-M

Identification

Part number

Hand crimp tool

for **coaxial** contacts, crimp/crimp version¹⁾, suitable for **inner** contact

09 99 000 0501



Inner contact die (To be ordered separately)

09 99 000 0507



Contact Part No.
09 69 182 x140
09 69 282 x140
09 69 182 x230
09 69 282 x230
09 69 182 x232
09 69 282 x232
09 69 182 x233
09 69 282 x233

Hand crimp tool for **coaxial** contacts, crimp/crimp version¹⁾, suitable for **outer** ferrule

09 99 000 0503



Outer contact die (To be ordered separately)

09 99 000 0508



Contact Part No.	Cavity
09 69 182 x140	B
09 69 282 x140	
09 69 182 x230	B
09 69 282 x230	

Contact Part No.	Cavity
09 69 182 x232	A
09 69 282 x232	

Outer contact die (To be ordered separately)

09 99 000 0519

Contact Part No.	Cavity
09 69 182 x233	B
09 69 282 x233	

¹⁾ Both inner and outer conductor are crimped

Tools for crimp termination – D-Sub-M

Identification

Part number

Hand crimp tool
for **high voltage**
contacts

09 99 000 0501



Contact Part No.	Gauge	Tool setting
09 69 182 2550	AWG 24, 26, 28, 30	5 for AWG 24 and 26, 4 for AWG 28 and 3 for AWG 30
09 69 282 2550	AWG 24, 26, 28, 30	5 for AWG 24 and 26, 4 for AWG 28 and 3 for AWG 30

Die for male and
female contacts
(To be ordered
separately.)

09 99 000 0533



Extraction tool
for **coaxial**,
pneumatic,
power and **high**
voltage contacts

09 99 000 0512



Tools for crimp termination – InduCom

Identification

Part number

Hexagonal head screwdriver
for hoods with hexagonal screws

61 03 600 0021



Crimp tool
for flange and ferrule

61 03 600 0020



Inserts for crimp tool

61 03 000 0179
61 03 000 0180
61 03 000 0098
61 03 000 0099
61 03 000 0100
61 03 000 0101
61 03 000 0102
61 03 000 0103
61 03 000 0104
61 03 000 0105
61 03 000 0174
61 03 000 0172
61 03 000 0168
61 03 000 0169
61 03 000 0175
61 03 000 0176
61 03 000 0177
61 03 000 0178
61 03 000 0173

Width of
hexagonal
nut [mm]

5.0
5.5
6.0
6.5
7.0
7.5
8.0
8.5
9.0
9.5
10.0
10.5
11.0
11.5
12.0
12.5
13.0
13.5
14.0

Mounting tool
for flange

for D-Sub hoods (9-37 contacts)
for D-Sub hoods (50 contacts)

61 03 600 0017
61 03 600 0018



Insertion and removal tool
for contacts

09 99 000 0171





Tool / Assembly instructions

Identification	No. of contacts	Part number	Drawing	Dimensions in mm
Crimp tool for screened hoods		09 99 000 0233		
Crimp tool dies	9	09 99 000 0235		
	15	09 99 000 0235		
	25	09 99 000 0236		
	37	09 99 000 0237		

Assembly instructions for screened hoods

Place the metal screen part (A) on the cable.
Prepare the cable for termination.

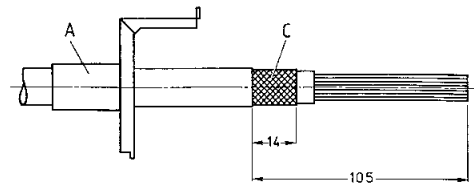

Place the inner ferrule (B) between conductors and the outer braid (C).

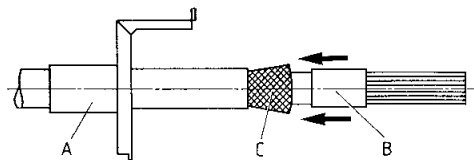

Terminate the D-Sub connector.
Put the metal screen part (A) over the braid and crimp directly over the inner ferrule, ensuring that the correct crimp tool die is used.
Slide in the other metal screen part (D).

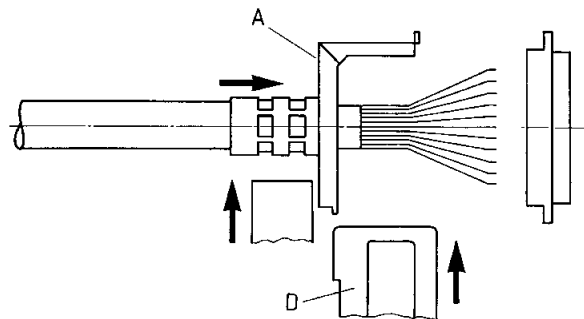

Push back the terminated connector into the assembled screen.
Put the assembled connector, screen and knurled screws into the thermoplastic hood and snap closed.

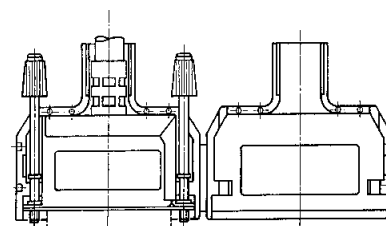

Modular tooling system for starting connector press-in

The diversity of connector types with press-in terminations and varying termination styles make it necessary to have a simple, flexible tooling system that can be continuously updated.

The HARTING modular tooling system has significant advantages in terms of economic assembly of the many connector types with press-in terminations. The basic modules of the tooling system which will always be required are:

- Press
- Top tool
- Bottom tool
- Base plate

To increase automation and productivity the following modules may be added to the basic assembly:

- Guide frame with base plate for accurate positioning of the pcb up to a length of 600 mm
- Guide frame "Standard" for hand bench press and pneumatic press and pcb height of 123.5 up to 309.5 mm
- Guide frame "Long" for pneumatic press and pcb height of 123.5 up to 668.5 mm

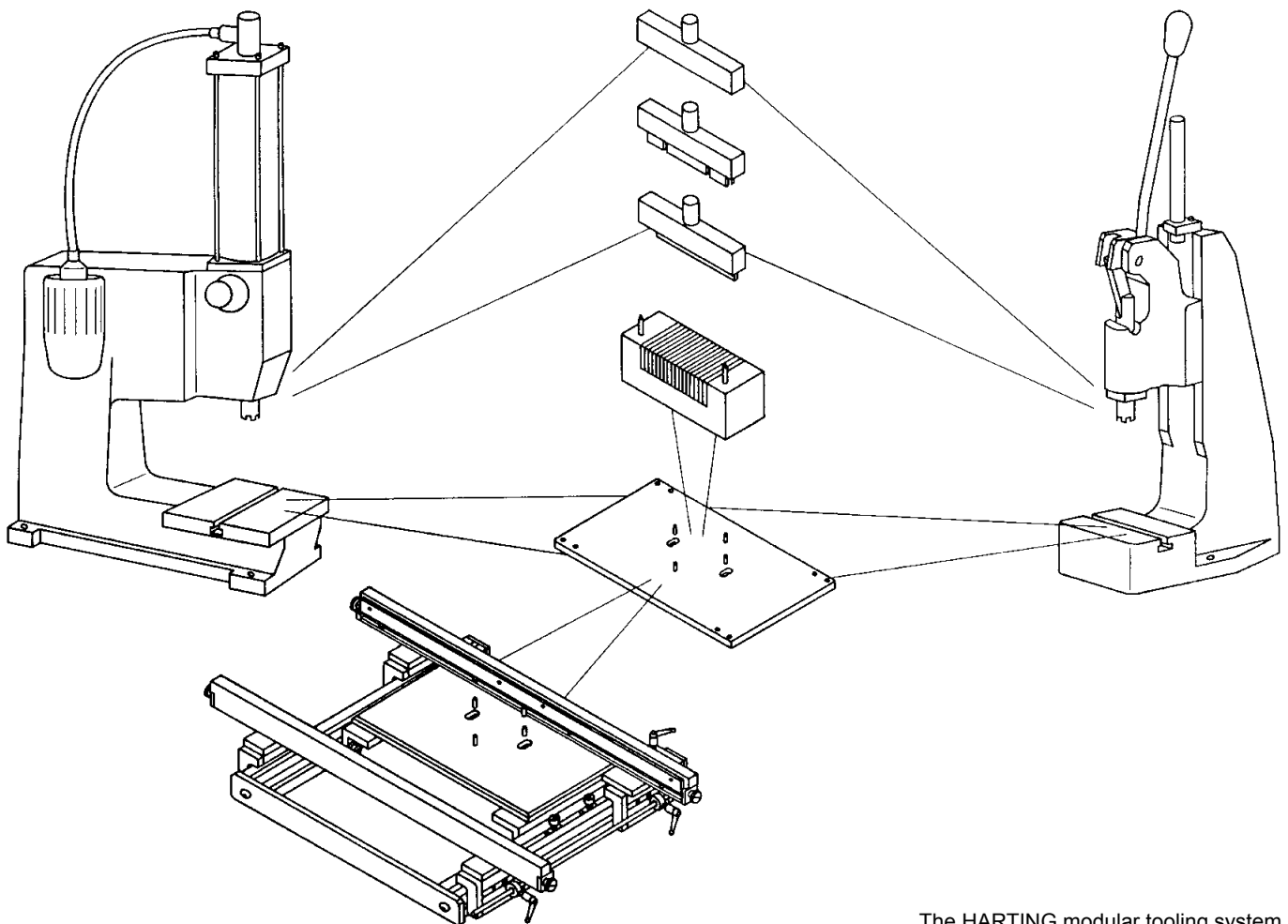

Handling indications

When setting up an assembly machine it is not necessary to set the working height of the press and adjust the base plate more than once. There is no need for further adjustments. All the other adaptations for various applications are performed efficiently and are reliant by various combinations of individual modules.

Positioning the bottom tool in relation to the top tool

The ram of the HARTING press is generally provided with a cross-shaped groove which accurately positions the top tool in steps of 90°.

Two guide pins position the bottom tool in relation to the top tool simply and accurately.

These guide pins cannot be used for positioning the pcb or the connector!

Two pairs of pins on the base plate locate the bottom tool in relation to the top tool in steps of 90°.

Height compensation

- Various overall heights of connectors are accommodated by type-specific top tools.
- Various pcb thicknesses are accommodated by the use of spacers between the bottom tool and base plate.

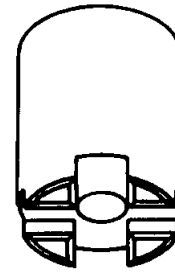

Ram with cross-shaped groove

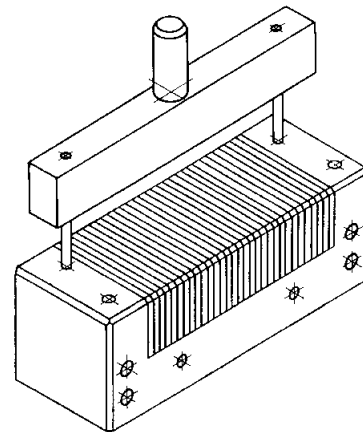

Positioning the bottom tool in relation to top tool

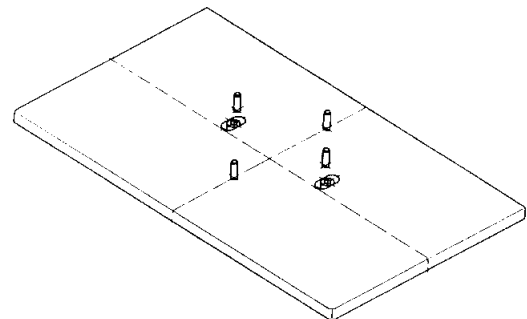

Base plate with pairs of location pins at 90°

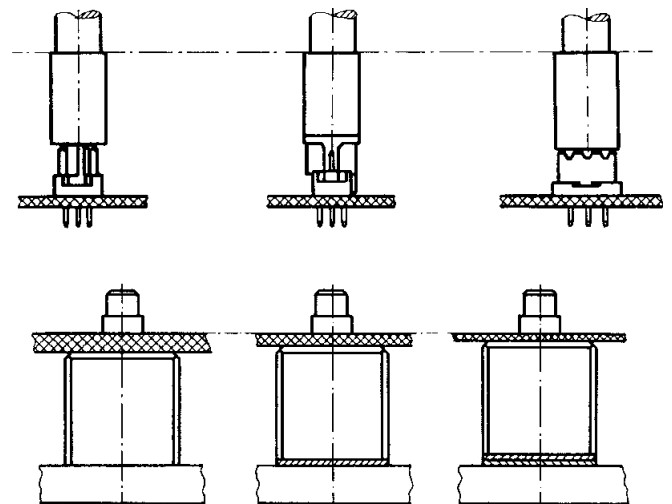

Handling indications

Range of applications for the bottom tool

One bottom tool can be used to assemble connectors with straight or angled press-in terminations.

When pressing in the connectors with angled press-in terminations the positioning pins remain in the bottom tool and serve as guide pins for the connector.

By rotating the bottom tool in steps of 90° and relocating the positioning pins it is possible to assemble half-length connectors with angled press-in terminations.

Bottom tool (narrow version)

In addition to the square bottom tool with multi-functional properties, HARTING offers the alternative of a narrow bottom tool for assembling connectors with straight press-in terminations. This tool supports the pcb within the press-in connector zone and therefore makes it possible to assemble connectors where electronic components are to be placed in close proximity.

Guide frame

The guide frame screwed to the base plate ensures the correct positioning of the pcb in relation to the top and bottom tools and permits a much higher rate of assembly.

Both guide rails are adjustable to accommodate various pcb sizes.

A spring-loaded supporting rail lifts the pcb away from the bottom tool after the press-in operation ensuring that no damage occurs to the conductors as it passes through the machine.

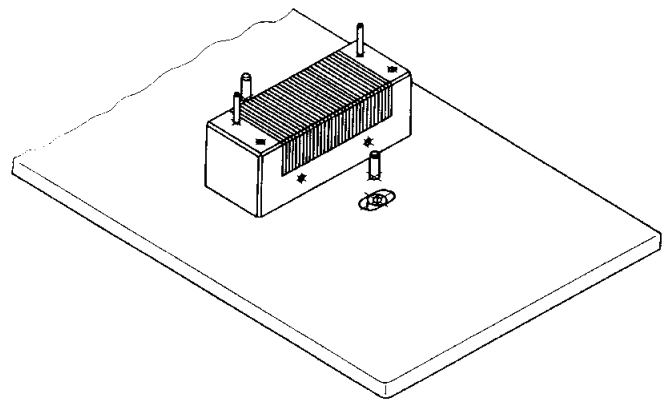

Bottom tool set for assembling connectors with angled pins

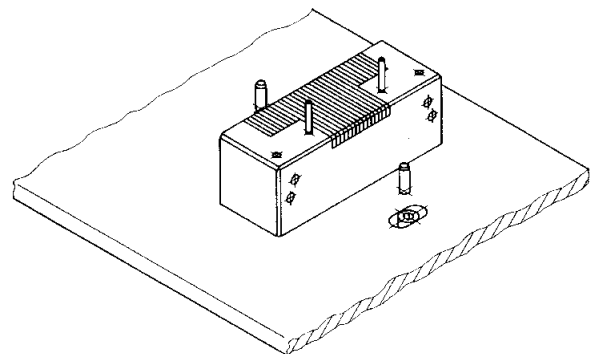

Bottom tool set for assembling half-length connectors with angled pins

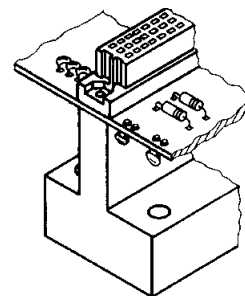

Narrow version of the bottom tool for special applications

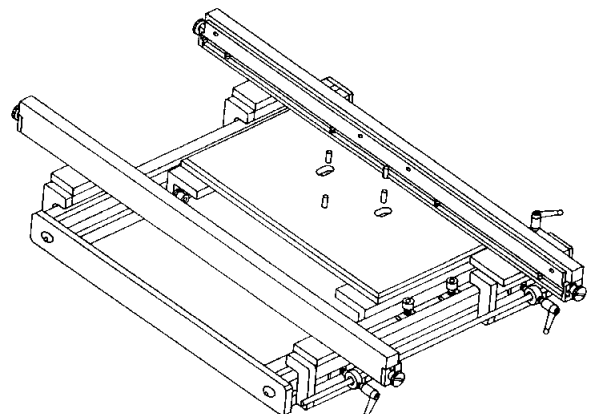

Guide frame for positioning the pcb in relation to the top and bottom tools

For a reliable and safe press-in process HARTING has developed a special tooling system. Each tooling is adapted to the special requirements of the individual connector range, thus a good handling and quick adjustment is guaranteed.

Identification	Part number	Drawing
Top tool for AdvancedTCA® B+ Bottom tool for AdvancedTCA® B+	16 99 000 0001 000 16 99 000 0002 000	 Top tool for AdvancedTCA® B+ Bottom tool for AdvancedTCA® B+
Top tool for MicroTCA™ Bottom tool for MicroTCA™	16 99 000 0003 000 16 99 000 0004 000	 Top tool for MicroTCA™ Bottom tool for MicroTCA™
Top tool for AdvancedTCA® Power Male and female connector Bottom tool for AdvancedTCA® Power Male and female connector	02 99 000 0002 16 99 000 0011 000	 Top tool for AdvancedTCA® Power and MicroTCA™ Power, module version Bottom tool for AdvancedTCA® Power
Top tool for MicroTCA™ Power Module version Backplane version Bottom tool for MicroTCA™ Power Module version Backplane version	02 99 000 0002 16 99 000 0008 000 16 99 000 0010 000 16 99 000 0009 000	 Top tool for MicroTCA™ Power, backplane version Bottom tool for MicroTCA™ Power, module version Bottom tool for MicroTCA™ Power, backplane version
Removal tool for AdvancedTCA® B+ Removal tool for MicroTCA™ Repair pliers for MicroTCA™	16 99 000 0005 000 16 99 000 0007 000 16 99 000 0006 000	 Removal tool for AdvancedTCA® B+ Removal tool for MicroTCA™ Repair pliers for MicroTCA™

Discrete tooling system – *harbus*® HM

For economical and safe press-in of *harbus*® HM connectors with 5+2 and 8+2 rows, HARTING has developed a discrete tooling system.

Due to its modular structure it can be adapted to any connector configuration that needs to be pressed-in extremely quickly and securely.

Therefore a top and a bottom tool for each connector style is available. These tools are inserted in a top or bottom carrier tool with a groove, thus guaranteeing exact position of the top and bottom tools and the connectors.

To use identical carrier tools for all connector configurations, HARTING offer spacer blocks to fill gaps between adjacent top or bottom tools.

The carrier tool is either completely filled with top or bottom tools or respective spacer blocks, making it possible to press-in single modules.

To press-in female connectors with pre-installed upper shields, separate top and bottom tools are available.

For lower shield press-in the tooling can be changed easily.

For further information please check our operating instructions or contact your HARTING representative.

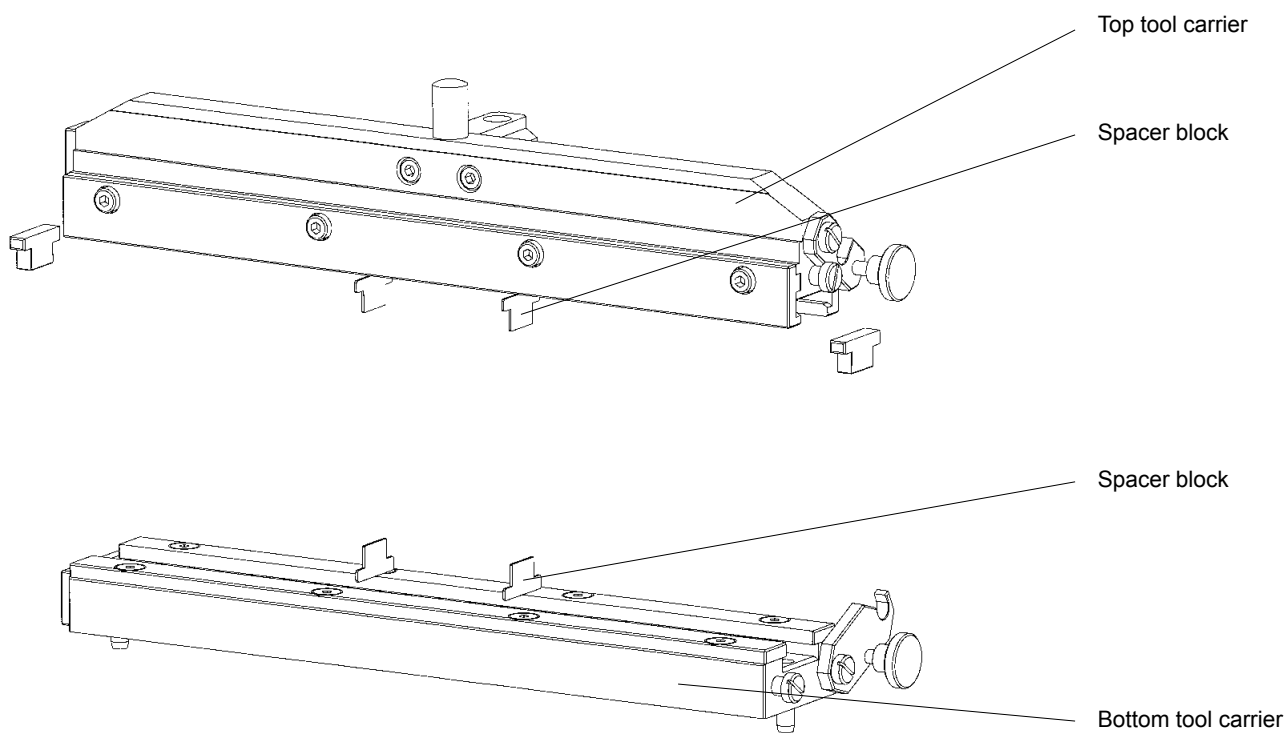

Basis tools of the discrete tooling system

Basis tools for all connector types

Part number connector	Tool identification	Part number tool	Part number connector	Tool identification	Part number tool
17 xx xxx xxxx	Top tool carrier	17 99 000 0012	17 xx xxx xxxx	Spacer block 25 mm	17 99 000 0055
17 xx xxx xxxx	Bottom tool carrier	17 99 000 0013	17 xx xxx xxxx	Spacer block 38 mm	17 99 000 0054
17 xx xxx xxxx	Top tool carrier 3U	17 99 000 0073	17 xx xxx xxxx	Spacer block 44 mm	17 99 000 0053
17 xx xxx xxxx	Bottom tool carrier 3U	17 99 000 0074	17 xx xxx xxxx	Spacer block 50 mm	17 99 000 0052
17 xx xxx xxxx	Spacer block 0.67 mm (CompactPCI)	17 99 000 0057	17 xx xxx xxxx	Centering plate female left	17 99 000 0060
17 xx xxx xxxx	Spacer block 5 mm	17 99 000 0056	17 xx xxx xxxx	Centering plate female right	17 99 000 0061

Discrete tooling system – *harbus*® HM

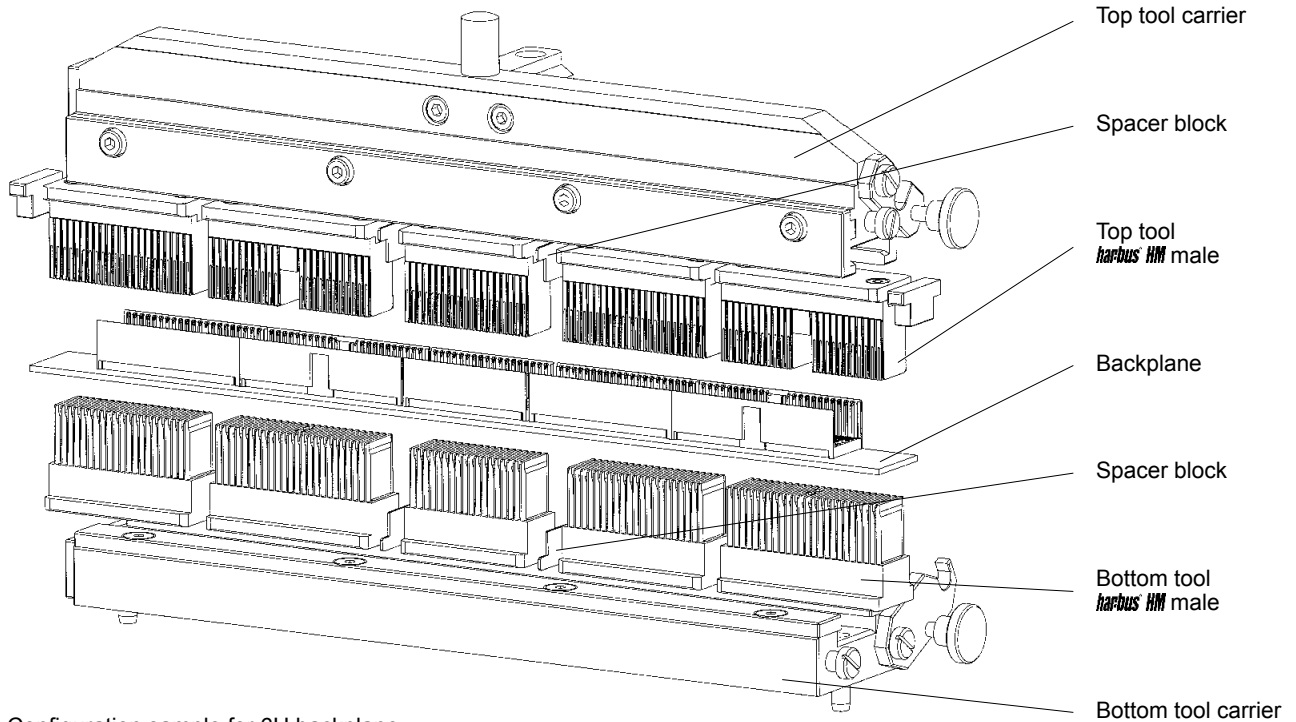

Configuration sample for 6U backplane

Tools for straight male connectors

Part number connector	Tool identification	Part number tool	Part number connector	Tool identification	Part number tool
17 01 xxx xxxx	Top tool, male, type A	17 99 000 0014	17 11 xxx xxxx	Top tool, male, type D	17 99 000 0022
17 01 xxx xxxx	Bottom tool, male, type A	17 99 000 0026	17 11 xxx xxxx	Bottom tool, male, type D	17 99 000 0028
17 02 xxx xxxx	Top tool, male, type B	17 99 000 0020	17 12 xxx xxxx	Top tool, male, type E	17 99 000 0023
17 02 xxx xxxx	Bottom tool, male, type B	17 99 000 0026	17 12 xxx xxxx	Bottom tool, male, type E	17 99 000 0028
17 04 xxx xxxx	Top tool, male, type B	17 99 000 0019	17 13 xxx xxxx	Top tool, male, type AB	17 99 000 0015
17 04 xxx xxxx	Bottom tool, male, type B	17 99 000 0025	17 13 xxx xxxx	Bottom tool, male, type AB	17 99 000 0024
17 05 xxx xxxx	Top tool, male, type B	17 99 000 0018	17 14 xxx xxxx	Top tool, male, type AB	17 99 000 0016
17 05 xxx xxxx	Bottom tool, male, type B	17 99 000 0024	17 14 xxx xxxx	Bottom tool, male, type AB	17 99 000 0025
17 03 xxx xxxx	Top tool, male, type C	17 99 000 0021	17 15 xxx xxxx	Top tool, male, type AB	17 99 000 0017
17 03 xxx xxxx	Bottom tool, male, type C	17 99 000 0027	17 15 xxx xxxx	Bottom tool, male, type AB	17 99 000 0026

Discrete tooling system – *harbus*® HM

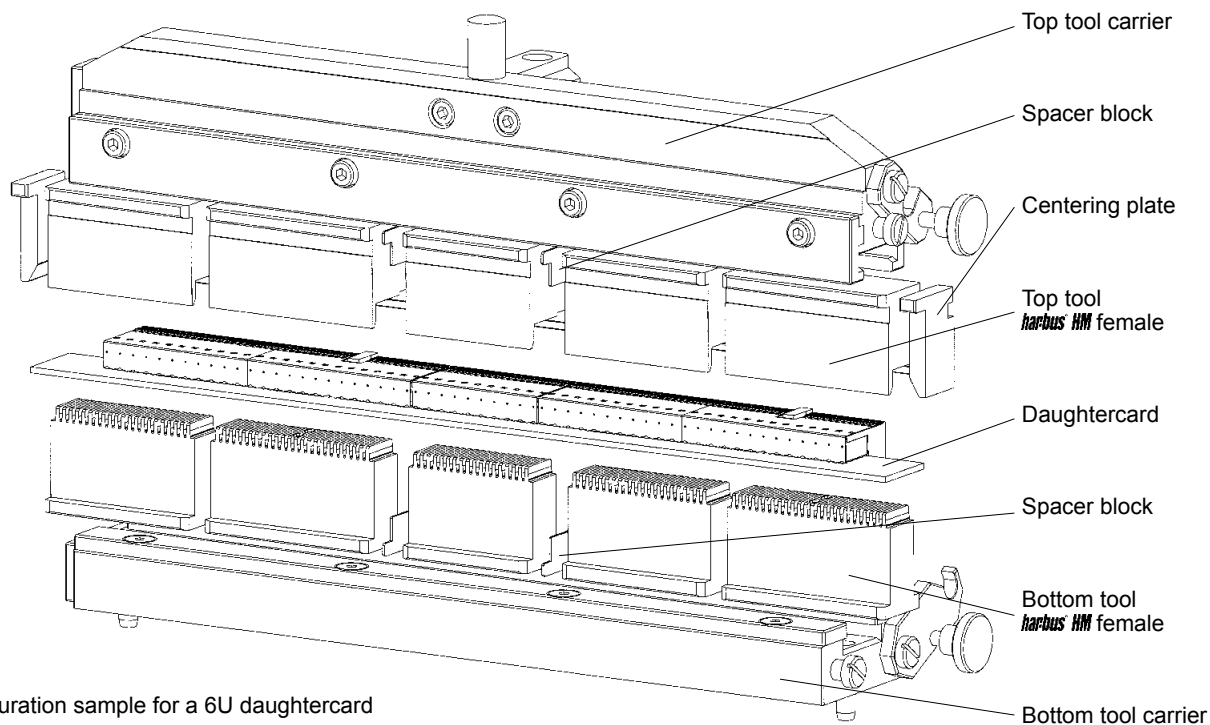

Configuration sample for a 6U daughtercard

Tools for angled female connectors

Part number connector	Tool identification	Part number tool	Part number connector	Tool identification	Part number tool
17 21 xxx xxxx	Top tool, female, type A	17 99 000 0029	17 31 xxx xxxx	Top tool, female, type D	17 99 000 0042
17 21 xxx xxxx	Bottom tool, female, type A	17 99 000 0046	17 31 xxx xxxx	Bottom tool, female, type D	17 99 000 0048
17 22 xxx xxxx	Top tool, female, type B	17 99 000 0038	17 32 xxx xxxx	Top tool, female, type E	17 99 000 0042
17 22 xxx xxxx	Bottom tool, female, type B	17 99 000 0046	17 32 xxx xxxx	Bottom tool, female, type E	17 99 000 0048
17 24 xxx xxxx	Top tool, female, type B	17 99 000 0036	17 33 xxx xxxx	Top tool, female, type AB	17 99 000 0032
17 24 xxx xxxx	Bottom tool, female, type B	17 99 000 0045	17 33 xxx xxxx	Bottom tool, female, type AB	17 99 000 0044
17 25 xxx xxxx	Top tool, female, type B	17 99 000 0034	17 34 xxx xxxx	Top tool, female, type AB	17 99 000 0058
17 25 xxx xxxx	Bottom tool, female, type B	17 99 000 0044	17 34 xxx xxxx	Bottom tool, female, type AB	17 99 000 0045
17 23 xxx xxxx	Top tool, female, type C	17 99 000 0040	17 35 xxx xxxx	Top tool, female, type AB	17 99 000 0029
17 23 xxx xxxx	Bottom tool, female, type C	17 99 000 0047	17 35 xxx xxxx	Bottom tool, female, type AB	17 99 000 0046

Tools for angled shielded female connectors

Part number connector	Tool identification	Part number tool	Part number connector	Tool identification	Part number tool
17 21 xxx xxxx	Top tool, female, type A upper shield	17 99 000 0030	17 34 xxx xxxx	Top tool, female, type AB upper shield	17 99 000 0059
17 21 xxx xxxx	Top tool, female, type A divided shield computer telephony	17 99 000 0031	17 35 xxx xxxx	Top tool, female, type AB upper shield	17 99 000 0030
17 22 xxx xxxx	Top tool, female, type B upper shield	17 99 000 0039	17 21 xxx xxxx	Press-in die lower shield type A	17 99 000 0051
17 24 xxx xxxx	Top tool, female, type B upper shield	17 99 000 0037	17 22 xxx xxxx	Press-in die lower shield type B	17 99 000 0051
17 25 xxx xxxx	Top tool, female, type B upper shield	17 99 000 0035	17 24 xxx xxxx	Press-in die lower shield type B	17 99 000 0050
17 23 xxx xxxx	Top tool, female, type C upper shield	17 99 000 0041	17 25 xxx xxxx	Press-in die lower shield type B	17 99 000 0049
17 31 xxx xxxx	Top tool, female, type D upper shield	17 99 000 0043	17 31 xxx xxxx	Press-in die lower shield type D	17 99 000 0051
17 32 xxx xxxx	Top tool, female, type E upper shield	17 99 000 0043	17 32 xxx xxxx	Press-in die lower shield type E	17 99 000 0051
17 33 xxx xxxx	Top tool, female, type AB upper shield	17 99 000 0033	17 33 xxx xxxx	Press-in die lower shield type AB	17 99 000 0049
			17 34 xxx xxxx	Press-in die lower shield type AB	17 99 000 0050
			17 35 xxx xxxx	Press-in die lower shield type AB	17 99 000 0051

Tooling for backplanes – *harbus*® HM

For 6U backplanes with CompactPCI configuration, HARTING has developed this start-up tooling.

The basis is a top tool carrier with tooth inserts, that are engaged alternately.

Therefore this tooling assembly can be used without any additional set-up time.

The tooth inserts are interchangeable, so that the tooling can be used for other connector configurations as well as for CompactPCI.

The bottom tool should preferably be a loadnest, which carries and aligns the pcb.

For detailed information please contact your local HARTING representative.

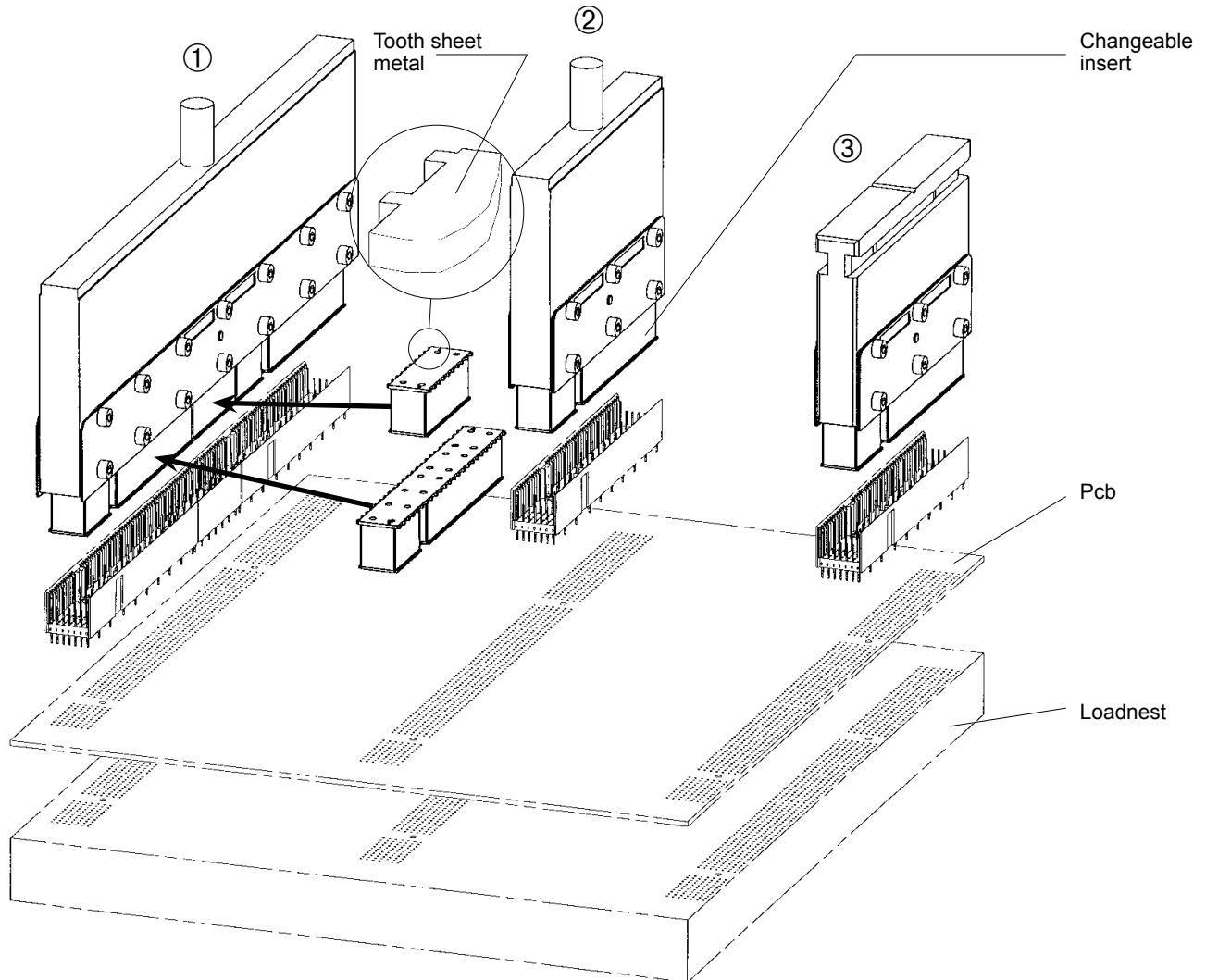

Configuration samples for CompactPCI backplanes

Tools for straight male connectors

Tool identification	Part number tool	Tool identification	Part number tool
① Insert top tool for 6U CompactPCI	17 99 000 0063	Tooth insert for type Monoblock 47	17 99 000 0066
② Insert top tool for 3U CompactPCI	17 99 000 0065		
③ Insert top tool for rotatable tool changer	on request	Tooth insert for type B 19 positions	17 99 000 0068

Insert blocks for male connectors – *harbus*[®] *HM*

The insert blocks can be used to press-in *harbus*[®] *HM* male connectors without any special top tool. These blocks will be put into the connectors manually or automatically.

To press-in the connector no precise position is needed and can be done by a simple flat rock die. This will accelerate the cycle time of the press-in process dramatically.

Insert blocks are developed for use with a loadnest.

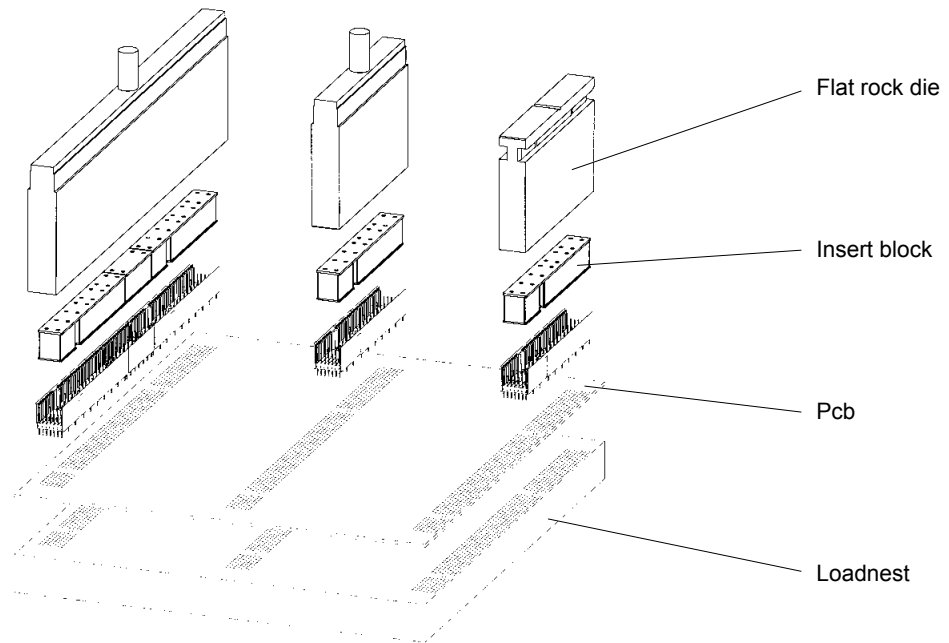

Application samples for insert blocks

Insert blocks for straight male connectors

Part number connector	Tool identification	Quantity and part number tool
17 01 xxx xxxx	Insert block for type A	1 x 17 99 000 0009 or (2 x 17 99 000 0001)
17 04 xxx xxxx	Insert block for type B	1 x 17 99 000 0004
17 05 xxx xxxx	Insert block for type B	1 x 17 99 000 0002
17 02 xxx xxxx	Insert block for type B	1 x 17 99 000 0003
17 03 xxx xxxx	Insert block for type C	1 x 17 99 000 0001
17 06 xxx xxxx	Insert block for type Monoblock 47	1 x 17 99 000 0008 or (1 x 17 99 000 0001 and 1 x 17 99 000 0005)
17 11 xxx xxxx	Insert block for type D	2 x 17 99 000 0006
17 12 xxx xxxx	Insert block for type E	1 x 17 99 000 0007
17 13 xxx xxxx	Insert block for type AB	1 x 17 99 000 0069
17 14 xxx xxxx	Insert block for type AB	1 x 17 99 000 0070
17 15 xxx xxxx	Insert block for type AB	1 x 17 99 000 0071
17 10 xxx xxxx	Insert block for type DE	1 x 17 99 000 0072



Flat rock dies

Part number connector	Tool identification	Part number tool
17 xx xxx xxxx	Flat rock die for 6U	07 79 000 0155
17 xx xxx xxxx	Flat rock die for 3U	07 79 000 0156

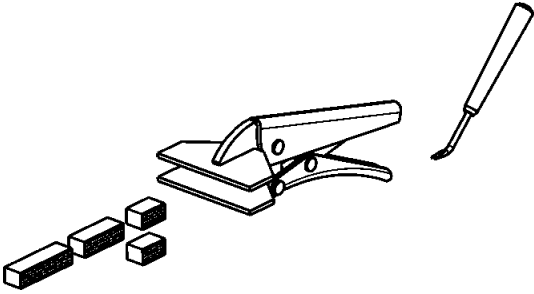
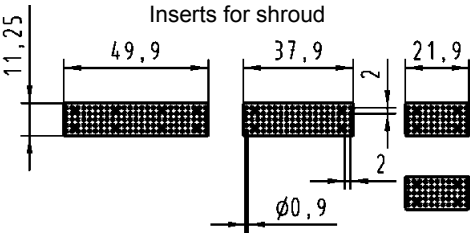
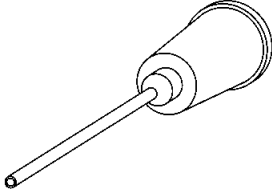

The insert block 17 99 000 0001 e.g. can be used for the types A, C and Monoblock 47.

Repair tooling – *harbus*® HM

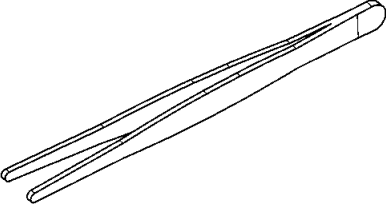
Identification	for use with	Part number	Drawing	Dimensions in mm
Tool kit shroud removal	<i>harbus</i> ® HM	17 99 000 0095		
				
Insertion and repair tool for single contact	<i>harbus</i> ® HM	17 99 000 0094		
Removal tool for single male contacts	<i>harbus</i> ® HM	09 99 000 0239		
Mounting tool for coding key	<i>harbus</i> ® HM	17 99 000 0093		

Tooling for angled male connectors – *harbus*® HM Power

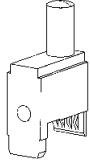
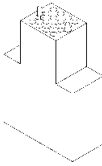
Identification	for use with	Part number	Drawing	Dimensions in mm
Top tool for angled male connectors	<i>harbus</i> ® HM Power	17 99 000 0102		
Bottom tool for angled male connectors	<i>harbus</i> ® HM Power	17 99 000 0103		

Discrete tooling system – **Mini Coax**

Straight Mini Coax connectors can be pressed-in with a flat die and a top tool delivered with the connectors. This top tool can be used as contact protection and remains in the connector until the daughtercard is mated.

Angled Mini Coax connectors will be pressed-in with separate top and bottom tools, which will be mounted into a common body.

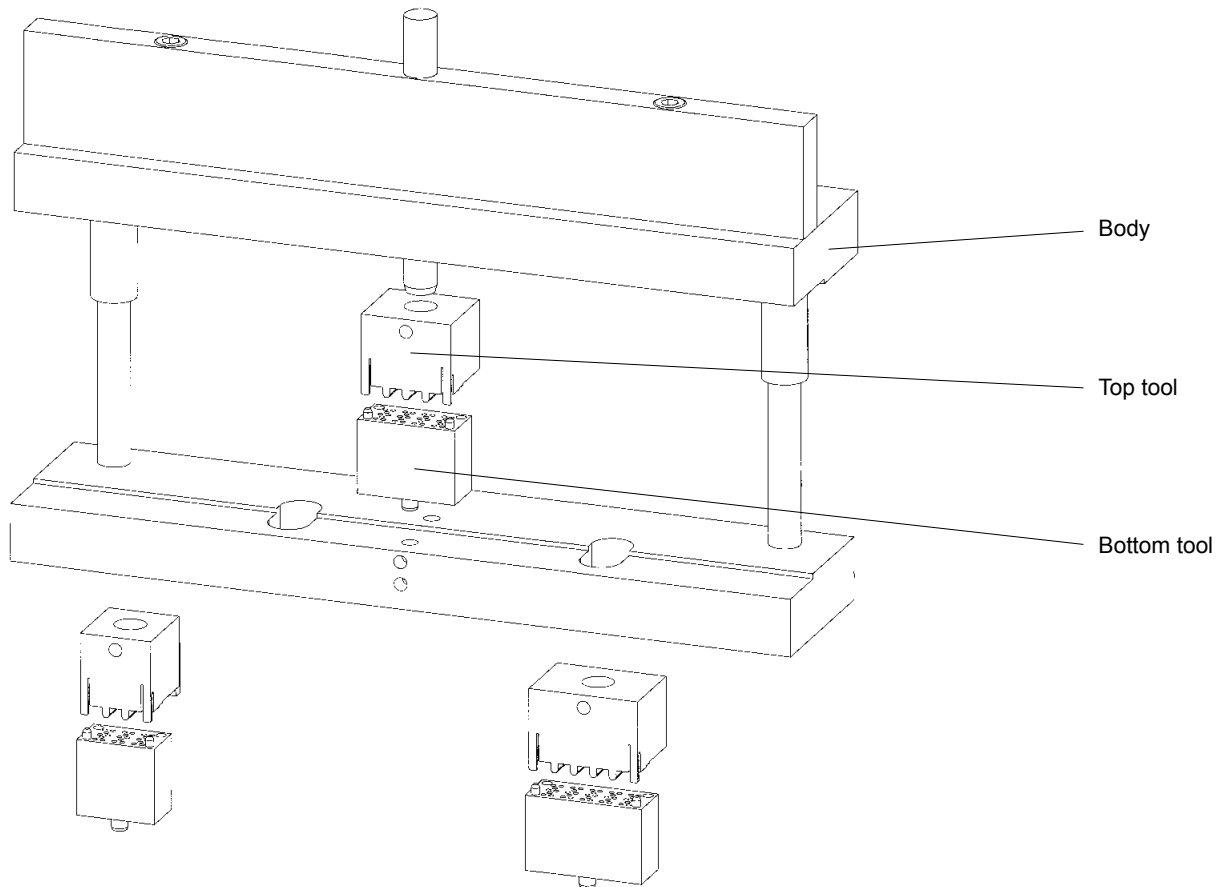

Configuration for angled modules

Tools for straight modules

Part number connector	Tool identification	Part number tool
07 11 xxx xxxx	1 SU Mini Coax Standard bottom tool	on request
07 11 xxx xxxx	1.25 SU Mini Coax Standard bottom tool	on request
07 11 xxx xxxx	1.50 SU Mini Coax Standard bottom tool	on request

Tools for angled modules

Part number connector	Tool identification	Part number tool
07 31 xxx xxxx	Body	07 79 000 0061
07 31 xxx xxxx	1 SU Mini Coax Standard bottom tool	07 79 000 0045
07 31 xxx xxxx	1 SU Mini Coax Standard top tool	07 79 000 0080
07 31 xxx xxxx	1.25 SU Mini Coax Standard bottom tool	07 79 000 0034
07 31 xxx xxxx	1.25 SU Mini Coax Standard top tool	07 79 000 0081
07 31 xxx xxxx	1.50 SU Mini Coax Standard bottom tool	07 79 000 0171
07 31 xxx xxxx	1.50 SU Mini Coax Standard top tool	07 79 000 0170
07 31 xxx xxxx	1 SU Mini Coax single-row bottom tool	07 79 000 0205
07 31 xxx xxxx	1 SU Mini Coax single-row top tool	07 79 000 0204

Hand bench presses / pneumatic presses

Identification	Part number	Drawing	Dimensions in mm
Hand bench press	09 99 000 0201		<p>Technical characteristics</p> <p>Working stroke 25 mm</p> <p>Press force 15 kN max.</p> <p>Hole \varnothing in the ram \varnothing 10 mm</p> <p>Net weight approx. 23 kg</p>
Pneumatic press 40 kN	09 99 000 0282		<p>Technical characteristics</p> <p>Total stroke 48 mm</p> <p>Working stroke 0-6 mm</p> <p>Press force 40 kN max.</p> <p>Air pressure 6 bar</p> <p>Hole \varnothing in the ram \varnothing 10.01 mm</p> <p>Net weight 136 kg</p> <p>Power supply 110 V / 220 V AC</p>
Adaptor for height compensation ¹⁾	09 99 000 0279		
Guide frame with base plate Standard type for pcb size x = 123,5 - 309,5 mm	09 99 000 0244		
Long type ²⁾ for pcb size x = 123,5 - 668,5 mm	09 99 000 0261		
Base plate	09 99 000 0255		

¹⁾ suitable for 09 99 000 0282 and all CPM machines
²⁾ not suitable for hand bench press

CPM press-in machines

CPM prestige



Part number **09 89 040 0000**

Technical characteristics

Drive	electro-mechanical, servo
Press-in force	100 kN
max. pcb dimensions	600 x 1000 mm
Floor space	1200 x 1150 mm
Weight	980 kg
Power supply	3x 208 / 380 / 400 / 415 V
Consumption	< 1 kW
Colour	on request

CPM prestige
(incl. PC, control software, barcode reader, keyboard, touch screen)

Built-in features:

- Guiding rails (carbon/spring-loaded) for the secure positioning of the pcb
- Touch-screen and Industrial PC with UPS (uninterruptable power supply)
- Barcode reader for management ease of press-in programs
- All dimensions allow an easy integration into production lines

Process monitoring and quality assurance:

- Touch screen interface with graphical and verbal menus for all machine functions
- Autosense: automated press-in interruption at incorrect press-in forces
- Storage and validation of all press-in parameters via quality assurance software (press-in force tolerances)
- Continuous high-precision measurement and recording of press-in forces and distances
- Remote determination of errors and maintenance
- High flexibility through a modular tool range

Options:

- Rotatable tool changer
- Insertion removal station

Insertion removal station





Power supply 220 V / 50 Hz
Air pressure 6 bar (15-16 l/min.)

Part number **on request**
for pcb dimensions
of max.
710 mm x 540 mm

Bestseller **CPM prestige with insertion removal station**, adaptable to all HARTING press-in machines.

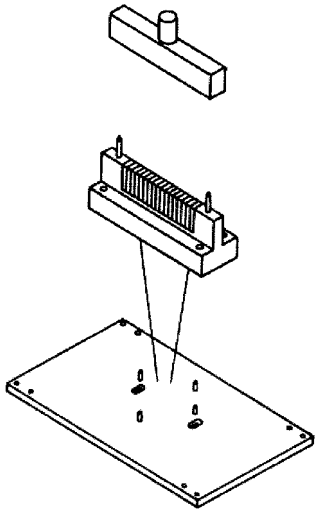
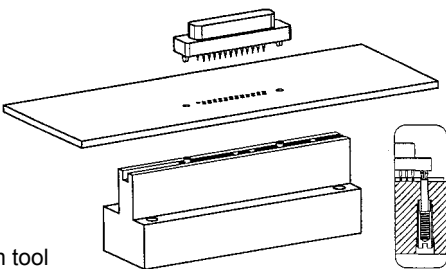
Tools – SEK, D-Sub

Identification	Part number	
<p>Top tool for SEK</p> <p>Bottom tool universal, for SEK narrow, for SEK</p> <p>Base plate for SEK, D-Sub</p>	<p>09 99 000 0197</p> <p>09 99 000 0185 09 99 000 0256</p> <p>09 99 000 0255</p>	 <p>Top tool</p> <p>Bottom tool</p> <p>Base plate</p>
<p>Bottom tool narrow for D-Sub</p> <p>Only one tool for all polarities, with or without grounding pins</p> <p>9-37 way 50 way</p>	<p>09 99 000 0600 09 99 000 0523</p>	 <p>Bottom tool</p>
<p>Plastic with metal plate insert tool for D-Sub male</p> <p>9 way 15 way 25 way</p>	<p>09 99 600 0709 09 99 600 0715 09 99 600 0725</p>	
<p>Other toolings on request</p>		

Tools – SEK, D-Sub

Identification	Part number	Drawing	Dimensions in mm
Top tool for SEK standard connectors 10 way 14 way 16 way 20 way 26 way 34 way 40 way 50 way 60 way 64 way	09 99 000 0710 09 99 000 0714 09 99 000 0716 09 99 000 0720 09 99 000 0726 09 99 000 0734 09 99 000 0740 09 99 000 0750 09 99 000 0760 09 99 000 0764		
Top tool for SEK male low-profile connectors 6 way 10 way 14 way 16 way 20 way 26 way 34 way 40 way 50 way 60 way 64 way Top tool including insert ➤ 4 Modular insert ➤ 5	09 99 000 0 06 09 99 000 0 10 09 99 000 0 14 09 99 000 0 16 09 99 000 0 20 09 99 000 0 26 09 99 000 0 34 09 99 000 0 40 09 99 000 0 50 09 99 000 0 60 09 99 000 0 64	Top tool including insert Modular insert 	
Press-out tool for complete SEK male connectors with 5.5 mm terminations	09 99 000 0220		
Support block	09 99 000 0218		

Tooling

* Further versions on request

Tools for insulation displacement termination – har-link

Identification





Part number

Crimping hand tool
for shell cable entry

27 99 000 0001

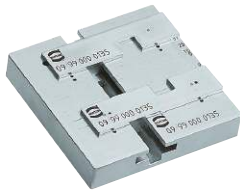

Tools for insulation displacement termination – D-Sub, SEK

Identification	Part number	Drawing	Dimensions in mm
Bench press for termination of insulation displacement connectors suitable for D-Sub SEK	09 99 000 0114		
Cabling tool for termination of flat cables suitable for D-Sub SEK female SEK DIP SEK LP, 2 rows SEK LP, 4 rows DIN 41612	09 99 000 0135 09 99 000 0115 09 99 000 0134 09 99 000 0131 09 99 000 0130 09 99 000 0150		
Insert for termination of 37-pole male D-Sub connectors	09 99 600 0201		
Hand tool with base plates (included in tool kit) for termination of insulation displacement connectors suitable for D-Sub SEK	09 99 000 0149		
Cable cutter for flat cables suitable for D-Sub SEK	09 99 000 0116		
Spare parts Blade Cutting plate	09 99 000 0179 09 99 000 0180		

Tools for FOC contacts

Identification	Part number	Drawing	Dimensions in mm
Polishing tool			
DIN 41 626	20 99 000 1092		
POF ¹⁾ cable Ø 2.2	20 99 000 1093		
Fibre stripper	20 99 000 1041 20 99 000 1045 20 99 000 1046	0.3 mm 1 mm 0.18/0.3 mm	
Crimping tool for 1 mm POF contacts – Han D®, Han E® – DIN 41 626 – Ferrule – F-SMA, -ST	20 99 000 1035		
HARTING Crimping tool for FO connector (glass fibre) SW 4.3 mm 3.8 mm 4.95 mm	20 99 000 1031		
HARTING Crimping tool for FO connector (plastic fibre) SW 6.95, 4.95 and 3.0 mm	20 99 000 1033	for crimping the strain relief to the connector ... 1031 FO cable for glass fibre ... 1033 POF ¹⁾ and SERCOS cable Ø 6.0 and 3.6	
Epoxy adhesive glass fibre	20 80 001 9902		2 ml EPO-TEK 360 with hardener (10:1), 4 g foil pack
Polishing paper for POF ¹⁾ -grain size 1000 for GI 9 µ-grain size for GI 1 µ-grain size	20 80 001 9911 20 80 001 9912 20 80 001 9913		Delivery range: Each part number ordered comprises 2 pieces

¹⁾ POF = Polymer optical fibre

Individual device connectivity tailored to device versatility.

When customized products are called for, you can always rely on HARTING.

HARTING offers a wide range of series products for data, signal and power. Most tasks are covered by a convincing solution from the standard range of board-to-board, cable-to-board or wire-to-board connectivity offered. In many instances, however, specific tasks call for the development of a connectivity solution that is tailored and attuned to specific devices. Requests range from color choices and labeling to stand-alone customer specific solutions.

We implement the connection technology and its customized integration into your devices. Our offerings include individual device connectivity and matching accessories such as cable assemblies and all the way through to complete connection boxes.



Contents

Page

From ideas to the Best Customer Solution	31.02
Production as competitive factor	31.04
Solution spectrum	31.06

CUSTOMER REQUIREMENTS

Highly qualified sales engineers record your requirements, and devise and explain initial solution approaches



DESIGN AND DEVELOPMENT

In close coordination with customers, the inventive engineers at the HARTING Technology Group develop the Best Customer Solution



PRESENTATION OF SOLUTION PROPOSALS

Presentation and discussion of the developed Device Connectivity concept



PRODUCTION

Manufacturing of products to exacting quality standards



DELIVERY

On-time delivery according to your delivery and packaging instructions





FROM IDEAS TO THE BEST CUSTOMER SOLUTION

In cooperation with your product managers and development engineers, HARTING will generate the ideal connectivity solutions for your devices.

Project management encompasses all activities required for the reliable, cost-effective and on-time handling and execution.

An initial concept is created with the help of advanced, leading edge CAD technologies and inspected in terms of feasibility in specially equipped test workshops as well as by the accredited HARTING laboratory.

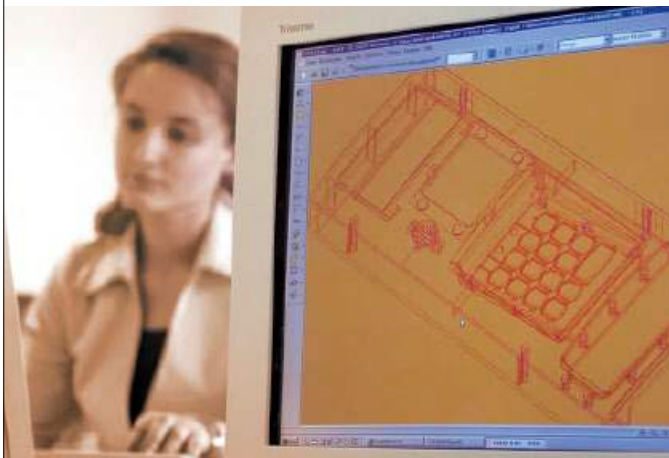

In order to attune solutions to production requirements, the tool construction, production and quality management departments contribute their expertise right from the outset.

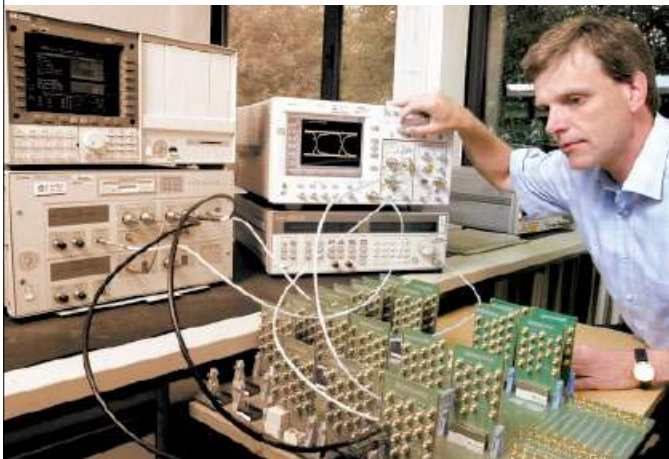

PRODUCTION OF DEVICE CONNECTIVITY:

Our products are backed by an additional, decisive competitive factor - namely the production process. HARTING production performance represents a consequent supplement to innovative product development. Divided according to technology areas, and operating with a high vertical range of manufacture, our state of the art production locations are based in Germany, England, Romania, USA and China. At HARTING, the entire range, from smallest production batches to large-scale automated production, is subject to consistent QC management.



PUNCHED AND LATHED COMPONENTS:

Punching and lathing represent basic technologies used to produce contacts. Customer requirements such as special contact materials and dimensions can be implemented directly through our own production processes.



INJECTION MOLDING:

Isolators of connectors and plastic housing are produced in an injection molding process. HARTING excels in the production of filigree isolators and the production of miniature precision parts.

We develop, construct and produce micro precision injection molding tools along the limits of feasibility.

ALUMINUM DIE-CASTING:

HARTING produces its Han® housings in an aluminum die-casting process. This technology forms the basis for robust metal housings for a wide range of different applications.



OVERMOLDING AND ENCAPSULATING TECHNOLOGY:

HARTING offers overmolded cables and connectors for cable-to-board connectivity with degree of protection IP65 / IP67. Corresponding tools and production equipment for overmolding and encapsulating technologies are available at all our production locations.



CABLE ASSEMBLY:

The cable assembly area produces cabling solutions with standard, hybrid or special cables.

We produce bus cables for Ethernet, Fieldbus systems as well as for special communication protocols.

We also assemble FOC cables on the basis of plastic, glass (monomode, gradient and grade index) or HCS fibers.



PCB PRODUCTION:

We support innovative device configurations with PCB modules as connectivity interfaces. The offerings include solutions ranging from simple PCB adapters through to complex multilayer backplanes.

Based on the Global Footprint principle, HARTING is able to provide the same production expertise at our companies in the USA, in England and in China.



PRODUCTION OF COMPLETE MODULES:

Our range of Device Connectivity offerings also covers the development and assembly of complete custom connection modules, with IP20 or IP65 / IP67 modules for data, signal and power applications tailored to suit the requirements of your specific devices. These connection modules combine our in-depth expertise and competencies in connection, PCB and housing technologies.

TAILORED PRODUCTS:

HARTING provides a convincing answer to each and every connectivity requirement – whether board-to-board, cable-to-board or wire-to-board applications. Our customers benefit from our capability of providing tailored solutions for all applications.



Customized connector concept

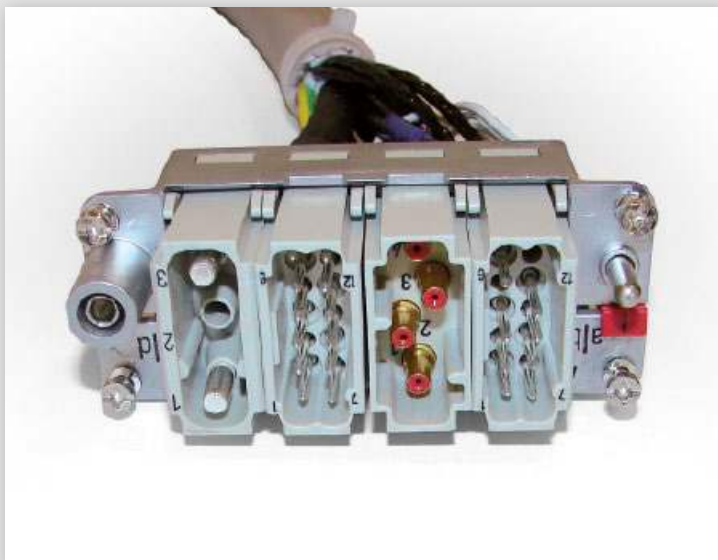

Ready-to-use pre-assembled connector with system cable

Connectivity module for installation in equipment or control cabinets

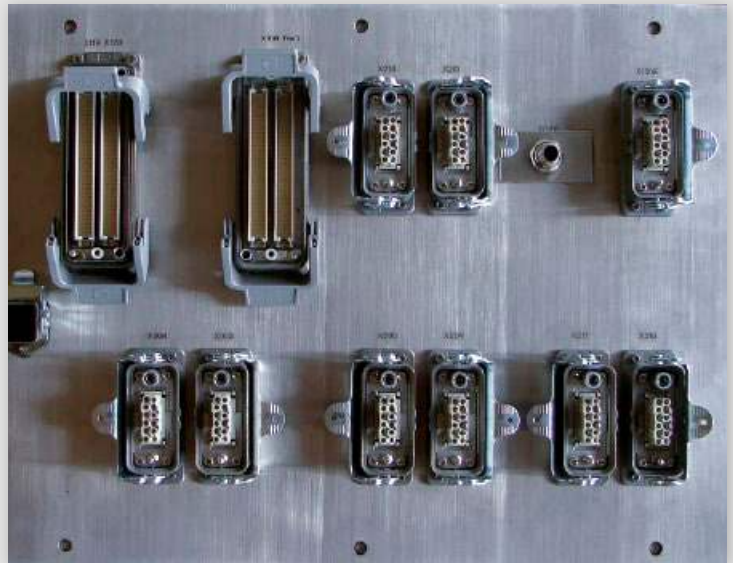

Decentralized electronic module



Decentralized electronic module with high degree of protection (IP65 / IP67)

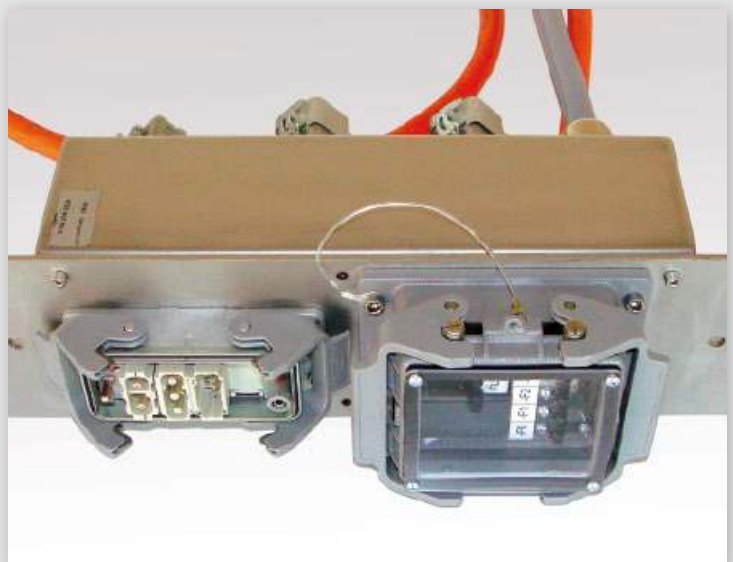



Contents

Page

Electrical engineering data	40.02
Termination technologies	40.06
IP protection levels	40.16

General

The choice of device termination technology and connectors entails more than just considering factors such as functionality, the number of contacts, current and voltage ratings. It is equally important to take account of where the connectors are to be used and the prevailing ambient conditions. This in turn means that, dependent on the conditions under which they are to be installed and pursuant to the relevant standards, different voltage and current ratings may apply for the same connectors.

The most important influencing factors and the corresponding electrical characteristics of the associated connectors are illustrated here in greater detail.

Overvoltage category

The overvoltage category is dependent on the mains voltage and the location at which the equipment is installed. It describes the maximum overvoltage resistance of a device in the event of a power supply system fault, e. g. in the event of a lightning strike.

The overvoltage category affects the dimensioning of components in that it determines the clearance air gap. Pursuant to the relevant standards, there are 4 overvoltage categories.

Extract from IEC 60 664-1, Para. 2.2.2.1.1

Equipment of overvoltage category I is equipment for connection to circuits in which measures are taken to limit transient overvoltages to an appropriately low level.

Note: Examples are protected electronic circuits.

Equipment of overvoltage category II is energy-consuming equipment to be supplied from the fixed installation.

Note: Examples of such equipment are appliances, portable tools and other household equipment with similar loads.

If such equipment is subjected to special requirements with regard to reliability and availability, overvoltage category III applies.

Equipment of overvoltage category III is equipment in fixed installations and for cases where the reliability and the availability of the equipment is subject to special requirements.

Note: Examples of such equipment are switches in the fixed installation and equipment for industrial use with permanent connection to the fixed installation.

Equipment of overvoltage category IV is for use at the origin of the installation.

Note: Examples of such equipment are electricity meters and primary overcurrent protection equipment.

Rated impulse voltages (Table 5 of DIN EN 61984)

Nominal voltage of the supply system (= rated insulation voltage of equipment)					Preferred values for the rated impulse voltage kV (1.2/50 μs)			
					Overvoltage category			
Voltage line to earth derived from the nominal voltage of the supply system to the a. c. voltage (r. m. s. value) or d. c. voltage	AC voltage (r. m. s. value)	AC voltage (r. m. s. value)	AC voltage (r. m. s. value, d. c. voltage)	AC voltage (r. m. s. value, d. c. voltage)	I Special protected levels	II Level for electrical equipment (household and others)	III Level for distribution supply systems	IV Input level
V	V	V	V	V				
100	66/115	66	60	–	0.5	0.8	1.5	2.5
150	120/208; 127/220	115; 120; 127	110; 120	220-110; 240-120	0.8	1.5	2.5	4
300	220/380; 230/400; 240/415; 260/440; 277/480	220; 230; 240; 260; 277	220	440-220	1.5	2.5	4	6
600	347/600; 380/660; 400/690; 415/720; 480/830	347; 380; 400; 415; 440; 480; 500; 577; 600	480	960-480	2.5	4	6	8
1000		660; 690; 720; 830; 1000	1000	–	4	6	8	12

Pollution degree

The dimensioning of operating equipment is dependent on environmental conditions. Any pollution or contamination may give rise to conductivity that, in combination with moisture, may affect the insulating properties of the surface on which it is deposited. The pollution degree influences the design of components in terms of the creepage distance.

The pollution degree is defined for exposed, unprotected insulation on the basis of environmental conditions.

HARTING products for the device termination (connectors) are designed as standard for Pollution Degree 3.

Pollution degree 1

in air-conditioned or clean, dry rooms, such as computer and measuring instrument rooms, for example.

Pollution degree 2

in residential, sales and other business premises, precision engineering workshops, laboratories, testing bays, rooms used for medical purposes. As a result of occasional moisture condensation, it is to be anticipated that pollution/contamination may be temporarily conductive.

Pollution degree 3

in industrial, commercial and agricultural premises, unheated storage premises, workshops or boiler rooms, also for the electrical components of assembly or mounting equipment and machine tools.

Pollution degree 4

in outdoor or exterior areas such as equipment mounted on the roofs of locomotives or tramcars.

Extract from IEC 60664-1, Para. 2.5.1

Pollution degree 1: No pollution or only dry, non-conductive pollution occurs. The pollution has no influence.

Pollution degree 2: Only non-conductive pollution occurs except that occasionally a temporary conductivity caused by condensation is to be expected.

Pollution degree 3: Conductive pollution occurs or dry non-conductive pollution occurs which becomes conductive due to condensation which is to be expected.

Pollution degree 4: The pollution generates persistent conductivity caused by conductive dust or by rain or snow.

Special ruling for connectors

Subject to compliance with certain preconditions, the standard for device termination connectors permits a lower pollution degree than that which applies to the installation as a whole. This means that in a pollution degree 3 environment, connectors may be used which are electrically rated for pollution degree 2. The basis for this is contained in DIN EN 61984, Para. 6.19.2.2.

Extract form DIN EN 61984, Para. 6.19.2.2

For a connector with a degree of protection IP54 or higher according to IEC 60529 the insulating parts inside the enclosure may be dimensioned for a lower pollution degree.

This also applies to mated connectors where enclosure is ensured by the connector housing and which may only be disengaged for test and maintenance purposes.

The conditions fulfills,

- a connector which is protected to at least IP54 as per IEC 60529,
- a connector which is installed in a housing and which as described in the standard is disconnected for testing and maintenance purposes only,
- a connector which is installed in a housing and which when disconnected is protected by a cap or cover to at least IP54,
- a connector located inside a switching cabinet to at least IP54.

These conditions do not extend to connectors which when disconnected remain exposed to the industrial atmosphere for an indefinite period.

It should be noted that pollution can affect a connector from the inside of an installation outwards.

Typical applications in which to choose pollution degree 2 connectors:

- A connector serving a drive motor which is disconnected only for the purpose of replacing a defective motor, even when the plant or system otherwise calls for pollution degree 3.
- Connectors serving a machine of modular design which are disconnected for transport purposes only and enable rapid erection and reliable commissioning. In transit, protective covers or adequate packing must be provided to ensure that the connectors are not affected by pollution/contamination.
- Connectors located inside a switching cabinet to IP54. In such cases, it is even possible to dispense with the IP54 housings of the connectors themselves.

Specifying electrical data

Electrical data for connectors are specified as per DIN EN 61984.

This example identifies a connector suitable for use in an unearthed power system or earthed delta circuit (see page 40.02, Table 5 of DIN EN 61984):

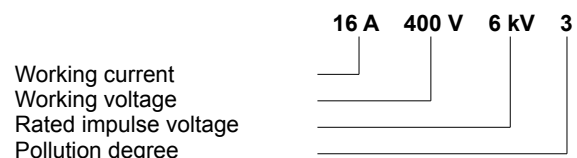

This example identifies a connector suitable exclusively for use in earthed power systems (see page 40.02, Table 5 of DIN EN 61984):

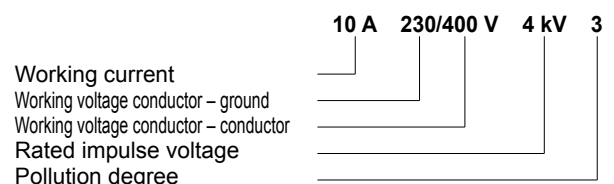

Other terms explained

Clearance air gap

The shortest distance through the air between two conductive elements (see IEC 60664-1, Para. 1.3.3). The air gaps are determined by the surge voltage withstand level.

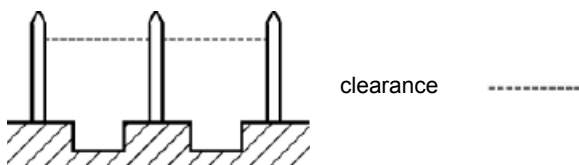

Creepage distance

Shortest distance on the surface of an insulating material between two conductive elements (see IEC 60664-1, Para. 1.3.3). The creepage distances are dependent on the rated voltage, the pollution degree and the characteristics of the insulating material.

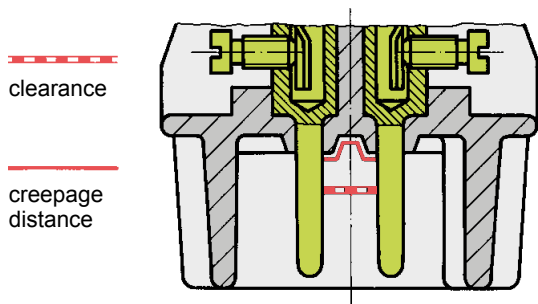
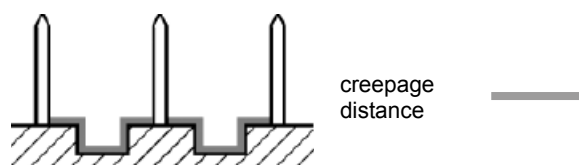

Working voltage

Fixed voltage value on which operating and performance data are based. More than one value for rated voltage or rated voltage range may be specified for the same connector.

Rated impulse voltage

The rated impulse voltage is determined on the basis of the overvoltage category and the nominal power supply voltage. This level in turn directly determines the test voltage for testing the overvoltage resistance of the connector (*Waveform voltage in 1.2/50 μs as per IEC 60060-1*).

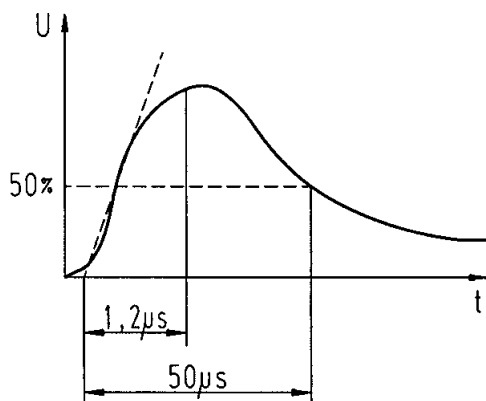

Working current

Fixed current, preferably at an ambient temperature of 40 °C, which the connector can carry on a permanent basis (without interruption), passing simultaneously through all contacts which are in turn connected to the largest possible conductors, without exceeding the upper temperature limit.

The dependence of the rated current on ambient temperature is illustrated in the respective derating diagrams.

Transient overvoltages

Short-term overvoltage lasting a few milliseconds or less, oscillatory or non-oscillatory, generally heavily damped (see IEC 60664-1, Para. 1.3.7.2). An overvoltage may occur as a result of switching activities, a defect or lightning surge, or may be intentionally created as a necessary function of the equipment or component.

Power-frequency withstand voltage

A power-frequency overvoltage (50/60 Hz).

Applied for a duration of one minute when testing dielectric strength.

For test voltages in association with surge voltage withstand levels, see extract from Table 8, DIN EN 61984.

Test voltages (Extract from Table 8, DIN EN 61984)

Impulse withstand voltage kV (1.2/50 μs)	RMS withstand voltage kV (50/60 Hz)
0.5	0.37
0.8	0.50
1.5	0.84
2.5	1.39
4	2.21
6	3.31
8	4.26
12	6.6

CTI (Comparative Tracking Index)

This figure gives an indication of the conductivity of insulating materials and affects the specified creepage distances. The influence of the CTI value on the creepage distance is as follows: the higher the index value, the shorter the creepage distance. The CTI is used to divide plastics into insulation groups.

Breakdown of insulation groups:

I	600 ≤ CTI
II	400 ≤ CTI < 600
IIIa	175 ≤ CTI < 400
IIIb	100 ≤ CTI < 175

Protection levels as per IEC 60529

The protection level describes the leak-proof character of housing, e. g. for electrical equipment. It ranges from IP00 to IP68. HARTING heavy duty Han connectors feature a standard protection level of IP65 (see page 40.16, table based on DIN VDE 0470, DIN EN 60529, IEC 60529).

Derating diagram as per DIN IEC 60512

These diagrams are used to illustrate the maximum current carrying capacity of components. The illustration follows a curve which shows the current in relation to ambient temperature. Current carrying capacity is limited by the thermal characteristics of contacts and insulating elements which have an upper temperature limit which should not be exceeded.

Current carrying capacity

The current carrying capacity is determined in tests which are conducted on the basis of the DIN IEC 60 512 part 5. The current carrying capacity is limited by the thermal properties of materials which are used for inserts as well as by the insulating materials. These components have a limiting temperature which should not be exceeded.

The relationship between the current, the temperature rise (loss at the contact resistance) and the ambient temperature of the connector is represented by a curve. On a linear co-ordinate system the current lies on the vertical line (ordinate) and the ambient temperature on the horizontal line (abscissa) which ends at the upper limiting temperature.

In another measurement the self-heating (Δt) at different currents is determined.

At least 3 points are determined which are connected to a parabolic curve, the basic curve.

The corrected current carrying capacity curve is derived from this basic curve. The reasons for the correction are external factors that bring an additional limitation to the current carrying capacity, i.e. connectable wire gauge or an unequal dispersion of current.

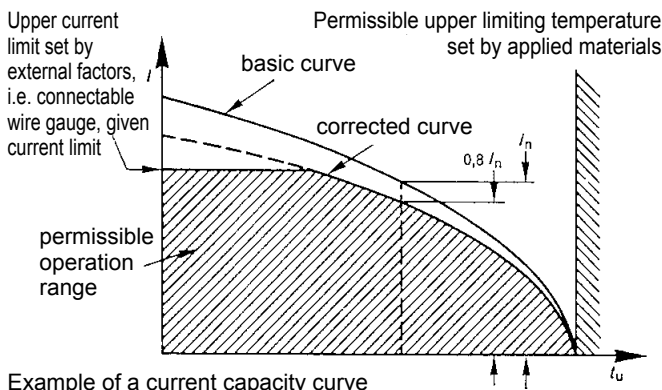

Example of a current capacity curve

Definition: The rated current is the continuous, not interrupted current a connector can take when simultaneous power on all contacts is given, without exceeding the maximum temperature.

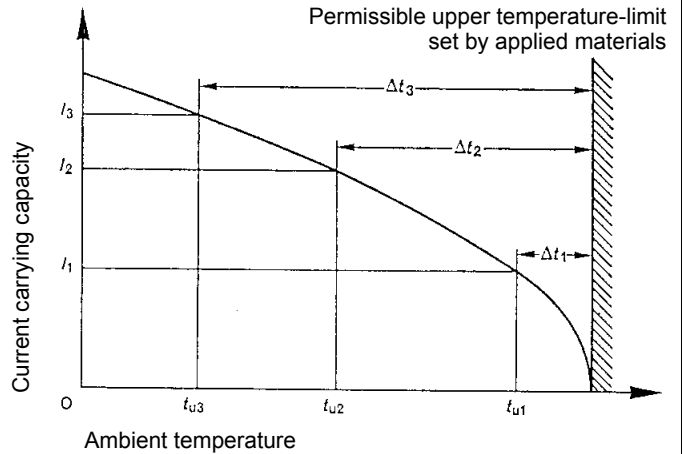

Example of a current carrying curve

Acc. to IEC 61984 the sum of ambient temperature and the temperature rise of a connector shall not exceed the upper limiting temperature. The limiting temperature is valid for a complete connector, that means insert plus housing.

As a result the insert gives the limit for the temperature of a complete connector and thus housings as well.

In practice it is not usual to load all terminals simultaneously with the maximum current. In such a case one contact can be loaded with a higher current as permitted by the current capacity curve, if less than 20 % of the whole is loaded.

However, for these cases there are no universal rules. The limits have to be determined individually from case to case. It is recommended to proceed in accordance with the relevant rules of the DIN IEC 60 512 part 5.

Current carrying capacity of copper wires

Diameter [mm ²] of single wires in a three-phase system	0.75	1	1.5	2.5	4	6	10	16	25	35
Type of installation										
B1 Wires in protective tubes and installation conduits	7.6	10.4	13.5	18.3	25	32	44	60	77	97
B2 Cables and wires in protective tubes and installation conduits	–	9.6	12	16.5	23	29	40	53	67	83
C Cables and wires at walls	–	11.7	15.2	21	28	36	50	66	84	104
D Cables and wires on a bed	–	11.5	16.1	22	30	37	52	70	88	114

Depiction in accordance with DIN EN 60 204 for PVC-insulated copper wires in an ambient temperature of + 40 °C under permanent operating conditions. For different conditions and temperatures, installations, insulation materials or conductors the relevant corrections have to be carried out.

Solder pins for printed circuit boards

Solder pins for reflow soldering

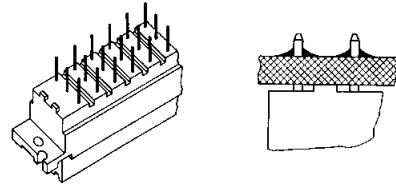

Solder lugs for discrete wiring

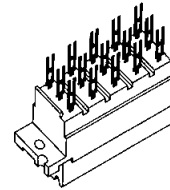

Press-in technology for printed circuit boards

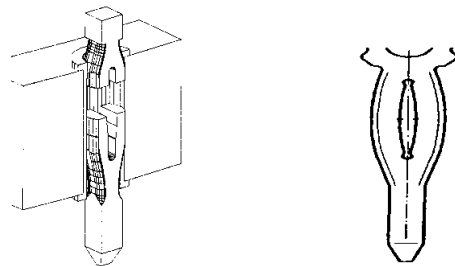

Crimp contacts for flexible wiring, selective loading and ease of replacement

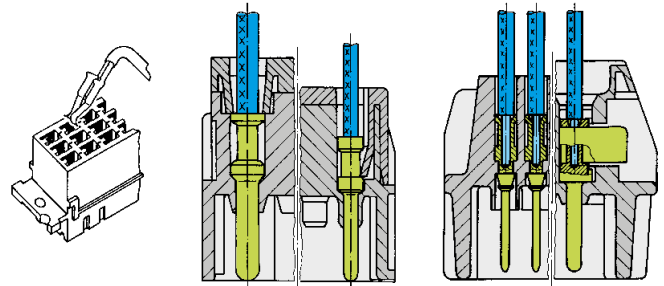

Insulation displacement contacts for mass termination of flat cable or round cable

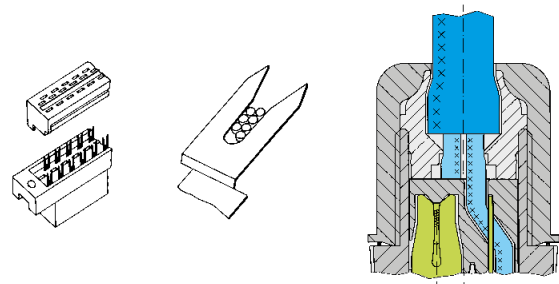

Faston blades for higher power discrete wiring

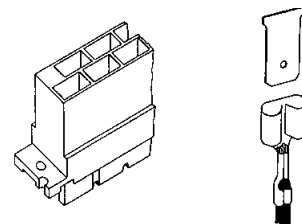

Screw terminal

Screw terminals meet VDE 0609 / EN 60 999. Dimensions and tightening torques for testing are shown opposite.

The relevant regulations state that in the case of

- Terminals with wire protection.
– the use of ferrules is not necessary

Axial screw terminal

This termination associates the benefits of screw and crimp terminals.

- Less space required
- Easy handling
- No special tools

The axial screw termination is suitable for fine strands wires.

Cage-clamp terminal

This termination method requires very little preparation of the wire and no special tools, leading to a low installed cost and a high degree of mechanical security.

- For all stranded and solid wires with a cross section 0.14 to 2.5 mm².
- Ease of termination. Conductor and screwdriver are in same plane.
- No special preparation of stripped conductor.
- The larger the conductor the higher the clamping force.
- The termination is vibration-proof.
- Guaranteed constant low resistance connection of the cage-clamp terminal.
- The cage-clamp system is internationally approved. VDE, SEV, CSA, UL, ÖVE, SEMKO, LCIE (France), Germanischer Lloyd, DET Norske Veritas

Solder connection

The term "soldering" is defined in DIN 8505:

"Soldering is a method of connecting metallic materials using an additional melting metal, if necessary with the assistance of a flux and/or protective gas. The melting temperature of the solder must lie beneath the minimum melting temperature of the base metals being connected. These base metals shall be tinned without melting themselves."

Soft solders commonly used on electronic equipment are to DIN 1707-100. Today's lead free solders have a melting range between 217 °C and 227 °C depending on the composition of the alloy. For soldering metallic materials the flux is defined in DIN EN 29454-1. Tests are explained in DIN 8526.

Screw dimensions and tightening torque for screw terminals

Wire gauge (mm ²)	1.5	2.5	4	6	10	16
Screw thread	M 3	M 3	M 3.5	M 4	M 4	M 6
Test moment of torque (Nm)	0.5	0.5	0.8	1.2	1.2	1.2*
min. pull-out for stranded wire (N)	40	50	60	80	90	100

* for screws without heads (Han® K 4/8)

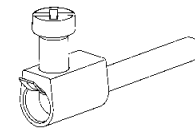

with wire protection

Remarks on the axial screw technique

The wire gauges mentioned in the catalogue refer to geometric wire gauges of cables.

Background:

According to DIN VDE 0295 for cables and insulated wires the wire gauge will be determined by conductance (Ω/km) and maximum wire diameter. A minimum cable diameter is not specified! (Example: nominal wire gauge 95 mm² → real, geometric wire gauge 89 mm²)

Recommendation:

The use of cables with extreme geometric wire gauge deviation should be checked separately with the use of the axial screw termination.

One conductor per termination

Slot for screwdriver

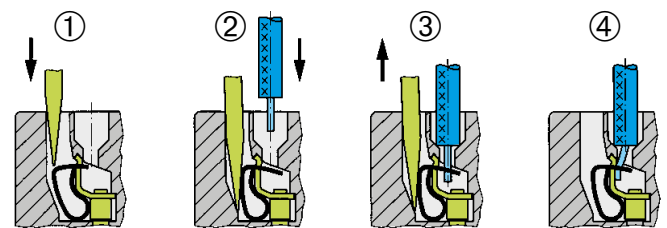
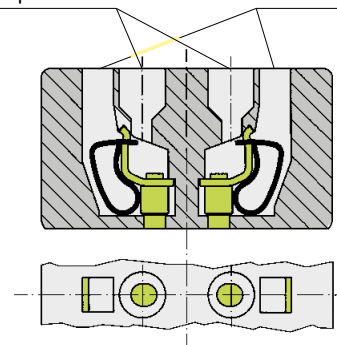

Screwdriver width: 3.0 x 0.5 mm

Solderless termination for connectors has proven to be reliable for decades. Today the use of press-in connectors encompasses all fields of electrical and electronical applications.

Pressing of electrical components, mainly connectors, is characterised through the matching of the connector pin and the plated through hole of the pcb. Whereas the desired electrical characteristics can be attained relatively independant from the design of the press-in zone, the mechanical characteristics of the press-in zone are crucial for the reliable assembly of connectors where pcb's have different surfaces.

Although the scope of requirements at the press-in process is generally defined in time-tested specifications, the novel press-in zones should offer an optimal handling and a reliable termination. Essentially, this is guaranteed through the design of the press-in zone and the meticulous observance of tolerances. HARTING has been using FEM simulations for the calculation and optimisation of press-in zones for a long period of time. This expertise allows us to simulate various pcb configurations very accurate.

Due to the high deformation resistance and resilience of **har:press** contacts, they can be easily and repeatedly removed in case of repairs without impairment to their functioning.

har:press is extremely versatile and offers a reliable electrical contact, therefore it is especially well suited for applications with these surfaces.

Please contact us for detailed test reports.

Benefits of the press-in technology

- Thermal shocks associated with the soldering process and the risk of the board malfunction are avoided.
- No need for the subsequent cleaning of the assembled pcb's
- Additional wrap connections are made possible by using connectors with long pins
- Unlimited and efficient processing of partially gold-plated pins for rear I/O - manual soldering is no longer necessary!

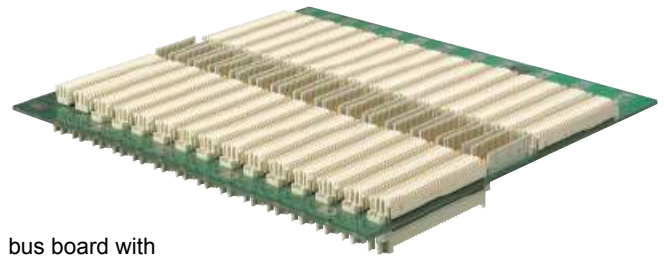

bus board with press-in connectors

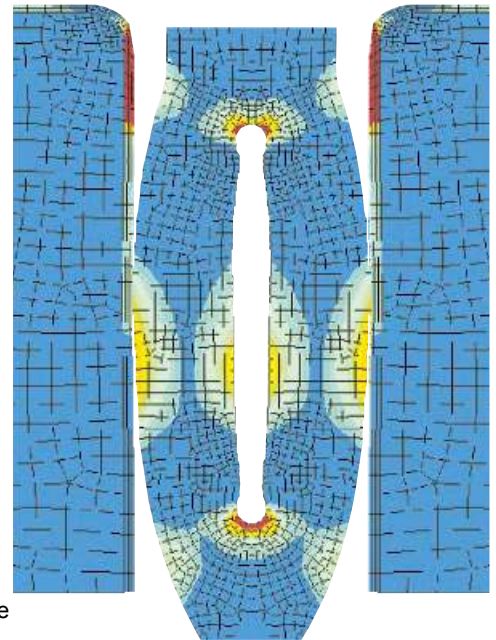

FEM simulation of the needle eye press-in zone

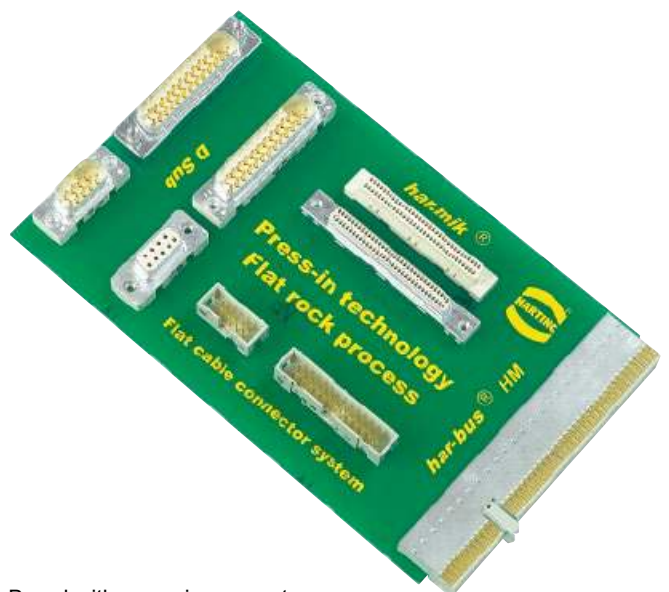

Board with press-in connectors

The processing of press-in connectors can be divided into 3 phases, containing both mechanical and metallurgical operations:

1. Centering and placing of the termination pins

The centering of connectors before pressing is important in order to prevent damage to the pcb and the termination pins. Centering can be omitted when connectors are pressed using a flat rock die.

HARTING offers insert blocks for male connectors to make the centering of connectors unnecessary.

2. Pressing in the pins

In the press-in process the insertion force is continuously transformed into compression force. The resulting friction frees the contacting bars of insulating films. Superfluous plating (tin) is transferred within the plated through hole. A gas-tight connection of fresh non-oxidised metal surfaces is obtained.

3. Obtaining the final position

The press-in operation should be terminated as soon as the connector obtains its final position on the pcb to avoid unnecessary compressive stress. The press-in machines of HARTING feature automatic termination of the press-in operation independent of pcb thickness and surface properties.

The entire dynamic press-in process is characterised through changes of the press-in force that can be statistically evaluated. HARTING records the changes of force with the help of special software. This is an important step towards permanent process control and documented manufacturing data.

The **har:press**-zone is based on the industry renowned needle eye technology. Its special design allows for compensation of tolerances of pcb surface properties (eg. superfluous tin plating). The excessive material is displaced within the plated through hole, whereby a gas-tight and corrosion resistant electrical connection is assured.

Phase 1

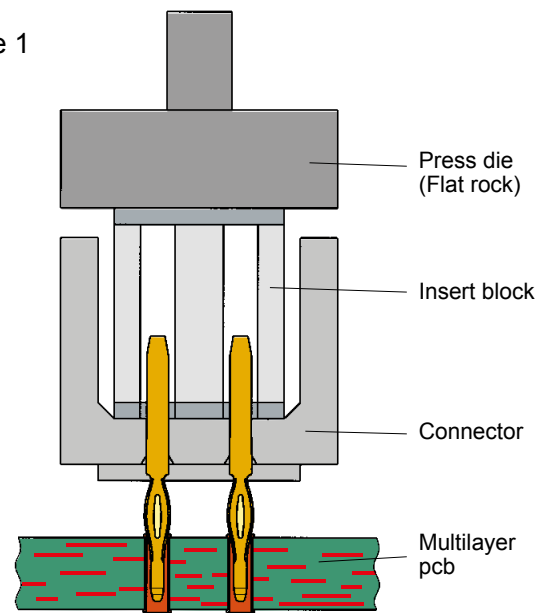

Phase 2

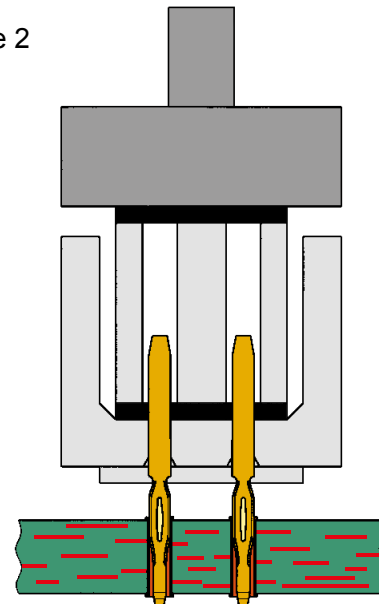

Phase 3

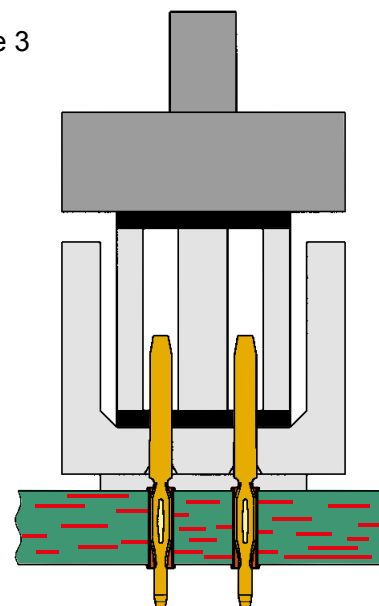

Recommended configuration of plated through holes

In addition to the hot-air-level (HAL) other pcb surfaces are getting more important. Due to their different properties, such as mechanical strength and coefficient of friction we recommend the following configuration of pcb through holes.

<i>Tin-lead plated PCB (HAL) acc. EN 60 352-5</i>	Hole-Ø	1.15 \pm 0.025 mm
	Cu	min. 25 μ m
	Sn	max. 15 μ m
	Plated hole-Ø	0.94-1.09 mm

<i>Chemical tin-plated PCB</i>	Hole-Ø	1.15 \pm 0.025 mm
	Cu	min. 25 μ m
	Sn	min. 0.8 μ m
	Plated hole-Ø	1.00-1.10 mm

<i>Au / Ni plated PCB</i>	Hole-Ø	1.15 \pm 0.025 mm
	Cu	min. 25 μ m
	Ni	3-7 μ m
	Au	0.05-0.12 μ m
	Plated hole-Ø	1.00-1.10 mm

<i>Silver plated PCB</i>	Hole-Ø	1.15 \pm 0.025 mm
	Cu	min. 25 μ m
	Ag	0.1-0.3 μ m
	Plated hole-Ø	1.00-1.10 mm

<i>OSP copper plated PCB</i>	Hole-Ø	1.15 \pm 0.025 mm
	Cu	min. 25 μ m
	Plated hole-Ø	1.00-1.10 mm

PCB board thickness: ≥ 1.6 mm

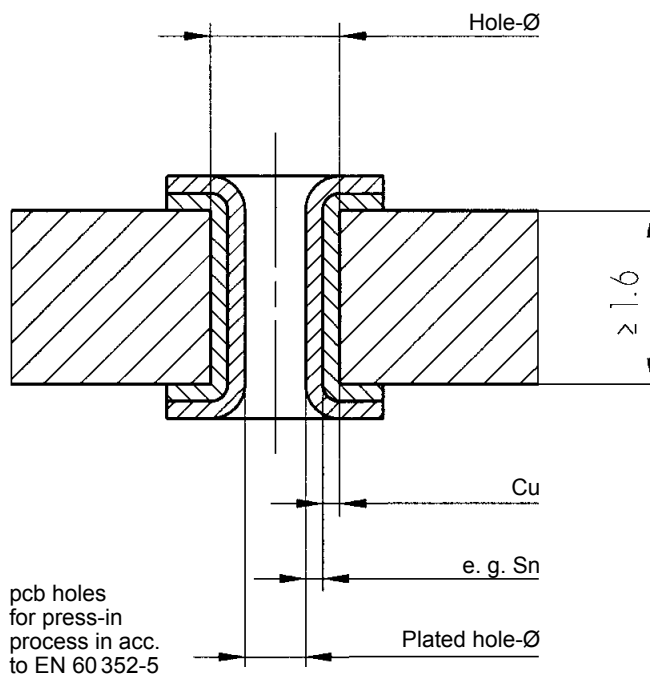
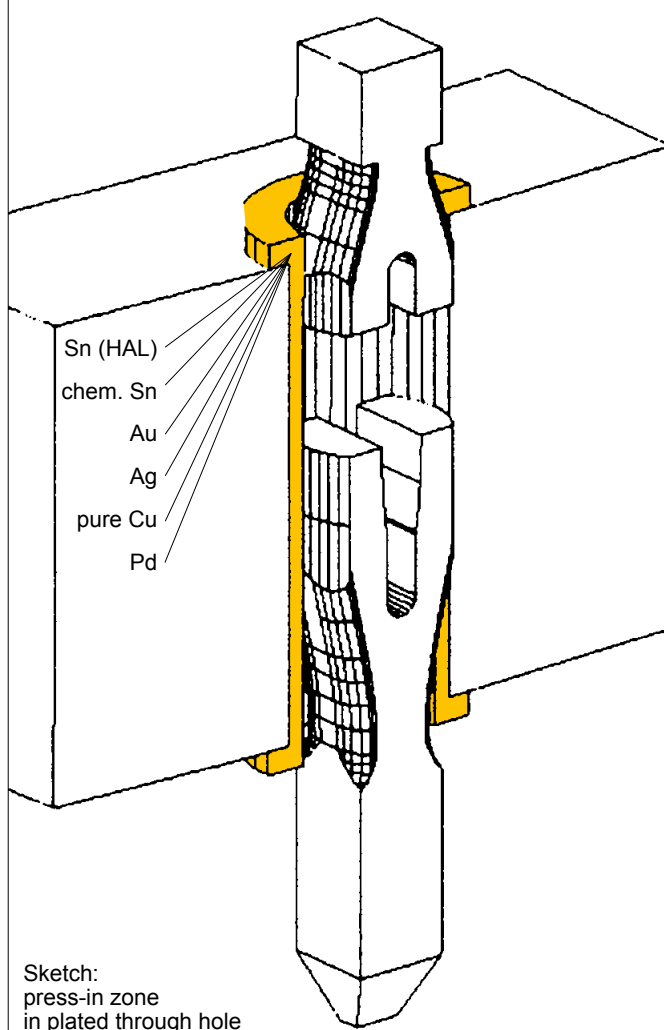

Quality control of the press-in termination

The press-in force correlates with the diameter of the plated through hole and with the friction coefficient of the surface; therefore it can be used for a continuous monitoring of the process.

The retention force, as an indirect measure of the normal force, serves to qualify the process or random tests

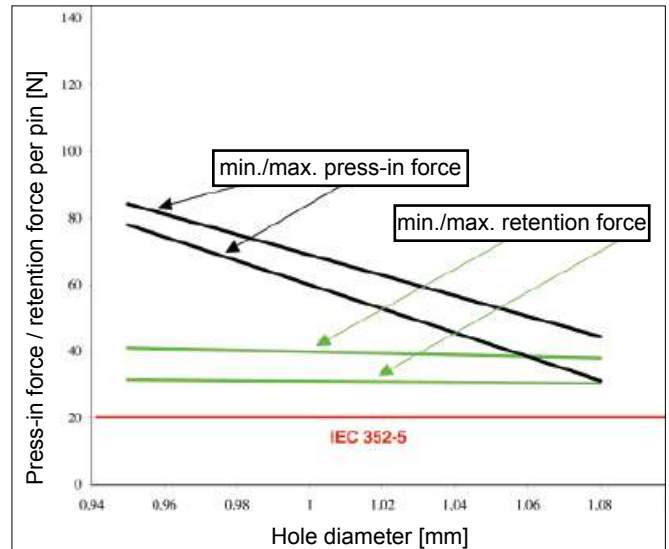

Typical press-in and retention forces for the D-Sub press-in zone

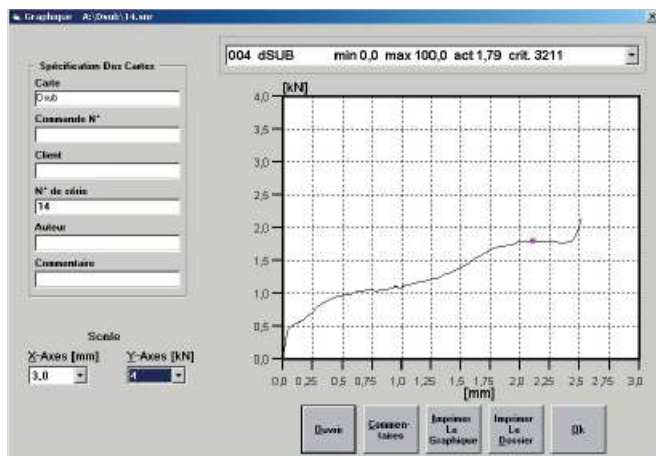

The automatic press-in machines of HARTING feature a graphical user interface for monitoring the process and the quality of the press-in termination (see chapter 20).

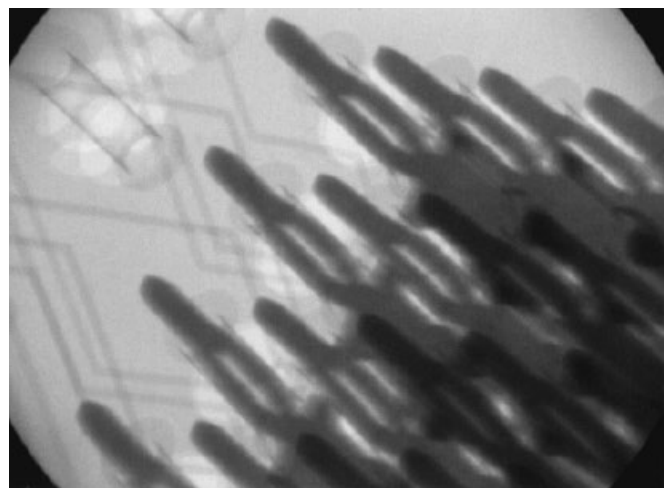

X-ray photo of a pressed-in connector

HARTING assists you with the most advanced quality assurance methods beyond the usual scope.

The continuing trend towards miniaturisation has revolutionised the assembly of electronic components. For the past 15 years, most components have been secured directly to the pcb surface by means of Surface Mount Technology (SMT). By dispensing with drilled holes on the pcb, a space saving of up to 70 percent is achieved.

Today, typical components such as resistors, ICs, capacitors, and connectors with straight terminal pins are almost exclusively fitted using SMD (Surface Mount Device) technology in mass production. In contrast, angled SMD connectors at the edge of the board have not been successful because of tolerance problems (co-planarity) and stresses during mating. Modified solder connectors for assembly with „Pin in Hole Intrusive Reflow“ process offer a better solution. These can be mounted at low cost, utilising existing SMD production lines.

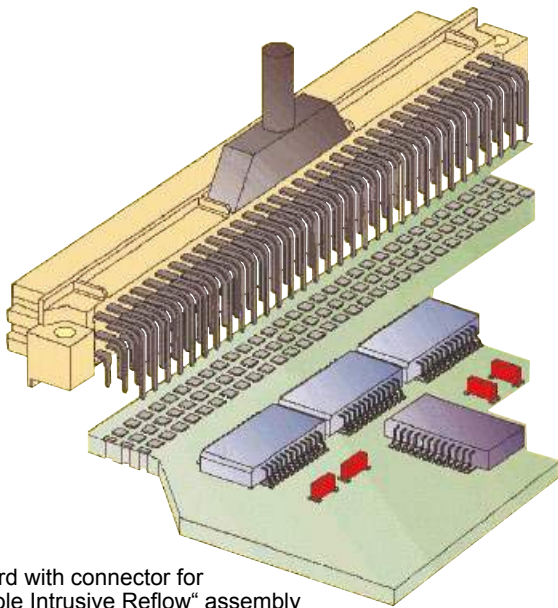

SMT board with connector for „Pin in Hole Intrusive Reflow“ assembly

„Pin in Hole Intrusive Reflow“

In this process, the connector is inserted into plated through holes in a comparable way to conventional component mounting. All other components can be assembled on the pcb surface.

The components are positioned using pick-and-place machines. These automatic assembly machines differ according to whether the components are small, lightweight or bulky. Connectors are considered bulky (odd form) because of their comparatively heavy

weight and large volume which makes them more difficult to grip. Furthermore, machines for odd form components must have higher insertion power to fit the components into pcb holes, which are filled with solder paste. As a rule, modern SMC production lines are equipped with both types of machine, therefore the „Pin in Hole Intrusive Reflow“ process generally entails no extra investment costs for the user.

Conventional assembly process:

1. Application of solder paste
2. Positioning the components
3. Positioning odd form components
4. Reflow soldering
5. Pressing in or partially dip soldering the connector at the board edge
6. Quality inspection

„Pin in Hole Intrusive Reflow“ assembly:

1. Application of solder paste
2. Positioning the components
3. Positioning odd form components
4. Reflow soldering
- ~~5. Pressing in or partially dip soldering the connector at the board edge~~
6. Quality inspection

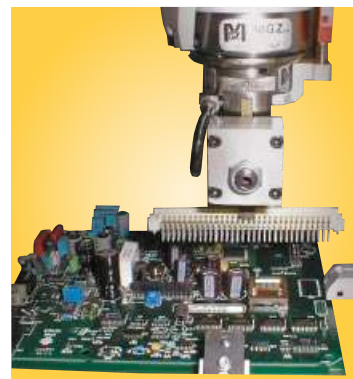

Pick-and-place machine for odd form components (Courtesy of JOT Automation GmbH)

Application of solder paste

Before the components are assembled, solder paste must be applied to all the solder pads (for connecting surface-mount components) and the plated through contacts (pcb holes for „Pin in Hole Intrusive Reflow“ insertion). Usually a screen printing process is used for this purpose. A squeegee moves across the pcb, which is masked with screens and presses the solder paste into all unmasked areas. To ensure that the plated through holes are completely filled, significantly more solder paste must be applied than traditional solder pads on the pcb surface. The required quantity can be set exactly via several parameters.

As an alternative to screen printing, the solder paste can be applied by means of a dispenser. A high-precision robot moves the dispenser to all required positions on the pcb. The dispensing method is particularly suitable for small pcb's or applications which demand high precision and flexibility in dispensing volumes.

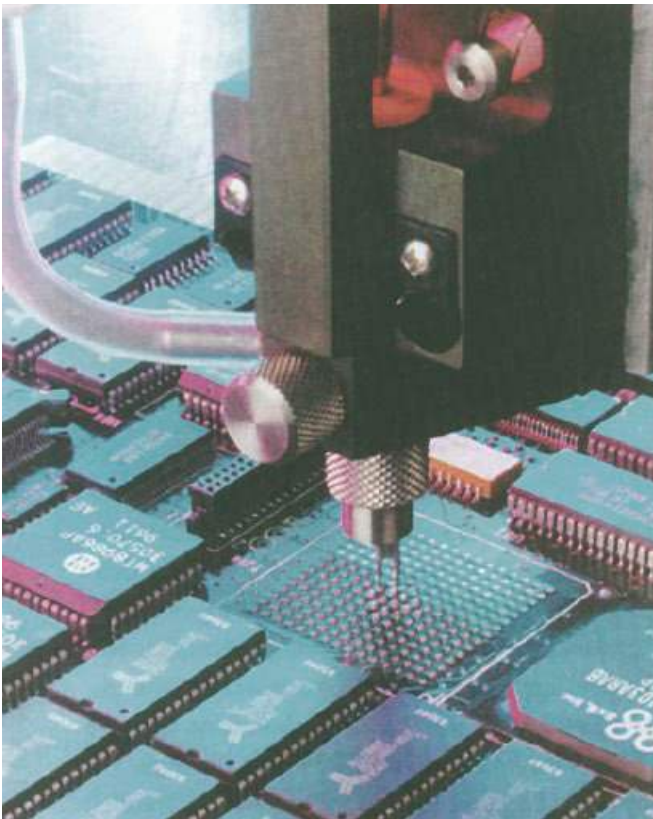

Dispenser in operation

Requirements for the solder connection

There are numerous scientific studies dealing with calculation of the required quantity of solder paste. These studies use various parameters, e.g. the shrinking factor of the paste during soldering or the thickness of the screens used for masking the pcb. Since such calculation methods are complicated to apply, the following rule of thumb has proved valuable in practice:

$$V_{\text{Paste}} = 2(V_H - V_P)$$

in which:

V_{Paste} = Required volume of solder paste

V_H = Volume of the plated through hole

V_P = Volume of the connector termination in the hole

Comment: the multiplier „2“ compensates for solder paste shrinkage during soldering. For this purpose, it was assumed that 50 % of the paste consists of the actual solder, the other 50 % being soldering aids.

At the beginning of a new production batch, the process parameters, such as quantity of solder paste and soldering temperature, can be set by interpreting simple cross-sections of the soldered connection. A reliable measure for achieving optimum parameters is the quantity of solder required to fill the hole. In soldered connections of high quality, the holes are filled to between 75 % and 100 %.

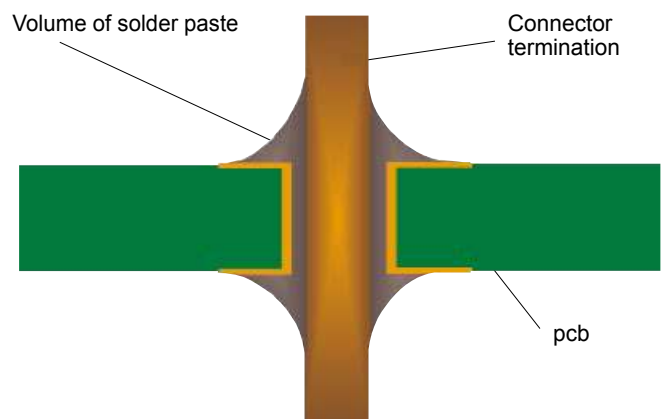

Plated through hole with connector termination

SMC connectors

SMC (Surface Mount Compatible) connectors have to withstand temperatures of up to 225°C in the reflow oven for 10 to 15 seconds. Therefore, the moulding must be made from a dimensionally stable plastic which expands at the same rate as the pcb material when subjected to heat.

The length of the connector contacts should be such that they protrude by no more than 1.5 millimetres after insertion to the pcb. Each contact collects solder on its tip as it penetrates the solder paste in the hole. So if the contact was too long, this solder would no longer be able to reflow back into the plated through hole by capillary action during the soldering process, therefore the quality of the soldered connection would suffer as a result.

Connector design must permit both automatic assembly with pick-and-place machines and manual positioning for test and pre-production batches. It is also important for the packaging of the connectors to be suitable for automated assembly. Experience shows that deep-drawn film and reel packaging fed into the pick-and-place machines with the aid of a conveyor system is particularly suitable.

Advantages for using SMC connectors are:

- Partial dip soldering or press-in is no longer required
- High mechanical stability
- Complete compatibility with Surface Mount Technology
- Savings through integration into the automated assembly process
- Reduced floor space in the production plant



HARTING connector mounted in a tape ready for automatic placement.

HARTING SMC technology

HARTING offers its customers a complete system concept for integrating SMC technology into existing production lines. We manufacture a wide range of SMC connectors (3 and 5 row) in compliance with IEC 60603-2 and D-Sub connectors in compliance with IEC 60807. In addition, HARTING supports the market with packaging and processing concepts, which have been developed in collaboration with renowned manufacturers of SMC soldering and assembly plants.

Advantages of the „Pin in Hole Intrusive Reflow“ process:

- Partial dip soldering or press fitting is no longer required
- Complete compatibility with Surface Mount Technology
- Complete integration into the automated assembly process
- Reduced floor space in the production plant
- As a rule, no additional investment costs

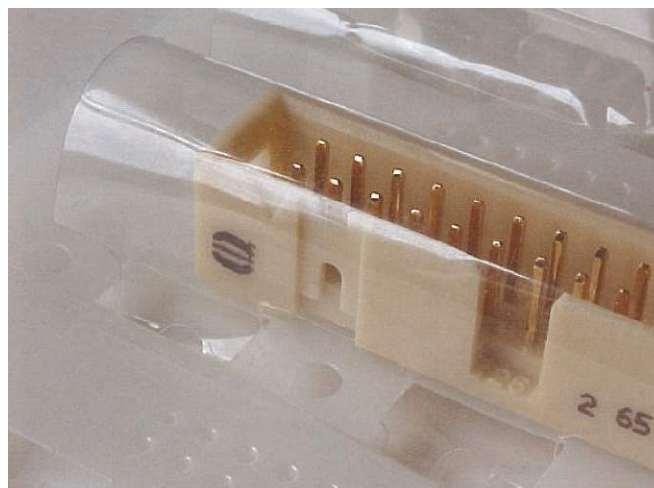

HARTING connector mounted in a tape ready for placement using an odd form assembly station.

Crimp connection

A perfect crimp connection is gastight, therefore corrosion free and amounts to a cold weld of the parts being connected. For this reason, major features in achieving high quality crimp connections are the design of the contact crimping parts and of course the crimping tool itself. Wires to be connected must be carefully matched with the correct size of crimp contacts. If these basic requirements are met, users will be assured of highly reliable connections with low contact resistance and high resistance to corrosive attack.

The economic and technical advantages are:

- Constant contact resistance as a result of precisely repeated crimp connection quality
- Corrosion free connections as a result of cold weld action
- Pre-preparation of cable forms with crimp contacts fitted
- Optimum cost cable connection

Requirements for crimp connectors are laid down in DIN IEC 60352-2, Amend. 2, as illustrated in the table.

Pull out force of stranded wire

The main criterion by which to judge the quality of a crimp connection is the retention force achieved by the wire conductor in the terminal section of the contact. DIN IEC 60352, part 2, defines the extraction force in relation to the cross-section of the conductor.

When fitted using HARTING crimping tools and subject to their utilization in an approved manner, our crimp connectors comply with the required extraction forces.

Crimping tools

Crimping tools (hand operated or automatic) are carefully designed to produce with high pressure forming parts a symmetrical connection of the crimping part of the contact and the wire being connected with the minimum increase in size at the connection point. The positioner automatically locates the crimp and wire at the correct point in the tool.

A ratchet in the tool performs 2 functions:

It prevents insertion of the crimp into the tool for crimping before the jaws are fully open

It prevents the tool being opened before the crimping action is completed

Identical, perfectly formed, connections can be produced using this crimping system.

Crimp-cross section

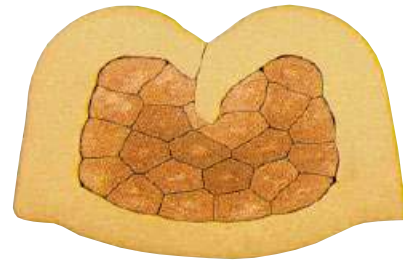

B shape cross section stamped contact

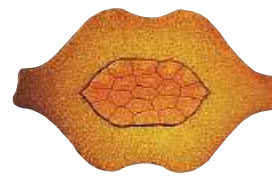

H shape cross section turned contact

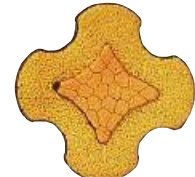

4 points shape cross section turned contact

Tensile strength of crimped connections

Conductor cross-section		Tensile strength
mm ²	AWG	N
0.05	30	6
0.08	28	11
0.12	26	15
0.14		18
0.22	24	28
0.25		32
0.32	22	40
0.5	20	60
0.75		85
0.82	18	90
1.0		108
1.3	16	135
1.5		150
2.1	14	200
2.5		230
3.3	12	275
4.0		310
5.3	10	355
6.0		360
8.4	8	370
10.0		380

Extract from DIN IEC 60352-2, Amend. 2, Table IV

The connector's housing, sealing and locking mechanism protect the connection from external influences such as mechanical shocks, foreign bodies, humidity, dust, water or other fluids such as cleansing and cooling agents, oils, etc. The degree of protection the housing offers is explained in the IEC 60 529, DIN EN 60 529, standards that categorize enclosures according to foreign body and water protection.

The following table shows the different degrees of protection.

Code letters (International Protection)		First Index Figure (Foreign bodies protection)		Second Index Figure (Water protection)	
IP		6		5	
Index figure	Degree of protection		Index figure	Degree of protection	
0	No protection		0	No protection against water	No protection against water
1	Protection against large foreign bodies		1	Drip-proof	Protection against vertical water drips
2	Protection against medium sized foreign bodies		2	Drip-proof	Protection against water drips (up to a 15° angle)
3	Protection against small solid foreign bodies		3	Spray-proof	Protection against diagonal water drips (up to a 60° angle)
4	Protection against grain-shaped foreign bodies		4	Splash-proof	Protection against splashed water from all directions
5	Protection against injurious deposits of dust		5	Hose-proof	Protection against water (out of a nozzle) from all directions
6	Protection against ingress of dust		6	Strong hose-proof	Protection against strong water (out of a nozzle) from all directions
			7	Protected against immersion	Protected against temporary immersion
			8	Water-tight	Protected against water pressure

Please send me further information:



Interface Connectors

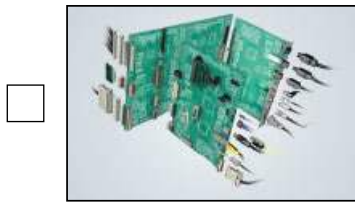

Device Connectivity



Industrial Connectors Han®



**Connectors
DIN 41612**



**Intelligent Network
Solutions**

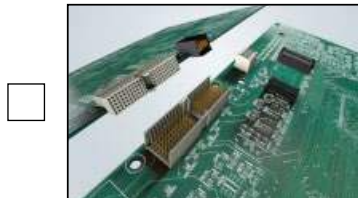

**Coaxial and Metric
Connectors**



**Application
brochure**



TCA Connectors



**High Speed
Backplanes**

Sender:

Company: _____

Street: _____

Department: _____

Postcode/Town: _____

Name: _____

Country: _____

Prenome: _____

Phone: _____

Function: _____

Fax: _____

Please send it by post or fax to your local HARTING representatives (see page addresses) or visit us under www.HARTING.com.

E-Mail: _____

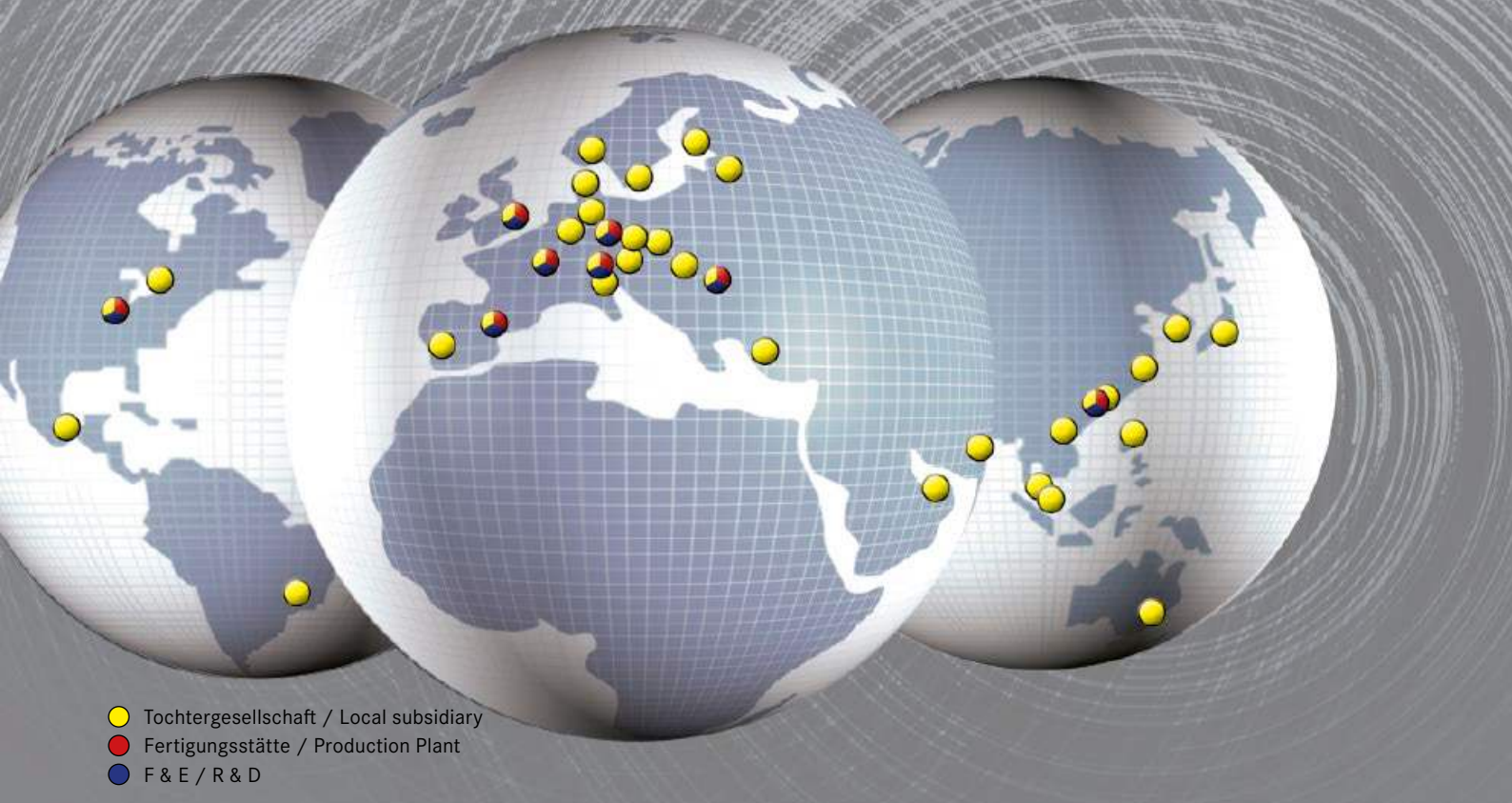

- Tochtergesellschaft / Local subsidiary
- Fertigungsstätte / Production Plant
- F & E / R & D

Sales Network – worldwide



Afghanistan

see United Arab Emirates

Albania

see Austria

Argentina

Condelectric S.A.
Hipólito Yrigoyen 2591
1640 – Martínez
Buenos Aires – Argentina
Phone +54 11 4836 1053
Fax +54 11 4836 1053
comercial@condelectric.com.ar

Armenia

see Russia

Australia

HARTING Pty Ltd
Suite 11 / 2 Enterprise Drive
Bundoora 3083, AUS-Victoria
Phone +61 3 9466 7088
Fax +61 3 9466 7099
au@HARTING.com
www.HARTING.com.au

Austria

HARTING Ges.m.b.H.
Deutschstraße 19, A-1230 Wien
Phone +431 6162121
Fax +431 6162121-21
at@HARTING.com
www.HARTING.at

Azerbaijan

see Turkey

Bahrain

see United Arab Emirates

Belarus

see Russia

Belgium

HARTING N.V./S.A.
Z.3 Doornveld 23, B-1731 Zellik
Phone +32 2 466 0190
Fax +32 2 466 7855
be@HARTING.com
www.HARTING.be

Bosnia and Herzegovina

see Austria

Brazil

HARTING Ltda.
Rua Major Paladino 128 –
Prédio 11
CEP 05307-000 – São Paulo –
SP – Brasil
Phone +55 11 5035 0073
Fax +55 11 5034 4743
br@HARTING.com
www.HARTING.com.br

Brunei

see Singapore

Bulgaria

see Austria

Canada

HARTING Canada Inc.
8455 Trans-Canada Hwy., Suite 202
St. Laurent, QC, H4S1Z1, Canada
Phone 855-659-6653
Fax 855-659-6654
info.ca@HARTING.com
www.HARTING.ca

China

HARTING (Zhuhai) Sales Ltd.
Shanghai Branch, Room 3501,
Grand Gateway I, No. 1 Hong Qiao Road
Xu Hui District, Shanghai 200030, China
Phone +86 21 6386 2200
Fax +86 21 6386 8636
cn@HARTING.com
www.HARTING.com.cn

Croatia

see Austria

Czech Republic

HARTING s.r.o.
Mlýnská 2, CZ-160 00 Praha 6
Phone +420 220 380 460
Fax +420 220 380 461
cz@HARTING.com
www.HARTING.cz

Denmark

HARTING ApS
Hjulmagervej 4a
DK – 7100 Vejle
Phone +45 70 25 00 32
Fax +45 75 80 64 99
dk@HARTING.com
www.HARTING.dk

Egypt

see United Arab Emirates

Estonia

see Finland

Finland

HARTING Oy
Teknobulevardi 3-5
FI-01530 Vantaa
Phone +358 207 291 510
Fax +358 207 291 511
fi@HARTING.com
www.HARTING.fi

France

HARTING France
181 avenue des Nations, Paris Nord 2
BP 66058 Tremblay en France
F-95972 Roissy Charles de Gaulle Cédex
Phone +33 1 4938 3400
Fax +33 1 4863 2306
fr@HARTING.com
www.HARTING.fr

Germany

HARTING Deutschland GmbH & Co. KG
P.O. Box 2451, D-32381 Minden
Simeons carré 1, D-32427 Minden
Phone +49 571 8896 0
Fax +49 571 8896 282
de@HARTING.com
www.HARTING.de

Georgia

see Russia

Great Britain

HARTING Ltd., Caswell Road
Brackmills Industrial Estate
GB-Northampton, NN4 7PW
Phone +44 1604 827 500
Fax +44 1604 706 777
gb@HARTING.com
www.HARTING.co.uk

Hong Kong

HARTING (HK) Limited
Regional Office Asia Pacific
3512 Metroplaza Tower 1
223 Hing Fong Road
Kwai Fong, N. T., Hong Kong
Phone +852 2423 7338
Fax +852 2480 4378
ap@HARTING.com
www.HARTING.com.hk

Hungary

HARTING Magyarország Kft.
Fehérvári út 89-95, H-1119 Budapest
Phone +36 1 205 34 64
Fax +36 1 205 34 65
hu@HARTING.com
www.HARTING.hu

Iceland

see Great Britain

India

HARTING India Pvt Ltd
7th Floor (West Wing), Central Square II
Unit No.B-19 Part, B 20&21
TVK Industrial Estate
Guindy, Chennai – 600032
Phone +91-44-43560415
+91-44-43456262
Fax +91-44-43560417
in@HARTING.com
www.HARTING.in

Indonesia

see Malaysia

Iran

see United Arab Emirates

Iraq

see United Arab Emirates

Israel

COMTEL
Israel Electronic Solutions Ltd.
Bet Hapamon, 20 Hataas st.
P.O.Box 66
Kefar-Saba 44425
Phone +972-9-7677240
Fax +972-9-7677243
sales@comtel.co.il
www.comtel.co.il

Italy

HARTING SpA
Via Dell' Industria 7
I-20090 Vimodrone (Milano)
Phone +39 02 250801
Fax +39 02 2650 597
it@HARTING.com
www.HARTING.it

Japan

HARTING K. K.
Yusen Shin-Yokohama 1 Chome Bldg., 2F
1-7-9, Shin-Yokohama, Kohoku
Yokohama 222-0033 Japan
Phone +81 45 476 3456
Fax +81 45 476 3466
jp@HARTING.com
www.HARTING.co.jp

Jemen

see United Arab Emirates

Jordan

see United Arab Emirates

Kazakhstan

see Russia

Kirghizia

see Russia

Korea (South)

HARTING Korea Limited
B-B108, Woolim Lions Valley 5th
302, Galmachi-ro, Jungwon-gu
Seongnam-si, Gyeonggi-do
462-739, Korea
Phone +82 31 750 0380
Fax +82 31 781 4616
kr@HARTING.com
www.HARTING.co.kr

Kosovo

see Austria

Kuwait

see United Arab Emirates

Latvia

see Finland

Lebanon

see United Arab Emirates

Lithuania

see Finland

Macedonia

see Austria

Malaysia (Office)

HARTING Singapore Pte Ltd
Malaysia Branch
11-02 Menara Amcorp
Jln. Persiaran Barat
46200 PJ, Sel. D. E., Malaysia
Phone +60 3 / 7955 6173
Fax +60 3 / 7955 5126
sg@HARTING.com

Montenegro

see Austria

Netherlands

HARTING B.V.
Larenweg 44
NL-5234 KA ,s-Hertogenbosch
Postbus 3526
NL-5203 DM ,s-Hertogenbosch
Phone +31 736 410 404
Fax +31 736 440 699
nl@HARTING.com
www.HARTINGbv.nl

New Zealand

see Australia

Norway

HARTING A/S
Østensjøveien 36, N-0667 Oslo
Phone +47 22 700 555
Fax +47 22 700 570
no@HARTING.com
www.HARTING.no

Oman

see United Arab Emirates

Pakistan

see United Arab Emirates

Philippines

see Malaysia



Poland

HARTING Polska Sp. z o.o.
ul. Duńska 9
PL- 54-427 Wrocław
Phone +48 71 352 81 71
Fax +48 71 350 42 13
pl@HARTING.com
www.HARTING.pl

Portugal

HARTING Iberia, S. A.
C\Viriato, 47 8º, Edificio Numancia 1
E-08014 Barcelona
Phone +351 219 673 177
Fax +351 219 678 457
es@HARTING.com
www.HARTING.es/pt

Qatar

see United Arab Emirates

Republic of Moldova

see Romania

Romania

HARTING Romania SCS
Europa Unita str. 21
550018-Sibiu, Romania
Phone +40 369-102 671
Fax +40 369-102 622
ro@HARTING.com
www.HARTING.com

Russia

HARTING ZAO
Maliy Sampsoniyevsky prospect 2A
194044 Saint Petersburg, Russia
Phone +7 812 327 6477
Fax +7 812 327 6478
ru@HARTING.com
www.HARTING.ru

Saudi Arabia

see United Arab Emirates

Serbia

see Austria

Singapore

HARTING Singapore Pte Ltd.
25 International Business Park
#04-108 German Centre
Singapore 609916
Phone +65 6225 5285
Fax +65 6225 9947
sg@HARTING.com
www.HARTING.sg

Slovakia

HARTING s.r.o.
Sales office Slovakia
J. Simora 5, SK – 940 52 Nové Zámky
Phone +421 356-493 993
Fax +421 356-402 114
sk@HARTING.com
www.HARTING.sk

Slovenia

see Austria

South Africa

HARTING South Africa (Pty) Ltd
Ground Floor, Twickenham Building
PO Box 67302
Johannesburg (Bryanston)
2021, South Africa
Phone +27 (0) 11 575 0017
Fax +27 (0) 11 576 6000
za@HARTING.com
www.HARTING.co.za

Spain

HARTING Iberia S.A.
C\Viriato, 47 8º, Edificio Numancia 1
E-08014 Barcelona
Phone +34 93 363 84 75
Fax +34 93 419 95 85
es@HARTING.com
www.HARTING.es

Sweden

HARTING AB
Gustavslundsvägen 141 B 4tr
S-167 51 Bromma
Phone +46 8 445 7171
Fax +46 8 445 7170
se@HARTING.com
www.HARTING.se

Switzerland

HARTING AG
Industriestrasse 26
CH-8604 Volketswil
Phone +41 44 908 20 60
Fax +41 44 908 20 69
ch@HARTING.com
www.HARTING.ch

Syria

see United Arab Emirates

Taiwan

HARTING Taiwan Ltd.
Room 1, 5/F
495 GuangFu South Road
RC-110 Taipei, Taiwan
Phone +886 2 2758 6177
Fax +886 2 2758 7177
tw@HARTING.com
www.HARTING.com.tw

Tajikistan

see Russia

Thailand

see Malaysia

Turkey

HARTING TURKEI Elektronik Ltd. Şti.
Barbaros Mah. Dereboyu Cad.
Fesleğen Sok.
Uphill Towers, A-1b Kat:8 D:45
34746 Ataşehir, İstanbul
Phone +90 216 688 81 00
Fax +90 216 688 81 01
tr@HARTING.com
www.HARTING.com.tr

Turkmenistan

see Russia

Ukraine

see Poland

United Arab Emirates

HARTING Middle East FZ-LLC
Knowledge Village, Block 2A, Office F72
P.O. Box 454372, Dubai
United Arab Emirates
Phone +971 4 453 9737
Fax +971 4 439 0339
uae@HARTING.com
www.HARTING.ae

USA

HARTING Inc. of North America
1370 Bowes Road
USA-Elgin, Illinois 60123
Phone +1 (877) 741-1500 (toll free)
Fax +1 (866) 278-0307 (Inside Sales)
us@HARTING.com
www.HARTING-USA.com

Uzbekistan

see Russia

Vietnam

see Singapore

Distributors – worldwide



Digi-Key Corporation:
www.digikey.com

Farnell:
www.farnell.com

FUTURE Electronics:
www.futureelectronics.com

Mouser Electronics:
www.mouser.com

RS Components:
www.rs-components.com

Other countries and general contact



HARTING Electronics GmbH
P.O. Box 1433
32328 Espelkamp – Germany
Phone +49 5772/47-97200
Fax +49 5772/47-777
electronics@HARTING.com



Pushing Performance

HARTING.com –
the gateway to your country website.

www.HARTING.ae
www.HARTING.at
www.HARTING.com.au
www.HARTING.be
www.HARTING.com.br
www.HARTING.ca
www.HARTING.ch
www.HARTING.com.cn
www.HARTING.cz
www.HARTING.de
www.HARTING.dk
www.HARTING.es
www.HARTING.fi
www.HARTING.fr
www.HARTING.co.uk
www.HARTING.com.hk
www.HARTING.hu
www.HARTING.co.in
www.HARTING.it
www.HARTING.co.jp
www.HARTING.co.kr
www.HARTINGbv.nl
www.HARTING.no
www.HARTING.pl
www.HARTING.pt
www.HARTING.ro
www.HARTING.ru
www.HARTING.se
www.HARTING.sg
www.HARTING.sk
www.HARTING.com.tr
www.HARTING.com.tw
www.HARTING-USA.com
www.HARTING.co.za