

THE INFORMATION CONTAINED HEREIN IS CONSIDERED "PROPRIETARY" TO BEL FUSE INC. AND SHALL NOT BE COPIED, REPRODUCED OR DISCLOSED WITHOUT THE WRITTEN APPROVAL OF BEL FUSE INC.

RoHS



SCHEMATIC

ELECTRICAL CHARACTERISTICS @ 25°C

URNS RATIO

TP1	1CT : 1CT	±2%
TP2	1CT : 1CT	±2%
TP3	1CT : 1CT	±2%
TP4	1CT : 1CT	±2%

QCL @ 100kHz/100mVRMS

8mA DC BIAS 350µH MIN.

INS. LOSS

0.1MHz TO 1MHz	-1.1 dB MAX
1MHz TO 65MHz	-0.5 dB MAX
65MHz TO 100MHz	-0.8 dB MAX
100MHz TO 125MHz	-1.2 dB MAX

RET. LOSS (MIN)

0.5MHz-40MHz	-18 dB
40MHz-100MHz	-12+20LOG(f/80MHz) dB

CM TO CM REJ

100kHz - 100MHz -30 dB MIN

CM TO DM REJ

100kHz - 100MHz -35 dB MIN

HIPOT (Isolation Voltage):

1500 Vrms or 2250VDC
100% OF PRODUCTION TESTED TO COMPLY WITH IEEE 802.3 ISOLATION REQUIREMENTS.

OPERATING TEMPERATURE: 0°C TO +70°C.

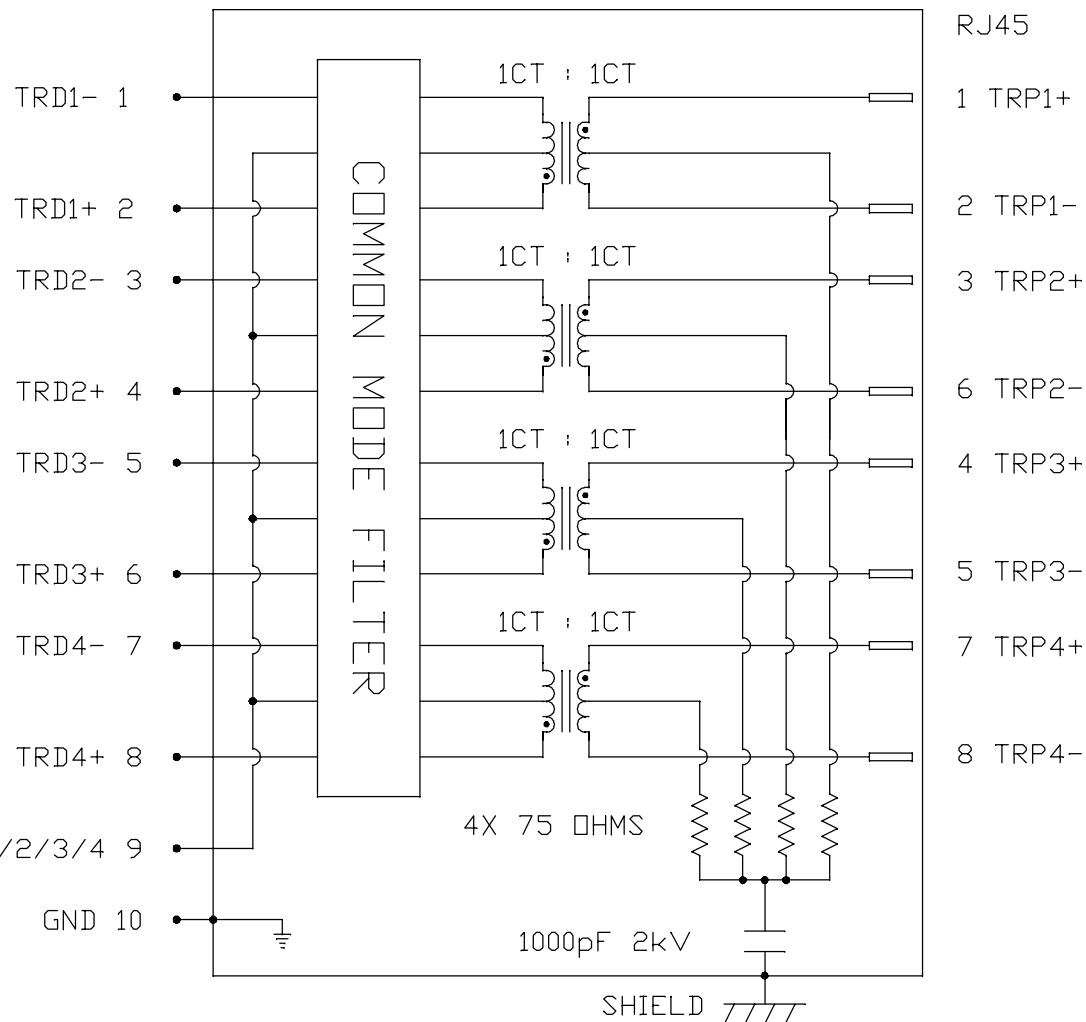

RJ45

1 TRP1+

2 TRP1-

3 TRP2+

6 TRP2-

4 TRP3+

5 TRP3-

7 TRP4+

8 TRP4-

ORIGINATED BY
CHOW WANCHUNG
DATE 2016-11-07

TITLE
2X6 gigabit MagJack®
(8 Cores)
0833-2X6R-54-F
PATENTED

DRAWN BY
LI LINFENG
DATE 2016-11-07

PART NO. / DRAWING NO.
08332X6R54-F

FILE NAME
08332X6R54-F_C.DWG

STANDARD DIM. TOL. IN INCH	[] METRIC DIM. AS REF.
.X	UNIT : INCH [mm]
.XX	SCALE : N/A
.XXX	SIZE : A4

REV. : C

PAGE : 2



a bel group

THE INFORMATION CONTAINED HEREIN IS CONSIDERED "PROPRIETARY" TO BEL FUSE INC. AND SHALL NOT BE COPIED, REPRODUCED OR DISCLOSED WITHOUT THE WRITTEN APPROVAL OF BEL FUSE INC.

RoHS

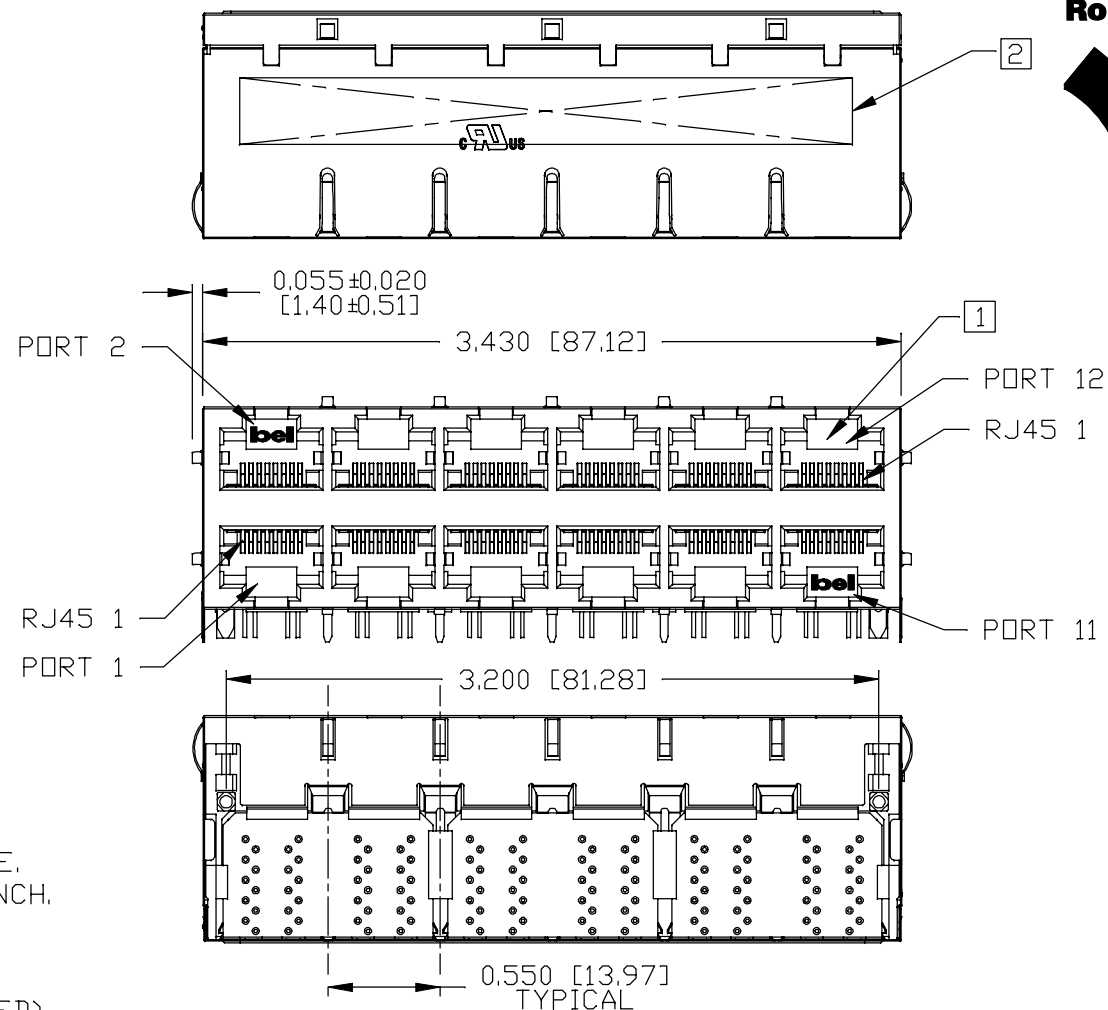
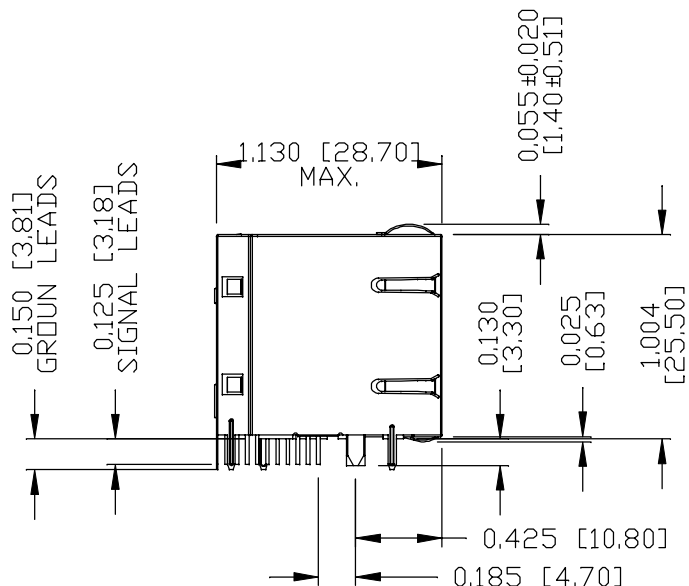

NOTES:

- PLASTIC HOUSING: THERMOPLASTIC PBT, BLACK
FLAMMABILITY RATING UL 94V-0
- CONTACT PLATING: 50 MICRO-INCH HARD GOLD PLATING
OR EQUIVALENT.
30 MICRO-INCH MIN NICKEL UNDERPLATE.
- OUTPUT PINS: TIN-COATED COPPER WIRE, DIA 0.018 INCH.
100 MICRO-INCH MIN MATTE TIN.
PINS ARE SOLDER DIPPED.
- METAL SHIELD: NICKEL PLATED ON COPPER ALLOY.
(ALL GROUND LEADS ARE SOLDER DIPPED)

- 1. JACK CAVITY CONFORMS TO FCC RULES AND REGULATIONS, PART 68 SUBPART F.
- 2. MARK PART WITH MFG LOGO, MFG NAME, PART NUMBER, DATE CODE AND PATENTED.

- 3. THE PRODUCT IS RoHS COMPLIANT.
- 4. THE PRODUCT IS PATENTED. THE PATENT NUMBER ARE U.S. PAT. 6,840,817 AND U.S. PAT. 7,123,117.
- 5. THE PRODUCT IS RECOMMENDED FOR WAVE SOLDERING PROCESS, PEAK TEMPERATURE 260°C MAX, AND 10 SECONDS MAX..

c RU us UL RECOGNIZED - FILE #E196366 AND E169987.

ORIGINATED BY
LI QUANKUN
DATE 2016-11-07
DRAWN BY
ZHANG XUEZHENG
DATE 2016-11-07

TITLE
2X6 gigabit MagJack®
(8 Cores)
0833-2X6R-54-F
PATENTED

PART NO. / DRAWING NO.
08332X6R54-F
FILE NAME
08332X6R54-F_C.DWG

STANDARD DIM. TOL. IN INCH	[] METRIC DIM. AS REF.
.X	UNIT : INCH [mm]
.XX	SCALE : N/A
.XXX	SIZE : A4

REV. : C	PAGE : 3
<p>a bel group</p>	

THE INFORMATION CONTAINED HEREIN IS CONSIDERED "PROPRIETARY" TO BEL FUSE INC. AND SHALL NOT BE COPIED, REPRODUCED OR DISCLOSED WITHOUT THE WRITTEN APPROVAL OF BEL FUSE INC.

RoHS

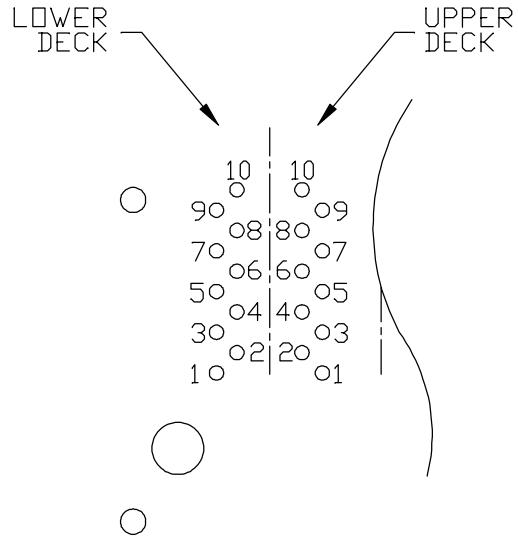

PIN-OUT INFORMATION
(COMPONENT SIDE VIEW)

10	GND
9	TRCT1/2/3/4
8	TRD 4+
7	TRD 4-
6	TRD 3+
5	TRD 3-
4	TRD 2+
3	TRD 2-
2	TRD 1+
1	TRD 1-

PORT ASSIGNMENT
(COMPONENT SIDE VIEW)

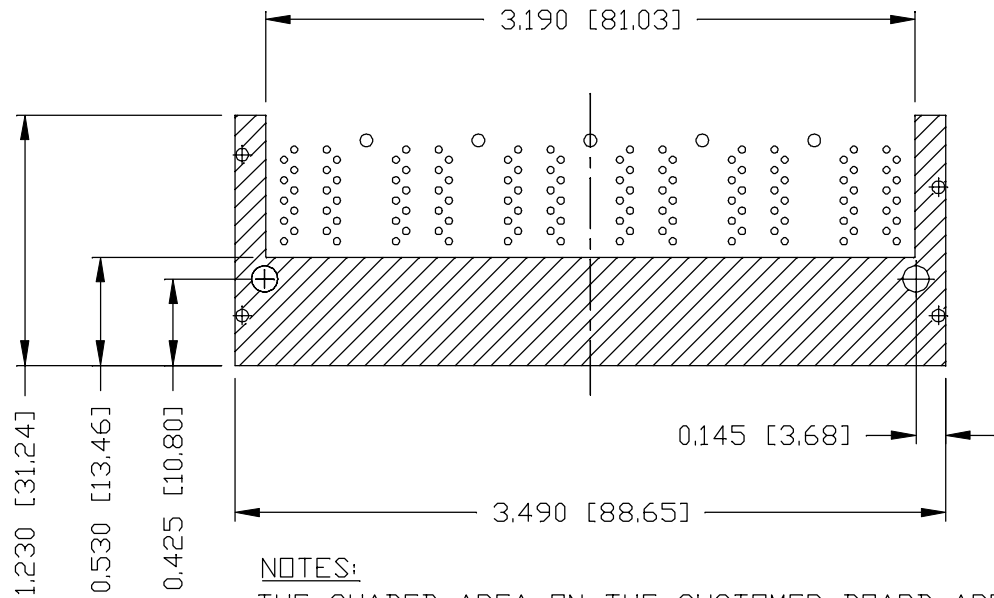
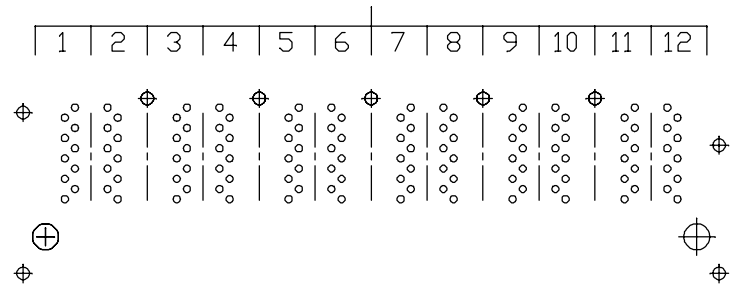

NOTES:
THE SHADED AREA ON THE CUSTOMER BOARD ARE RECOMMENDED TO BE CLEAR OFF ANY VIA HOLE OR COMPONENT PAD.

REV. : C PAGE : 4

ORIGINATED BY
LI QUANKUN
DATE 2016-11-07
DRAWN BY
ZHANG XUEZHENG
DATE 2016-11-07

TITLE
2X6 gigabit MagJack®
(8 Cores)
0833-2X6R-54-F
PATENTED

PART NO. / DRAWING NO.
08332X6R54-F
FILE NAME
08332X6R54-F_C.DWG

STANDARD DIM. TOL. IN INCH	[] METRIC DIM. AS REF.
.X	UNIT : INCH [mm]
.XX	SCALE : N/A
.XXX	SIZE : A4



THE INFORMATION CONTAINED HEREIN IS CONSIDERED "PROPRIETARY" TO BEL FUSE INC. AND SHALL NOT BE COPIED, REPRODUCED OR DISCLOSED WITHOUT THE WRITTEN APPROVAL OF BEL FUSE INC.

RoHS

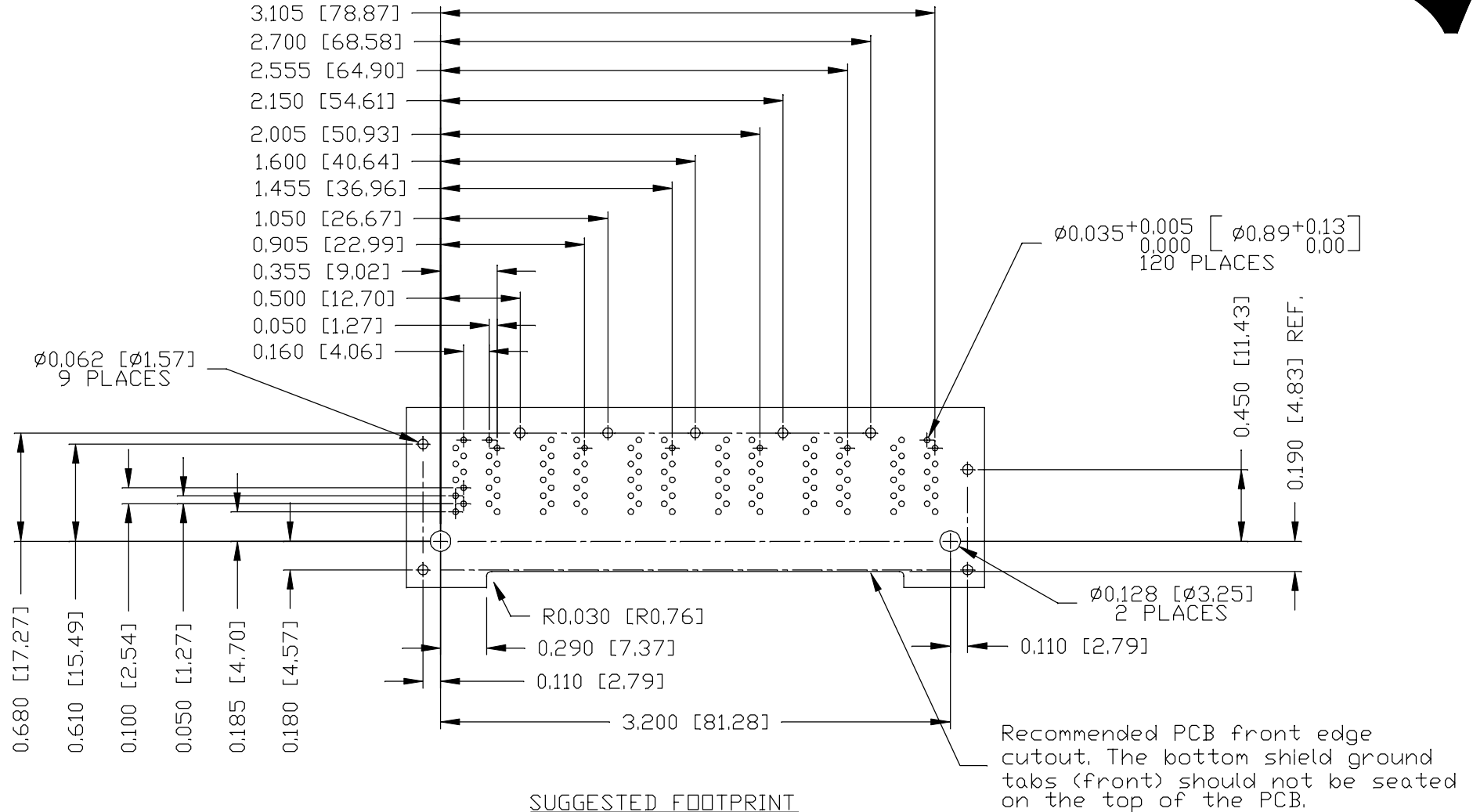

SUGGESTED FOOTPRINT
(COMPONENT SIDE VIEW)

REV. : C PAGE : 5

ORIGINATED BY
LI QUANKUN
DATE 2016-11-07
DRAWN BY
ZHANG XUEZHENG
DATE 2016-11-07

TITLE
2X6 gigabit MagJack®
(8 Cores)
0833-2X6R-54-F
PATENTED

PART NO. / DRAWING NO.
08332X6R54-F
FILE NAME
08332X6R54-F_C.DWG

STANDARD DIM. [] METRIC DIM.
TOL. IN INCH AS REF.
.X UNIT : INCH [mm]
.XX SCALE : N/A
.XXX ±0.004 SIZE : A4



THE INFORMATION CONTAINED HEREIN IS CONSIDERED "PROPRIETARY" TO BEL FUSE INC. AND SHALL NOT BE COPIED, REPRODUCED OR DISCLOSED WITHOUT THE WRITTEN APPROVAL OF BEL FUSE INC.

RoHS



SUGGESTED PANEL OPENING

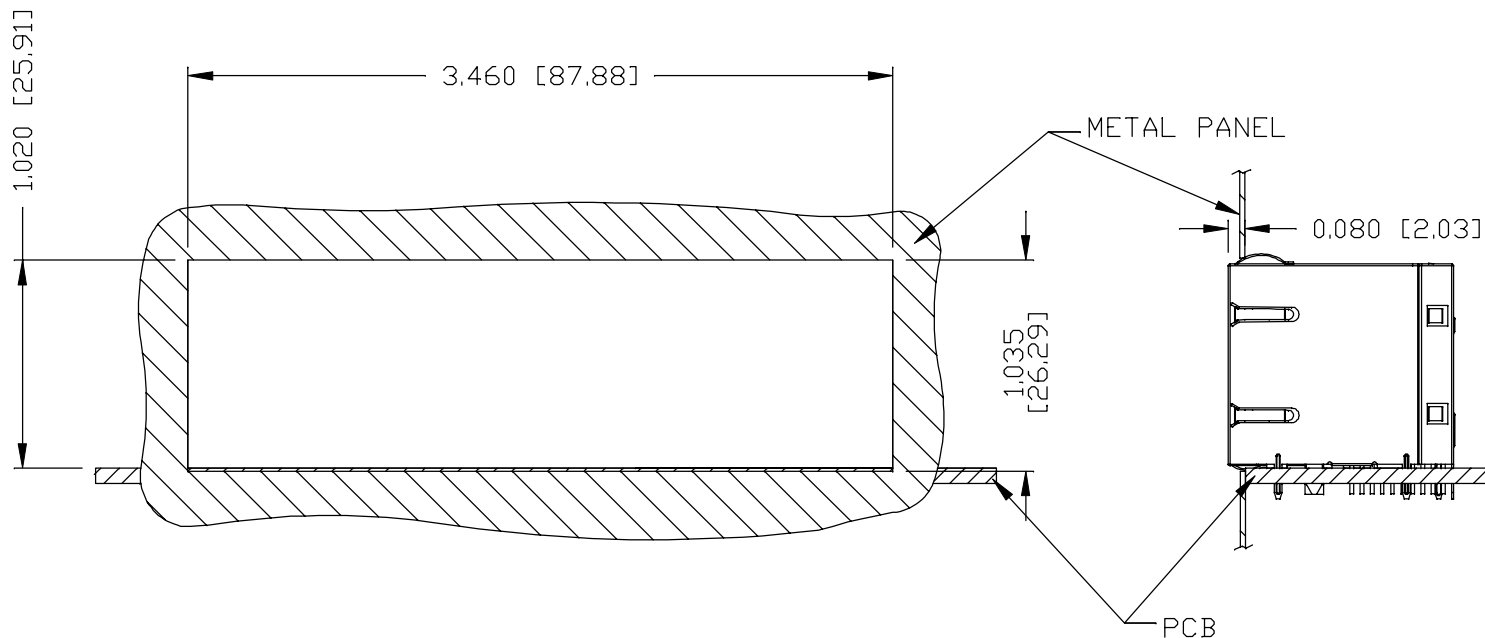

NOTE:

THE DISTANCE OF PANEL INSIDE SURFACE RELATIVE TO FRONT SURFACE OF PART IS ONLY A SUGGESTION. IN CASE THIS DISTANCE IS DIFFERENT, THE REQUIRED PANEL OPENING DIMENSIONS CHANGE ACCORDINGLY.

PACKING INFORMATION

PACKING TRAY : 0200-9999-A9 (TOP)
0200-9999-A8 (BOTTOM)

PACKING QUANTITY : 15 PCS FINISHED GOODS PER TRAY
7 TRAYS (105 PCS FINISHED GOODS) PER CARTON BOX

NOTE : CARDBOARDS ARE PLACED BETWEEN LAYERS OF PACKING TRAY INSIDE CARTON BOX
(INCLUDE THE UPPERMOST AND LOWERMOST TRAY)

REV. : C PAGE : 6

ORIGINATED BY
LI QUANKUN
DATE 2016-11-07
DRAWN BY
ZHANG XUEZHENG
DATE 2016-11-07

TITLE
2X6 gigabit MagJack®
(8 Cores)
0833-2X6R-54-F
PATENTED

PART NO. / DRAWING NO.
08332X6R54-F
FILE NAME
08332X6R54-F_C.DWG

STANDARD DIM. TOL. IN INCH		[] METRIC DIM. AS REF.
.X		UNIT : INCH [mm]
.XX		SCALE : N/A
.XXX	±0.004	SIZE : A4

