

DESCRIPTION

PMF4000 features Posifa's third-generation thermal flow die, benefiting from the latest innovations in microfabrication. The sensor die uses a pair of thermopiles to detect changes in temperature gradient caused by mass flow, delivering excellent signal-to-noise and repeatability. The "solid state" thermal isolation structure on the sensor die eliminates the need for surface cavity or fragile membrane used in competing technologies, making the sensor resistant to clogging and pressure shock.

The PMF4000 series includes the analog output PMF4000V and the digital I²C output PMF4000D.

The supported max flow rates range from 12 SLM to 300 SLM. The sensors are temperature compensated over the temperature range of 0 to 50 °C. The linearized output provides maximum flexibility and ease-of-use.

APPLICATIONS

- Oxygen concentrators
- Respirators and ventilators
- Nebulizers
- CPAP equipment
- Anesthesia delivery
- Leak detection
- Spectroscopy
- Mass flow controller
- Fuel cell control



FEATURES

- Unsurpassed performance in a robust and cost effective package
- "Solid state" sensing core (no surface cavity or fragile membrane) resistant to clogging and pressure shock
- Highly accurate (4% reading typ.)
- Fast response time (5 ms typ.)
- Linear output and temperature compensation
- Long-term stability with minimal null drift
- Wiring harness with pre-installed receptacle (analog version only)

MAXIMUM RATINGS

- Operating Temperature: -25 to 85 °C
- Calibrated Temperature Range: 0 to 50 °C
- Storage Temperature: -40 to 90 °C
- Humidity: 0 to 100% RH, non-condensing
- Shock: 100 g peak (5 drops, 3 axis)
- Operating Pressure: 25 psi

SPECIFICATIONS

Test Conditions: $V_{in}=10\pm 0.01V_{DC}$, $T_a=25^{\circ}C$. Relative Humidity: $40\% < RH < 60\%$					
SPECIFICATIONS	MIN	TYP	MAX	UNIT	CONDITIONS
PMF4003	0		12	SLM	
PMF4004	0		20	SLM	
PMF4005	0		35	SLM	
PMF4100	0		50	SLM	
PMF4101	0		100	SLM	
PMF4102	0		150	SLM	
PMF4103	0		200	SLM	
PMF4104	0		300	SLM	
PMF4105	0		250	SLM	
Output Voltage (V)²					
	1 to 5			VDC	
Null Voltage (V)	0.95	1	1.05	VDC	
Output Count (D)					
	256 to 16124			Count	
Null Count	156		356	Count	
Null Drift			0.2	% F.S.	Per year
Repeatability		0.1		% F.S.	
Accuracy ³		1%		F.S.	0 to 25% F.S.
		4%		Reading	25 to 100% F.S.
Resolution (D)		14		Bit	
Response Time ⁴		5		mSec	
Supply Voltage (V)	6	10	16	Vdc	
Supply Voltage (D)	4.75		16	Vdc	
Current		21	26	mA	
Wetted Materials	Silicon carbide, epoxy, PPE+PE, FR4, and silicone as static seal				

1. SLM: standard liter per minute. Standard conditions: 0 °C and 1 atmosphere.
2. V refers to the analog version of PMF4000, and D refers to the digital I2C version.
3. Maximum deviation in output from nominal over the entire calibrated flow range and temperature range. Errors include offset, full scale span, linearity, flow hysteresis, repeatability and temperature effects over the compensated temperature range.
4. 10% to 90% rise time of the flow sensor to electrically respond to any mass flow change. May be affected by the pneumatic interface.

OUTPUT DESCRIPTION

For **PMF4000V**

Flow Rate = $[(V_{out} - 1 V) / 4 V] \times \text{Full Scale Flow Rate}$

For example, for PMF4101V full scale flow rate is 100 SLM. When Vout reads 3 V, the Flow Rate is: $[(3 V - 1 V) / 4 V \times 100 \text{ SLM}] = 50 \text{ SLM}$

For **PMF4000D**

Flow Rate = $[(\text{Count} - 256) / 15868] \times \text{Full Scale Flow Rate}$

For example, for PMF4101D full scale rate is 100 SLM. When digital output reads 10000, the Flow Rate is:

$[(10000 - 256) / 15868 \times 100 \text{ SLM}] = 61.41 \text{ SLM}$

*Contact Posifa for I²C Communication app note.

PACKAGE DIMENSIONS

PMF4000V

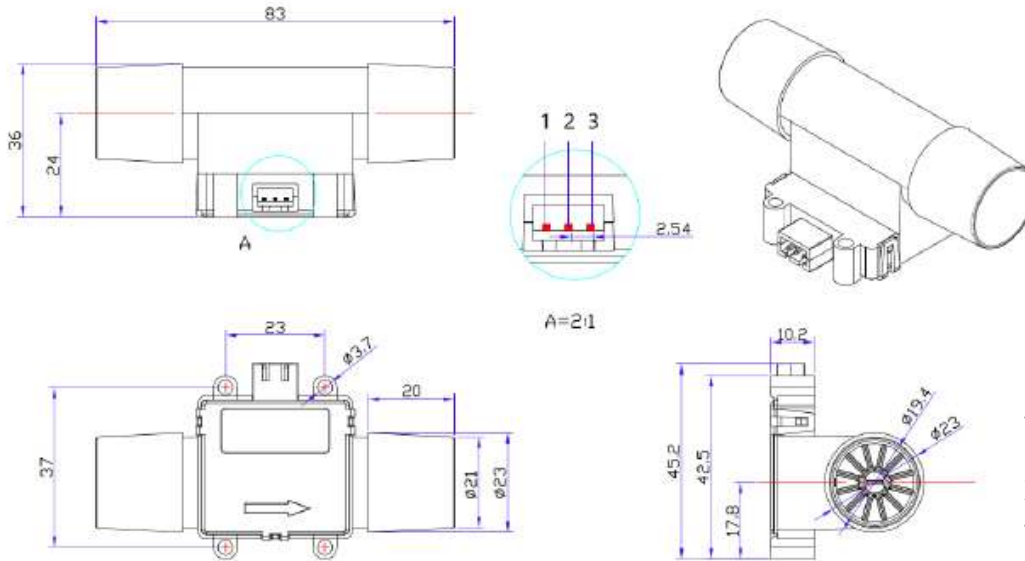

Pin#	Description
1	OUT
2	VDD
3	GND

Notes:

1. Mating connector with 30 cm pigtail is provided
2. Color scheme: Vout - white, Vin - red, GND - black
3. Mating connector: JST XHP-3 or Equivalent
4. Fitting: 22 mm medical connector perISO 5356
5. Unit: mm

Please contact Posifa for sensor CAD model

PMF4000D

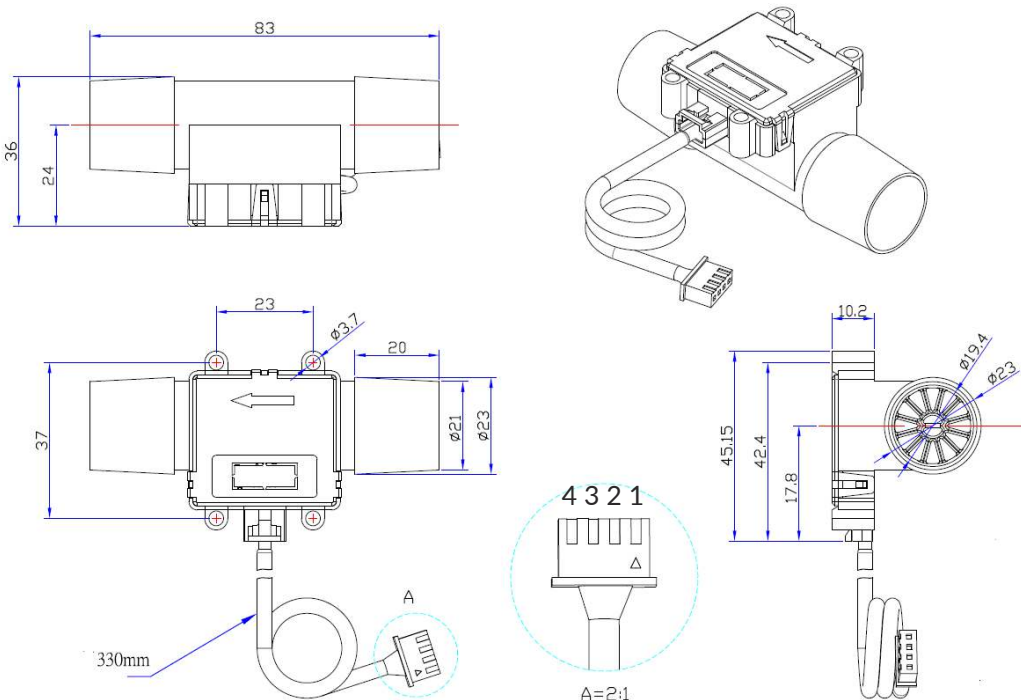

Pin#	Description
1	SDA
2	SCL
3	VDD
4	GND

Notes:

1. Mating connector: AMP 487545-2 or Equivalent
2. Fitting: 22 mm medical connector per ISO 5356
3. Unit: mm

ORDERING INFORMATION

PART NUMBER	SPECIFICATIONS
PMF4003D	12 SLM, I ² C, Linear
PMF4004D	20 SLM, I ² C, Linear
PMF4005D	35 SLM, I ² C, Linear
PMF4100D	50 SLM, I ² C, Linear
PMF4101D	100 SLM, I ² C, Linear
PMF4102D	150 SLM, I ² C, Linear
PMF4103D	200 SLM, I ² C, Linear
PMF4104D	300 SLM, I ² C, Linear
PMF4105D	250 SLM, I ² C, Linear

Order 1 to 5V Analog output models by specifying "V" instead of "D" in p/n's above.
Please contact Posifa or your local distributor to place an order.

EUROPEAN DISTRIBUTOR

BS-rep GmbH
Eichertstr. 68, D-56745 Weibern, Germany
Tel: +49 (0) 2655 / 96 26 476
Email: info@sensor-rep.de

CUSTOMIZATION OPTIONS

If the standard product described in this datasheet does not completely meet your needs, please contact Posifa Technologies to discuss other options. Help us understand your application and sensor requirements and we can work together to find the best overall solution.