

PI6C4911504-03

High Performance LVPECL Fanout Buffer

Features

- 4 LVPECL Outputs
- Up to 1.5GHz Output Frequency
- Ultra Low Additive Phase Jitter: < 0.03 ps (typ) (differential 156.25MHz, 12KHz to 20MHz integration range)
- Two selectable inputs
- Low delay from input to output (Tpd typ. 1.5ns)
- 2.5V / 3.3V power supply
- Industrial temperature support
- Totally Lead-Free & Fully RoHS Compliant (Notes 1 & 2)
- Halogen and Antimony Free. “Green” Device (Note 3)
- For automotive applications requiring specific change control (i.e. parts qualified to AEC-Q100/101/200, PPAP capable, and manufactured in IATF 16949 certified facilities), please [contact us](https://www.diodes.com/contact-us) or your local Diodes representative.
<https://www.diodes.com/quality/product-definitions/>
- Packaging (Pb-free & Green):
 - 20-pin, TSSOP (L)

Applications

- Networking systems including switches and Routers
- High frequency backplane based computing and telecom platforms

Description

The PI6C4911504-03 is a high performance fanout buffer device which supports up to 1.5GHz frequency. PI6C4911504-03 features selectable single-ended clock or crystal inputs and translates to four LVPECL outputs. The outputs are synchronized with input clock during asynchronous assertion /deassertion of CLK_EN pin. PI6C4911504-03 is ideal for crystal or LVCMOS/LVTTL to LVPECL translation. Typical clock translation and distribution applications are data-communications and telecommunications. This device is ideal for systems that need to distribute low jitter clock signals to multiple destinations.

Block Diagram

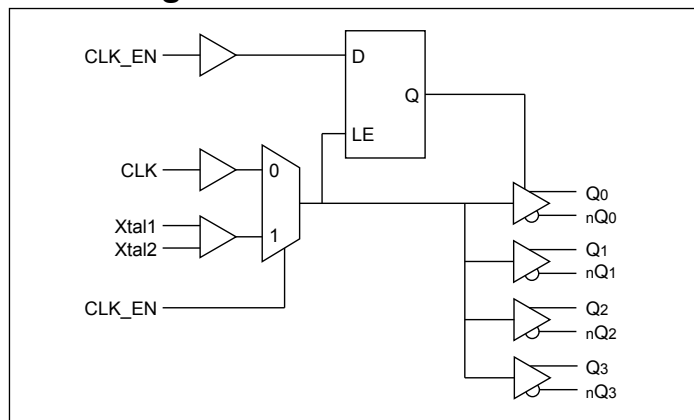

Notes:

1. No purposely added lead. Fully EU Directive 2002/95/EC (RoHS), 2011/65/EU (RoHS 2) & 2015/863/EU (RoHS 3) compliant.
2. See <https://www.diodes.com/quality/lead-free/> for more information about Diodes Incorporated’s definitions of Halogen- and Antimony-free, “Green” and Lead-free.
3. Halogen- and Antimony-free “Green” products are defined as those which contain <900ppm bromine, <900ppm chlorine (<1500ppm total Br + Cl) and <1000ppm antimony compounds.

Pin Configuration

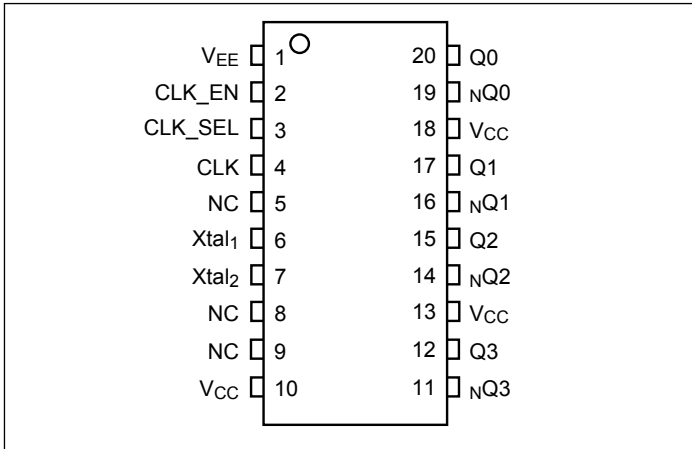

Pin Description

Pin #	Pin Name	Type	Description
1	V _{EE}	Power	Negative power supply
2	CLK_EN	Input Pullup	Clock output enable/ disable
3	CLK_SEL	Input Pulldown	Clock input source selection pin
4	CLK	Input Pulldown	Clock input
5	NC	-	No Connect
6	XTAL1	Input	Xtal input
7	XTAL2	Output	Xtal output
8, 9	NC	-	No connect
10, 13, 18	V _{CC}	Power	Power supply
11, 12	nQ3 Q3	Output	LVPECL output clock
14, 15	nQ2 Q2	Output	LVPECL output clock
16, 17	nQ1 Q1	Output	LVPECL output clock
19, 20	nQ0 Q0	Output	LVPECL output clock

Note: Pullup and Pulldown are for internal input resistors

Function Table

Table 1: Clock source input select function

CLK_SEL	Function
0	CLK is the selected reference input
1	XTAL is the selected input

Table 2: Clock output select function

CLK_EN	Function
0	All outputs disabled. Qx disabled low, nQx disabled High
1	All outputs enabled.

Maximum Ratings (Above which the useful life may be impaired. For user guidelines, not tested)

Storage temperature.....	-55 to +150°C
Supply Voltage to Ground Potential (VCC).....	-0.5 to +4.65V
Inputs (Referenced to GND)	-0.5 to V _{CC} +0.5V
Clock Output (Referenced to GND).....	-0.5 to V _{CC} +0.5V
Soldering Temperature (Max of 10 seconds)	+260°C
Latch up	200mA
Junction Temperature	Max. 125°C

Note:

Stresses greater than those listed under MAXIMUM RATINGS may cause permanent damage to the device. This is a stress rating only and functional operation of the device at these or any other conditions above those indicated in the operational sections of this specification is not implied. Exposure to absolute maximum rating conditions for extended periods may affect reliability.

Power Supply Characteristics and Operating Conditions

Symbol	Parameter	Test Condition	Min.	Typ.	Max.	Units
V _{CC}	Supply Voltage		3.135		3.465	V
			2.375		2.625	V
I _{DD}	Power Supply Current	All outputs unloaded			130	mA
T _A	Ambient Operating Temperature		-40		85	°C

DC Electrical Specifications - LVCMOS Inputs

Symbol	Parameter	Conditions		Min.	Typ.	Max.	Units
V _{IH}	Input high voltage		V _{CC} =3.3V	2.0		V _{CC} +0.3	V
V _{IL}	Input low voltage		V _{CC} =3.3V	-0.3		0.8	V
V _{IH}	Input high voltage		V _{CC} =2.5V	1.7		V _{CC} +0.3	V
V _{IL}	Input low voltage		V _{CC} =2.5V	-0.3		0.7	V
I _{IH}	Input High current	CLK, CLK_SEL				150	uA
		CLK_EN				10	uA
I _{IL}	Input Low current	CLK, CLK_SEL		-10			uA
		CLK_EN		-150			uA
C _{IN}	Input capacitance				4		pF
R _{PULLUP/PULL-DOWN}	Input pullup and pulldown resistor				50		kΩ

DC Electrical Specifications- LVPECL Outputs

Parameter	Description	Conditions	Min.	Typ.	Max.	Units
V _{OH}	Output High voltage	V _{CC} =3.3V	2.1		2.6	V
		V _{CC} =2.5V	1.3		1.75	
V _{OL}	Output Low voltage	V _{CC} =3.3V	1.0		1.8	V
		V _{CC} =2.5V	0.4		0.8	

AC Electrical Specifications – Differential Outputs

Parameter	Description	Conditions	Min.	Typ.	Max.	Units
F _{OUT}	Clock output frequency	LVPECL			1500	MHz
T _r	Output rise time	From 20% to 80%		150		ps
T _f	Output fall time	From 80% to 20%		150		ps
T _{ODC}	Output duty cycle		48		52	%
V _{PP}	Output swing Single-ended	LVPECL outputs	400			mV
T _j	Buffer additive jitter RMS			0.03		ps
T _{SK}	Output Skew	4 outputs devices, outputs in same bank, with same load, at DUT.		25		ps
T _{PD}	Propagation Delay			1500		ps
T _{OD}	Valid to HiZ		200			ns
T _{OE}	HiZ to valid		200			ns

Notes:

All parameters are measured with CMOS input of 266MHz unless stated otherwise

Crystal Characteristics

Parameters	Test Conditions	Min.	Typ.	Max.	Units
Mode of Oscillation		Fundamental			
Frequency		12		50	MHz
Equivalent Series Resistance (ESR)				50	Ω
Shunt Capacitance				7	pF
Drive Level				1	mW

PI6C4911504-03

Propagation Delay

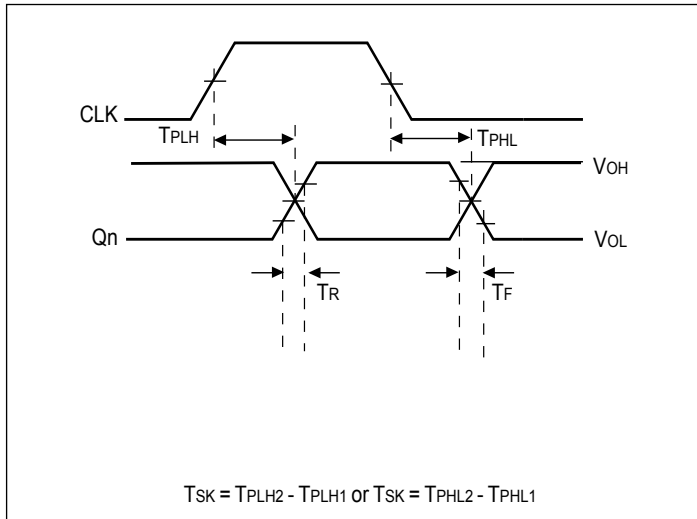

Output Skew

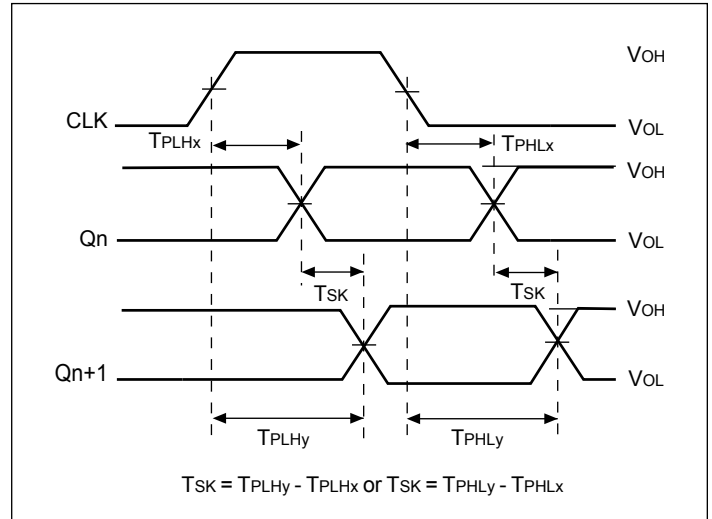

Configuration Test Load Board Termination for LVPECL

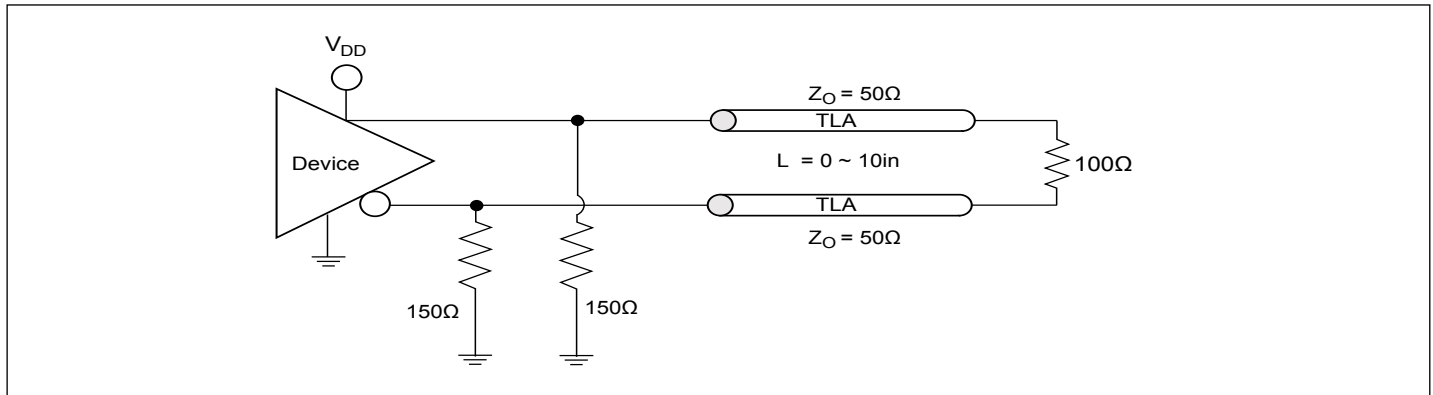

Part Marking

PI6C4911
504-03LIE
ZYYWWXX

Z: Die Rev
YY: Year
WW: Workweek
1st X: Assembly Code
2nd X: Fab Code

Packaging Mechanical: 20-TSSOP (L)

SYMBOLS	MIN.	NOM.	MAX.
A	–	–	1.20
A1	0.05	–	0.15
A2	0.80	1.00	1.05
b	0.19	–	0.30
C	0.09	–	0.20
D	6.40	6.50	6.60
E1	4.30	4.40	4.50
E	6.20	6.40	6.60
e	0.65 BSC		
L1	1.00 REF		
L	0.45	0.60	0.75
S	0.20	–	–
θ	0°	–	8°

NOTES:
 1. ALL DIMENSIONS IN MILLIMETERS. ANGLES IN DEGREES.
 2. JEDEC MO-153F
 3. DIMENSIONS DOES NOT INCLUDE MOLD FLASH, PROTRUSIONS OR GATE BURRS.

		DATE: 03/31/16
DESCRIPTION: 20-Pin, 173mil Wide TSSOP		
PACKAGE CODE: L (L20)		
DOCUMENT CONTROL #: PD-1311	REVISION: G	

16-0074

For latest package info.

please check: <http://www.diodes.com/design/support/packaging/pericom-packaging/packaging-mechanicals-and-thermal-characteristics/>

Ordering Information

Ordering Number	Package Code	Package Description
PI6C4911504-03LIEX	L	20-Pin, 173mil Wide (TSSOP)

Notes:

1. No purposely added lead. Fully EU Directive 2002/95/EC (RoHS), 2011/65/EU (RoHS 2) & 2015/863/EU (RoHS 3) compliant.
2. See <https://www.diodes.com/quality/lead-free/> for more information about Diodes Incorporated's definitions of Halogen- and Antimony-free, "Green" and Lead-free.
3. Halogen- and Antimony-free "Green" products are defined as those which contain <900ppm bromine, <900ppm chlorine (<1500ppm total Br + Cl) and <1000ppm antimony compounds.
4. E = Pb-free and Green
5. X suffix = Tape/Reel

IMPORTANT NOTICE

1. DIODES INCORPORATED AND ITS SUBSIDIARIES (“DIODES”) MAKE NO WARRANTY OF ANY KIND, EXPRESS OR IMPLIED, WITH REGARDS TO ANY INFORMATION CONTAINED IN THIS DOCUMENT, INCLUDING, BUT NOT LIMITED TO, THE IMPLIED WARRANTIES OF MERCHANTABILITY, FITNESS FOR A PARTICULAR PURPOSE OR NON-INFRINGEMENT OF THIRD PARTY INTELLECTUAL PROPERTY RIGHTS (AND THEIR EQUIVALENTS UNDER THE LAWS OF ANY JURISDICTION).

2. The Information contained herein is for informational purpose only and is provided only to illustrate the operation of Diodes products described herein and application examples. Diodes does not assume any liability arising out of the application or use of this document or any product described herein. This document is intended for skilled and technically trained engineering customers and users who design with Diodes products. Diodes products may be used to facilitate safety-related applications; however, in all instances customers and users are responsible for (a) selecting the appropriate Diodes products for their applications, (b) evaluating the suitability of the Diodes products for their intended applications, (c) ensuring their applications, which incorporate Diodes products, comply the applicable legal and regulatory requirements as well as safety and functional-safety related standards, and (d) ensuring they design with appropriate safeguards (including testing, validation, quality control techniques, redundancy, malfunction prevention, and appropriate treatment for aging degradation) to minimize the risks associated with their applications.

3. Diodes assumes no liability for any application-related information, support, assistance or feedback that may be provided by Diodes from time to time. Any customer or user of this document or products described herein will assume all risks and liabilities associated with such use, and will hold Diodes and all companies whose products are represented herein or on Diodes' websites, harmless against all damages and liabilities.

4. Products described herein may be covered by one or more United States, international or foreign patents and pending patent applications. Product names and markings noted herein may also be covered by one or more United States, international or foreign trademarks and trademark applications. Diodes does not convey any license under any of its intellectual property rights or the rights of any third parties (including third parties whose products and services may be described in this document or on Diodes' website) under this document.

5. Diodes products are provided subject to Diodes' Standard Terms and Conditions of Sale (<https://www.diodes.com/about/company/terms-and-conditions/terms-and-conditions-of-sales/>) or other applicable terms. This document does not alter or expand the applicable warranties provided by Diodes. Diodes does not warrant or accept any liability whatsoever in respect of any products purchased through unauthorized sales channel.

6. Diodes products and technology may not be used for or incorporated into any products or systems whose manufacture, use or sale is prohibited under any applicable laws and regulations. Should customers or users use Diodes products in contravention of any applicable laws or regulations, or for any unintended or unauthorized application, customers and users will (a) be solely responsible for any damages, losses or penalties arising in connection therewith or as a result thereof, and (b) indemnify and hold Diodes and its representatives and agents harmless against any and all claims, damages, expenses, and attorney fees arising out of, directly or indirectly, any claim relating to any noncompliance with the applicable laws and regulations, as well as any unintended or unauthorized application.

7. While efforts have been made to ensure the information contained in this document is accurate, complete and current, it may contain technical inaccuracies, omissions and typographical errors. Diodes does not warrant that information contained in this document is error-free and Diodes is under no obligation to update or otherwise correct this information. Notwithstanding the foregoing, Diodes reserves the right to make modifications, enhancements, improvements, corrections or other changes without further notice to this document and any product described herein. This document is written in English but may be translated into multiple languages for reference. Only the English version of this document is the final and determinative format released by Diodes.

8. Any unauthorized copying, modification, distribution, transmission, display or other use of this document (or any portion hereof) is prohibited. Diodes assumes no responsibility for any losses incurred by the customers or users or any third parties arising from any such unauthorized use.

Copyright © 2021 Diodes Incorporated

www.diodes.com