

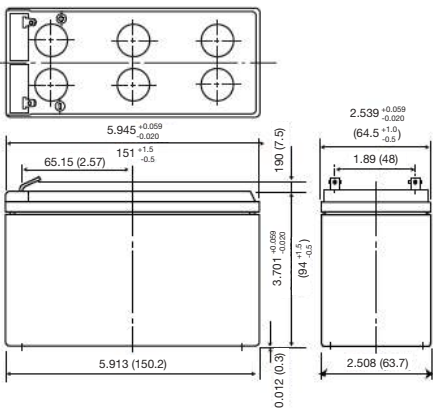

Dimensions

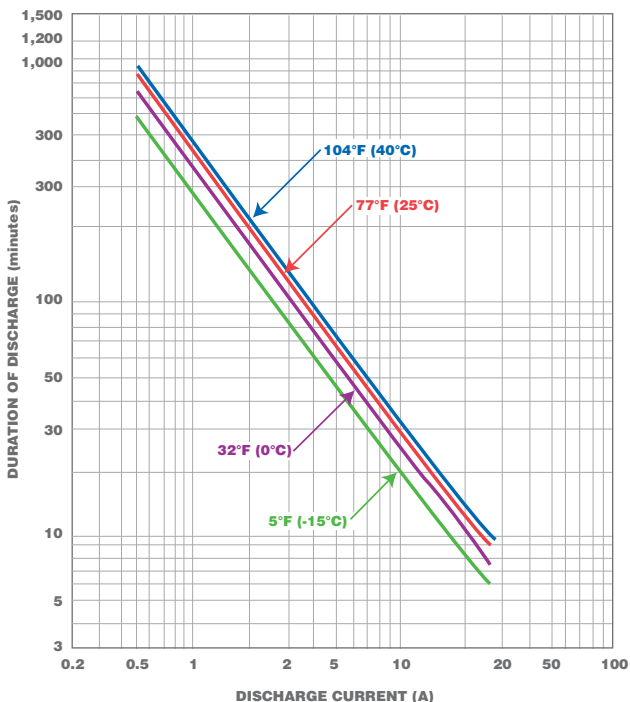

Duration of Discharge vs. Discharge Current



Features & Benefits

- High quality and reliability
- Exceptional deep discharge recovery
- No corrosive gas generation
- Long service life
- Quick chargeability
- High power density
- Maintenance-free operation

Specifications

Nominal Voltage:	12V	
Weight:	2.6 kg	
Standard Terminals & Resin	UL94 V-0 Faston 250	
Capacity 77°F (25°C) (9.6V cutoff):	30 min. rate	112W
	15 min. rate	195W
	10 min. rate	268W
	5 min. rate	410W
Internal Resistance:	Fully charged battery 77°F (25°C)	Approx. 21mΩ
Temperature dependency of capacity (20 hour rate):	104°F (40°C)	102%
	77°F (25°C)	100%
	32°F (0°C)	85%
	5°F (-15°C)	65%
Self discharge 77° (25°C):	Residual capacity after standing 3 mos.	91%
	Residual capacity after standing 6 mos.	82%
	Residual capacity after standing 12 mos.	64%
Charge Method (Constant Voltage):	Initial current	1.25A or smaller
	Trickle use	13.6V to 13.8V (per 12V cell 25°C)
	Control Voltage	(per 12V cell 25°C)

Discharge Characteristics 77°F (25°C)

