

For New Designs we Recommend 04028DA

General Specifications

Motor Protection:

Auto Restart/Polarity Protection/Hot Swap: Available

Insulation Resistance:

min 10M Ω by DC500V Megger

Dielectric Withstand Voltage: AC 700V 1s

Allowable Ambient Temperature Range:

-10°C ~ +70°C (Operating)

-40°C ~ +70°C (Storage)

(non-condensing environment)

Expected Life

Failure Rate: 10%

25°C 80,000 Hours

Characteristic Curves

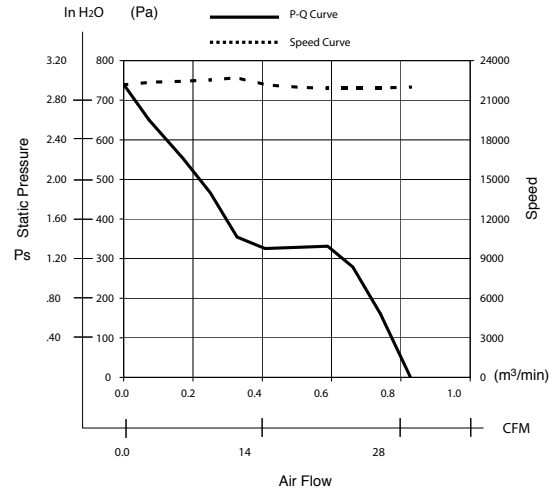

Outline

Units: $\frac{\text{inch}}{\text{mm}}$

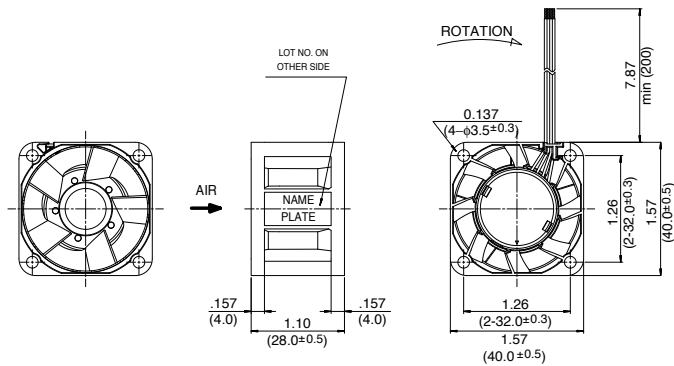

Panel Cut-outs

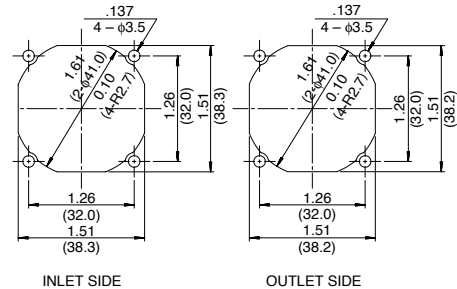

Material

- Casing : Plastic (Black) 94V-0
- Impeller : Plastic (Black) 94V-0
- Bearing : Ball Bearing
- Lead Wire: UL10368, AWG26, +Red, -Black
- Tach Sig. : White PWM Control : Brown

PWM Control Voltage

- Vst = 0V ~ 0.3V Low Speed Duty 0%
- Vst = 4.0V ~ 5.0V High Speed Duty 100%
- Vst = Open High Speed Duty 100%
- I_{PWM} = max 2.0mA
- (At Ta = 25°C, rated voltage + 12VDC and f=25 kHz)

Reference PWM Duty vs Speed Curve

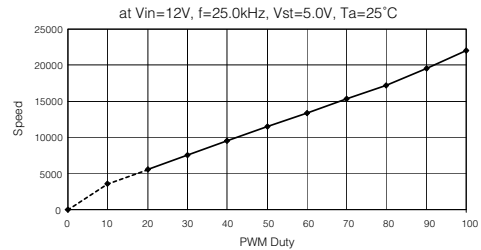

Specifications

MODEL	Product No.	Rated Voltage	Operating Voltage	Current	Input Power	Speed	Max. Flow		Max. Static Pressure		Noise	Mass
		(V)	(V)	(A) ^{*1}	(W) ^{*1}	(min ⁻¹) ^{*1}	Air CFM ^{*1}	(m ³ /min) ^{*1}	in H ₂ O	(Pa) ^{*1}	(dB) ^{*1}	(g)
1611FT-D4W-B86-	BXX	12	10.8 ~ 13.2	.95	11.40	22,000	29.3	.83	2.68	670.0	60.0	49

Rotation: Clockwise

Airflow Outlet: Air Out Over Struts

*1: Average Values in Free Air

