

MIMX8MQ6DVAJZAA MIMX8MQ6DVAJZAB
MIMX8MQ5DVAJZAA MIMX8MQ5DVAJZAB
MIMX8MQ6DVAJZIB MIMX8MD6DVAJZAA
MIMX8MD6DVAJZAB

i.MX 8M Dual / 8M QuadLite / 8M Quad Applications Processors Data Sheet for Consumer Products

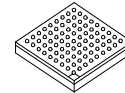

Package Information
Bare Die Package
FBGA 17 x 17 mm, 0.65 mm pitch

Ordering Information
See Table 2 on page 6

1 i.MX 8M Dual / 8M QuadLite / 8M Quad introduction

The i.MX 8M Dual / 8M QuadLite / 8M Quad processors represent NXP's latest market of connected streaming audio/video devices, scanning/imaging devices, and various devices requiring high-performance, low-power processors.

The i.MX 8M Dual / 8M QuadLite / 8M Quad processors feature advanced implementation of a quad Arm® Cortex®-A53 core, which operates at speeds of up to 1.5 GHz. A general purpose Cortex®-M4 core processor is for low-power processing. The DRAM controller supports 32-bit/16-bit LPDDR4, DDR4, and DDR3L memory. There are a number of other interfaces for connecting peripherals, such as WLAN, Bluetooth, GPS, displays, and camera sensors. The i.MX 8M Quad and i.MX 8M Dual processors have hardware acceleration for video playback up to 4K, and can drive the video outputs up to 60 fps. Although the i.MX 8M QuadLite processor does not have hardware acceleration for video decode, it allows for video playback with software decoders if needed.

1. i.MX 8M Dual / 8M QuadLite / 8M Quad introduction	1
1.1. Block diagram	5
1.2. Ordering information	6
2. Modules list	8
2.1. Recommended connections for unused interfaces	12
3. Electrical characteristics	13
3.1. Chip-level conditions	13
3.2. Power supplies requirements and restrictions	27
3.3. PLL electrical characteristics	29
3.4. On-chip oscillators	30
3.5. I/O DC parameters	32
3.6. I/O AC parameters	34
3.7. Output buffer impedance parameters	37
3.8. System modules timing	39
3.9. External peripheral interface parameters	40
4. Boot mode configuration	76
4.1. Boot mode configuration pins	76
4.2. Boot device interface allocation	77
5. Package information and contact assignments	78
5.1. 17 x 17 mm package information	78
5.2. DDR pin function list for 17 x 17 mm package	98
6. Revision history	101



Table 1. Features

Subsystem	Feature
Arm Cortex-A53 MPCore platform	Quad symmetric Cortex-A53 processors: <ul style="list-style-type: none"> • 32 KB L1 Instruction Cache • 32 KB L1 Data Cache • Support L1 cache RAMs protection with parity/ECC
	Support of 64-bit Armv8-A architecture: <ul style="list-style-type: none"> • 1 MB unified L2 cache • Support L2 cache RAMs protection with ECC • Frequency of 1.5 GHz
Arm Cortex-M4 core platform	16 KB L1 Instruction Cache
	16 KB L1 Data Cache
	256 KB tightly coupled memory (TCM)
Connectivity	Two PCI Express Gen2 interfaces
	Two USB 3.0/2.0 controllers with integrated PHY interfaces
	Two Ultra Secure Digital Host Controller (uSDHC) interfaces
	One Gigabit Ethernet controller with support for IEEE 1588, Ethernet AVB, and IEEE 1588
	Four Universal Asynchronous Receiver/Transmitter (UART) modules
	Four I ² C modules
	Three SPI modules
External memory interface	32/16-bit DRAM interface: LPDDR4-3200, DDR4-2400, DDR3L-1600
	8-bit NAND-Flash
	eMMC 5.0 Flash
	SPI NOR Flash
	QuadSPI Flash with support for XIP
GPIO and pin multiplexing	GPIO modules with interrupt capability
	Input/output multiplexing controller (IOMUXC) to provide centralized pad control
On-chip memory	Boot ROM (128 KB)
	On-chip RAM (128 KB + 32 KB)
Power management	Temperature sensor with programmable trip points
	Flexible power domain partitioning with internal power switches to support efficient power management

Table 1. Features (continued)

Subsystem	Feature
Multimedia	Video Processing Unit: <ul style="list-style-type: none"> • 4Kp60 HEVC/H.265 main, and main 10 decoder • 4Kp60 VP9 decoder • 4Kp30 AVC/H.264 decoder • 1080p60 MPEG-2, MPEG-4p2, VC-1, VP8, RV9, AVS, MJPEG, H.263 decoder
	Graphic Processing Unit: <ul style="list-style-type: none"> • 4 shader • 267 million triangles/sec • 1.6 Giga pixel/sec • 32 GFLOPs 32-bit or 64 GFLOPs 16-bit • Support OpenGL ES 1.1, 2.0, 3.0, 3.1, Open CL 1.2, and Vulkan
	HDMI Display Interface: <ul style="list-style-type: none"> • HDMI 2.0a supporting one display: resolution up to 4096 x 2160 at 60 Hz, support HDCP 2.2 and HDCP 1.4¹ • 20+ Audio interfaces 32-bit @ 384 kHz fs, with Time Division Multiplexing (TDM) support • S/PDIF input and output • Audio Return Channel (ARC) on HDMI • Upscale HD graphics to 4K for display • Downscale 4K video to HD for display • Display Port • Embedded Display Port
	MIPI-DSI Display Interface: <ul style="list-style-type: none"> • MIPI-DSI 4 channels supporting one display, resolution up to 1920 x 1080 at 60 Hz • LCDIF display controller • Output can be LCDIF output or DC display controller output
	Audio: <ul style="list-style-type: none"> • S/PDIF input and output • Five synchronous audio interface (SAI) modules supporting I2S, AC97, TDM, and codec/DSP interfaces, including one SAI with 16 Tx and 16 Rx channels, one SAI with 8 Tx and 8 Rx channels, and three SAI with 2 Tx and 2 Rx channels • One SAI for 8 Tx channels for HDMI output audio • One S/PDIF input for HDMI ARC input
	Camera inputs: <ul style="list-style-type: none"> • Two MIPI-CSI2 camera inputs (4-lane each)
	Security
Arm TrustZone (TZ) architecture	
On-chip RAM (OCRAM) secure region protection using OCRAM controller	
High Assurance Boot (HAB)	
Cryptographic acceleration and assurance (CAAM) module	
Secure non-volatile storage (SNVS): Secure real-time clock (RTC)	
Secure JTAG controller (SJC)	

Table 1. Features (continued)

Subsystem	Feature
System debug	Arm CoreSight debug and trace architecture
	TPIU to support off-chip real-time trace
	ETF with 4 KB internal storage to provide trace buffering
	Unified trace capability for Quad Cortex-A53 and Cortex-M4 CPUs
	Cross Triggering Interface (CTI)
	Support for 5-pin (JTAG) debug interface

¹ Please contact the NXP sales and marketing team for order details on HDCP enable parts.

NOTE

The actual feature set depends on the part numbers as described in [Table 2](#). Functions such as display and camera interfaces, and connectivity interfaces, may not be enabled for specific part numbers.

1.1 Block diagram

Figure 1 shows the functional modules in the i.MX 8M Dual / 8M QuadLite / 8M Quad processor system.

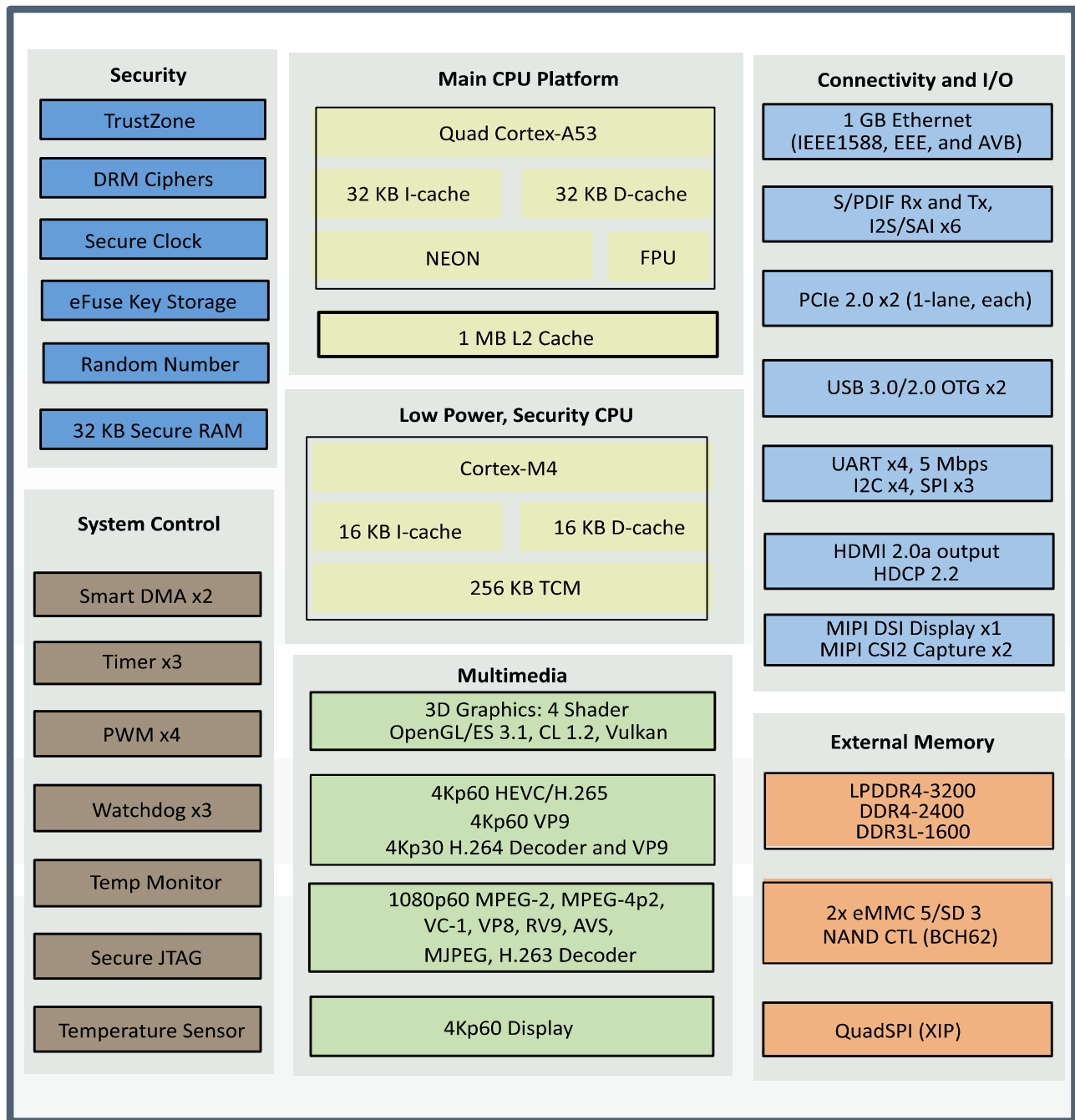

Figure 1. i.MX 8M Dual / 8M QuadLite / 8M Quad system block diagram

1.2 Ordering information

Table 2 shows examples of orderable sample part numbers covered by this data sheet. This table does not include all possible orderable part numbers. If your desired part number is not listed in the table, or you have questions about available parts, contact your NXP representative.

Table 2. Orderable part numbers

Family	Part number	Part differentiator	Cortex-A CPU speed grade	Qualification tier	Temperature T _j (°C)	Package
i.MX 8M Quad	MIMX8MQ6DVAJZAA MIMX8MQ6DVAJZAB	VPU decode, HDR10, GPU, 4x A53	1.5 GHz	Consumer	0 to +95	17 x 17 mm, 0.65 mm pitch, FBGA
i.MX 8M Quad	MIMX8MQ6DVAJZIB	VPU decode, HDR10, GPU, 4x A53, Dolby Digital Plus (DD+) support ¹	1.5 GHz	Consumer	0 to +95	17 x 17 mm, 0.65 mm pitch, FBGA
i.MX 8M Dual	MIMX8MD6DVAJZAA MIMX8MD6DVAJZAB	VPU decode, HDR10, GPU, 2x A53	1.5 GHz	Consumer	0 to +95	17 x 17 mm, 0.65 mm pitch, FBGA
i.MX 8M QuadLite	MIMX8MQ5DVAJZAA MIMX8MQ5DVAJZAB	GPU, No VPU, 4x A53	1.5 GHz	Consumer	0 to +95	17 x 17 mm, 0.65 mm pitch, FBGA

¹ Supply of this Implementation of Dolby technology does not convey a license nor imply a right under any patent, or any other industrial or intellectual property right of Dolby Laboratories, to use this Implementation in any finished end-user or ready-to-use final product. It is hereby notified that a license for such use is required from Dolby Laboratories.

Figure 2 describes the part number nomenclature so that the users can identify the characteristics of the specific part number.

Contact an NXP representative for additional details.

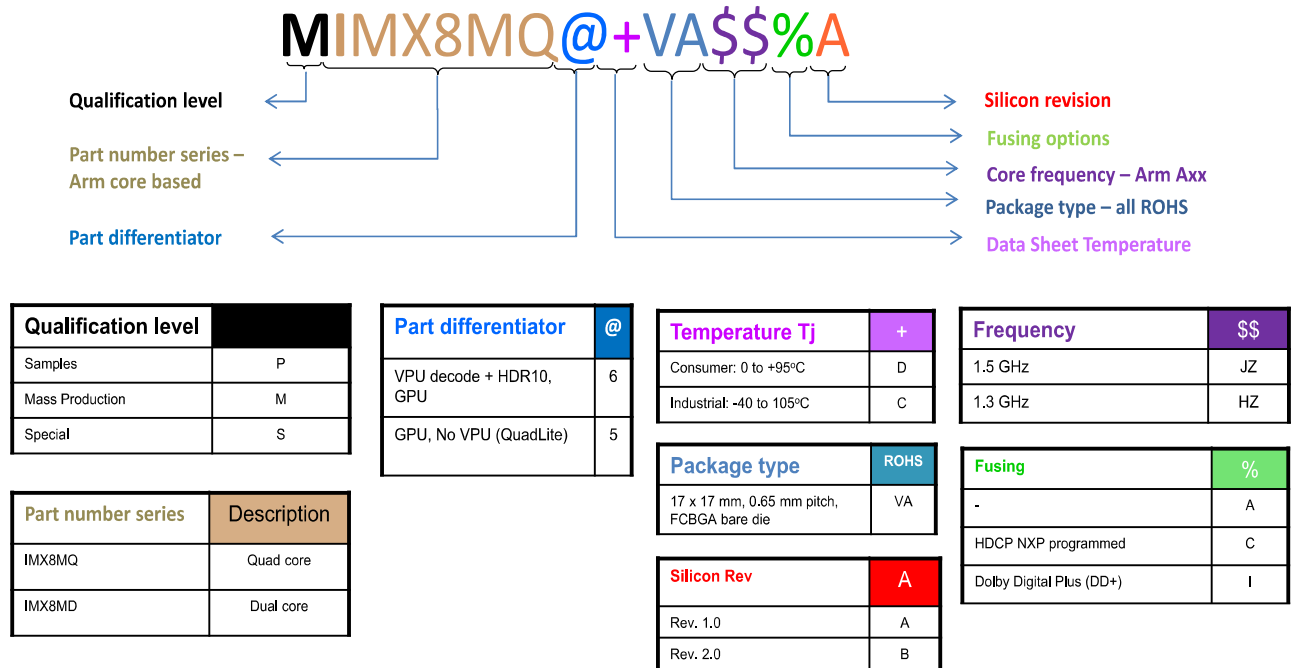

Note 1: Part number with Dolby IP require verification of the Dolby License prior to quoting and prior to shipment. Contact Commercial Marketing.

Figure 2. Part number nomenclature—i.MX 8M Dual / 8M QuadLite / 8M Quad processors

*Please contact the NXP sales and marketing team for order details on HDCP enable parts.

2 Modules list

The i.MX 8M Dual / 8M QuadLite / 8M Quad of processors contain a variety of digital and analog modules. [Table 3](#) describes these modules in alphabetical order.

Table 3. i.MX 8M Dual / 8M QuadLite / 8M Quad modules list

Block mnemonic	Block name	Brief description
APBH-DMA	NAND Flash and BCH ECC DMA Controller	DMA controller used for GPMI2 operation.
Arm	Arm Platform	The Arm Core Platform includes a quad Cortex-A53 core and a Cortex-M4 core. The Cortex-A53 core includes associated sub-blocks, such as the Level 2 Cache Controller, Snoop Control Unit (SCU), General Interrupt Controller (GIC), private timers, watchdog, and CoreSight debug modules. The Cortex-M4 core is used as a customer microcontroller.
BCH	Binary-BCH ECC Processor	The BCH module provides up to 62-bit ECC encryption/decryption for NAND Flash controller (GPMI)
CAAM	Cryptographic accelerator and assurance module	CAAM is a cryptographic accelerator and assurance module. CAAM implements several encryption and hashing functions, a run-time integrity checker, entropy source generator, and a Pseudo Random Number Generator (PRNG). The PRNG is certifiable by the Cryptographic Algorithm Validation Program (CAVP) of the National Institute of Standards and Technology (NIST). CAAM also implements a Secure Memory mechanism. In i.MX 8M Dual / 8M QuadLite / 8M Quad processors, the secure memory provided is 32 KB.
CCM GPC SRC	Clock Control Module, General Power Controller, System Reset Controller	These modules are responsible for clock and reset distribution in the system, and also for the system power management.
CSU	Central Security Unit	The Central Security Unit (CSU) is responsible for setting comprehensive security policy within the i.MX 8M Dual / 8M QuadLite / 8M Quad platform.
CTI-0 CTI-1 CTI-2 CTI-3 CTI-4	Cross Trigger Interface	Cross Trigger Interface (CTI) allows cross-triggering based on inputs from masters attached to CTIs. The CTI module is internal to the Cortex-A53 core platform.
DAP	Debug Access Port	The DAP provides real-time access for the debugger without halting the core to access: <ul style="list-style-type: none"> • System memory and peripheral registers • All debug configuration registers The DAP also provides debugger access to JTAG scan chains.
DC	Display Controller	Dual display controller
DDRC	Double Data Rate Controller	The DDR Controller has the following features: <ul style="list-style-type: none"> • Supports 32/16-bit LPDDR4-3200, DDR4-2400, and DDR3L-1600 • Supports up to 8 Gbyte DDR memory space

Table 3. i.MX 8M Dual / 8M QuadLite / 8M Quad modules list (continued)

Block mnemonic	Block name	Brief description
eCSPI1 eCSPI2 eCSPI3	Configurable SPI	Full-duplex enhanced Synchronous Serial Interface, with data rate up to 52 Mbit/s. Configurable to support Master/Slave modes, only one chip select is supported.
EIM	NOR-Flash / PSRAM interface	The EIM NOR-FLASH / PSRAM provides: <ul style="list-style-type: none"> • Support for 16-bit (in Muxed I/O mode only) PSRAM memories (sync and async operating modes), at slow frequency • Support for 16-bit (in muxed and non muxed I/O modes) NOR-Flash memories, at slow frequency • Multiple chip selects
ENET1	Ethernet Controller	The Ethernet Media Access Controller (MAC) is designed to support 10/100/1000 Mbps Ethernet/IEEE 802.3 networks. An external transceiver interface and transceiver function are required to complete the interface to the media. The module has dedicated hardware to support the IEEE 1588 standard. See the ENET chapter of the <i>i.MX 8M Dual / 8M QuadLite / 8M Quad Applications Processor Reference Manual (IMX8MDQLQRM)</i> for details.
GIC	Generic Interrupt Controller	The GIC handles all interrupts from the various subsystems and is ready for virtualization.
GPIO1 GPIO2 GPIO3 GPIO4 GPIO5	General Purpose I/O Modules	Used for general purpose input/output to external ICs. Each GPIO module supports up to 32 bits of I/O.
GPMI	General Purpose Memory Interface	The GPMI module supports up to 8x NAND devices and 62-bit ECC encryption/decryption for NAND Flash Controller (GPMI2). GPMI supports separate DMA channels for each NAND device.
GPT1 GPT2 GPT3 GPT4 GPT5 GPT6	General Purpose Timer	Each GPT is a 32-bit “free-running” or “set-and-forget” mode timer with programmable prescaler and compare and capture register. A timer counter value can be captured using an external event and can be configured to trigger a capture event on either the leading or trailing edges of an input pulse. When the timer is configured to operate in “set-and-forget” mode, it is capable of providing precise interrupts at regular intervals with minimal processor intervention. The counter has output compare logic to provide the status and interrupt at comparison. This timer can be configured to run either on an external clock or on an internal clock.
GPU3D	Graphics Processing Unit-3D	The GPU3D provides hardware acceleration for 3D graphics algorithms with sufficient processor power to run desktop quality interactive graphics applications on displays.
HDMI Tx	HDMI Tx interface	The HDMI module provides an HDMI standard interface port to an HDMI 2.0a-compliant display.
I2C1 I2C2 I2C3 I2C4	I ² C Interface	I ² C provides serial interface for external devices.

Table 3. i.MX 8M Dual / 8M QuadLite / 8M Quad modules list (continued)

Block mnemonic	Block name	Brief description
IOMUXC	IOMUX Control	This module enables flexible I/O multiplexing. Each IO pad has a default as well as several alternate functions. The alternate functions are software configurable.
LCDIF	LCD interface	The LCDIF is a general purpose display controller used to drive a wide range of display devices varying in size and capability.
MIPI CSI2 (four-lane)	MIPI Camera Serial Interface	This module provides two four-lane MIPI camera serial interfaces, each of them can operate up to a maximum bit rate of 1.5 Gbps.
MIPI DSI (four-lane)	MIPI Display Serial Interface	This module provides a four-lane MIPI display serial interface operating up to a maximum bit rate of 1.5 Gbps.
OCOTP_CTRL	OTP Controller	The On-Chip OTP controller (OCOTP_CTRL) provides an interface for reading, programming, and/or overriding identification and control information stored in on-chip fuse elements. The module supports electrically programmable poly fuses (eFUSES). The OCOTP_CTRL also provides a set of volatile software-accessible signals that can be used for software control of hardware elements, not requiring non volatility. The OCOTP_CTRL provides the primary user-visible mechanism for interfacing with on-chip fuse elements. Among the uses for the fuses are unique chip identifiers, mask revision numbers, cryptographic keys, JTAG secure mode, boot characteristics, and various control signals requiring permanent non volatility.
OCRAM	On-Chip Memory controller	The On-Chip Memory controller (OCRAM) module is designed as an interface between the system's AXI bus and the internal (on-chip) SRAM memory module. In i.MX 8M Dual / 8M QuadLite / 8M Quad processors, the OCRAM is used for controlling the 128 KB multimedia RAM through a 64-bit AXI bus.
PCIe1 PCIe2	2x PCI Express 2.0	The PCIe IP provides PCI Express Gen 2.0 functionality.
PMU	Power Management Unit	Integrated power management unit. Used to provide power to various SoC domains.
PWM1 PWM2 PWM3 PWM4	Pulse Width Modulation	The pulse-width modulator (PWM) has a 16-bit counter and is optimized to generate sound from stored sample audio images. It can also generate tones. It uses 16-bit resolution and a 4x16 data FIFO to generate sound.
QSPI	Quad SPI	The Quad SPI module acts as an interface to external serial flash devices. This module contains the following features: <ul style="list-style-type: none"> • Flexible sequence engine to support various flash vendor devices • Single pad/Dual pad/Quad pad mode of operation • Single Data Rate/Double Data Rate mode of operation • Parallel Flash mode • DMA support • Memory mapped read access to connected flash devices • Multi master access with priority and flexible and configurable buffer for each master

Table 3. i.MX 8M Dual / 8M QuadLite / 8M Quad modules list (continued)

Block mnemonic	Block name	Brief description
SAI1 SAI2 SAI3 SAI4 SAI5 SAI6	Synchronous Audio Interface	The SAI module provides a synchronous audio interface (SAI) that supports full duplex serial interfaces with frame synchronization, such as I2S, AC97, TDM, and codec/DSP interfaces.
SDMA	Smart Direct Memory Access	The SDMA is a multichannel flexible DMA engine. It helps in maximizing system performance by offloading the various cores in dynamic data routing. It has the following features: <ul style="list-style-type: none"> • Powered by a 16-bit Instruction-Set micro-RISC engine • Multi channel DMA supporting up to 32 time-division multiplexed DMA channels • 48 events with total flexibility to trigger any combination of channels • Memory accesses including linear, FIFO, and 2D addressing • Shared peripherals between Arm and SDMA • Very fast Context-Switching with 2-level priority based preemptive multi tasking • DMA units with auto-flush and prefetch capability • Flexible address management for DMA transfers (increment, decrement, and no address changes on source and destination address) • DMA ports can handle unidirectional and bidirectional flows (Copy mode) • Up to 8-word buffer for configurable burst transfers for EMIv2.5 • Support of byte-swapping and CRC calculations • Library of Scripts and API is available
SJC	Secure JTAG Controller	The SJC provides JTAG interface (designed to be compatible with JTAG TAP standards) to internal logic. The i.MX 8M Dual / 8M QuadLite / 8M Quad of processors use JTAG port for production, testing, and system debugging. Additionally, the SJC provides BSR (Boundary Scan Register) standard support and designed to be compatible with IEEE 1149.1. The JTAG port must be accessible during platform initial laboratory bring-up, for manufacturing tests and troubleshooting, as well as for software debugging by authorized entities. The SJC of the i.MX 8M Dual / 8M QuadLite / 8M Quad incorporates three security modes for protecting against unauthorized accesses. Modes are selected through eFUSE configuration.
SNVS	Secure Non-Volatile Storage	Secure Non-Volatile Storage, including Secure Real Time Clock, Security State Machine, and Master Key Control.
SPDIF1 SPDIF2	Sony Philips Digital Interconnect Format	A standard audio file transfer format, developed jointly by the Sony and Phillips corporations. It supports Transmitter and Receiver functionality.
TEMPSENSOR	Temperature Sensor	Temperature sensor
TZASC	Trust-Zone Address Space Controller	The TZASC (TZC-380 by Arm) provides security address region control functions required for intended application. It is used on the path to the DRAM controller.

Table 3. i.MX 8M Dual / 8M QuadLite / 8M Quad modules list (continued)

Block mnemonic	Block name	Brief description
UART1 UART2 UART3 UART4	UART Interface	Each of the UARTv2 modules supports the following serial data transmit/receive protocols and configurations: <ul style="list-style-type: none"> • 7- or 8-bit data words, 1 or 2 stop bits, programmable parity (even, odd, or none) • Programmable baud rates up to 4 Mbps. This is a higher max baud rate relative to the 1.875 MHz, which is stated by the TIA/EIA-232-F standard. • 32-byte FIFO on Tx and 32 half-word FIFO on Rx supporting auto-baud
uSDHC1 uSDHC2	SD/MMC and SDXC Enhanced Multi-Media Card / Secure Digital Host Controller	The i.MX 8M Dual / 8M QuadLite / 8M Quad SoC characteristics: All the MMC/SD/SDIO controller IPs are based on the uSDHC IP. They are designed to support: <ul style="list-style-type: none"> • SD/SDIO standard, up to version 3.0. • MMC standard, up to version 5.0. • 1.8 V and 3.3 V operation, but do not support 1.2 V operation. • 1-bit/4-bit SD and SDIO modes, 1-bit/4-bit/8-bit MMC mode. One uSDHC controller (SD1) can support up to an 8-bit interface, the other controller (SD2) can only support up to a 4-bit interface.
USB 3.0/2.0	2x USB 3.0/2.0 controllers and PHYs	Two USB controllers and PHYs that support USB 3.0 and USB 2.0. Each USB instance contains: <ul style="list-style-type: none"> • USB 3.0 core, which can operate in both 3.0 and 2.0 mode
VPU	Video Processing Unit	A high performing video processing unit (VPU), which covers many SD-level and HD-level video decoders. See the <i>i.MX 8M Dual / 8M QuadLite / 8M Quad Applications Processor Reference Manual (IMX8MDQLQRM)</i> for a complete list of the VPU's decoding and encoding capabilities.
WDOG1 WDOG2 WDOG3	Watchdog	The watchdog (WDOG) timer supports two comparison points during each counting period. Each of the comparison points is configurable to evoke an interrupt to the Arm core, and a second point evokes an external event on the WDOG line.
XTALOSC	Crystal Oscillator interface	The XTALOSC module enables connectivity to an external crystal oscillator device.

2.1 Recommended connections for unused interfaces

The recommended connections for unused analog interfaces can be found in the Section, “Unused Input/Output Terminations,” in the hardware development guide for the device.

3 Electrical characteristics

This section provides the device and module-level electrical characteristics for the i.MX 8M Dual / 8M QuadLite / 8M Quad processors.

3.1 Chip-level conditions

This section provides the device-level electrical characteristics for the IC. See [Table 4](#) for a quick reference to the individual tables and sections.

Table 4. i.MX 8M Dual / 8M QuadLite / 8M Quad chip-level conditions

For these characteristics, ...	Topic appears ...
Absolute maximum ratings	on page 13
FPBGA package thermal resistance	on page 15
Operating ranges	on page 18
External clock sources	on page 21
Maximum supply currents	on page 21
Power modes	on page 23
USB PHY Suspend current consumption	on page 25

3.1.1 Absolute maximum ratings

CAUTION

Stresses beyond those listed under [Table 5](#) may affect reliability or cause permanent damage to the device. These are stress ratings only. Functional operation of the device at these or any other conditions beyond those indicated in the operating ranges or parameters tables is not implied.

Table 5. Absolute maximum ratings

Parameter description	Symbol	Min	Max	Unit	Notes
Core supply voltages	VDD_ARM VDD_SOC	-0.3	1.1	V	1.1 V is for VDD_ARM overdrive
Power supply for GPU	VDD_GPU	-0.3	1.1	V	1.1 V is for overdrive
Power supply for VPU	VDD_VPU	-0.3	1.1	V	Nominal mode
		-0.3	1.1	V	Overdrive mode
Core voltage	VDD_DRAM	-0.3	1.05	V	—
DDR I/O supply voltage	NVCC_DRAM	-0.3	1.42	V	—

Electrical characteristics

Table 5. Absolute maximum ratings (continued)

Parameter description	Symbol	Min	Max	Unit	Notes
Power supply for analog domain	VDDA_1P8	-0.3	1.98	V	—
GPIO supply voltage	NVCC_JTAG, NVCCGPIO1, NVCC_ENT, NVCC_SD1, NVCC_SD2, NVCC_NAND, NVCC_SAI1, NVCC_SAI2, NVCC_SAI3, NVCC_SAI5, NVCC_ECSPi, NVCC_I2C, NVCC_UART	-0.3	3.6	V	1.8 V mode/3.3 V mode
SNVS IO supply voltage	NVCC_SNVS	-0.3	3.6	V	3.3 V mode only
VDD_SNVS supply voltage	VDD_SNVS	-0.3	0.99	V	—
PLL 1.8 V supply voltage	VDDA_DRAM	-0.3	1.89	V	—
Supply for 25 MHz crystal	VDDA_1P8_XTAL_25M	-0.3	1.98	V	—
Supply for 27 MHz crystal	VDDA_1P8_XTAL_27M	-0.3	1.98	V	—
HDMI supply voltage	HDMI_AVDDCLK	-0.3	0.99		—
	HDMI_AVDDIO	-0.3	1.90		—
	HDMI_AVDDCORE	-0.3	0.99		—
PCIe PHY supply voltage	PCIE_VP	-0.3	0.99	V	—
	PCIE_VPH	-0.3	3.63	V	—
	PCIE_VPTX	-0.3	0.99	V	—
MIPI supply voltage	MIPI_VDDA	-0.3	1.1	V	—
	MIPI_VDDHA	-0.3	1.98	V	—
	MIPI_VDD	-0.3	1.1	V	—
	MIPI_VDDPLL	-0.3	1.1	V	—
USB high supply voltage	USB1_VDD33, USB1_VPH, USB2_VDD33, USB2_VPH	-0.3	3.63	V	—
USB_VBUS input detected	USB1_VBUS, USB2_VBUS	-0.3	5.25	V	—
Input voltage on USB*_DP, USB*_DN pins	USB1_DP/USB1_DN, USB2_DP/USB2_DN	-0.3	USB1_VDD33, USB2_VDD33	V	—
Temperature sensor	VDD_1P8_TSENSOR	-0.3	1.98	V	—
Fuse power	EFUSE_VQPS	-0.3	1.98	V	—
Input/output voltage range	V_{in}/V_{out}	-0.3	OVDD ¹ +0.3	V	—
Storage temperature range	T _{STORAGE}	-40	150	°C	—

¹ OVDD is the I/O supply voltage.

Table 6. Electrostatic discharge and latch up ratings

Parameter description		Rating	Reference	Comment
Electrostatic Discharge (ESD)	Human Body Model (HBM)	±1000 V	JS-001-2017	—
	Charged Device Model (CDM)	±250 V	JS-002-2018	—
Latch UP (LU)	Immunity level: <ul style="list-style-type: none"> • Class I @ 25 °C ambient temperature • Class II @ 105 °C ambient temperature 	A A	JESD78E	—

3.1.2 Thermal resistance

3.1.2.1 FPBGA package thermal resistance

Table 7 displays the thermal resistance data.

Table 7. Thermal resistance data

Rating	Test conditions	Symbol	17 x 17 pkg value	Unit
Junction to Ambient ¹	Single-layer board (1s); natural convection ²	$R_{\theta JA}$	Bare die: 16.4	°C/W
	Four-layer board (2s2p); natural convection ²	$R_{\theta JA}$		°C/W
Junction to Ambient ¹	Single-layer board (1s); airflow 200 ft/min ^{2,3}	$R_{\theta JA}$	Bare die: 13.9	°C/W
	Four-layer board (2s2p); airflow 200 ft/min ^{2,3}	$R_{\theta JA}$		°C/W
Junction to Board ^{1,4}	—	$R_{\theta JB}$	Bare die: 4.6	°C/W
Junction to Case ^{1,5}	—	$R_{\theta JC}$	Bare die: 0.1	°C/W

¹ Junction temperature is a function of die size, on-chip power dissipation, package thermal resistance, mounting site (board) temperature, ambient temperature, air flow, power dissipation of other components on the board, and board thermal resistance.

² Per JEDEC JESD51-2 with the single layer board horizontal. Thermal test board meets JEDEC specification for the specified package.

³ Per JEDEC JESD51-6 with the board horizontal.

⁴ Thermal resistance between the die and the printed circuit board per JEDEC JESD51-8. Board temperature is measured on the top surface of the board near the package.

⁵ Thermal resistance between the die and the case top surface as measured by the cold plate method (MIL SPEC-883 Method 1012.1).

3.1.3 Power architecture

The power architecture of the chip is defined based on the assumption that PMIC is always used to supply all the power rails to the processor.

The digital logic inside chip will be supplied with four supplies: VDD_ARM, VDD_GPU, VDD_VPU, and VDD_SOC. They are expected to be directly supplied externally through power pads. The ARM supply is separated with SoC because ARM A53 platform need to support DVFS, e.g., ARM requires 1.0

Electrical characteristics

V overdrive to run at 1.4 GHz. For any application that only runs ARM core below 1.2 GHz, VDD_ARM and VDD_SOC power rails can be connected together and supplied with 0.9 V. VPU/GPU supply is separated with SoC because VPU/GPU might need overdrive to support higher frame rate.

The GPIO pads will have external power supply for 3.3 V and 1.8 V IO voltage. The IO pad core voltage will be supplied directly by VDD_SOC.

The DRAM controller and PHY have three external power supplies: 0.9 V/1.0 V for controller and PHY digital logic, 1.8 V for PHY analog circuit, and 1.1/1.2/1.35 V for I/O. The DRAM pads will also have VREF supply which is always $\frac{1}{2}$ of the NVCC_DRAM. The two DRAM channels will have all their power rails separated, this allows one of the channel to be fully power down when only single channel is used in the application.

For all the integrated analog modules, their 1.8 V power will be supplied externally through power pads. This supply is separated with other power pads to keep them clean.

For all the integrated PCIe PHY, HDMI PHY, MIPI PHY, and USB PHY, their 3.3 V, 1.8 V, and 0.9 V power will be supplied externally through power pads. The powers to those PHYs can be shared to reduce the number of power supplies from the PMIC.

For SNVS/RTC, both the 0.9 V core logic supply and 3.3 V I/O pad supply will also be supplied directly from the PMIC. If the PMIC does not have 0.9 V output, an external LDO can be used to generate the 0.9 V supply from 3.3 V.

There are no integrated LDOs inside the chip.

[Figure 3](#) is the power architecture diagram for the whole chip.

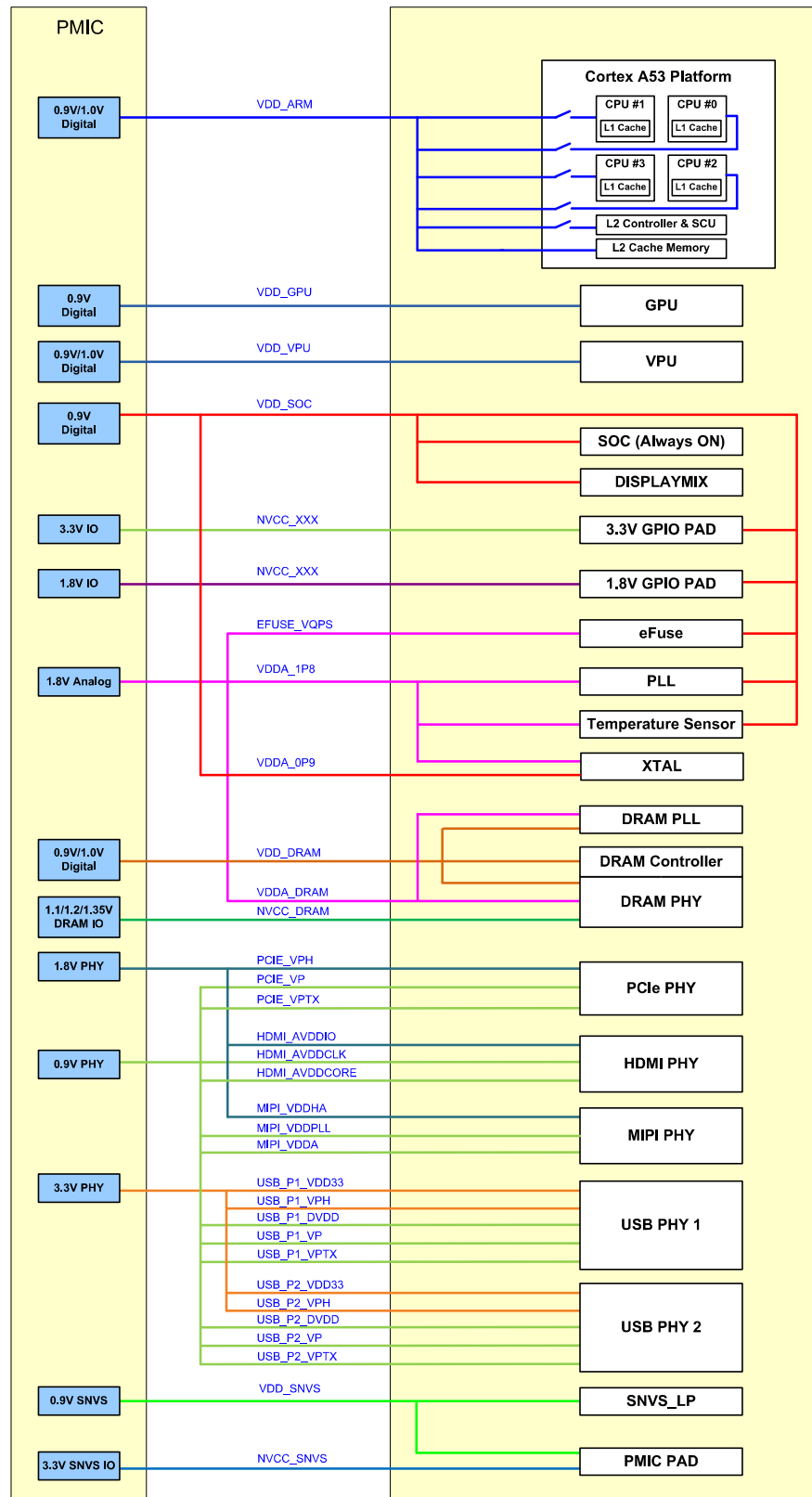

Figure 3. Power architecture

3.1.4 Operating ranges

Table 8 provides the operating ranges of the i.MX 8M Dual / 8M QuadLite / 8M Quad processors. For details on the chip's power structure, see the “Power Management Unit (PMU)” chapter of the *i.MX 8M Dual / 8M QuadLite / 8M Quad Applications Processor Reference Manual (IMX8MDQLQRM)*.

Table 8. Operating ranges

Parameter description	Symbol	Min	Typ	Max ¹	Unit	Comment
Power supply for Quad-A53	VDD_ARM	0.81	0.9	1.05	V	Nominal mode—the maximum Arm core frequency supported in this mode is 1000 MHz.
		0.9	1.0	1.05	V	Overdrive mode—the maximum Arm core frequency supported in this mode is defined in Table 2.
Power supply for SoC logic	VDD_SOC	0.81	0.9	0.99	V	—
Power supply for GPU	VDD_GPU	0.81	0.9	1.05	V	Nominal mode—the maximum GPU frequency supported in this mode is 800 MHz.
		0.9	1.0	1.05	V	Overdrive mode—the maximum GPU frequency supported in this mode is 1 GHz.
Power supply for VPU	VDD_VPU	0.81	0.9	1.05	V	Nominal mode—the maximum VPU frequency supported in this mode is 550/500/588 MHz.
		0.9	1.0	1.05	V	Overdrive mode—the maximum VPU G2/G1/AXI Bus frequency supported in this mode is 660/600/800 MHz.
Core voltage	VDD_DRAM	0.81	0.9	1.05	V	Nominal mode—the maximum DRAM working frequency supported in this mode is 933 MHz.
		0.99	1.0	1.05	V	Overdrive mode—the maximum DRAM working frequency supported in this mode is 1600 MHz
Power Supply Analog Domain	VDDA_1P8	1.62	1.8	1.98	V	Power for internal analog blocks—must match the range of voltages that the rechargeable backup battery supports.
PLL 1.8 V supply voltage	VDDA_DRAM	1.71	1.8	1.89	V	—
Backup battery supply range	VDD_SNVS	0.81	0.9	0.99	V	—

Table 8. Operating ranges (continued)

Parameter description	Symbol	Min	Typ	Max ¹	Unit	Comment
Supply for 25 MHz crystal	VDD_1P8_XTAL_25M	1.6	1.8	1.98	V	—
Supply for 27 MHz crystal	VDD_1P8_XTAL_27M	1.6	1.8	1.98	V	—
Temperature sensor	VDD_1P8_TSENSOR	1.6	1.8	1.98	V	—
USB supply voltages	USB1_VDD33/ USB1_VPH	3.069	3.3	3.63	V	This rail is for USB
	USB2_VDD33/ USB2_VPH	3.069	3.3	3.63	V	This rail is for USB
	USB1/2_DVDD	0.837	0.900	0.990	V	0.9 V supply for USB high speed operation
	USB1/2_VP	0.837	0.900	0.990	V	0.9 V supply for USB super speed operation
	USB1/2_VPTX	0.837	0.900	0.990	V	0.9 V supply for PHY transmit
	USB1_VBUS/ USB2_VBUS	0.8	1.4	5.25	V	—
DDR I/O supply voltage	NVCC_DRAM	1.06	1.10	1.17	V	LPDDR4
		1.14	1.2	1.26	V	DDR4
		1.28	1.35	1.42	V	DDR3L
	DRAM_VREF	0.49 x NVCC_D RAM	0.5 x NVCC_D RAM	0.51 x NVCC_D RAM	V	Set to one-half NVCC_DRAM
GPIO supply voltages	NVCC_JTAG, NVCC_SD1, NVCC_SD2, NVCC_NAND, NVCC_SAI1, NVCC_SAI2, NVCC_SAI3, NVCC_SAI5, NVCC_ECSP1, NVCC_I2C, NVCC_UART	1.65, 3.0	1.8, 3.3	1.95, 3.6	V	—
	NVCC_ENET	1.65, 2.25 3.0	1.8, 2.5 3.3	1.95, 2.75 3.6	V	—
	NVCC_GPIO1	1.65 3.0	1.8, 3.3	1.95, 3.6	V	Power for GPIO1_IO00 ~ GPIO1_IO15
	NVCC_SNV5	3.0	3.3	3.6	V	Power for 3.3 V only

Table 8. Operating ranges (continued)

Parameter description	Symbol	Min	Typ	Max ¹	Unit	Comment
HDMI supply voltage	HDMI_AVDDCLK	0.850	0.900	0.990	V	0.9 V supply for HDMI high speed clock
	HDMI_AVDDIO	1.700	1.800	1.900	V	1.8 V supply for HDMI bias and PLL
	HDMI_AVDDCORE	0.850	0.900	0.990	V	0.9 V supply for HDMI analog
MIPI supply voltage	MIPI_VDDA	0.81	0.9/1.0	1.1	V	Analog core power supply
	MIPI_VDDHA	1.62	1.8	1.98	V	Analog IO power supply
	MIPI_VDD	0.81	0.9/1.0	1.1	V	Digital core power supply
	MIPI_VDDPLL	0.81	0.9/1.0	1.1	V	Analog supply for MIPI PLL
Voltage rails supplied for 1.8 V PHY	PCIE_VPH	1.674	1.8	1.98	V	Set PCIE1/2_VREG_BYPASS = 1 to bypass internal regulator
		3.069	3.3	3.63	V	Set PCIE1/2_VREG_BYPASS = 0 to use internal regulator
	PCIE_VP, PCIE_VPTX	0.837	0.9	0.99	V	Supplied from PMIC
Temperature sensor accuracy ²	T _{delta}	—	±3	—	°C	Typical accuracy over the range 0°C to 95°C
Fuse power	EFUSE_VQPS	1.71	1.8	1.98	V	Power supply for internal use
Junction temperature, consumer	T _J	0	—	+95	°C	See Table 2 for complete list of junction temperature capabilities.

¹ Applying the maximum voltage results in maximum power consumption and heat generation. A voltage set point = (V_{min} + the supply tolerance) is recommended. This result in an optimized power/speed ratio.

² For consumer products, the operating range (including system boot) of temperature sensor is from 0°C to 95°C. Otherwise, it may cause a misleading out-of-range indication.

3.1.5 External clock sources

A 25 MHz oscillator is used as the primary clock source for the PLLs to generate the clock for CPU, BUS, and high-speed interfaces. For fractional PLLs, the 25 MHz clock from the oscillator can be directly used as the PLL reference clock.

A 27 MHz oscillator is used as the reference clock for HDMI PHY. Also it can be used as the alternative source for the fractional PLLs.

A 32 kHz clock input pin is used as the RTC clock source. It is expected to be supplied by an external 32.768 kHz oscillator.

Two pairs of differential clock inputs, named as CLK1P and CLK1N, can be used as the reference clock for the PLL. This is mainly used for a high-speed clock input during testing.

Four clock inputs to the CCM from normal GPIO pads via IOMUX can be used as the clock sources in the CCM.

Table 9 shows the interface frequency requirements.

Table 9. External input clock frequency

Parameter description	Symbol	Min	Typ	Max	Unit
RTC ^{1,2}	f_{ckil}	—	32.768 ³	—	kHz
XTALI_25M/XTALO_25M ²	f_{xtal}	20	25	40	MHz
XTALI_27M/XTALO_27M ²	f_{xtal}	20	27	40	MHz

¹ External oscillator or a crystal with internal oscillator amplifier.

² The required frequency stability of this clock source is application dependent.

³ Recommended nominal frequency 32.768 kHz.

The typical values shown in Table 9 are required for use with NXP BSPs to ensure precise time keeping and USB operation. For RTC operation, two clock sources are available. The decision of choosing a clock source should be made based on real-time clock use and precision timeout.

3.1.6 Maximum supply currents

Power consumption is highly dependent on the application. Estimating the maximum supply currents required for power supply design is difficult because the use cases that requires maximum supply current is not a realistic use cases.

To help illustrate the effect of the application on power consumption, data was collected while running consumer standard benchmarks that are designed to be compute and graphic intensive. The results provided are intended to be used as guidelines for power supply design.

Table 10. Maximum supply currents¹

Power rail	Max current	Unit
VDD_ARM	384 to 2410 ¹	mA
VDD_SOC	1400 to 1870 ¹	mA
VDD_GPU	0 to 2040 ¹	mA
VDD_VPU	0 to 610 ¹	mA
VDD_DRAM	600 to 870 ¹	mA
VDDA_0P9	50	mA
VDDA_1P8	20	mA
VDDA_DRAM	30	mA
VDD_SNVS	5	mA
NVCC_SNVS	5	mA

Electrical characteristics

Table 10. Maximum supply currents¹ (continued)

Power rail	Max current	Unit
NVCC_<XXX>	$I_{max} = N \times C \times V \times (0.5 \times F)$ Where: N—Number of IO pins supplied by the power line C—Equivalent external capacitive load V—IO voltage (0.5 x F)—Data change rate. Up to 0.5 of the clock rate (F). In this equation, I_{max} is in Amps, C in Farads, V in Volts, and F in Hertz.	
NVCC_DRAM	375 to 750 ¹	mA
DRAM_VFEF	10	mA
USB1_DVDD	9.2	mA
USB2_DVDD	9.2	mA
USB1_VP	35.7	mA
USB2_VP	35.7	mA
USB1_VPTX	21.2	mA
USB2_VPTX	21.2	mA
USB1_VDD33	24.5	mA
USB2_VDD33	24.5	mA
USB1_VPH	20.3	mA
USB2_VPH	20.3	mA
PCIE_VP (PCIE1)	38.1	mA
PCIE_VP (PCIE2)	38.1	mA
PCIE_VPH (PCIE1)	43	mA
PCIE_VPH (PCIE2)	43	mA
PCIE_VPTX (PCIE1)	14.3	mA
PCIE_VPTX (PCIE2)	14.3	mA
HDMI_AVDDCLK	95.89	mA
HDMI_AVDDCORE		
HDMI_AVDDIO	6.551	mA
MIPI_VDDA (DSI)	17.1	mA
MIPI_VDDHA (DSI)	4.2	mA
MIPI_VDD (DSI)	14.4	mA
MIPI_VDDPLL (DSI)	3.8	mA
MIPI_VDDA (CSI1/2)	18.79	mA

Table 10. Maximum supply currents¹ (continued)

Power rail	Max current	Unit
MIPI_VDDHA (CSI1/2)	2.97	mA
EFUSE_VQPS	96.35	mA

¹ Use case dependent

3.1.7 Power modes

The i.MX 8M Dual / 8M QuadLite / 8M Quad processors support the following power modes:

- **RUN Mode:** All external power rails are on, CPU is active and running; other internal modules can be on/off based on application.
- **IDLE Mode:** When there is no thread running and all high-speed devices are not active, the CPU can automatically enter this mode. The CPU can be in the power-gated state but with L2 data retained, DRAM and the bus clock are reduced. Most of the internal logic is clock gated but still remains powered. The M4 core can remain running. Compared with RUN mode, all the external power rails from the PMIC remain the same, and most of the modules still remain in their state.
- **Deep Sleep Mode (DSM):** The most efficient power saving mode where all the clocks are off and all the unnecessary power supplies are off.
- **SNVS Mode:** This mode is also called RTC mode. Only the power for the SNVS domain remains on to keep RTC and SNVS logic alive.
- **OFF Mode:** All power rails are off.

Table 11. Chip power in different LP mode

Mode	Supply	Max. ¹	Unit
SNVS	VDD_SNVS (1.0 V)	1.39	mA
	NVCC_SNVS (3.6 V)	4.25	
	Total ²	17	mW
Deep Sleep Mode (DSM)	VDD_SOC (1.0 V)	148.50	mA
	VDDA_1P8 (2.0 V)	12.82	
	VDDA_0P9 (1.0 V)	0.30	
	VDDA_DRAM (1.8 V)	0.50	
	VDD_SNVS (1.0 V)	0.25	
	NVCC_SNVS (3.3 V)	4.80	
	NVCC_DRAM (1.17 V)	4.51	
	Total ²	197	mW

Table 11. Chip power in different LP mode (continued)

Mode	Supply	Max. ¹	Unit
IDLE	VDD_ARM (1.0 V)	152.10	mA
	VDD_SOC (1.0 V)	132.90	
	VDD_DRAM (1.0 V)	44.10	
	VDDA_1P8 (2.0 V)	13.53	
	VDDA_0P9 (1.0 V)	0.30	
	VDDA_DRAM (1.8 V)	1.32	
	VDD_SNVS (1.0 V)	0.25	
	NVCC_SNVS (3.3 V)	4.34	
	NVCC_DRAM (1.17 V)	13.12	
	Total ²	389	mW
RUN	Total	1 to 4	W

¹ All the power numbers defined in the table are based on typical silicon at 25°C. Use case dependent

² Sum of the listed supply rails.

Table 12 summarizes the external power supply states in all the power modes.

Table 12. The power supply states

Power rail	OFF	SNVS	SUSPEND	IDLE	RUN
VDD_ARM	OFF	OFF	OFF	ON	ON
VDD_SOC	OFF	OFF	ON	ON	ON
VDD_GPU	OFF	OFF	OFF	OFF	ON/OFF
VDD_VPU	OFF	OFF	OFF	OFF	ON/OFF
VDD_DRAM	OFF	OFF	OFF	ON	ON
VDDA_0P9	OFF	OFF	ON	ON	ON
VDDA_1P8	OFF	OFF	ON	ON	ON
VDDA_DRAM	OFF	OFF	ON	ON	ON
VDD_SNVS	OFF	ON	ON	ON	ON
NVCC_SNVS	OFF	ON	ON	ON	ON
NVCC_<XXX>	OFF	OFF	ON	ON	ON
NVCC_DRAM	OFF	OFF	ON	ON	ON
DRAM_VREF	OFF	OFF	OFF	ON	ON

3.1.8 USB PHY Suspend current consumption

3.1.8.1 Low power Suspend Mode

The VBUS Valid comparators and their associated bandgap circuits are enabled by default. [Table 13](#) shows the USB interface current consumption in Suspend mode with default settings.

Table 13. USB PHY current consumption in Suspend mode¹

	USB1_VDD33	USB2_VDD33
Current	154 μ A	154 μ A

¹ Low Power Suspend is enabled by setting USBx_PORTSC1 [PHCD]=1 [Clock Disable (PLPSCD)].

3.1.8.2 Power-Down modes

[Table 14](#) shows the USB interface current consumption with only the OTG block powered down.

Table 14. USB PHY current consumption in Sleep mode¹

	USB1_VDD33	USB2_VDD33
Current	520 μ A	520 μ A

¹ VBUS Valid comparators can be disabled through software by setting USBNC_OTG*_PHY_CFG2[OTGDISABLE0] to 1. This signal powers down only the VBUS Valid comparator, and does not control power to the Session Valid Comparator, ADP Probe and Sense comparators, or ID detection circuitry.

In Power-Down mode, everything is powered down, including the USB_VBUS valid comparators and their associated bandgap circuitry in typical condition. [Table 15](#) shows the USB interface current consumption in Power-Down mode.

Table 15. USB PHY current consumption in Power-Down mode¹

	USB1_VDD33	USB2_VDD33
Current	146 μ A	146 μ A

¹ The VBUS Valid Comparators and their associated bandgap circuits can be disabled through software by setting USBNC_OTG*_PHY_CFG2[OTGDISABLE0] to 1 and USBNC_OTG*_PHY_CFG2[DRVVBUS0] to 0, respectively.

3.1.9 PCIe PHY 2.1 DC electrical characteristics

Table 16. PCIe recommended operating conditions

Parameter	Description	Min	Max	Unit
PCIE_VP	Low Power Supply Voltage for PHY Core	—	0.837	V
PCIE_VPTX	PHY transmit supply	—	0.837	
PCIE_VPH	High Power Supply Voltage for PHY Core	1.8	1.674	
		3.3	3.069	

Electrical characteristics

Table 16. PCIe recommended operating conditions (continued)

Parameter	Description	Min	Max	Unit
T _A	Commercial Temperature Range	0	70	°C
T _J	Simulation Junction Temperature Range	-40	125	°C

Note: V_{DD} should have no more than 40 mVpp AC power supply noise superimposed on the high power supply voltage for the PHY core (1.8 V nominal DC value). At the same time, VDD should have no more than 20 mVpp AC power supply noise superimposed on the low power supply voltage for the PHY core (1.0 V nominal value or 1.1 V overdrive DC value). The power supply voltage variation for the PHY core should have less than ±5% including the board-level power supply variation and on-chip power supply variation due to the finite impedances in the package.

Table 17. PCIe DC electrical characteristics

Parameter	Description	Min	Typ	Max	Unit	
PCIE1_VP, PCIE2_VP	Power Supply Voltage	0.9 - 7%	0.9	0.9 + 10%	V	
PD	Power Consumption	Normal	—	40	—	mW
		Partial Mode	—	27	—	mW
		Slumber Mode	—	7	—	mW
		Full Powerdown	—	0.2	—	mW

Table 18. PCIe PHY high-speed characteristics

High Speed I/O Characteristics						
Description	Symbol	Speed	Min.	Typ.	Max.	Unit
Unit Interval	UI	2.5 Gbps	—	400	—	ps
		5.0 Gbps	—	200	—	
TX Serial output rise time (20% to 80%)	T _{TXRISE}	2.5 Gbps	100	—	—	ps
		5.0 Gbps	100	—	—	
TX Serial output fall time (80% to 20%)	T _{TXFALL}	2.5 Gbps	100	—	—	ps
		5.0 Gbps	100	—	—	
TX Serial data output voltage (Differential, pk-pk)	ΔV _{TX}	2.5 Gbps	800	—	1100	mVp-p
		5.0 Gbps	600	—	900	
PCIe Tx deterministic jitter < 1.5 MHz	TRJ	2.5 Gbps	3	—	—	ps, rms
		5.0 Gbps	3	—	—	
PCIe Tx deterministic jitter > 1.5 MHz	TDJ	2.5 Gbps	—	—	20	ps, pk-pk
		5.0 Gbps	—	—	10	

Table 18. PCIe PHY high-speed characteristics (continued)

High Speed I/O Characteristics						
Description	Symbol	Speed	Min.	Typ.	Max.	Unit
RX Serial data input voltage (Differential pk-pk)	ΔV_{RX}	2.5 Gbps	120	—	1200	mVp-p
		5.0 Gbps	120	—	1200	

Table 19. PCIe PHY reference clock timing requirements (vp is PIE_VP, 0.9 V power supply)

Symbol	Parameter	Min.	Typ.	Max.	Unit	Condition
FREF_OFFSET	Reference clock frequency offset	-300	—	30	ppm	—
DJREF_CLK	Reference clock cycle to cycle jitter	—	—	35	ps	DJ across all frequencies
DCREF_CLK	Duty cycle	40	—	60	%	—
VCMREF_CLK	Common mode input level	0	—	vp	V	Differential inputs
VDREF_CLK	Differential input swing	-0.3	—	—	V _{PP}	Differential inputs
VOLREF_CLK	Single-ended input logic low	-0.3	—	-0.3	V	If single-ended input is used.
VOHREF_CLK	Single-ended input logic high	vp - 0.3	—	vp + 0.3	V	If single-ended input is used.
SWREF_CLK	Input edge rate	—	—	—	V/ns	—
REF_CLK_SKEW	Reference clock skew (\pm)	—	—	200	ps	—

PCIe PHY interface is compliant with PCIe Express GEN2.

3.2 Power supplies requirements and restrictions

The system design must comply with power-up sequence, power-down sequence, and steady state guidelines as described in this section to guarantee the reliable operation of the device. Any deviation from these sequences may result in the following situations:

- Excessive current during power-up phase
- Prevention of the device from booting
- Irreversible damage to the processor (worst-case scenario)

3.2.1 Power-up sequence

The i.MX 8M Dual / 8M QuadLite / 8M Quad processors have the following power-up sequence requirements:

- Turn on NVCC_SNVS
- Turn on VDD_SNVS
- RTC_RESET_B release (after 32K clock stable and before POR_B release, no constraint with any other power supplies)

Electrical characteristics

- Turn on VDD_SOC and VDDA_0P9
- Turn on VDD_ARM, VDD_GPU, VDD_VPU, and VDD_DRAM (no sequence between these four rails)
- Turn on VDDA_1P8_XXX, VDDA_DRAM (no sequence between these rails)
- Turn on NVCC_XXX and NVCC_DRAM (no sequence between these rails)
- POR_B release (it should be asserted during the entire power up sequence)

If the GPU/VPU is not used during the ROM boot sequence, VDD_GPU/VDD_VPU can stay off to reduce the power during boot, and then turned on by software afterwards.

During the chip power up, the power of the PCIe PHY, USB PHY, HDMI PHY, and MIPI PHY could stay off. After chip power up, the power of these PHYs should be turned on. If any of the PHY power are turned on during the power up sequence, the POR_B can be released after the PHY power is stable.

3.2.2 Power-down sequence

The i.MX 8M Dual / 8M QuadLite / 8M Quad processors have the following power-down sequence requirements:

- Turn off NVCC_SNVS and VDD_SNVS last
- Turn off VDD_SOC after the other power rails or at the same time as other rails
- No sequence for other power rails during power down

3.2.3 Power supplies usage

I/O pins should not be externally driven while the I/O power supply for the pin (NVCC_XXX) is OFF. This can cause internal latch-up and malfunctions due to reverse current flows. For information about the I/O power supply of each pin, see “Power Rail” columns in the pin list tables of [Section 5, Package information and contact assignments.](#)”

[Table 20](#) lists the modules in each power domain.

Table 20. The modules in the power domains

Power Domain	Modules in the domain
VDD_ARM	Arm A53
VDD_GPU	GC7000L GPU
VDD_VPU	G1 and G2 VPU
VDD_DRAM	DRAM controller and PHY
VDD_SNVS	SNVS_LP
VDD_SOC	All the other modules

3.3 PLL electrical characteristics

Table 21. PLL electrical parameters

PLL type	Parameter	Value
AUDIO_PLL1	Clock output range	650 MHz ~ 1.3 GHz
	Reference clock	25 MHz
	Lock time	50 μ s
	Jitter	$\pm 1\%$ of output period, ≥ 50 ps
AUDIO_PLL2	Clock output range	650 MHz ~ 1.3 GHz
	Reference clock	25 MHz
	Lock time	50 μ s
	Jitter	$\pm 1\%$ of output period, ≥ 50 ps
VIDEO_PLL1	Clock output range	650 MHz ~ 1.3 GHz
	Reference clock	25 MHz
	Lock time	50 μ s
VIDEO_PLL2	Clock output range	650 MHz ~ 1.3 GHz
	Reference clock	25 MHz
	Lock time	70 μ s
SYS_PLL1	Clock output range	800 MHz
	Reference clock	25 MHz
	Lock time	70 μ s
SYS_PLL2	Clock output range	1 GHz
	Reference clock	25 MHz
	Lock time	70 μ s
SYS_PLL3	Clock output range	600 MHz ~ 1GHz
	Reference clock	25 MHz
	Lock time	70 μ s
ARM_PLL	Clock output range	800 MHz ~ 1.6 GHz
	Reference clock	25 MHz
	Lock time	50 μ s
DRAM_PLL	Clock output range	400 MHz–800 MHz
	Reference clock	25 MHz
	Lock time	70 μ s

Table 21. PLL electrical parameters (continued)

PLL type	Parameter	Value
GPU_PLL	Clock output range	800 MHz ~1.6 GHz
	Reference clock	25 MHz
	Lock time	50 μ s
VPU_PLL	Clock output range	400 MHz ~ 800 MHz
	Reference clock	25 MHz
	Lock time	50 μ s

3.4 On-chip oscillators

3.4.1 OSC25M and OSC27M

A 25 MHz oscillator is used as the primary clock source for the PLLs to generate the clock for the CPU, BUS, and high-speed interfaces. For fractional PLLs, the 25 MHz clock from the oscillator can be used as the PLL reference clock directly.

A 27 MHz oscillator is used as the reference clock for HDMI PHY. It can also be used as the alternative source for the fractional PLLs.

Table 22 lists the electrical specifications of this oscillator when loaded with an NX5032GA 40 MHz crystal unit at 40 MHz frequency. All values are valid only for the device TJ operating specification of -40 °C to 125 °C.

Table 22. Electrical specification of oscillator @ 1.8 V

Parameter	Min	Typ	Max	Unit
Voltage swing on external pin ¹	250	—	800	mV
Power consumption (analog supply RMS current in OSC mode) ^{2, 3}	—	—	4	mA
Start-up time ^{1, 2}	—	—	2	ms

¹ The start-up time is dependent upon crystal characteristics, board leakage, etc.; high ESR and excessive capacitive loads can cause long start-up time.

² Electrical parameters are subject to change.

³ Maximum current is observed during startup. After oscillation is stable, the current from HV supply comes down.

Table 23 shows the transconductance specification of the oscillator (in mA/V).

Table 23. Transconductance specification of oscillator

GM_sel	Min	Max
111	10	25

Table 24 shows the input clock specifications.

Table 24. Input clock specification

Parameter	Min	Typ	Max	Unit
Clock Frequency in OSC mode	20	—	40	MHz
Input Clock Frequency in Bypass mode	—	—	50	MHz
Input Clock Rise/Fall Time in Bypass mode	—	—	1	ns
Input Clock Duty Cycle in Bypass mode	47.50	50	52.50	%

Table 25 shows core output clock specification.

Table 25. Core output clock specification

Parameter	Min	Typ	Max	Unit
Output Clock Frequency in OSC mode	20	—	40	MHz
Output Clock Duty Cycle in OSC mode	45	50	55	%
Output Clock Frequency in Bypass mode	—	—	50	MHz
Capacitive Loading on Outputs Clock	—	150	500	fF
Output Clock Rise/Fall Time in Bypass mode	—	0.1	0.5	ns
Output Clock Duty Cycle in Bypass mode	40	50	60	%

Table 26 shows VIL/VIH specification at EXTAL.

Table 26. Transconductance specification of oscillator

Parameter	Condition	Min	Max	Unit
V _I EXTAL	V _{REF} = 0.5 x avdd (xosc HV supply)	0	V _{REF} - 0.5	V
V _I HEXTAL		V _{REF} + 0.5	avdd	

3.5 I/O DC parameters

This section includes the DC parameters of the following I/O types:

- General Purpose I/O (GPIO)
- Double Data Rate I/O (DDR) for LPDDR4, DDR4, and DDR3L modes
- Differential I/O (CLKx)

3.5.1 General purpose I/O (GPIO) DC parameters

Table 27 shows DC parameters for GPIO pads. The parameters in Table 27 are guaranteed per the operating ranges in Table 8, unless otherwise noted.

Table 27. GPIO DC parameters

Parameter	Symbol	Test Conditions	Min	Typ	Max	Unit
High-level output voltage	$V_{OH(1.8V)}$	Min V_{DD} , $I_{OH} = -100 \mu A$, $I_{OH} = -2 mA$	$V_{DD} - 0.2$, $V_{DD} - 0.45$	—	—	V
	$V_{OH(3.3V)}$		$V_{DD} - 0.2$ 2.4	—	—	V
Low-level output voltage	$V_{OL(1.8V)}$	Min V_{DD} , $I_{OH} = 100 \mu A$, $I_{OH} = 3 mA$	—	—	0.2 $0.2 \times V_{DD}$	V
	$V_{OL(3.3V)}$		—	—	0.2 0.4	V
High-level input voltage	$V_{IH(1.8V)}$	$ipp_lvttl_en = 0$	$0.7 \times V_{DD}$	—	V_{DD}	V
	$V_{IH(3.3V)}$	$ipp_lvttl_en = 1$	2	—	V_{DD}	V
	V_{IH_1VCOMS} (3.3 V)	$ipp_lvttl_en = 0$	$0.7 \times V_{DD}$	—	V_{DD}	V
Low-level input voltage	$V_{IL(1.8V)}$	$ipp_lvttl_en = 0$	0	—	$0.2 \times V_{DD}$	V
	V_{IL_emmc} (1.8 V)	$ipp_lvttl_en = 0$	0	—	$0.35 \times V_{DD}$	V
	$V_{IL(3.3V)}$	$ipp_lvttl_en = 1$	0	—	0.8	V
	V_{IL_emmc} (3.3 V)	$ipp_lvttl_en = 0$	0	—	$0.25 \times V_{DD}$	V
	V_{IL_1vcmos} (3.3 V)	$ipp_lvttl_en = 0$	0	—	$0.2 \times V_{DD}$	V
Input hysteresis	$V_{HYS(1.8V)}$	$ipp_hys = 1$	—	0.15	—	V
	$V_{HYS(3.3V)}$	$ipp_hys = 1$	—	0.2	—	V
Pull-up resistor	—	—	30×0.75	30	30×1.25	$K\Omega$
Pull-down resistor	—	—	95×0.75	95	95×1.25	$K\Omega$
High level input current ¹	I_{IH}	—	-50	—	50	μA
Low level input current ¹	I_{IL}	—	-50	—	50	μA

¹ The leakage limit for the following pins: HDMI_TX (several) is $\pm 200 \mu\text{A}$; HDMI_AUX_N/P is $\pm 65 \mu\text{A}$; PMIC_ON_REQ is $\pm 60 \mu\text{A}$; PMIC_STBY_REQ is $\pm 80 \mu\text{A}$; RTC_RESET_B is $\pm 60 \mu\text{A}$; ONOFF is $\pm 60 \mu\text{A}$; POR_B is $\pm 60 \mu\text{A}$; and SD2_CD_B is $\pm 60 \mu\text{A}$.

3.5.2 DDR I/O DC electrical characteristics

The DDR I/O pads support LPDDR 4, DDR4, and DDR3L operational modes. The DDR Memory Controller (DDRMC) is designed to be compatible with JEDEC-compliant SDRAMs.

DDRMC operation is contingent upon the board's DDR design adherence to the DDR design and layout requirements stated in the hardware development guide for the i.MX 8M Dual / 8M QuadLite / 8M Quad application processor.

Table 28. DC input logic level

Characteristics	Symbol	Min	Max	Unit
DC input logic high ¹	$V_{IH(DC)}$	$V_{REF} + 100$	—	mV
DC input logic low	$V_{IL(DC)}$	—	$V_{REF} - 100$	

¹ It is the relationship of the V_{DDQ} of the driving device and the V_{REF} of the receiving device that determines noise margins. However, in the case of $V_{IH(DC)}$ max (that is, input overdrive), it is the V_{DDQ} of the receiving device that is referenced.

Table 29. Output DC current drive

Characteristics	Symbol	Min	Max	Unit
Output minimum source DC current ¹	$I_{OH(DC)}$	-4	—	mA
Output minimum sink DC current	$I_{OL(DC)}$	4	—	mA
DC output high voltage($I_{OH} = -0.1\text{mA}$) ²	V_{OH}	$0.9 \times V_{DDQ}$	—	V
DC output low voltage($I_{OL} = 0.1\text{mA}$) ²	V_{OL}	—	$0.1 \times V_{DDQ}$	V

¹ When DDS = [111] and without ZQ calibration.

² The values of V_{OH} and V_{OL} are valid only for 1.2 V range.

Table 30. Input DC current¹

Characteristics	Symbol	Min	Max	Unit
High level input current ^{2,3}	I_{IH}	-40	40	μA
Low level input current ³	I_{IL}	-40	40	μA

¹ The leakage limit for the following pins: DRAM_AC00, DRAM_AC01, DRAM_AC20, and DRAM_AC21 are $\pm 300 \mu\text{A}$; DRAM_RESET_N is $\pm 200 \mu\text{A}$.

² The values of V_{OH} and V_{OL} are valid only for 1.2 V range.

³ Driver Hi-Z and input power-down (PD = High)

3.5.2.1 LPDDR4 mode I/O DC parameters

Table 31. LPDDR4 I/O DC electrical parameters

Parameters	Symbol	Test Conditions	Min	Max	Unit
High-level output voltage	VOH	Ioh= -0.1 mA	0.9 x OVDD	—	V
Low-level output voltage	VOL	Iol= 0.1 mA	—	0.1 x OVDD	V
Input Reference Voltage	Vref	—	0.49 x OVDD	0.51 x OVDD	V
DC High-Level input voltage	Vih_DC	—	VRef + 0.100	OVDD	V
DC Low-Level input voltage	Vil_DC	—	OVSS	VRef – 0.100	V
Differential Input Logic High	Vih_diff	—	0.26	See note ¹	—
Differential Input Logic Low	Vil_diff	—	See note	-0.26	—
Pull-up/Pull-down Impedance Mismatch	Mmpupd	—	-15	15	%
240 Ω unit calibration resolution	Rres	—	—	10	Ω
Keeper Circuit Resistance	Rkeep	—	110	175	KΩ
Input current (no pull-up/down)	Iin	VI = 0, VI = OVDD	-2.5	2.5	μA

¹ The single-ended signals need to be within the respective limits (Vih(dc) max, Vil(dc) min) for single-ended signals as well as the limitations for overshoot and undershoot.

3.5.3 Differential I/O port (CLKx_P/N)

The clock I/O interface is designed to be compatible with TIA/EIA 644-A standard. See TIA/EIA STANDARD 644-A, *Electrical Characteristics of Low Voltage Differential Signaling (LVDS) Interface Circuits* (2001), for details.

The CLK1_P/CLK1_N is input only, while CLK2_P/CLK2_N is output only.

3.6 I/O AC parameters

This section includes the AC parameters of the following I/O types:

- General Purpose I/O (GPIO)
- Double Data Rate I/O (DDR) for DDR3L/DDR4/LPDDR4 modes
- Differential I/O (CLKx)

The GPIO and DDR I/O load circuit and output transition time waveforms are shown in [Figure 4](#) and [Figure 5](#).

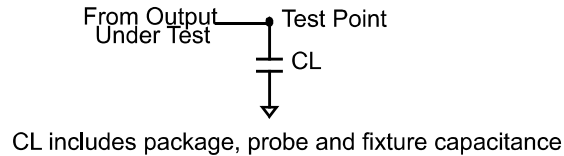

Figure 4. Load circuit for output

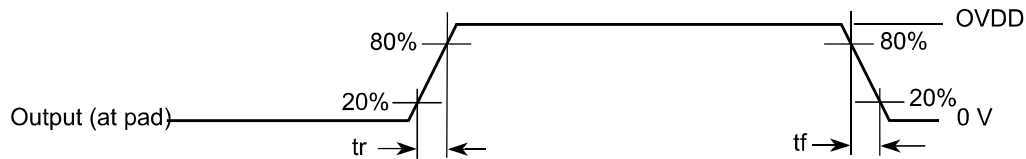

Figure 5. Output transition time waveform

3.6.1 General purpose I/O AC parameters

This section presents the I/O AC parameters for GPIO in different modes. Note that the fast or slow I/O behavior is determined by the appropriate control bits in the IOMUXC control registers.

Table 32. Maximum input cell delay time

Cell name	Max Delay PAD → Y (ns)		
	V _{DD} = 1.62 V T = 125°C WCS model	—	V _{DD} = 3.0V T = 125°C WCS model
PBIJGTOV36PUD_MCLAMP_LVGPIO_EW	1.54	—	1.3

Table 33. Output cell delay time for fixed load

Parameter			Simulated Cell Delay A → PAD (ns)	
			V _{DD} = 1.62 V, T = 125°C	V _{DD} = 2.97 V, T = 125°C
dse[2:0]	fsel[1:0]	Driver Type	CL = 15 pF	CL = 15 pF
011	00	3 x Slow Slew	3.1	3.3
011	11	3 x Fast Slew	2.1	2.6
100	00	4 x Slow Slew	3.7	3.9
100	11	4 x Fast Slew	2.3	2.8
101	00	5 x Slow Slew	3.1	3.5
101	11	5 x Fast Slew	2.1	2.5

Table 33. Output cell delay time for fixed load (continued)

Parameter			Simulated Cell Delay A → PAD (ns)	
			VDD = 1.62 V, T = 125°C	VDD = 2.97 V, T = 125°C
dse[2:0]	fsel[1:0]	Driver Type	CL = 15 pF	CL = 15 pF
111	00	7 x Slow Slew	2.9	3.1
111	11	7 x Fast Slew	1.8	2.3

Table 34. Maximum frequency of operation for input

Maximum frequency (MHz)		
VDD = 1.8 V, CL = 15 pF, fast	—	VDD = 3.3 V, CL = 20 pF, fast
200	—	160

3.6.2 Clock I/O AC parameters—CLKx_N/CLKx_P

The differential output transition time waveform is shown in Figure 6.

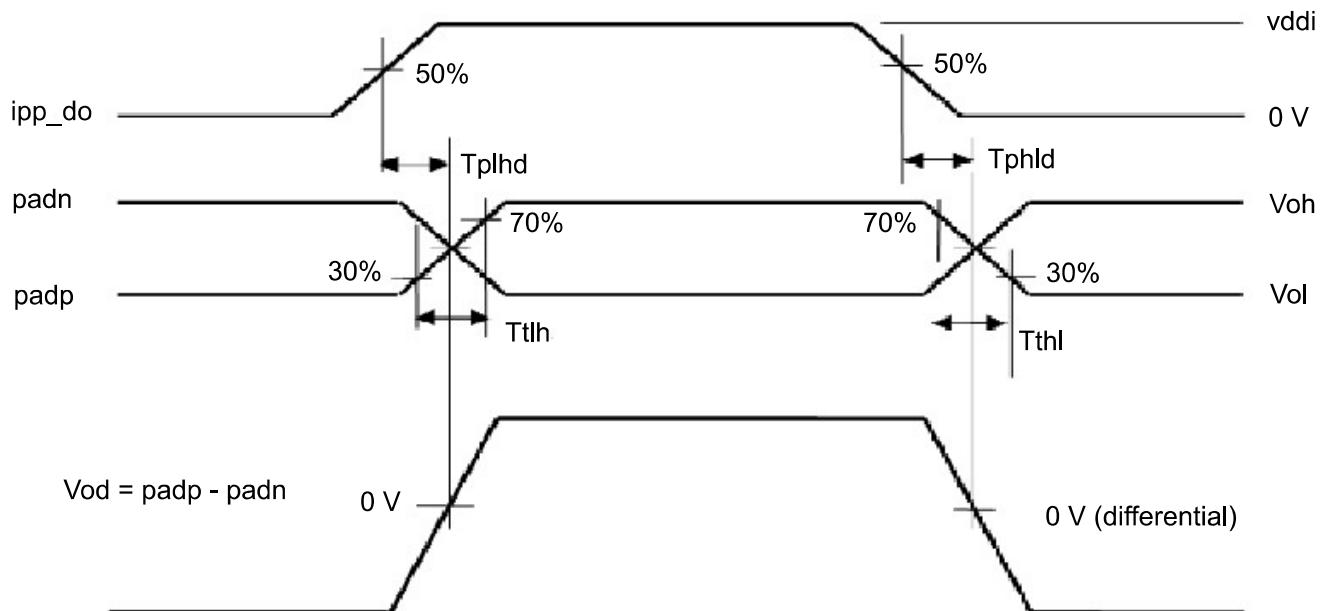

Figure 6. Differential LVDS driver transition time waveform

Table 35 shows the AC parameters for clock I/O.

Table 35. I/O AC parameters of LVDS pad

Symbol	Parameter	Test conditions	Min	Typ	Max	Unit	Notes
Tphld	Output Differential propagation delay high to low	Rload = 100 Ω between padp and padn, Cload = 2pF, at 125 °C, TYP, 1.62 V OVDD, and 0.9 V VDDI	—	—	0.92	ns	1
Tplhd	Output Differential propagation delay low to high		—	—	0.92		
Ttlh	Output Transition time low to high		—	—	0.58	2	
Tthl	Output Transition time high to low		—	—	0.73		
Tphlr	Input Differential propagation delay high to low	Rload = 100 Ω between padp and padn, at 125 °C, TYP, 1.62 V OVDD, and 0.9 V VDDI	—	—	0.83	ns	3
Tplhr	Input Differential propagation delay low to high		—	—	0.83		
Ttx	Transmitter startup time (ipp-obc low to high)	—	—	40	ns	4	
F	Operating frequency	—	—	600	1000	MHz	—

¹ At TYP, 125 °C, 1.62 V OVDD, and 0.9 V VDDI. Measurement levels are 50 - 50%. Output differential signal measured.

² At TYP, 125 °C, 1.62 V OVDD, and 0.9 V VDDI. Measurement levels are 20 - 80%. Output differential signal measured.

³ At TYP, 125 °C, 1.62 V OVDD, and 0.9 V VDDI. Measurement levels are 50 - 50%.

⁴ TX startup time is defined as the time taken by transmitter for settling after its ipp_obc has been asserted. It is to stabilize the current reference. Functionality is guaranteed only after the startup time.

3.7 Output buffer impedance parameters

This section defines the I/O impedance parameters of the i.MX 8M Dual / 8M QuadLite / 8M Quad processors for the following I/O types:

- Double Data Rate I/O (DDR) for LPDDR4, DDR4, and DDR3L modes
- Differential I/O (CLKx)

NOTE

DDR I/O output driver impedance is measured with “long” transmission line of impedance Ztl attached to I/O pad and incident wave launched into transmission line. Rpu/Rpd and Ztl form a voltage divider that defines specific voltage of incident wave relative to OVDD. Output driver impedance is calculated from this voltage divider (see [Figure 7](#)).

Electrical characteristics

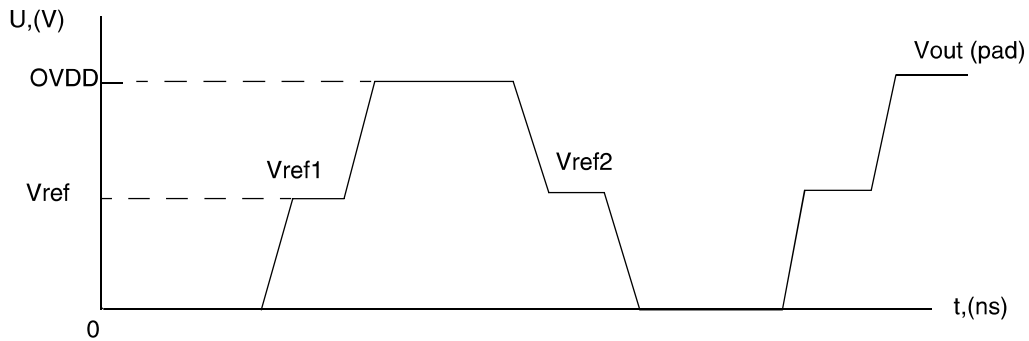
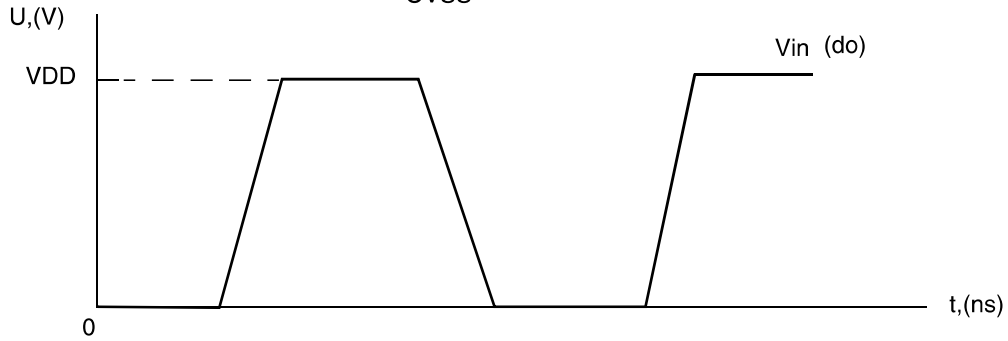
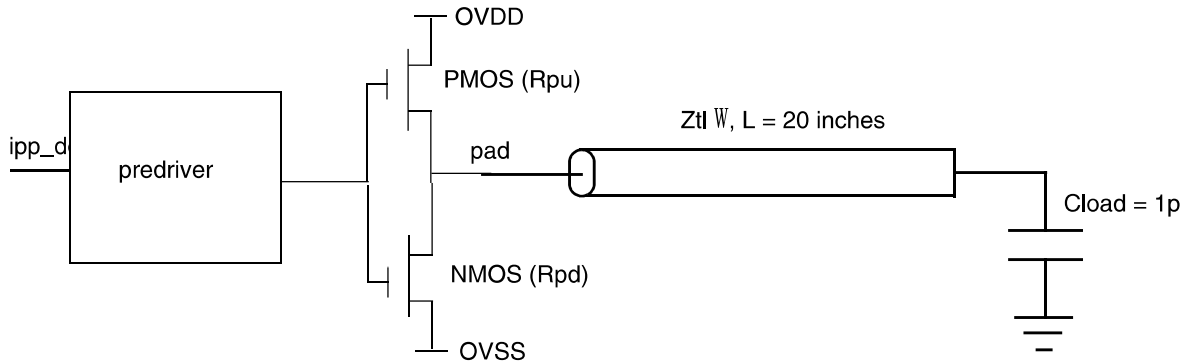

$$R_{pu} = \frac{V_{ovdd} - V_{ref1}}{V_{ref1}} \times Z_{tl}$$

$$R_{pd} = \frac{V_{ref2}}{V_{ovdd} - V_{ref2}} \times Z_{tl}$$

Figure 7. Impedance matching load for measurement

3.7.1 DDR I/O output buffer impedance

Table 36 shows DDR I/O output buffer impedance of i.MX 8M Dual / 8M QuadLite / 8M Quad processors.

Table 36. DDR I/O output buffer impedance

Parameter	Symbol	Test Conditions DSE (Drive Strength)	Typical			Unit
			NVCC_DRAM = 1.35 V (DDR3L) DDR_SEL = 11	NVCC_DRAM = 1.2 V (DDR4)	NVCC_DRAM = 1.1 V (LPDDR4) DDR_SEL = 10	
Output Driver Impedance	Rdrv	000000	Hi-Z	Hi-Z	Hi-Z	Ω
		000010	240	240	240	
		000110	120	120	120	
		001010	80	80	80	
		001110	60	60	60	
		011010	48	48	48	
		011110	40	40	40	
		111010	34	34	34	

Note:

1. Output driver impedance is controlled across PVTs using ZQ calibration procedure.
2. Calibration is done against 240 Ω external reference resistor.
3. Output driver impedance deviation (calibration accuracy) is $\pm 5\%$ (max/min impedance) across PVTs.

3.7.2 Differential I/O output buffer impedance

The Differential CCM interface is designed to be compatible with TIA/EIA 644-A standard. See, TIA/EIA STANDARD 644-A, *Electrical Characteristics of Low Voltage Differential Signaling (LVDS) Interface Circuits* (2001) for details.

3.8 System modules timing

This section contains the timing and electrical parameters for the modules in each i.MX 8M Dual / 8M QuadLite / 8M Quad processor.

3.8.1 Reset timings parameters

Figure 8 shows the reset timing and Table 37 lists the timing parameters.

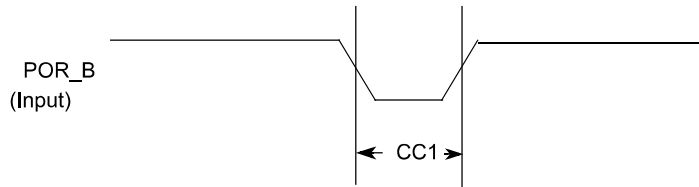

Figure 8. Reset timing diagram

Table 37. Reset timing parameters

ID	Parameter	Min	Max	Unit
CC1	Duration of POR_B to be qualified as valid.	1	—	RTC_XTALI cycle

3.8.2 WDOG Reset timing parameters

Figure 9 shows the WDOG reset timing and Table 38 lists the timing parameters.

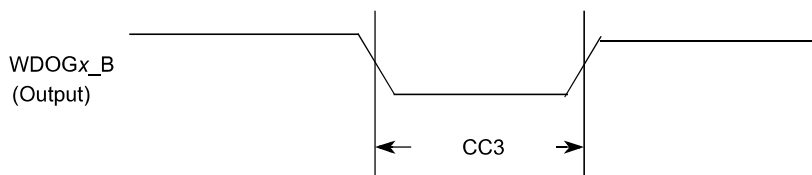

Figure 9. WDOGx_B timing diagram

Table 38. WDOGx_B timing parameters

ID	Parameter	Min	Max	Unit
CC3	Duration of WDOG1_B Assertion	1	—	RTC_XTALI cycle

NOTE

RTC_XTALI is approximately 32 kHz. RTC_XTALI cycle is one period or approximately 30 ms.

NOTE

WDOGx_B output signals (for each one of the Watchdog modules) do not have dedicated pins, but are muxed out through the IOMUX. See the IOMUXC chapter of the *i.MX 8M Dual / 8M QuadLite / 8M Quad Applications Processor Reference Manual (IMX8MDQLQRM)* for detailed information.

3.9 External peripheral interface parameters

The following subsections provide information on external peripheral interfaces.

3.9.1 ECSPI timing parameters

This section describes the timing parameters of the ECSPI blocks. The ECSPI have separate timing parameters for master and slave modes.

3.9.1.1 ECSPI Master mode timing

Figure 10 depicts the timing of ECSPI in master mode. Table 39 lists the ECSPI master mode timing characteristics.

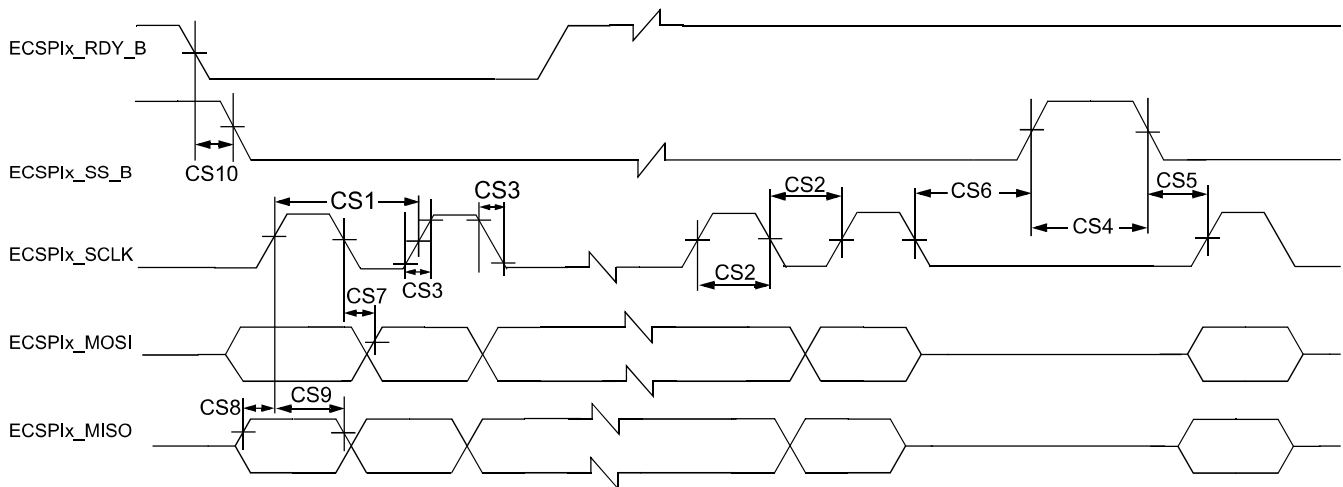

Figure 10. ECSPI Master mode timing diagram

Table 39. ECSPI Master mode timing parameters

ID	Parameter	Symbol	Min	Max	Unit
CS1	ECSPi_x_SCLK Cycle Time—Read ECSPi_x_SCLK Cycle Time—Write	t_{clk}	43 15	—	ns
CS2	ECSPi_x_SCLK High or Low Time—Read ECSPi_x_SCLK High or Low Time—Write	t_{sw}	21.5 7	—	ns
CS3	ECSPi_x_SCLK Rise or Fall ¹	$t_{RISE/FALL}$	—	—	ns
CS4	ECSPi_x_SS_B pulse width	t_{CSLH}	Half ECSPi_x_SCLK period	—	ns
CS5	ECSPi_x_SS_B Lead Time (CS setup time)	t_{SCS}	Half ECSPi_x_SCLK period - 4	—	ns
CS6	ECSPi_x_SS_B Lag Time (CS hold time)	t_{HCS}	Half ECSPi_x_SCLK period - 2	—	ns
CS7	ECSPi_x_MOSI Propagation Delay ($C_{LOAD} = 20$ pF)	t_{PDmosi}	-1	1	ns
CS8	ECSPi_x_MISO Setup Time	t_{Smiso}	18	—	ns
CS9	ECSPi_x_MISO Hold Time	t_{Hmiso}	0	—	ns
CS10	RDY to ECSPi_x_SS_B Time ²	t_{SDRY}	5	—	ns

¹ See specific I/O AC parameters [Section 3.6, I/O AC parameters.](#)

² SPI_RDY is sampled internally by ipg_clk and is asynchronous to all other CSPI signals.

3.9.1.2 ECSPi Slave mode timing

Figure 11 depicts the timing of ECSPi in Slave mode. Table 40 lists the ECSPi Slave mode timing characteristics.

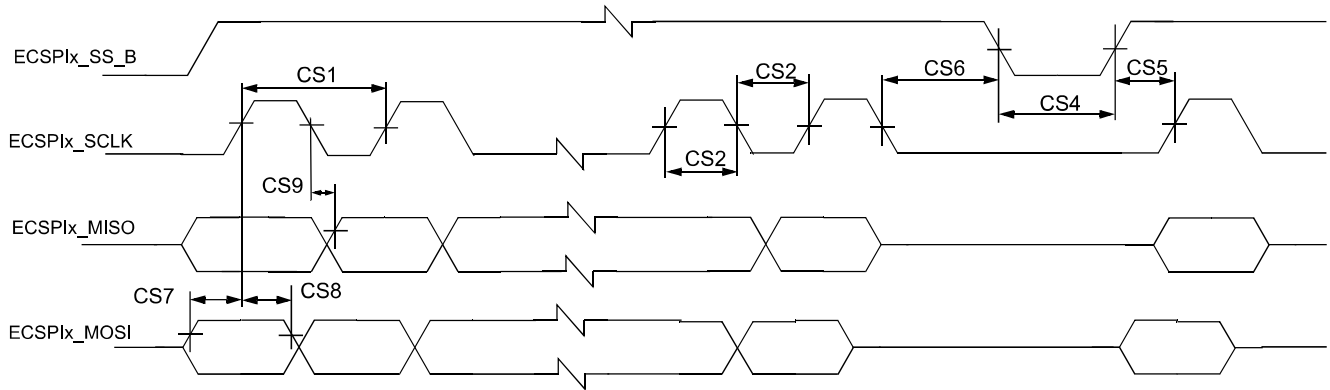

Figure 11. ECSPi Slave mode timing diagram

Table 40. ECSPi Slave mode timing parameters

ID	Parameter	Symbol	Min	Max	Unit
CS1	ECSPi_SCLK Cycle Time–Read ECSPi_SCLK Cycle Time–Write	t_{clk}	15 43	—	ns
CS2	ECSPi_SCLK High or Low Time–Read ECSPi_SCLK High or Low Time–Write	t_{sw}	7 21.5	—	ns
CS4	ECSPi_SS_B pulse width	t_{CSLH}	Half ECSPi_SCLK period	—	ns
CS5	ECSPi_SS_B Lead Time (CS setup time)	t_{SCS}	5	—	ns
CS6	ECSPi_SS_B Lag Time (CS hold time)	t_{HCS}	5	—	ns
CS7	ECSPi_MOSI Setup Time	t_{Smosi}	4	—	ns
CS8	ECSPi_MOSI Hold Time	t_{Hmosi}	4	—	ns
CS9	ECSPi_MISO Propagation Delay ($C_{LOAD} = 20\text{ pF}$)	t_{PDmiso}	4	19	ns

3.9.2 Ultra-high-speed SD/SDIO/MMC host interface (uSDHC) AC timing

This section describes the electrical information of the uSDHC, which includes SD/eMMC4.3 (single data rate) timing, eMMC4.4/4.41 (dual data rate) timing and SDR104/50 (SD3.0) timing.

3.9.2.1 SD/eMMC4.3 (single data rate) AC timing

Figure 12 depicts the timing of SD/eMMC4.3, and Table 41 lists the SD/eMMC4.3 timing characteristics.

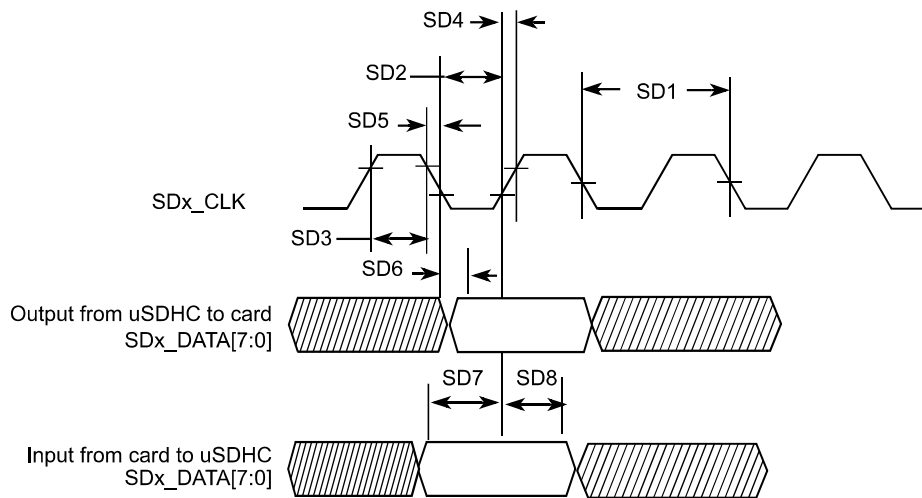

Figure 12. SD/eMMC4.3 timing

Table 41. SD/eMMC4.3 interface timing specification

ID	Parameter	Symbols	Min	Max	Unit
Card Input Clock					
SD1	Clock Frequency (Low Speed)	f_{PP}^1	0	400	kHz
	Clock Frequency (SD/SDIO Full Speed/High Speed)	f_{PP}^2	0	25/50	MHz
	Clock Frequency (MMC Full Speed/High Speed)	f_{PP}^3	0	20/52	MHz
	Clock Frequency (Identification Mode)	f_{OD}	100	400	kHz
SD2	Clock Low Time	t_{WL}	7	—	ns
SD3	Clock High Time	t_{WH}	7	—	ns
SD4	Clock Rise Time	t_{TLH}	—	3	ns
SD5	Clock Fall Time	t_{THL}	—	3	ns
uSDHC Output/Card Inputs SD_CMD, SDx_DATAx (Reference to CLK)					
SD6	uSDHC Output Delay	t_{OD}	6.6	3.6	ns

Electrical characteristics

Table 41. SD/eMMC4.3 interface timing specification (continued)

ID	Parameter	Symbols	Min	Max	Unit
uSDHC Input/Card Outputs SD_CMD, SDx_DATAx (Reference to CLK)					
SD7	uSDHC Input Setup Time	t_{ISU}	2.5	—	ns
SD8	uSDHC Input Hold Time ⁴	t_{IH}	1.5	—	ns

¹ In Low-Speed mode, card clock must be lower than 400 kHz, voltage ranges from 2.7 to 3.6 V.

² In Normal (Full) -Speed mode for SD/SDIO card, clock frequency can be any value between 0 – 25 MHz. In High-speed mode, clock frequency can be any value between 0 – 50 MHz.

³ In Normal (Full) -Speed mode for MMC card, clock frequency can be any value between 0 – 20 MHz. In High-speed mode, clock frequency can be any value between 0 – 52 MHz.

⁴ To satisfy hold timing, the delay difference between clock input and cmd/data input must not exceed 2 ns.

3.9.2.2 eMMC4.4/4.41 (dual data rate) AC timing

Figure 13 depicts the timing of eMMC4.4/4.41. Table 42 lists the eMMC4.4/4.41 timing characteristics. Be aware that only DATA is sampled on both edges of the clock (not applicable to CMD).

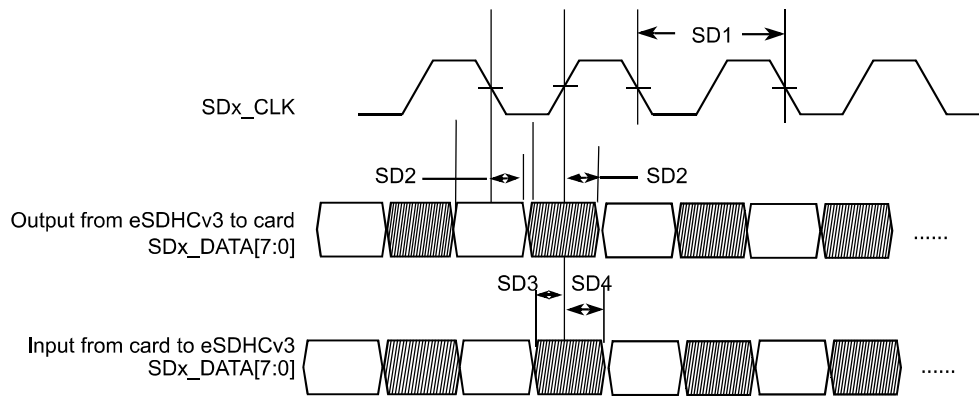

Figure 13. eMMC4.4/4.41 timing

Table 42. eMMC4.4/4.41 interface timing specification

ID	Parameter	Symbols	Min	Max	Unit
Card Input Clock					
SD1	Clock Frequency (eMMC4.4/4.41 DDR)	f_{PP}	0	52	MHz
SD1	Clock Frequency (SD3.0 DDR)	f_{PP}	0	50	MHz
uSDHC Output / Card Inputs SD_CMD, SDx_DATAx (Reference to CLK)					
SD2	uSDHC Output Delay	t_{OD}	2.7	6.9	ns
uSDHC Input / Card Outputs SD_CMD, SDx_DATAx (Reference to CLK)					

Table 42. eMMC4.4/4.41 interface timing specification (continued)

ID	Parameter	Symbols	Min	Max	Unit
SD3	uSDHC Input Setup Time	t_{ISU}	2.4	—	ns
SD4	uSDHC Input Hold Time	t_{IH}	1.3	—	ns

3.9.2.3 HS400 DDR AC timing—eMMC5.0 only

Figure 14 depicts the timing of HS400 mode, and Table 43 lists the HS400 timing characteristics. Be aware that only data is sampled on both edges of the clock (not applicable to CMD). The CMD input/output timing for HS400 mode is the same as CMD input/output timing for SDR104 mode. Check SD5, SD6, and SD7 parameters in Table 45 SDR50/SDR104 Interface Timing Specification for CMD input/output timing for HS400 mode.

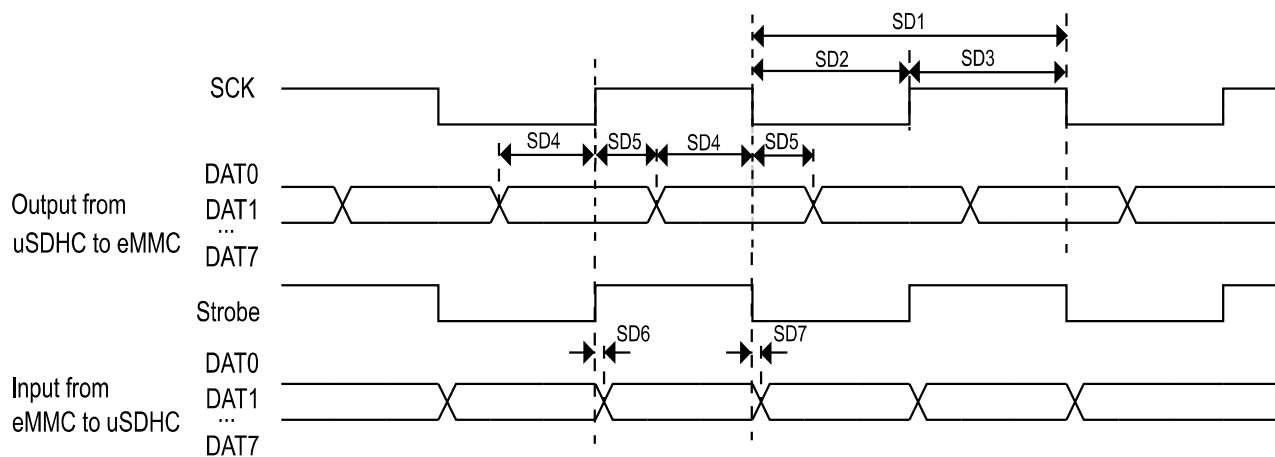

Figure 14. HS400 Mode timing

Table 43. HS400 interface timing specification

ID	Parameter	Symbols	Min	Max	Unit
Card Input Clock					
SD1	Clock frequency	f_{PP}	0	200	MHz
SD2	Clock low time	t_{CL}	$0.46 \times t_{CLK}$	$0.54 \times t_{CLK}$	ns
SD3	Clock high time	t_{CH}	$0.46 \times t_{CLK}$	$0.54 \times t_{CLK}$	ns
uSDHC Output/Card Inputs DAT (Reference to SCK)					
SD4	Output skew from data of edge of SCK	t_{OSkew1}	0.45	—	ns
SD5	Output skew from edge of SCK to data	t_{OSkew2}	0.45	—	ns
uSDHC Input/Card Outputs DAT (Reference to Strobe)					

Electrical characteristics

Table 43. HS400 interface timing specification (continued)

ID	Parameter	Symbols	Min	Max	Unit
SD6	uSDHC input skew	t_{RQ}	—	0.45	ns
SD7	uSDHC hold skew	t_{RQH}	—	0.45	ns

3.9.2.4 HS200 Mode timing

Figure 15 depicts the timing of HS200 mode, and Table 44 lists the HS200 timing characteristics.

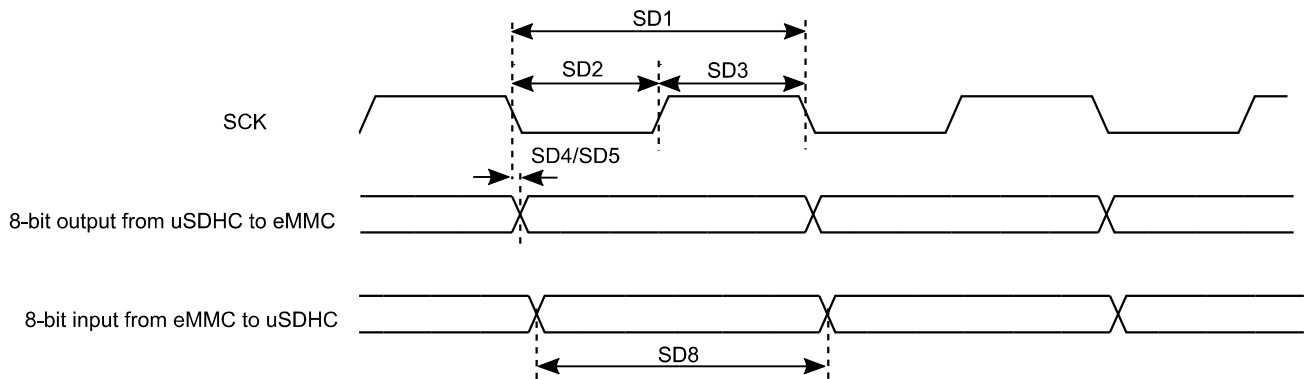

Figure 15. HS200 mode timing

Table 44. HS200 interface timing specification

ID	Parameter	Symbols	Min	Max	Unit
Card Input Clock					
SD1	Clock Frequency Period	t_{CLK}	5	—	ns
SD2	Clock Low Time	t_{CL}	$0.3 \times t_{CLK}$	$0.7 \times t_{CLK}$	ns
SD3	Clock High Time	t_{CH}	$0.3 \times t_{CLK}$	$0.7 \times t_{CLK}$	ns
uSDHC Output/Card Inputs SD_CMD, SDx_DATAx in HS200 (Reference to CLK)					
SD5	uSDHC Output Delay	t_{OD}	-1.6	1	ns
uSDHC Input/Card Outputs SD_CMD, SDx_DATAx in HS200 (Reference to CLK)¹					
SD8	uSDHC Output Data Window	t_{ODW}	$0.5 \times t_{CLK}$	—	ns

¹ HS200 is for 8 bits while SDR104 is for 4 bits.

3.9.2.5 SDR50/SDR104 AC timing

Figure 16 depicts the timing of SDR50/SDR104, and Table 45 lists the SDR50/SDR104 timing characteristics.

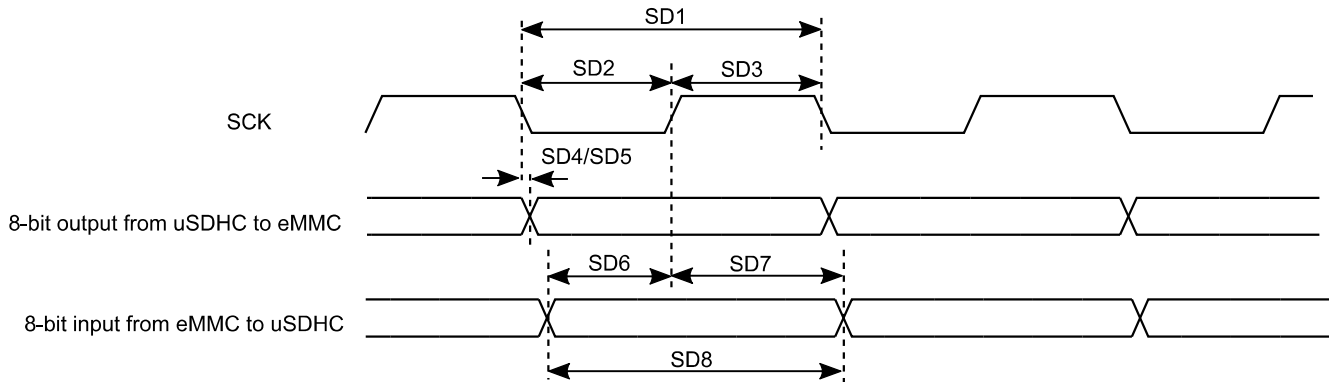

Figure 16. SDR50/SDR104 timing

Table 45. SDR50/SDR104 interface timing specification

ID	Parameter	Symbols	Min	Max	Unit
Card Input Clock					
SD1	Clock Frequency Period	t_{CLK}	5	—	ns
SD2	Clock Low Time	t_{CL}	$0.46 \times t_{CLK}$	$0.54 \times t_{CLK}$	ns
SD3	Clock High Time	t_{CH}	$0.46 \times t_{CLK}$	$0.54 \times t_{CLK}$	ns
uSDHC Output/Card Inputs SD_CMD, SDx_DATAx in SDR50 (Reference to CLK)					
SD4	uSDHC Output Delay	t_{OD}	-3	1	ns
uSDHC Output/Card Inputs SD_CMD, SDx_DATAx in SDR104 (Reference to CLK)					
SD5	uSDHC Output Delay	t_{OD}	-1.6	1	ns
uSDHC Input/Card Outputs SD_CMD, SDx_DATAx in SDR50 (Reference to CLK)					
SD6	uSDHC Input Setup Time	t_{ISU}	2.4	—	ns
SD7	uSDHC Input Hold Time	t_{IH}	1.4	—	ns
uSDHC Input/Card Outputs SD_CMD, SDx_DATAx in SDR104 (Reference to CLK)¹					
SD8	uSDHC Output Data Window	t_{ODW}	$0.5 \times t_{CLK}$	—	ns

¹ Data window in SDR100 mode is variable.

3.9.2.6 Bus operation condition for 3.3 V and 1.8 V signaling

Signaling level of SD/eMMC4.3 and eMMC4.4/4.41 modes is 3.3 V. Signaling level of SDR104/SDR50 mode is 1.8 V. The DC parameters for the NVCC_SD1, NVCC_SD2 and NVCC_SD3 supplies are identical to those shown in Table 27, "GPIO DC parameters," on page 32.

3.9.3 Ethernet controller (ENET) AC electrical specifications

The following timing specs are defined at the chip I/O pin and must be translated appropriately to arrive at timing specs/constraints for the physical interface.

3.9.3.1 RMI mode timing

Figure 17 shows RMI mode timings. Table 46 describes the timing parameters (M16–M21) shown in the figure.

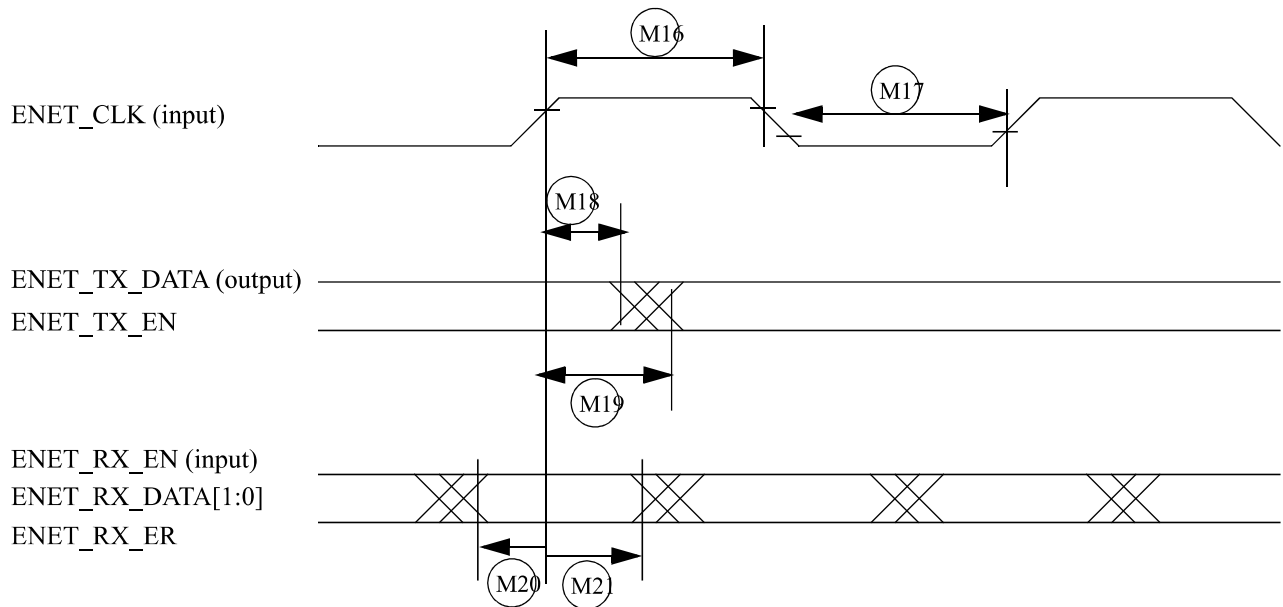

Figure 17. RMI mode signal timing diagram

Table 46. RMI signal timing

ID	Characteristic	Min.	Max.	Unit
M16	ENET_CLK pulse width high	35%	65%	ENET_CLK period
M17	ENET_CLK pulse width low	35%	65%	ENET_CLK period
M18	ENET_CLK to ENET0_TXD[1:0], ENET_TX_DATA invalid	4	—	ns
M19	ENET_CLK to ENET0_TXD[1:0], ENET_TX_DATA valid	—	15	ns
M20	ENET_RX_DATAD[1:0], ENET_RX_EN(ENET_RX_EN), ENET_RX_ER to ENET_CLK setup	4	—	ns
M21	ENET_CLK to ENET_RX_DATAD[1:0], ENET_RX_EN, ENET_RX_ER hold	2	—	ns

Table 47. RMII signal mapping

Pad name	Description	Mode	Alt Mode	Direction	Comment
ENET_MDC	enet1.MDC	RMII/RGMII	ALT0	O	—
ENET_MDIO	enet1.MDIO	RMII/RGMII	ALT0	I/O	—
ENET_TD3	RGMII.TD3	RGMII	ALT0	O	Only used for RGMII
ENET_TD2	RMII.CLK; RGMII.TD2	RMII/RGMII	ALT0	I/O	Used as RMII clock and RGMII data, there are two RGMII clock schemes. <ul style="list-style-type: none"> • MAC generate output 50M reference clock for PHY, and MAC also uses this 50M clock. • MAC uses external 50M clock.
ENET_TD1	RMII and RGMII.TD1	RMII/RGMII	ALT0	O	—
ENET_TD0	RMII and RGMII.TD0	RMII/RGMII	ALT0	O	—
ENET_TX_CTL	RMII.TX_EN; RGMII.TX_CTL	RMII/RGMII	ALT0	O	—
ENET_TXC	RMII.TX_ERR; RGMII.TX_CLK	RGMII	ALT0/ALT1	O	For RMII, ENET_TXC works as RMII.TX_ERR, need to work in the ALT1 mode. For RGMII, ENET_TXC works as RGMII_TX_CLK, need to work in the ALT0 mode.
ENET_RX_CTL	RMII.RX_EN (CRS_DV); RGMII.RX_CTL	RMII/RGMII	ALT0	I	—
ENET_RXC	RMII.RX_ERR; RGMII.RX_CLK	RGMII	ALT0/ALT1	I	For RMII, ENET_RXC works as RMII.RX_ERR, need to work in the ALT1 mode. For RGMII, ENET_RXC works as RGMII_RX_CLK, need to work in the ALT0 mode.
ENET_RD0	RMII and RGMII.RD0	RMII/RGMII	ALT0	I	—
ENET_RD1	RMII and RGMII.RD1	RMII/RGMII	ALT0	I	—
ENET_RD2	RGMII RD2	RGMII	ALT0	I	—
ENET_RD3	RGMII RD3	RGMII	ALT0	I	—
GPIO1_IO06	enet1.MDC	RMII/RGMII	ALT1	O	—
GPIO1_IO07	enet1.MDIO	RMII/RGMII	ALT1	I/O	—

Table 47. RMII signal mapping (continued)

Pad name	Description	Mode	Alt Mode	Direction	Comment
I2C1_SCL	enet1.MDC	RMII/RGMII	ALT1	O	—
I2C1_SDA	enet1.MDIO	RMII/RGMII	ALT1	I/O	—
GPIO1_IO08	enet1.1588_EVE NTO_IN	RMII/RGMII	ALT1	I	Capture/compare block input/output event bus signal. When configured for capture and a rising edge is detected, the current timer value is latched and transferred into the corresponding ENET_TCCRn register for inspection by software. When configured for comparison, the corresponding signal 1588_EVENT is asserted for one cycle when the timer reaches the comparison value programmed in the register ENET_TCCRn. An interrupt or DMA request can be triggered if the corresponding bit in the ENET_TCSRn[TIE] or ENET_TCSRn[TDRE] is set.
GPIO1_IO00	ENET_PHY_REF _CLK_ROOT	RGMII	ALT1	O	Reference clock is for PHY.

3.9.3.2 RGMII signal switching specifications

The following timing specifications meet the requirements for RGMII interfaces for a range of transceiver devices.

Table 48. RGMII signal switching specifications¹

Symbol	Description	Min.	Max.	Unit
T_{cyc}^2	Clock cycle duration	7.2	8.8	ns
T_{skewT}^3	Data to clock output skew at transmitter	-500	500	ps
T_{skewR}^3	Data to clock input skew at receiver	1	2.6	ns
Duty_G ⁴	Duty cycle for Gigabit	45	85	%
Duty_T ⁴	Duty cycle for 10/100T	40	90	%
Tr/Tf	Rise/fall time (20–80%)	—	0.98	ns

¹ The timings assume the following configuration:

DDR_SEL = (11)b

DSE (drive-strength) = (111)b

² For 10 Mbps and 100 Mbps, T_{cyc} will scale to 400 ns \pm 40 ns and 40 ns \pm 4 ns respectively.

³ For all versions of RGMII prior to 2.0; this implies that PC board design will require clocks to be routed such that an additional trace delay of greater than 1.5 ns and less than 2.0 ns will be added to the associated clock signal. For 10/100, the Max value is unspecified.

⁴ Duty cycle may be stretched/shrunk during speed changes or while transitioning to a received packet's clock domain as long as minimum duty cycle is not violated and stretching occurs for no more than three T_{cyc} of the lowest speed transitioned between.

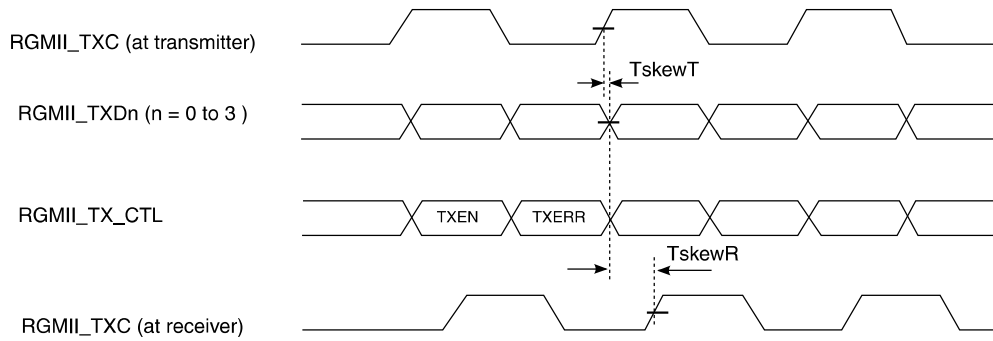

Figure 18. RGMII transmit signal timing diagram original

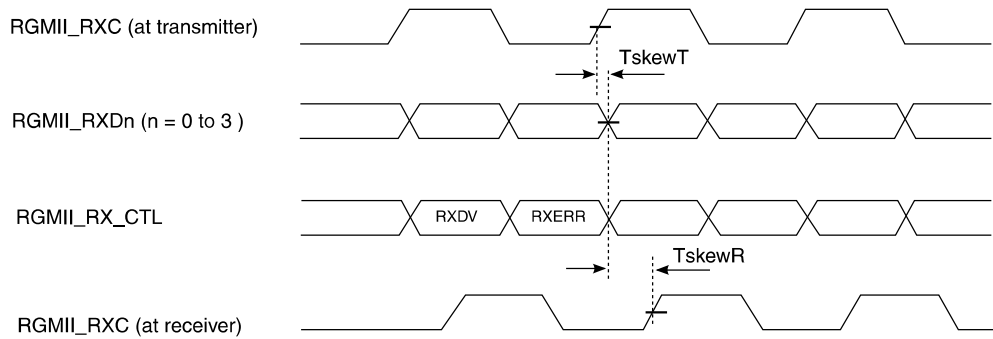

Figure 19. RGMII receive signal timing diagram original

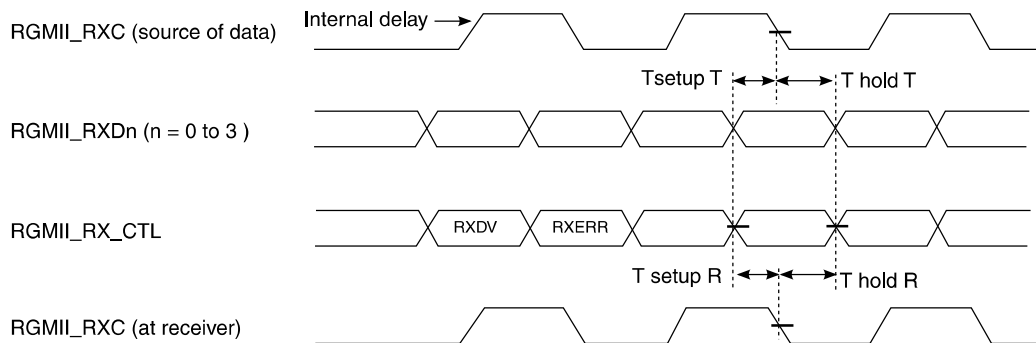

Figure 20. RGMII receive signal timing diagram with internal delay

3.9.4 General-purpose media interface (GMPI) timing

The GMPI controller of the i.MX 8M Dual / 8M QuadLite / 8M Quad processor is a flexible interface NAND Flash controller with 8-bit data width, up to 200 MB/s I/O speed and individual chip select.

It supports Asynchronous Timing mode, Source Synchronous Timing mode and Toggle Timing mode separately, as described in the following subsections.

3.9.4.1 Asynchronous mode AC timing (ONFI 1.0 compatible)

Asynchronous mode AC timings are provided as multiplications of the clock cycle and fixed delay. The maximum I/O speed of GPMI in Asynchronous mode is about 50 MB/s. Figure 21 through Figure 24 depicts the relative timing between GPMI signals at the module level for different operations under Asynchronous mode. Table 49 describes the timing parameters (NF1–NF17) that are shown in the figures.

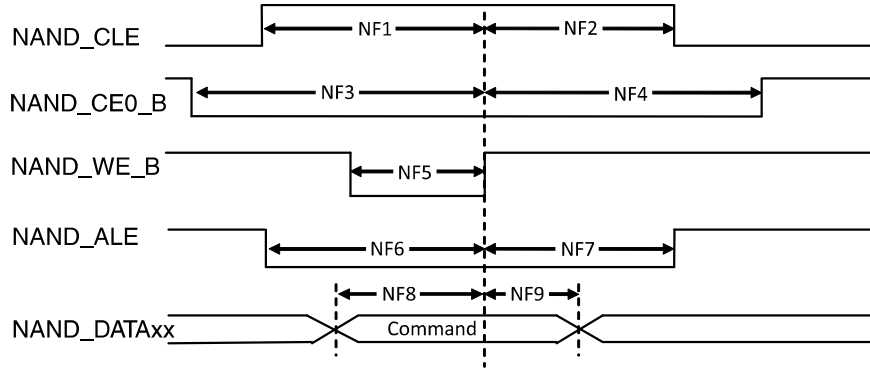

Figure 21. Command Latch cycle timing diagram

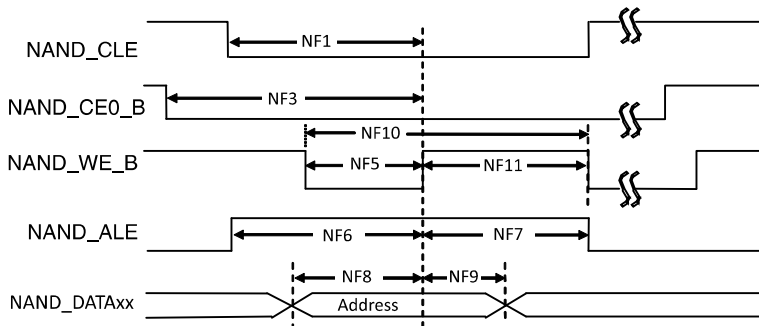

Figure 22. Address Latch cycle timing diagram

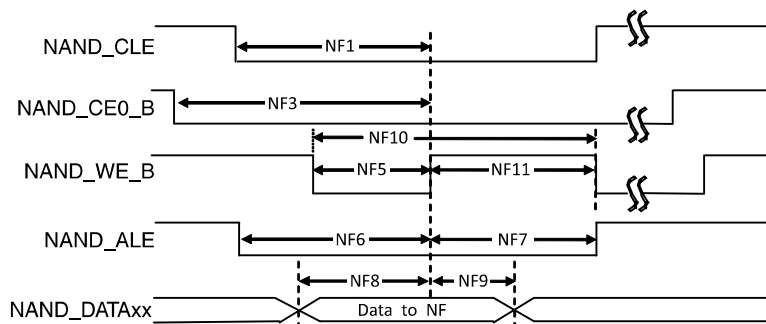

Figure 23. Write Data Latch cycle timing diagram

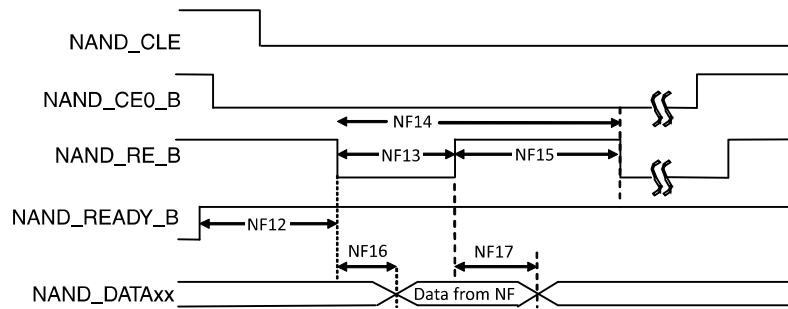

Figure 24. Read Data Latch cycle timing diagram (Non-EDO Mode)

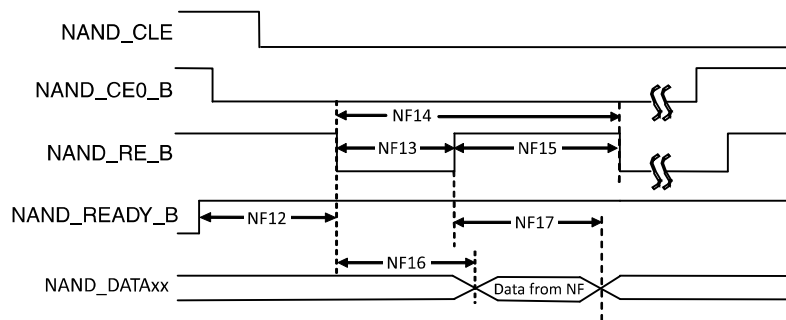

Figure 25. Read Data Latch cycle timing diagram (EDO mode)

Table 49. Asynchronous mode timing parameters¹

ID	Parameter	Symbol	Timing T = GPML Clock Cycle		Unit
			Min.	Max.	
NF1	NAND_CLE setup time	tCLS	$(AS + DS) \times T - 0.12$ [see notes ^{2,3}]		ns
NF2	NAND_CLE hold time	tCLH	$DH \times T - 0.72$ [see note ²]		ns
NF3	NAND_CE0_B setup time	tCS	$(AS + DS + 1) \times T$ [see notes ^{3,2}]		ns
NF4	NAND_CE0_B hold time	tCH	$(DH+1) \times T - 1$ [see note ²]		ns
NF5	NAND_WE_B pulse width	tWP	$DS \times T$ [see note ²]		ns
NF6	NAND_ALE setup time	tALS	$(AS + DS) \times T - 0.49$ [see notes ^{3,2}]		ns
NF7	NAND_ALE hold time	tALH	$DH \times T - 0.42$ [see note ²]		ns
NF8	Data setup time	tDS	$DS \times T - 0.26$ [see note ²]		ns
NF9	Data hold time	tDH	$DH \times T - 1.37$ [see note ²]		ns
NF10	Write cycle time	tWC	$(DS + DH) \times T$ [see note ²]		ns
NF11	NAND_WE_B hold time	tWH	$DH \times T$ [see note ²]		ns
NF12	Ready to NAND_RE_B low	tRR ⁴	$(AS + 2) \times T$ [see ^{3,2}]	—	ns
NF13	NAND_RE_B pulse width	tRP	$DS \times T$ [see note ²]		ns
NF14	READ cycle time	tRC	$(DS + DH) \times T$ [see note ²]		ns
NF15	NAND_RE_B high hold time	tREH	$DH \times T$ [see note ²]		ns

Electrical characteristics

Table 49. Asynchronous mode timing parameters¹ (continued)

ID	Parameter	Symbol	Timing T = GPMI Clock Cycle		Unit
			Min.	Max.	
NF16	Data setup on read	tDSR	—	(DS × T - 0.67)/18.38 [see notes ^{5,6}]	ns
NF17	Data hold on read	tDHR	0.82/11.83 [see notes ^{5,6}]	—	ns

¹ GPMI's Asynchronous mode output timing can be controlled by the module's internal registers HW_GPMI_TIMING0_ADDRESS_SETUP, HW_GPMI_TIMING0_DATA_SETUP, and HW_GPMI_TIMING0_DATA_HOLD. This AC timing depends on these registers settings. In the table, AS/DS/DH represents each of these settings.

² AS minimum value can be 0, while DS/DH minimum value is 1.

³ T = GPMI clock period - 0.075 ns (half of maximum p-p jitter).

⁴ NF12 is guaranteed by the design.

⁵ Non-EDO mode.

⁶ EDO mode, GPMI clock ≈ 100 MHz
(AS=DS=DH=1, GPMI_CTL1 [RDN_DELAY] = 8, GPMI_CTL1 [HALF_PERIOD] = 0).

In EDO mode (Figure 24), NF16/NF17 are different from the definition in non-EDO mode (Figure 23). They are called tREA/tRHOH (RE# access time/RE# HIGH to output hold). The typical values for them are 16 ns (max for tREA)/15 ns (min for tRHOH) at 50 MB/s EDO mode. In EDO mode, GPMI samples NAND_DATAxx at the rising edge of delayed NAND_RE_B provided by an internal DPLL. The delay value can be controlled by GPMI_CTRL1.RDN_DELAY (see the GPMI chapter of the *i.MX 8M Dual / 8M QuadLite / 8M Quad Applications Processor Reference Manual* [IMX8MDQLQRM]). The typical value of this control register is 0x8 at 50 MT/s EDO mode. But if the board delay is big enough and cannot be ignored, the delay value should be made larger to compensate the board delay.

3.9.4.2 Source synchronous mode AC timing (ONFI 2.x compatible)

Figure 26 to Figure 28 show the write and read timing of Source Synchronous mode.

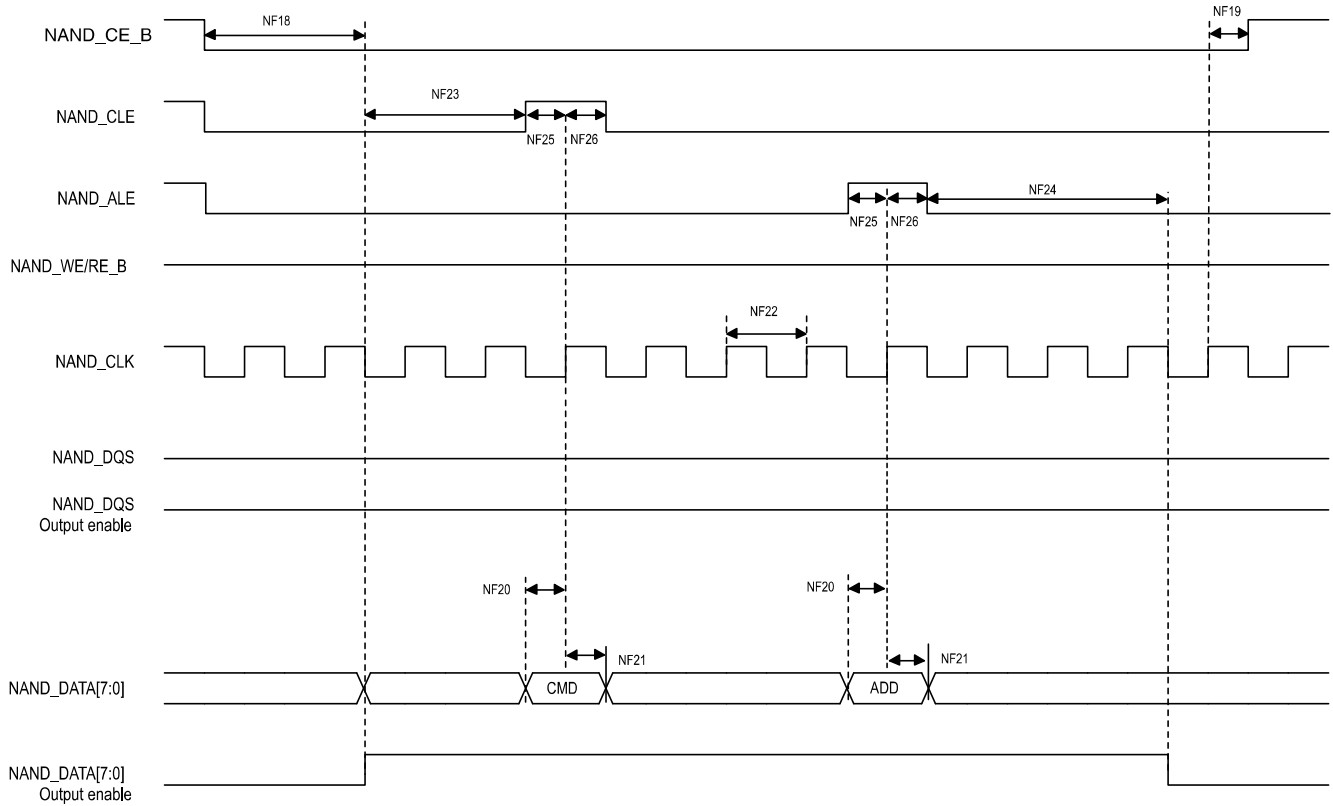

Figure 26. Source Synchronous mode command and address timing diagram

Electrical characteristics

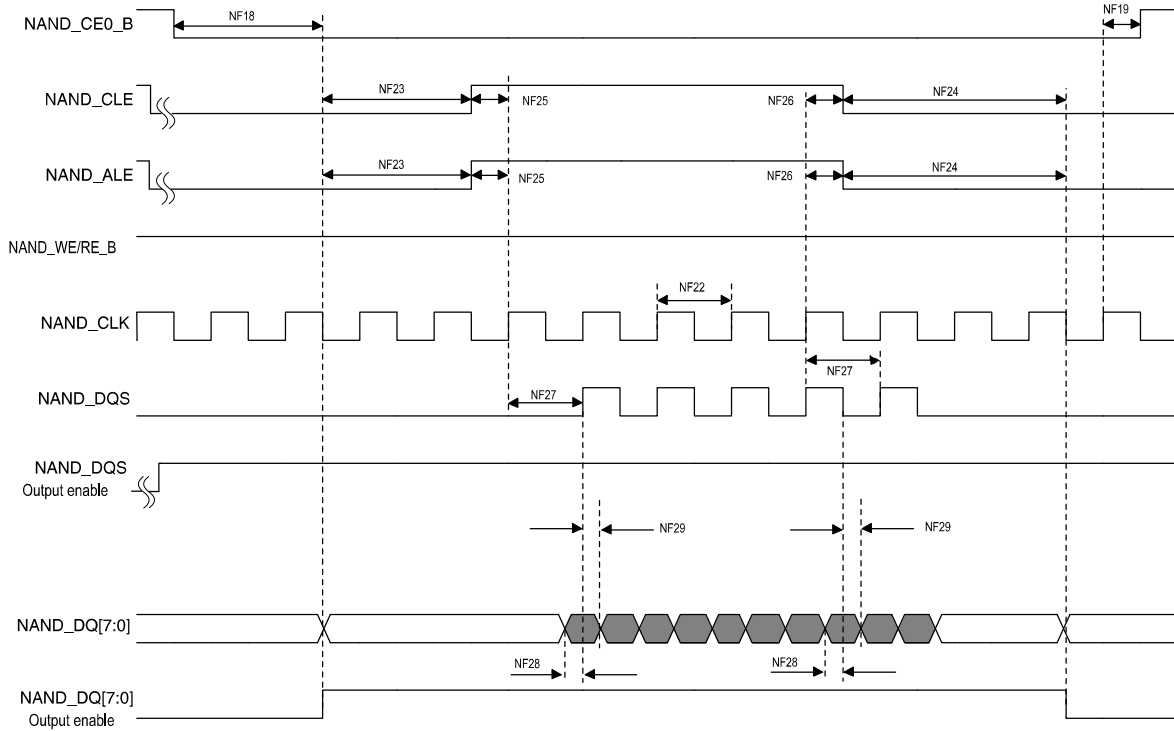

Figure 27. Source Synchronous mode data write timing diagram

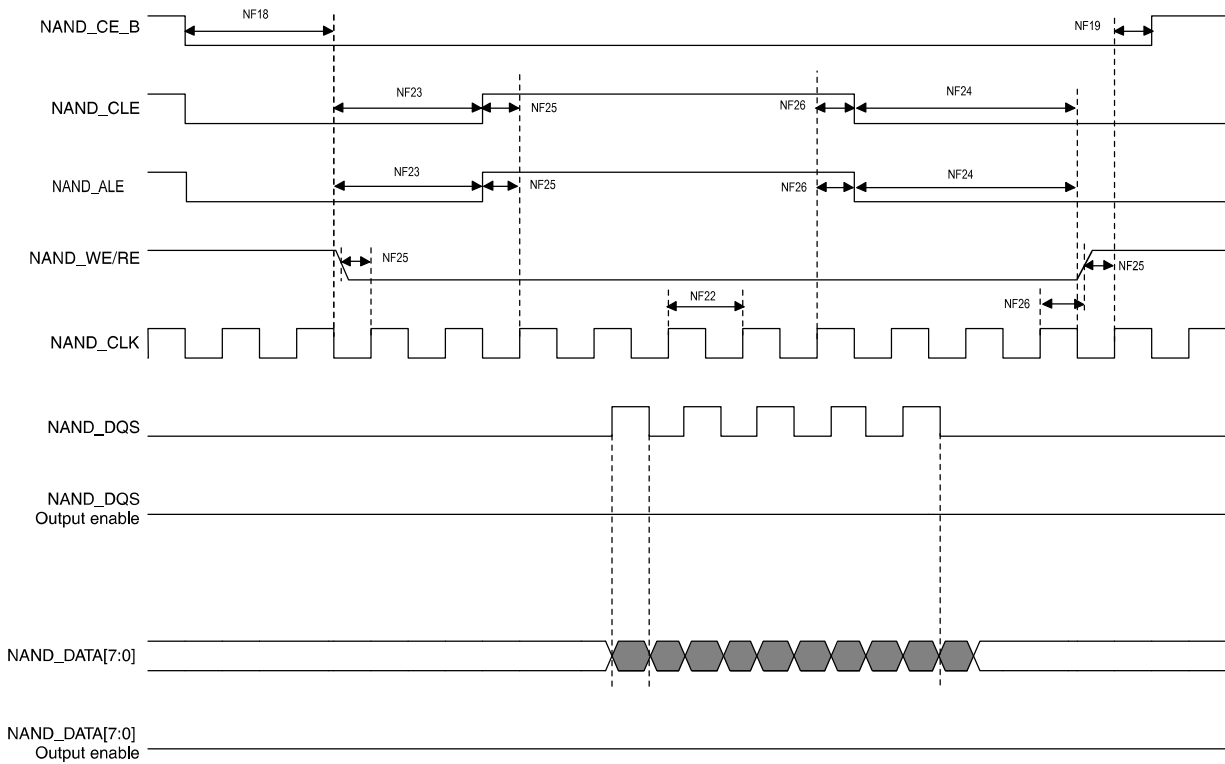

Figure 28. Source Synchronous mode data read timing diagram

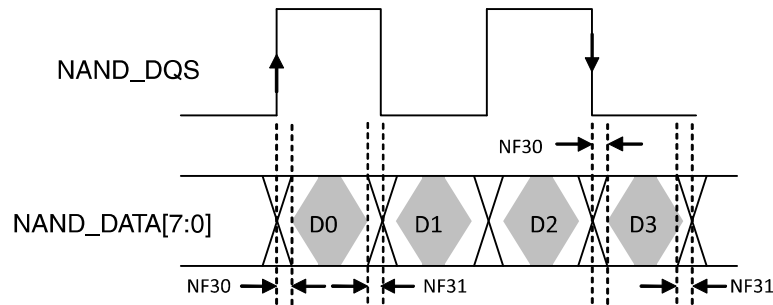

Figure 29. NAND_DQS/NAND_DQ read valid window

Table 50. Source Synchronous mode timing parameters¹

ID	Parameter	Symbol	Timing T = GPMI Clock Cycle		Unit
			Min.	Max.	
NF18	NAND_CE0_B access time	tCE	CE_DELAY × T - 0.79 [see note ²]		ns
NF19	NAND_CE0_B hold time	tCH	0.5 × tCK - 0.63 [see note ²]		ns
NF20	Command/address NAND_DATAxx setup time	tCAS	0.5 × tCK - 0.05		ns
NF21	Command/address NAND_DATAxx hold time	tCAH	0.5 × tCK - 1.23		ns
NF22	clock period	tCK	—		ns
NF23	preamble delay	tPRE	PRE_DELAY × T - 0.29 [see note ²]		ns
NF24	postamble delay	tPOST	POST_DELAY × T - 0.78 [see note ²]		ns
NF25	NAND_CLE and NAND_ALE setup time	tCALs	0.5 × tCK - 0.86		ns
NF26	NAND_CLE and NAND_ALE hold time	tCALH	0.5 × tCK - 0.37		ns
NF27	NAND_CLK to first NAND_DQS latching transition	tDQSS	T - 0.41 [see note ²]		ns
NF28	Data write setup	—	0.25 × tCK - 0.35		—
NF29	Data write hold	—	0.25 × tCK - 0.85		—
NF30	NAND_DQS/NAND_DQ read setup skew	—	—	2.06	—
NF31	NAND_DQS/NAND_DQ read hold skew	—	—	1.95	—

¹ GPMI's Source Synchronous mode output timing can be controlled by the module's internal registers GPMI_TIMING2_CE_DELAY, GPMI_TIMING2_PREAMBLE_DELAY, GPMI_TIMING2_POST_DELAY. This timing depends on these registers settings. In the table, CE_DELAY/PREAMBLE_DELAY/POST_DELAY represents each of these settings.

² T = tCK(GPMI clock period) - 0.075 ns (half of maximum p-p jitter).

For DDR Source Synchronous mode, Figure 29 shows the timing diagram of NAND_DQS/NAND_DATAxx read valid window. The typical value of tDQSS is 0.85 ns (max) and 1 ns (max) for tQHS at 200 MB/s. GPMI will sample NAND_DATA[7:0] at both rising and falling edge of an delayed NAND_DQS signal, which can be provided by an internal DPLL. The delay value can be controlled by GPMI register GPMI_READ_DDR_DLL_CTRL.SLV_DLY_TARGET (see the GPMI chapter of the *i.MX 8M Dual / 8M QuadLite / 8M Quad Applications Processor Reference Manual* [IMX8MDQLQRM]). Generally, the typical delay value of this register is equal to 0x7 which means 1/4 clock cycle delay expected. But if the board delay is big enough and cannot be ignored, the delay value should be made larger to compensate the board delay.

3.9.4.3 ONFI NV-DDR2 mode (ONFI 3.2 compatible)

3.9.4.3.1 Command and address timing

ONFI 3.2 mode command and address timing is the same as ONFI 1.0 compatible Async mode AC timing. See [Section 3.9.4.1, Asynchronous mode AC timing \(ONFI 1.0 compatible\)](#),” for details.

3.9.4.3.2 Read and write timing

ONFI 3.2 mode read and write timing is the same as Toggle mode AC timing. See [Section 3.9.4.4, Toggle mode AC Timing](#),” for details.

3.9.4.4 Toggle mode AC Timing

3.9.4.4.1 Command and address timing

NOTE

Toggle mode command and address timing is the same as ONFI 1.0 compatible Asynchronous mode AC timing. See [Section 3.9.4.1, Asynchronous mode AC timing \(ONFI 1.0 compatible\)](#),” for details.

3.9.4.4.2 Read and write timing

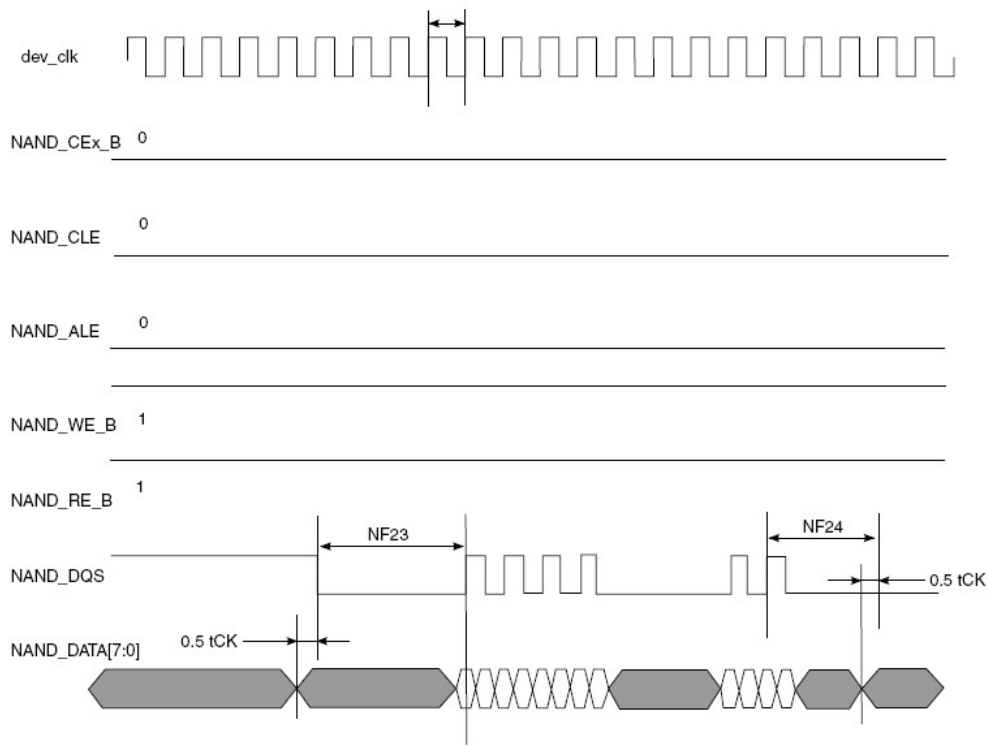

Figure 30. Toggle mode data write timing

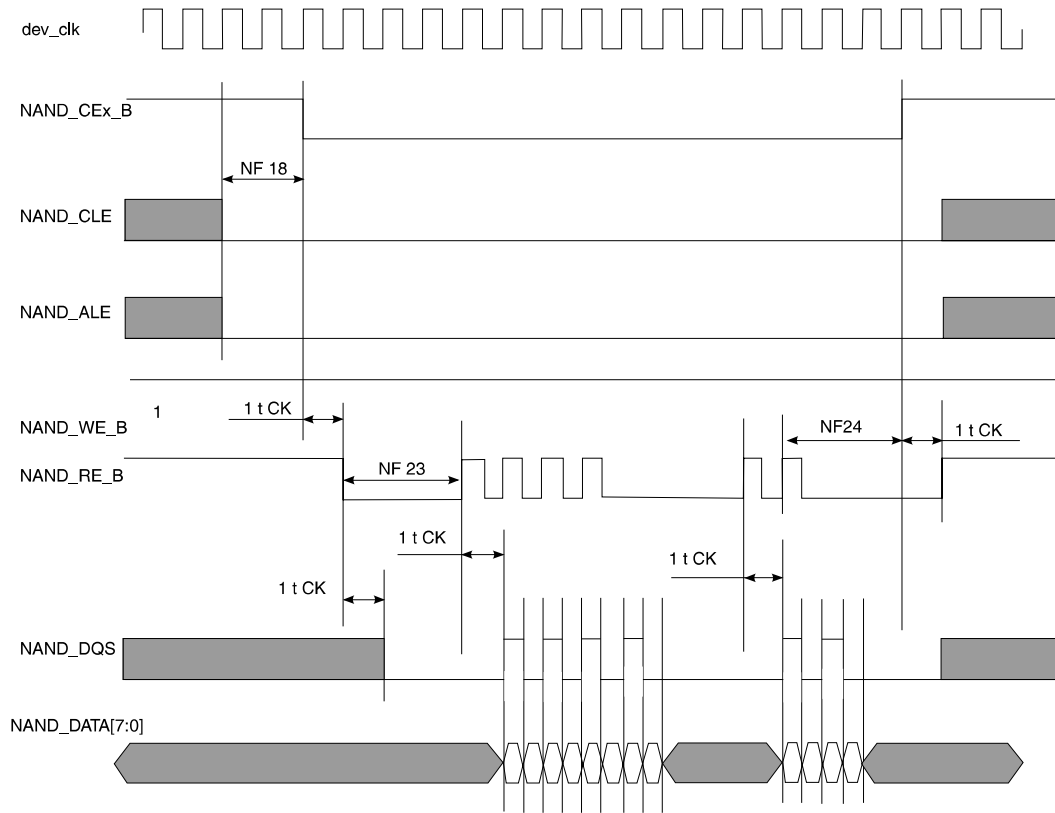

Figure 31. Toggle mode data read timing

Table 51. Toggle mode timing parameters¹

ID	Parameter	Symbol	Timing T = GPMI Clock Cycle		Unit
			Min.	Max.	
NF1	NAND_CLE setup time	tCLS	$(AS + DS) \times T - 0.12$ [see note ^{2,3}]		
NF2	NAND_CLE hold time	tCLH	$DH \times T - 0.72$ [see note ²]		
NF3	NAND_CE0_B setup time	tCS	$(AS + DS) \times T - 0.58$ [see notes ²]		
NF4	NAND_CE0_B hold time	tCH	$DH \times T - 1$ [see note ²]		
NF5	NAND_WE_B pulse width	tWP	$DS \times T$ [see note ²]		
NF6	NAND_ALE setup time	tALS	$(AS + DS) \times T - 0.49$ [see notes ²]		
NF7	NAND_ALE hold time	tALH	$DH \times T - 0.42$ [see note ²]		
NF8	Command/address NAND_DATAxx setup time	tCAS	$DS \times T - 0.26$ [see note ²]		
NF9	Command/address NAND_DATAxx hold time	tCAH	$DH \times T - 1.37$ [see note ²]		
NF18	NAND_CEx_B access time	tCE	$CE_DELAY \times T$ [see notes ^{4,2}]	—	ns
NF22	clock period	tCK	—	—	ns
NF23	preamble delay	tPRE	$PRE_DELAY \times T$ [see notes ^{5,2}]	—	ns

Table 51. Toggle mode timing parameters¹ (continued)

ID	Parameter	Symbol	Timing T = GPMI Clock Cycle		Unit
			Min.	Max.	
NF24	postamble delay	tPOST	POST_DELAY × T + 0.43 [see note ²]	—	ns
NF28	Data write setup	tDS ⁶	0.25 × tCK - 0.32	—	ns
NF29	Data write hold	tDH ⁶	0.25 × tCK - 0.79	—	ns
NF30	NAND_DQS/NAND_DQ read setup skew	tDQSQ ⁷	—	3.18	ns
NF31	NAND_DQS/NAND_DQ read hold skew	tQHS ⁷	—	3.27	ns

¹ The GPMI toggle mode output timing can be controlled by the module's internal registers HW_GPMI_TIMING0_ADDRESS_SETUP, HW_GPMI_TIMING0_DATA_SETUP, and HW_GPMI_TIMING0_DATA_HOLD. This AC timing depends on these register's settings. In the table, AS/DS/DH represents each of these settings.

² AS minimum value can be 0, while DS/DH minimum value is 1.

³ T = tCK (GPMI clock period) - 0.075 ns (half of maximum p-p jitter).

⁴ CE_DELAY represents HW_GPMI_TIMING2[CE_DELAY]. NF18 is guaranteed by the design. Read/Write operation is started with enough time of ALE/CLE assertion to low level.

⁵ PRE_DELAY+1 ≥ (AS+DS)

⁶ Shown in Figure 30.

⁷ Shown in Figure 31.

For DDR Toggle mode, Figure 29 shows the timing diagram of NAND_DQS/NAND_DATA_{xx} read valid window. The typical value of tDQSQ is 1.4 ns (max) and 1.4 ns (max) for tQHS at 133 MB/s. GPMI samples NAND_DATA[7:0] at both the rising and falling edges of a delayed NAND_DQS signal, which is provided by an internal DPLL. The delay value of this register can be controlled by the GPMI register GPMI_READ_DDR_DLL_CTRL.SLV_DLY_TARGET (see the GPMI chapter of the *i.MX 8M Dual / 8M QuadLite / 8M Quad Applications Processor Reference Manual* [IMX8MDQLQRM]). Generally, the typical delay value is equal to 0x7, which means a 1/4 clock cycle delay is expected. But if the board delay is big enough and cannot be ignored, the delay value should be made larger to compensate the board delay.

3.9.5 HDMI 2.0 Tx module timing parameters

See the following specifications:

- HDMI 2.0a specification (HDMI.org)
- DisplayPort 1.3 standard (VESA.org)
 - DP supports 1.6 GHz (RBR), 2.7 GHz (HBR), and 5.4 GHz (HBR2) rates. Those rates are managed in API (Host).
 - RBR supports 1080p60 (RGB 8b), HBR supports 4kp30 (RGB 8b) and HBR2 supports 4kp60 (RGB 8b).

See bandwidth details below.

Effective bandwidth per rate with 4 lanes:

— RBR: 1.62 × 4 × 8 / 10 = 5.184 Gbps

— HBR: 2.7 × 4 × 8 / 10 = 8.64 Gbps

- HBR2: $1.62 \times 4 \times 8 / 10 = 17.28$ Gbps
- Bandwidth required per resolution (CEA-861-F):
 - 1920 x 1080 (24 b/px) 60 fps: 3.56 Gbps
 - 3840 x 2160 (24 b/px) 30 fps: 7.13 Gbps
 - 3840 x 2160 (24 b/px) 30 fps: 14.26 Gbps
- Embedded DisplayPort 1.4 standard (VESA.org)
 - eDP link rates: R216 (2.16 Gbps), R243 (2.43 Gbps), R324 (3.24 Gbps), and R432 (4.32 Gbps)
 - Fast Link Training is also supported

DDC link requires external pull-up resistors to be connected to a 5 V supply. The following table provides the range for those pull-ups.

Table 52. Pull-up resistors for DDC link

Ball Name	Min	Typ	Max	Unit
HDMI_TX0_DDC_SCL	1.5	—	2	k Ω
HDMI_TX0_DDC_SDA	1.5	—	2	k Ω

3.9.6 I²C bus characteristics

The Inter-Integrated Circuit (I2C) provides functionality of a standard I2C master and slave. The I2C is designed to be compatible with the I2C Bus Specification, version 2.1, by Philips Semiconductor (now NXP Semiconductors).

3.9.7 MIPI D-PHY timing parameters

This section describes MIPI D-PHY electrical specifications.

3.9.7.1 MIPI HS-TX specifications

Table 53. MIPI high-speed transmitter DC specifications

Symbol	Parameter	Min	Typ	Max	Unit
V_{CMTX}^1	High Speed Transmit Static Common Mode Voltage	150	200	250	mV
$ \Delta V_{CMTX} _{(1,0)}$	V_{CMTX} mismatch when Output is Differential-1 or Differential-0	—	—	3	mV
$ V_{OD} ^1$	High Speed Transmit Differential Voltage	140	200	270	mV
$ \Delta V_{OD} $	V_{OD} mismatch when Output is Differential-1 or Differential-0	—	—	12	mV
V_{OHHS}^1	High Speed Output High Voltage	—	—	360	mV
Z_{OS}	Single Ended Output Impedance	40	50	62.5	Ω
ΔZ_{OS}	Single Ended Output Impedance Mismatch	—	—	10	%

¹ Value when driving into load impedance anywhere in the Z_{ID} range.

Electrical characteristics

Table 54. MIPI high-speed transmitter AC specifications

Symbol	Parameter	Min	Typ	Max	Unit
$\Delta V_{\text{CMTX(HF)}}$	Common-level variations above 450 MHz	—	—	8	mV _{RMS}
$\Delta V_{\text{CMTX(LF)}}$	Common-level variation between 50-450 MHz	—	—	10	mV _{PEAK}
t_R and t_F ¹	Rise Time and Fall Time (20% to 80%)	160	—	0.3 UI	ps

¹ UI is the long-term average unit interval.

3.9.7.2 MIPI LP-TX specifications

Table 55. MIPI low-power transmitter DC specifications

Symbol	Parameter	Min	Typ	Max	Unit
V_{OH} ¹	Thevenin Output High Level	1.1	1.2	1.3	V
V_{OL}	Thevenin Output Low Level	-50	—	50	mV
Z_{OLP} ²	Output Impedance of Low Power Transmitter	110	—	—	Ω

¹ This specification can only be met when limiting the core supply variation from 1.1 V to 1.3 V.

² Although there is no specified maximum for Z_{OLP} , the LP transmitter output impedance ensures the $T_{\text{RLP}}/T_{\text{FLP}}$ specification is met.

Table 56. MIPI low-power transmitter AC specifications

Symbol	Parameter	Min	Typ	Max	Unit
$T_{\text{RLP}}/T_{\text{FLP}}$ ¹	15% to 85% Rise Time and Fall Time	—	—	25	ns
T_{REOT} ^{1,2,3}	30% to 85% Rise Time and Fall Time	—	—	35	ns
$T_{\text{LP-PULSE-TX}}$ ⁴	Pulse width of the LP exclusive-OR clock: First LP exclusive-OR clock pulse after Stop state or last pulse before Stop state	40	—	—	ns
	Pulse width of the LP exclusive-OR clock: All other pulses	20	—	—	ns
$T_{\text{LP-PER-TX}}$	Period of the LP exclusive-OR clock	90	—	—	ns
$\delta V/\delta t_{\text{SR}}$ ^{1,5,6,7}	Slew Rate @ $C_{\text{LOAD}} = 0$ pF	30	—	500	mV/ns
	Slew Rate @ $C_{\text{LOAD}} = 5$ pF	30	—	200	mV/ns
	Slew Rate @ $C_{\text{LOAD}} = 20$ pF	30	—	150	mV/ns
	Slew Rate @ $C_{\text{LOAD}} = 70$ pF	30	—	100	mV/ns
C_{LOAD}	Load Capacitance	0	—	70	pF

¹ C_{LOAD} includes the low equivalent transmission line capacitance of TX and RX are assumed to always be < 10 pF. The distributed line capacitance can be up to 50 pF for a transmission line with 2 ns delay.

² The rise-time of T_{REOT} starts from the HS common-level at the moment when the differential amplitude drops below 70 mV, due to stopping of the differential drive.

³ With an additional load capacitance CCM between 0 to 60 pF on the termination center, tap at RX side of the lane.

⁴ This parameter value can be lower than TLPX, due to differences in rise vs. fall signal slopes, trip levels, and mismatches between Dp and Dn LP transmitters. Any LP exclusive-OR pulse observed during HS EoT (transition from HS level to LP-11) is glitch behavior as described in Low-Power Receiver section.

⁵ When the output voltage is between 15% and 85% of the fully settled LP signal levels.

⁶ Measured as average across any 50 mV segment of the output signal transition.

⁷ This value represents a corner point in a piecewise linear curve.

3.9.7.3 MIPI LP-RX specifications

Table 57. MIPI low power receiver DC specifications

Symbol	Parameter	Min	Typ	Max	Unit
V_{IH}	Logic 1 input voltage	880	—	1300	mV
V_{IL}	Logic 0 input voltage, not in ULP state	—	—	550	mV
$V_{IL-ULPS}$	Logic 0 input voltage, ULP state	—	—	300	mV
V_{HYST}	Input hysteresis	25	—	—	mV

Table 58. MIPI low power receiver AC specifications

Symbol	Parameter	Min	Typ	Max	Unit
$e_{SPIKE}^{1,2}$	Input pulse rejection	—	—	300	V.ps
T_{MIN-RX}^3	Minimum pulse width response	20	0	0	ns
V_{INT}	Peak Interference amplitude	—	—	200	mV
f_{INT}	Interference frequency	450	—	—	MHz

¹ Time-voltage integration of a spike above V_{IL} when in LP-0 state or below V_{IH} when in LP-1 state.

² An impulse below this value will not change the receiver state.

³ An input pulse greater than this value shall toggle the output.

3.9.7.4 MIPI LP-CD specifications

Table 59. MIPI contention detector DC specifications

Symbol	Parameter	Min	Typ	Max	Unit
V_{IHCD}	Logic 1 contention threshold	450	—	—	mV
V_{ILCD}	Logic 0 contention threshold	—	—	200	mV

3.9.7.5 MIPI DC specifications

Table 60. MIPI input characteristics DC specifications

Symbol	Parameter	Min	Typ	Max	Unit
V_{PIN}	Pad signal voltage range	-50	—	1350	mV
I_{LEAK}^1	Pin leakage current	-30	—	30	μ A
V_{GNDSH}	Ground shift	-50	—	50	mV

Electrical characteristics

Table 60. MIPI input characteristics DC specifications (continued)

$V_{PIN(absmax)}^2$	Maximum pin voltage level	-0.15	—	1.45	V
$T_{VPIN(absmax)}^3$	Maximum transient time above $V_{PIN(max)}$ or below $V_{PIN(min)}$	—	—	20	ns

¹ When the pad voltage is within the signal voltage range between $V_{GNDSh(min)}$ to $V_{OH} + V_{GNDSh(max)}$ and the Lane Module is in LP receive mode.

² This value includes ground shift.

³ The voltage overshoot and undershoot beyond the V_{PIN} is only allowed during a single 20 ns window after any LP-0 to LP-1 transition or vice versa. For all other situations it must stay within the V_{PIN} range.

3.9.8 PCIe PHY parameters

The PCIe interface is designed to be compatible with PCIe specification Gen2 x1 lane and supports the PCI Express 1.1/2.0 standard.

3.9.8.1 PCIe_{EX}_RESREF reference resistor connection

The impedance calibration process requires connection of reference resistor 200 Ω . 1% precision resistor on PCIe_{EX}_RESREF pads to ground. It is used for termination impedance calibration.

3.9.9 Pulse width modulator (PWM) timing parameters

This section describes the electrical information of the PWM. The PWM can be programmed to select one of three clock signals as its source frequency. The selected clock signal is passed through a prescaler before being input to the counter. The output is available at the pulse-width modulator output (PWMO) external pin.

Figure 32 depicts the timing of the PWM, and Table 61 lists the PWM timing parameters.

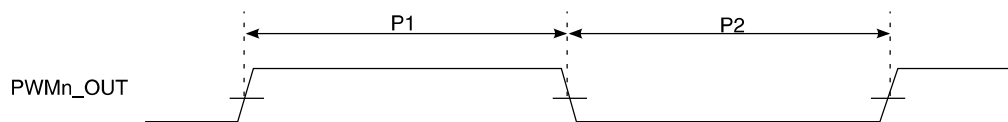

Figure 32. PWM timing

Table 61. PWM output timing parameters

ID	Parameter	Min	Max	Unit
	PWM Module Clock Frequency	0	ipg_clk (66 MHz)	MHz
P1	PWM output pulse width high	15	—	ns
P2	PWM output pulse width low	15	—	ns

3.9.10 Quad SPI (QSPI) timing parameters

This section describes the electrical information for QSPI.

Measurement is with a load of 35 pF on SCK and SIO pins and an input slew rate of 1 V/ns.

3.9.10.1 SDR Mode

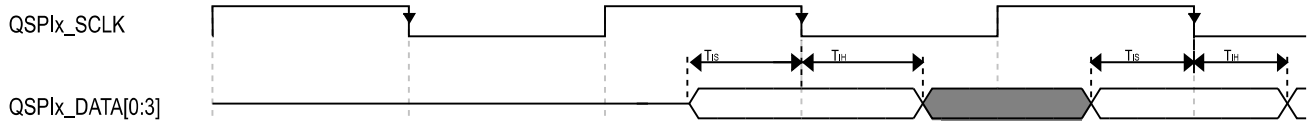

Figure 33. QuadSPI input/read timing (SDR mode with internal sampling)

Table 62. QuadSPI input timing (SDR mode with internal sampling)

Symbol	Parameter	Value		Unit
		Min	Max	
T_{IS}	Setup time for incoming data	8.67	—	ns
T_{IH}	Hold time requirement for incoming data	0	—	ns

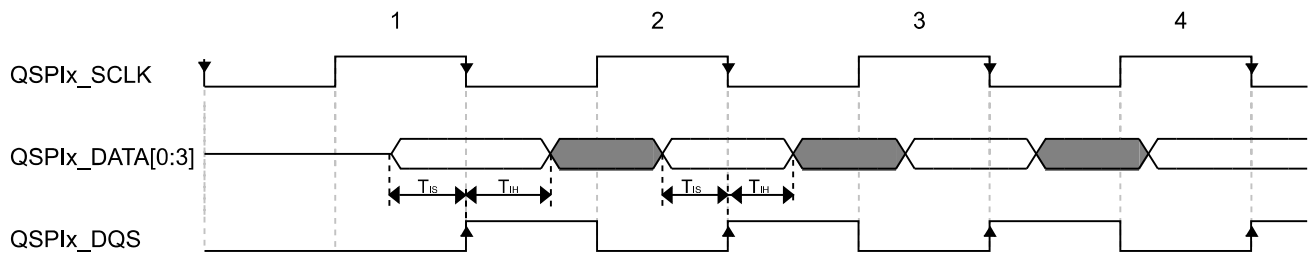

Figure 34. QuadSPI input/read timing (SDR mode with loopback DQS sampling)

Table 63. QuadSPI input/read timing (SDR mode with loopback DQS sampling)

Symbol	Parameter	Value		Unit
		Min	Max	
T_{IS}	Setup time for incoming data	2	—	ns
T_{IH}	Hold time requirement for incoming data	1	—	ns

NOTE

- For internal sampling, the timing values assume using sample point 0, that is $QuadSPIx_SMPR[SDRSMP] = 0$.

Electrical characteristics

- For loopback DQS sampling, the data strobe is output to the DQS pad together with the serial clock. The data strobe is looped back from DQS pad and used to sample input data.

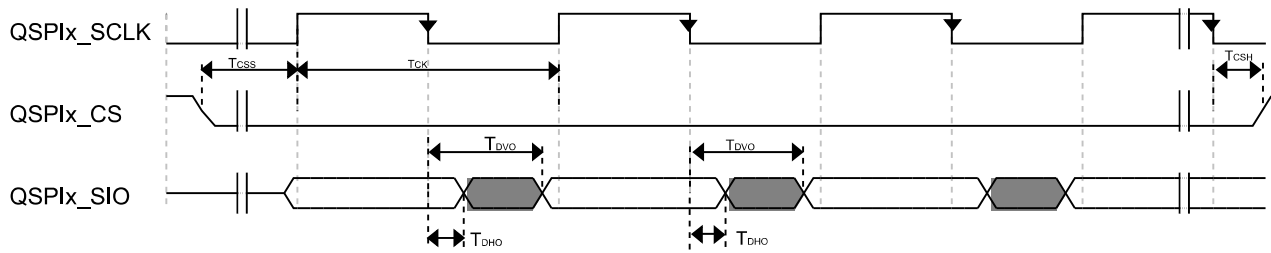

Figure 35. QuadSPI output/write timing (SDR mode)

Table 64. QuadSPI output/write timing (SDR mode)

Symbol	Parameter	Value		Unit
		Min	Max	
T_{DVO}	Output data valid time	—	2	ns
T_{DHO}	Output data hold time	-0.5	—	ns
T_{CK}	SCK clock period	10	—	ns
T_{CSS}	Chip select output setup time	3	—	ns
T_{CSH}	Chip select output hold time	3	—	ns

NOTE

T_{css} and T_{csh} are configured by the QuadSPIx_FLSHCR register; the default value of 3 is shown on the timing. See the *i.MX 8M Dual / 8M QuadLite / 8M Quad Applications Processor Reference Manual (IMX8MDQLQRM)* for more details.

3.9.10.2 DDR mode

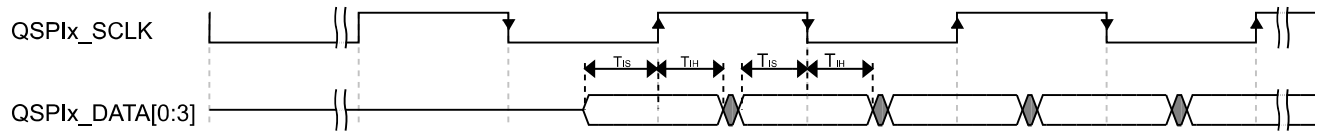

Figure 36. QuadSPI input/read timing (DDR mode with internal sampling)

Table 65. QuadSPI input/read timing (DDR mode with internal sampling)

Symbol	Parameter	Value		Unit
		Min	Max	
T_{IS}	Setup time for incoming data	8.67	—	ns
T_{IH}	Hold time requirement for incoming data	0	—	ns

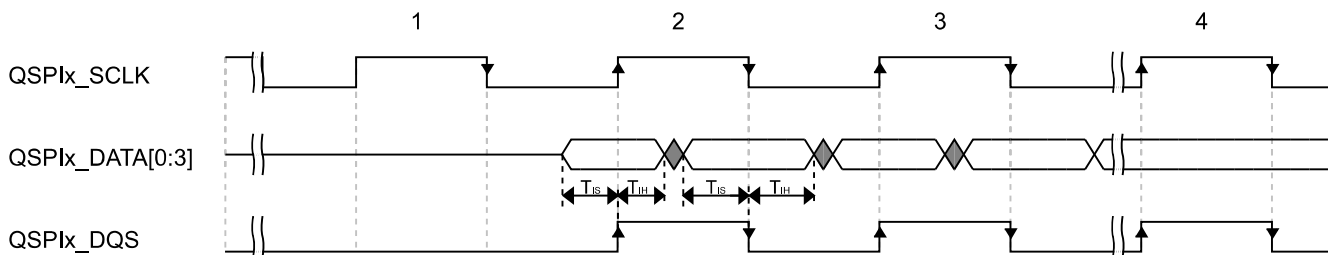

Figure 37. QuadSPI input/read timing (DDR mode with loopback DQS sampling)

Table 66. QuadSPI input/read timing (DDR mode with loopback DQS sampling)

Symbol	Parameter	Value		Unit
		Min	Max	
T_{IS}	Setup time for incoming data	2	—	ns
T_{IH}	Hold time requirement for incoming data	1	—	ns

NOTE

- For internal sampling, the timing values assume using sample point 0, that is $\text{QuadSPIx_SMPr}[\text{SDRSMP}] = 0$.

Electrical characteristics

- For loopback DQS sampling, the data strobe is output to the DQS pad together with the serial clock. The data strobe is looped back from DQS pad and used to sample input data.

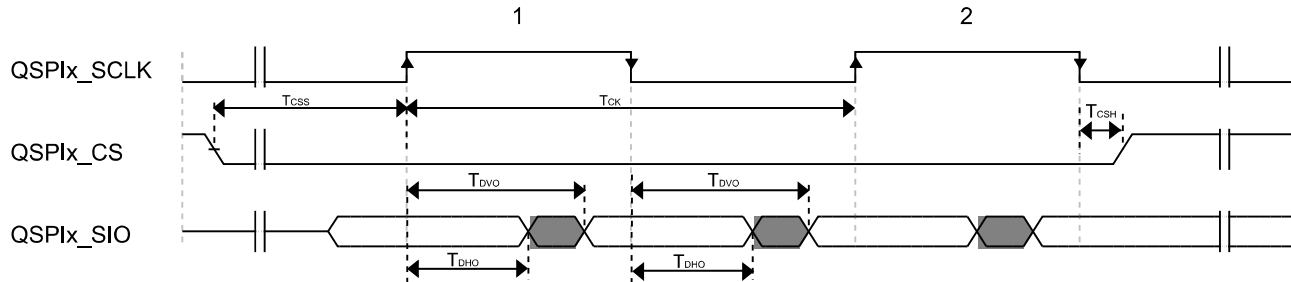

Figure 38. QuadSPI output/write timing (DDR mode)

Table 67. QuadSPI output/write timing (DDR mode)

Symbol	Parameter	Value		Unit
		Min	Max	
T_{DVO}	Output data valid time	—	$(0.25 \times T_{SCLK}) + 2$	ns
T_{DHO}	Output data hold time	$(0.25 \times T_{SCLK}) - 0.5$	—	ns
T_{CK}	SCK clock period	20	—	ns
T_{CSS}	Chip select output setup time	3	—	SCK cycle(s)
T_{CSH}	Chip select output hold time	3	—	ns

NOTE

T_{CSS} and T_{CSH} are configured by the QuadSPIx_FLSHCR register; the default value of 3 is shown on the timing. See the *i.MX 8M Dual / 8M QuadLite / 8M Quad Applications Processor Reference Manual (IMX8MDQLQRM)* for more details.

3.9.11 SAI/I2S switching specifications

This section provides the AC timings for the SAI in Master (clocks driven) and Slave (clocks input) modes. All timings are given for non inverted serial clock polarity (SAI_TCR[TSCKP] = 0, SAI_RCR[RSCKP] = 0) and non inverted frame sync (SAI_TCR[TFSI] = 0, SAI_RCR[RFSI] = 0). If the polarity of the clock and/or the frame sync have been inverted, all the timings remain valid by inverting the clock signal (SAI_BCLK) and/or the frame sync (SAI_FS) shown in the figures below.

Table 68. Master mode SAI timing

Num	Characteristic	Min	Max	Unit
S1	SAI_MCLK cycle time	20	—	ns
S2	SAI_MCLK pulse width high/low	40%	60%	MCLK period
S3	SAI_BCLK cycle time	40	—	ns

Table 68. Master mode SAI timing (continued)

Num	Characteristic	Min	Max	Unit
S4	SAI_BCLK pulse width high/low	40%	60%	BCLK period
S5	SAI_BCLK to SAI_FS output valid	—	15	ns
S6	SAI_BCLK to SAI_FS output invalid	0	—	ns
S7	SAI_BCLK to SAI_TXD valid	—	15	ns
S8	SAI_BCLK to SAI_TXD invalid	0	—	ns
S9	SAI_RXD/SAI_FS input setup before SAI_BCLK	15	—	ns
S10	SAI_RXD/SAI_FS input hold after SAI_BCLK	0	—	ns

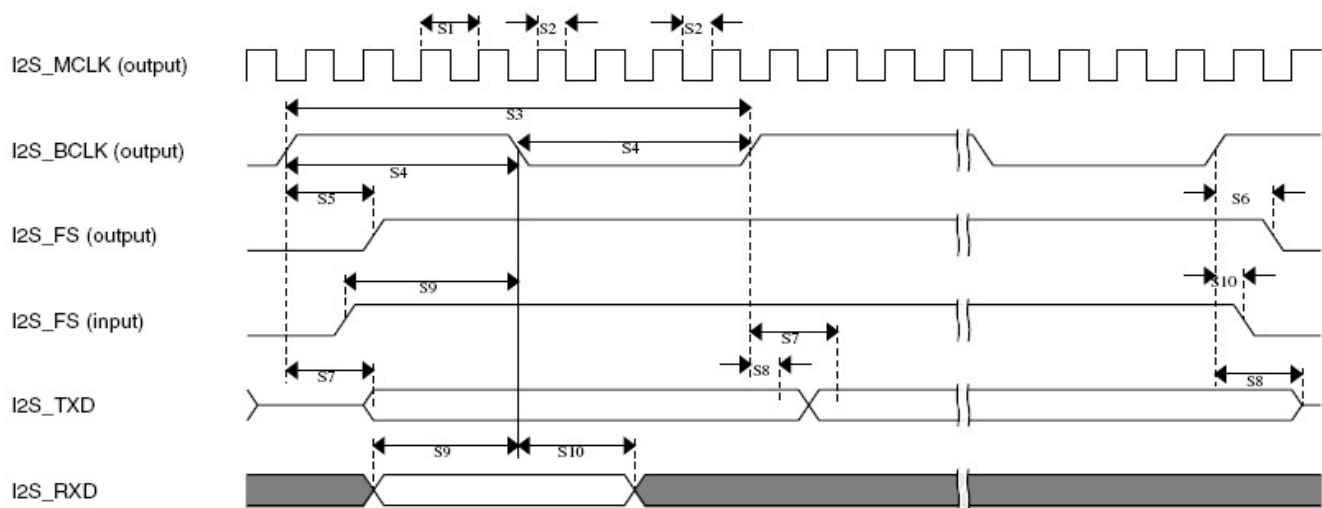

Figure 39. SAI timing—Master modes

Table 69. Slave mode SAI timing

Num	Characteristic	Min	Max	Unit
S11	SAI_BCLK cycle time (input)	40	—	ns
S12	SAI_BCLK pulse width high/low (input)	40%	60%	BCLK period
S13	SAI_FS input setup before SAI_BCLK	10	—	ns
S14	SAI_FA input hold after SAI_BCLK	2	—	ns
S15	SAI_BCLK to SAI_TXD/SAI_FS output valid	—	20	ns
S16	SAI_BCLK to SAI_TXD/SAI_FS output invalid	0	—	ns
S17	SAI_RXD setup before SAI_BCLK	10	—	ns
S18	SAI_RXD hold after SAI_BCLK	2	—	ns

Electrical characteristics

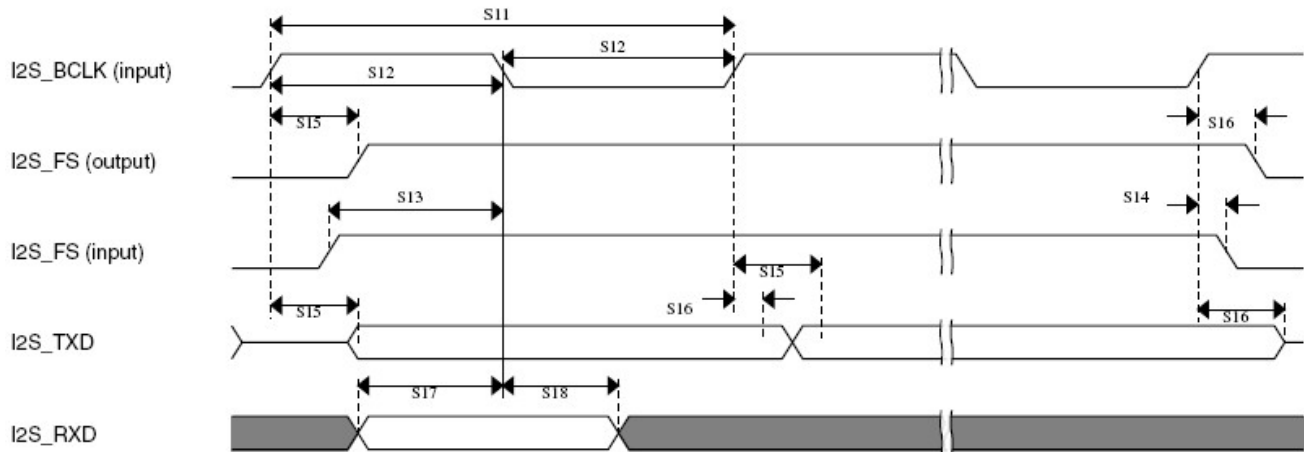

Figure 40. SAI Timing — Slave Modes

3.9.12 SPDIF timing parameters

The Sony/Philips Digital Interconnect Format (SPDIF) data is sent using the bi-phase marking code. When encoding, the SPDIF data signal is modulated by a clock that is twice the bit rate of the data signal.

Table 70 and Figure 41 and Figure 42 show SPDIF timing parameters for the Sony/Philips Digital Interconnect Format (SPDIF), including the timing of the modulating Rx clock (SPDIF_SR_CLK) for SPDIF in Rx mode and the timing of the modulating Tx clock (SPDIF_ST_CLK) for SPDIF in Tx mode.

Table 70. SPDIF timing parameters

Parameter	Symbol	Timing Parameter Range		Unit
		Min	Max	
SPDIF_IN Skew: asynchronous inputs, no specs apply	—	—	0.7	ns
SPDIF_OUT output (Load = 50 pf)				
• Skew	—	—	1.5	ns
• Transition rising	—	—	24.2	
• Transition falling	—	—	31.3	
SPDIF_OUT output (Load = 30 pf)				
• Skew	—	—	1.5	ns
• Transition rising	—	—	13.6	
• Transition falling	—	—	18.0	
Modulating Rx clock (SPDIF_SR_CLK) period	srckp	40.0	—	ns
SPDIF_SR_CLK high period	srckph	16.0	—	ns
SPDIF_SR_CLK low period	srckpl	16.0	—	ns
Modulating Tx clock (SPDIF_ST_CLK) period	stckp	40.0	—	ns
SPDIF_ST_CLK high period	stckph	16.0	—	ns
SPDIF_ST_CLK low period	stckpl	16.0	—	ns

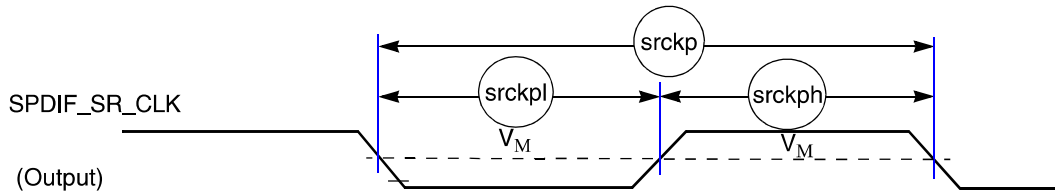

Figure 41. SPDIF_SR_CLK timing diagram

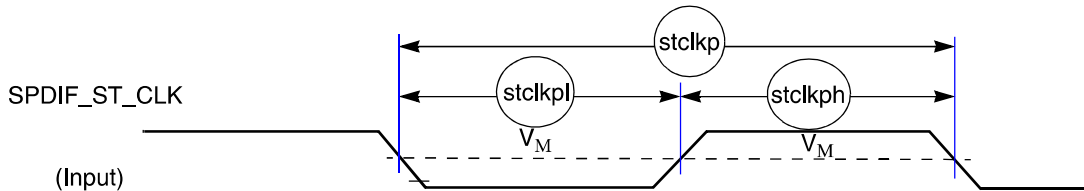

Figure 42. SPDIF_ST_CLK timing diagram

3.9.13 UART I/O configuration and timing parameters

3.9.13.1 UART RS-232 I/O configuration in different modes

The UART interfaces of the i.MX 8M Dual / 8M QuadLite / 8M Quad processors can serve both as DTE or DCE device. This can be configured by the DCEDTE control bit (default 0—DCE mode). [Table 71](#) shows the UART I/O configuration based on the enabled mode.

Table 71. UART I/O configuration vs. mode

Port	DTE Mode		DCE Mode	
	Direction	Description	Direction	Description
UARTx_RTS_B	Output	UARTx_RTS_B from DTE to DCE	Input	UARTx_RTS_B from DTE to DCE
UARTx_CTS_B	Input	UARTx_CTS_B from DCE to DTE	Output	UARTx_CTS_B from DCE to DTE
UARTx_TX_DATA	Input	Serial data from DCE to DTE	Output	Serial data from DCE to DTE
UARTx_RX_DATA	Output	Serial data from DTE to DCE	Input	Serial data from DTE to DCE

3.9.13.2 UART RS-232 Serial mode timing

This section describes the electrical information of the UART module in the RS-232 mode.

3.9.13.2.1 UART transmitter

Figure 43 depicts the transmit timing of UART in the RS-232 Serial mode, with 8 data bit/1 stop bit format. Table 72 lists the UART RS-232 Serial mode transmit timing characteristics.

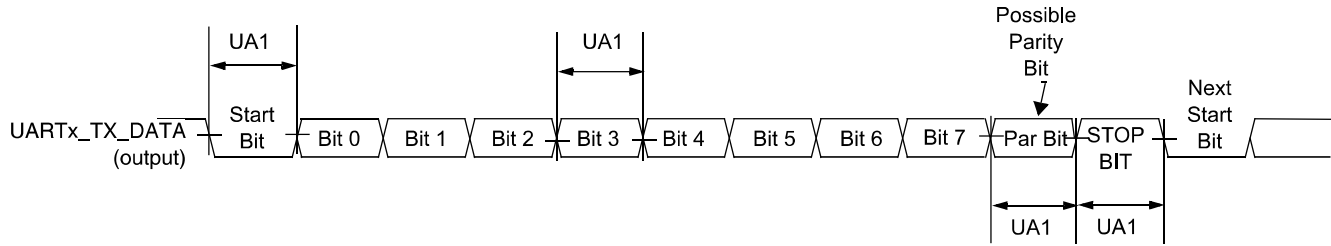

Figure 43. UART RS-232 Serial mode transmit timing diagram

Table 72. RS-232 Serial mode transmit timing parameters

ID	Parameter	Symbol	Min	Max	Unit
UA1	Transmit Bit Time	t_{Tbit}	$1/F_{baud_rate}^1 - T_{ref_clk}^2$	$1/F_{baud_rate} + T_{ref_clk}$	—

¹ F_{baud_rate} : Baud rate frequency. The maximum baud rate the UART can support is $(ipg_perclk \text{ frequency})/16$.

² T_{ref_clk} : The period of UART reference clock ref_clk (ipg_perclk after RFDIV divider).

3.9.13.2.2 UART receiver

Figure 44 depicts the RS-232 Serial mode receive timing with 8 data bit/1 stop bit format. Table 73 lists Serial mode receive timing characteristics.

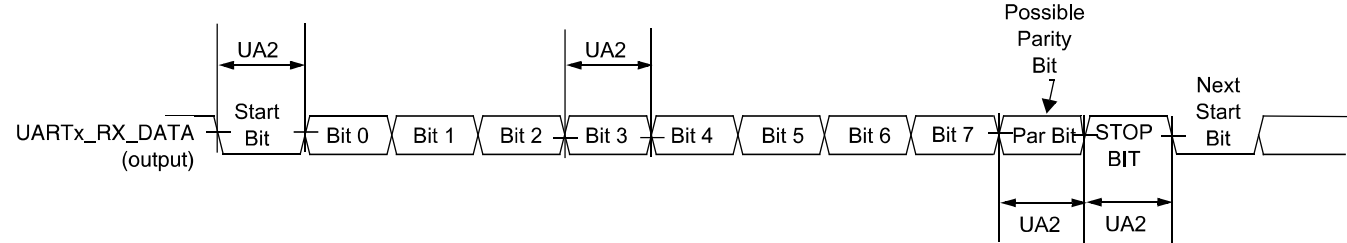

Figure 44. UART RS-232 Serial mode receive timing diagram

Table 73. RS-232 Serial mode receive timing parameters

ID	Parameter	Symbol	Min	Max	Unit
UA2	Receive Bit Time ¹	t_{Rbit}	$1/F_{baud_rate}^2 - 1/(16 \times F_{baud_rate})$	$1/F_{baud_rate} + 1/(16 \times F_{baud_rate})$	—

¹ The UART receiver can tolerate $1/(16 \times F_{baud_rate})$ tolerance in each bit. But accumulation tolerance in one frame must not exceed $3/(16 \times F_{baud_rate})$.

² F_{baud_rate} : Baud rate frequency. The maximum baud rate the UART can support is $(ipg_perclk \text{ frequency})/16$.

3.9.14 USB PHY parameters

This section describes the USB-OTG PHY parameters.

The USB PHY meets the electrical compliance requirements defined in the Universal Serial Bus Revision 3.0 OTG, USB Host with the amendments below (On-The-Go and Embedded Host Supplement to the USB Revision 3.0 Specification is not applicable to Host port):

- USB ENGINEERING CHANGE NOTICE
 - Title: 5V Short Circuit Withstand Requirement Change
 - Applies to: Universal Serial Bus Specification, Revision 2.0
- Errata for USB Revision 2.0 April 27, 2000 as of 12/7/2000
- USB ENGINEERING CHANGE NOTICE
 - Title: Pull-up/Pull-down resistors
 - Applies to: Universal Serial Bus Specification, Revision 2.0
- USB ENGINEERING CHANGE NOTICE
 - Title: Suspend Current Limit Changes
 - Applies to: Universal Serial Bus Specification, Revision 2.0
- USB ENGINEERING CHANGE NOTICE
 - Title: USB 2.0 Phase Locked SOFs
 - Applies to: Universal Serial Bus Specification, Revision 2.0
- On-The-Go and Embedded Host Supplement to the USB Revision 2.0 Specification
 - Revision 2.0, version 1.1a, July 27, 2010
- Battery Charging Specification (available from USB-IF)
 - Revision 1.2, December 7, 2010

3.9.14.1 USB_OTG*_REXT reference resistor connection

The bias generation and impedance calibration process for the USB OTG PHYs requires connection of reference resistors 200 Ω 1% precision on each of USB_OTG1_REXT and USB_OTG2_REXT pads to ground.

3.9.15 USB 2.0 PHY parameters

USB 2.0 PHY parameters are compatible with USB 3.0 PHY. See [Section 3.9.16, USB 3.0 PHY parameters](#) for more detailed information.

3.9.16 USB 3.0 PHY parameters

This section describes the electrical information about USB 3.0 PHY.

[Table 74](#) shows the USB 3.0 PHY junction temperature.

Electrical characteristics

Table 74. USB 3.0 PHY junction temperature

Min	Max
-40 °C	125 °C

Table 75 shows the USB 3.0 PHY power dissipation of SuperSpeed 5-Gbps operation.

Table 75. USB 3.0 PHY power dissipation: SuperSpeed 5-Gbps operation (unit: for current is mA, for power is mW)

Mode	Conditions	Current from USB1/2_VP	Current from USB1/2_VPTX	Current from USB1/2_VPH	Total Current	Total Power
U0	TT/WC	25.700/35.700	15.000/21.200	14.000/20.300	54.700/77.200	82.800/130.000
Power-Down	TT/WC	0.318/2.550	0.012/0.184	0.012/0.030	0.34/2.764	0.337/2.816

Table 76 shows the USB 3.0 PHY power dissipation: HS/FS/LS operation.

Table 76. USB 3.0 PHY power dissipation: HS/FS/LS operations (unit: for current is mA, for power is mW)

Mode	Conditions	Current from USB1/2_DVDD	Current from USB1/2_VDD33	Total Current	Total Power
HS TX	TT/WC	4.800/9.200	24.000/24.400	28.800/33.600	83.500/97.700
FS TX	TT/WC	2.800/6.800	22.100/24.500	24.900/31.200	75.400/95.500
LS TX	TT/WC	3.500/7.700	19.300/20.400	22.800/28.100	66.900/81.700
Power-Down	TT/WC	0.048/3.690	0.065/0.146	0.112/3.386	0.257/4.182
Suspend	TT/WC	0.047/3.690	0.066/0.154	0.113/3.844	0.261/4.213
Battery Charging	TT/WC	0.122/3.760	6.350/5.780	6.472/9.540	21.065/24.704

Table 77 shows the worst-case maximum current.

Table 77. Worst-Case maximum current

USB1/2_VPH	USB1/2_VP	USB1/2_VPTX	USB1/2_VDD33	USB1/2_DVDD	Unit
20.3	35.7	21.2	24.5	9.2	mA

Table 78 shows the USB power pin supplies.

Table 78. USB power pin supplies

Pin Name	Description	Value
USB1/2_VDD	PHY analog and digital high-speed supply	0.9 V (+22.2%, -7%)
USB1/2_VP	PHY analog and digital SuperSpeed supply	0.9 V (+22.2%, -7%)
USB1/2_VPTX	PHY transmit supply	0.9 V (+22.2%, -7%)
USB1/2_VDD33	High supply for high-speed operation IO	3.3 V (+10%, -7%)
USB1/2_VPH	High supply for SuperSpeed operation IO	3.3 V (+10%, -7%)

Table 79 shows the external component values.

Table 79. External component values

Component	Pin Name	Value
External resistor (resref)	USB1_RESREF/USB2_RESREF	200 Ω ($\pm 1\%$)

Table 80 shows the minimum ESD protection target levels.

Table 80. Minimum ESD protection target levels

ESD Category	Minimum Protection Level	JEDEC Class
Human Body Model (HBM) (JS-001-2014)	2 KV	2
Charged Device Model (CDM) (JESD22-C101F)	6 A peak discharge current	C2/C1 (500 V/ 250 V) ¹
Machine Model (MM) (JESD22_A115C)	100 V	N/A

¹ Support for either 500 V or 250 V CDM target level is dependent on maximum discharge current generated in final SoC/package implementation.

Table 81 shows the supply impedance requirements.

Table 81. Supply impedance requirements

$L_{gd} + L_{vp}(nH)$	$L_{VSSA<\#>} + L_{DVDD}(nH)$	$L_{gd} + L_{vptx<\#>}(nH)$	$L_{VSSA<\#>} + L_{VDD33<\#>}(nH)$	$L_{gd} + L_{vph}(nH)$
< 2.4	< 2.4	< 2.4	< 2.8	< 2.8

4 Boot mode configuration

This section provides information on Boot mode configuration pins allocation and boot devices interfaces allocation.

4.1 Boot mode configuration pins

Table 82 provides boot options, functionality, fuse values, and associated pins. Several input pins are also sampled at reset and can be used to override fuse values, depending on the value of BT_FUSE_SEL fuse. The boot option pins are in effect when BT_FUSE_SEL fuse is '0' (cleared, which is the case for an unblown fuse). For detailed Boot mode options configured by the Boot mode pins, see the “System Boot, Fusemap, and eFuse” chapter in the *i.MX 8M Dual / 8M QuadLite / 8M Quad Applications Processor Reference Manual (IMX8MDQLQRM)*.

Table 82. Fuses and associated pins used for boot

Pin	Direction at Reset	eFuse name	State during reset (POR_B asserted)	State after reset (POR_B deasserted)	Details
BOOT_MODE0	Input	N/A	Input with 95 K pull down	Input with 95 K pull down	Boot mode selection
BOOT_MODE1	Input	N/A	Input with 95 K pull down	Input with 95 K pull down	Boot mode selection
SAI1_RXD0	Input	BOOT_CFG[0]	Input with 95 K pull down	Input with 95 K pull down	Boot options pin value overrides fuse settings for BT_FUSE_SEL = "0". Signal configuration as fuse override input at power up. These are special I/O lines that control the boot configuration during product development. In production, the boot configuration can be controlled by fuses.
SAI1_RXD1	Input	BOOT_CFG[1]	Input with 95 K pull down	Input with 95 K pull down	
SAI1_RXD2	Input	BOOT_CFG[2]	Input with 95 K pull down	Input with 95 K pull down	
SAI1_RXD3	Input	BOOT_CFG[3]	Input with 95 K pull down	Input with 95 K pull down	
SAI1_RXD4	Input	BOOT_CFG[4]	Input with 95 K pull down	Input with 95 K pull down	
SAI1_RXD5	Input	BOOT_CFG[5]	Input with 95 K pull down	Input with 95 K pull down	
SAI1_RXD6	Input	BOOT_CFG[6]	Input with 95 K pull down	Input with 95 K pull down	
SAI1_RXD7	Input	BOOT_CFG[7]	Input with 95 K pull down	Input with 95 K pull down	
SAI1_TXD0	Input	BOOT_CFG[8]	Input with 95 K pull down	Input with 95 K pull down	
SAI1_TXD1	Input	BOOT_CFG[9]	Input with 95 K pull down	Input with 95 K pull down	
SAI1_TXD2	Input	BOOT_CFG[10]	Input with 95 K pull down	Input with 95 K pull down	
SAI1_TXD3	Input	BOOT_CFG[11]	Input with 95 K pull down	Input with 95 K pull down	
SAI1_TXD4	Input	BOOT_CFG[12]	Input with 95 K pull down	Input with 95 K pull down	
SAI1_TXD5	Input	BOOT_CFG[13]	Input with 95 K pull down	Input with 95 K pull down	
SAI1_TXD6	Input	BOOT_CFG[14]	Input with 95 K pull down	Input with 95 K pull down	
SAI1_TXD7	Input	BOOT_CFG[15]	Input with 95 K pull down	Input with 95 K pull down	

4.2 Boot device interface allocation

Table 83 lists the interfaces that can be used by the boot process in accordance with the specific Boot mode configuration. The table also describes the interface's specific modes and IOMUXC allocation, which are configured during boot when appropriate.

Table 83. Interface allocation during boot

Interface	IP Instance	Allocated Pads During Boot	Comment
NAND Flash	GPMI	NAND_ALE, NAND_CE0_B, NAND_CLE, NAND_DATA00, NAND_DATA01, NAND_DATA02, NAND_DATA03, NAND_DATA04, NAND_DATA05, NAND_DATA06, NAND_DATA07, NAND_DQS, NAND_RE_B, NAND_READY_B, NAND_WE_B, NAND_WP_B	8-bit, only CS0 is supported.
SD/MMC	USDHC-1	GPIO1_IO03, GPIO1_IO06, GPIO1_IO07, SD1_RESET_B, SD1_CLK, SD1_CMD, SD1_STROBE, SD1_DATA0, SD1_DATA1, SD1_DATA2,SD1_DATA3,SD1_DATA4,SD1_DATA5, SD1_DATA6, SD1_DATA7	1, 4, or 8-bit
SD/MMC	USDHC-2	GPIO1_IO04, GPIO1_IO08, GPIO1_IO07, SD2_RESET_B, SD2_CD_B, SD2_WP, SD2_CLK, SD2_CMD, SD2_DATA0, SD2_DATA1, SD2_DATA2, SD2_DATA3	1 or 4-bit
USB	USB_OTG PHY	—	—

5 Package information and contact assignments

This section includes the contact assignment information and mechanical package drawing.

5.1 17 x 17 mm package information

5.1.1 17 x 17 mm, 0.65 mm pitch, ball matrix

[Figure 45](#) shows the top, bottom, and side views of the 17 × 17 mm BGA package.

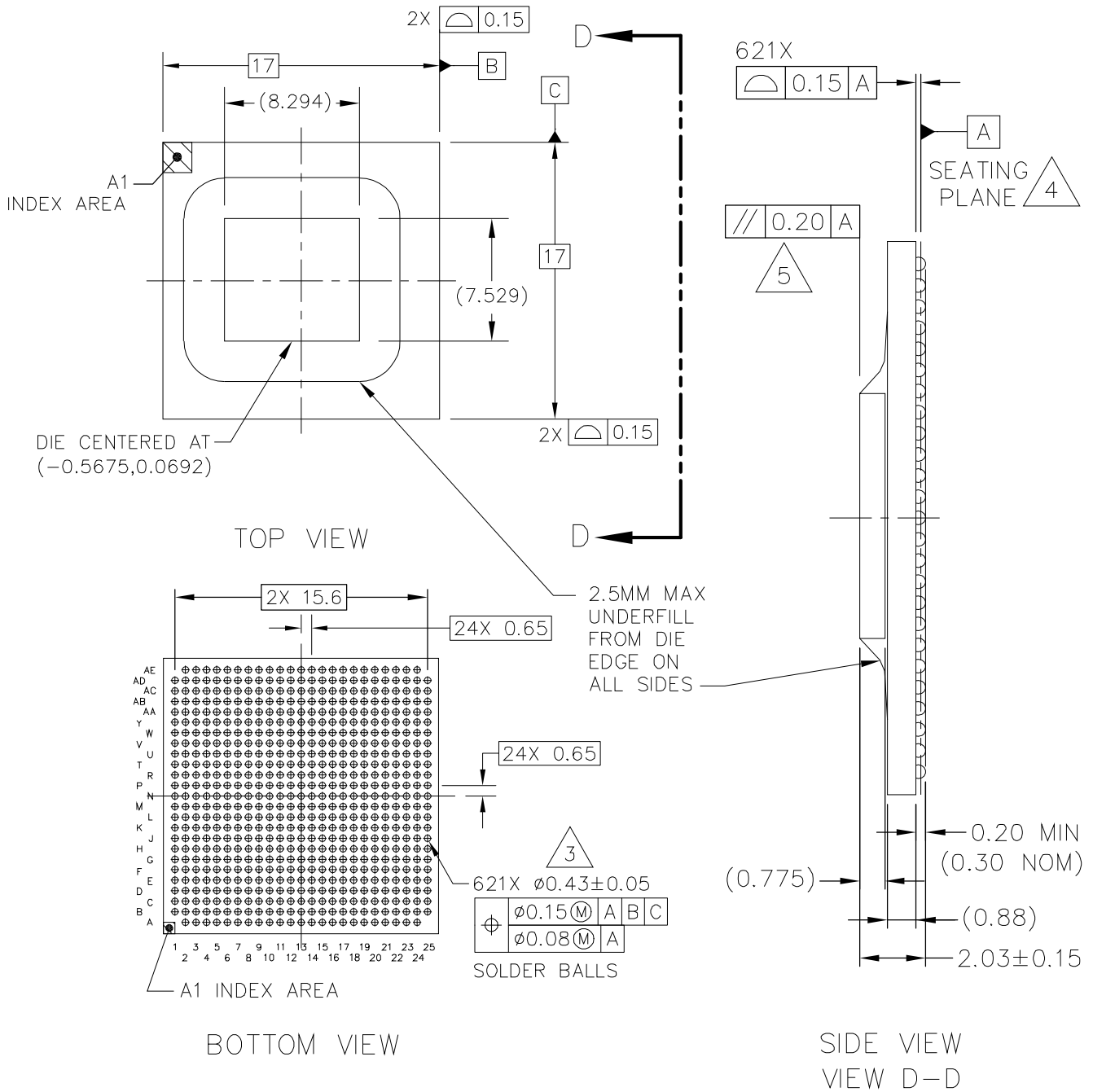

Figure 45. 17 x 17 mm BGA, package top, bottom, and side Views

5.1.2 17 x 17 mm supplies contact assignments and functional contact assignments

Table 84 shows supplies contact assignments for the 17 x 17 mm package.

Table 84. i.MX 8M Dual / 8M QuadLite / 8M Quad 17 x 17 mm supplies contact assignments

Supply Rail Name	Ball(s) Postion(s)	Remark
EFUSE_VQPS	R17	Supply for eFuse Programming
HDMI_AVDDCLK	V3	Supply for HDMI PHY
HDMI_AVDDCORE	U3, U4	Supply for HDMI PHY
HDMI_AVDDIO	P2	Supply for HDMI PHY
MIPI_VDD	E15, F15	Supply for MIPI PHY
MIPI_VDDA	E17, E18, F17, F18	Supply for MIPI PHY
MIPI_VDDHA	C18, D17, D18	Supply for MIPI PHY
MIPI_VDDPLL	F19	Supply for MIPI PHY
NVCC_DRAM	Y12, Y14, AA10, AA15, AB3, AB8, AB17, AB23, AC3, AC6, AC8, AC14, AC17, AC20, AC23, AD5, AD18, AD21	Supply for DRAM Interface
NVCC_ECSPi	F5	Supply for ESCPI Interface
NVCC_ENET	T18	Supply for ENET Interface
NVCC_GPIO1	R5, R6	Supply for GPIO1 Interface
NVCC_I2C	H7	Supply for I2C Interface
NVCC_JTAG	W4	Supply for JTAG Interface
NVCC_NAND	L18, M18	Supply for NAND Interface
NVCC_SAI1	K3, L3	Supply for SAI Interface
NVCC_SAI2	J7	Supply for SAI Interface
NVCC_SAI3	E3	Supply for SAI Interface
NVCC_SAI5	M3	Supply for SAI Interface
NVCC_SD1	L23, M23	Supply for SD Interface
NVCC_SD2	N23	Supply for SD Interface
NVCC_SNVs	W18	Supply for SNVS Interface
NVCC_UART	D8	Supply for UART Interface
PCIE_VP	F22, G22	Supply for PCIe PHY
PCIE_VPH	H23, J23	Supply for PCIe PHY
PCIE_VPTX	F23, G23	Supply for PCIe PHY
USB1_DVDD	E12	Supply for USB PHY
USB1_VDD33	G12	Supply for USB PHY

Table 84. i.MX 8M Dual / 8M QuadLite / 8M Quad 17 x 17 mm supplies contact assignments (continued)

USB1_VP	D12	Supply for USB PHY
USB1_VPH	F12	Supply for USB PHY
USB1_VPTX	C12	Supply for USB PHY
USB2_DVDD	E11	Supply for USB PHY
USB2_VDD33	G11	Supply for USB PHY
USB2_VP	D11	Supply for USB PHY
USB2_VPH	F11	Supply for USB PHY
USB2_VPTX	C11	Supply for USB PHY
VDD_ARM	G14, G15, G16, H14, H15, H16, J15, J16, K15, K16, L15, L16, M15, M16	Supply for Arm Core
VDD_DRAM	U10, U11, U12, U13, U14, V9, V10, V11, V12, V13, V14, V15, Y6, Y8, Y10, Y16, Y18, Y20	Supply for DRAM Module
VDD_GPU	J9, J10, K9, K10, L9, L10, M9, M10	Supply for GPU
VDD_SNVS	R18	Supply for SNVS Logic
VDD_SOC	K12, L12, L13, M12, M13, N13, P12, P13, P15, P16, R8, R9, R10, R11, R12, R13, R14, R15, R16, T8, T17	Supply for SOC Logic
VDD_VPU	N8, N9, N10, P9, P10	Supply for VPU
VDDA_0P9	V18	Supply for SOC Logic
VDDA_1P8_FPLL	U17	Supply for Frac PLL
VDDA_1P8_FPLL_ARM	K14	Supply for Arm PLL
VDDA_1P8_LVDS	U23	Supply for LVDS Interface
VDDA_1P8_SPLL	W17	Supply for SSCG PLL
VDDA_1P8_SPLL_DRAM	T15	Supply for DRAM PLL
VDDA_1P8_SPLL_VIDEO2	N11	Supply for VIDEO PLL2
VDDA_1P8_TSENSOR	T16	Supply for temperature sensor
VDDA_1P8_XTAL_25M	W24	Supply for XTAL
VDDA_1P8_XTAL_27M	W23	Supply for XTAL
VDDA_DRAM	AA11	Supply for DRAM Module

Package information and contact assignments

Table 84. i.MX 8M Dual / 8M QuadLite / 8M Quad 17 x 17 mm supplies contact assignments (continued)

VSS	A2, A24, B1, B25, C8, C10, C13, C15, C24, D10, D13, D15, D23, E4, E10, E13, E14, E16, E19, E20, E21, E22, E23, F10, F13, F14, F16, F20, G9, G10, G13, G17, G18, G24, H8, H9, H10, H11, H12, H13, H17, H18, J3, J8, J11, J12, J13, J14, J17, J18, J19, K8, K11, K17, K18, K23, L8, L11, L14, L17, M8, M11, M14, M17, N3, N14, N15, N16, N17, N18, P6, P8, P11, P14, P17, P18, P23, R7, T3, T4, T9, T10, T11, T12, T13, U8, U9, U15, U18, V4, V8, V16, W1, W7, W8, W9, W10, W11, W12, W13, W14, W15, W16, W25, Y2, Y3, Y4, Y5, Y7, Y9, Y11, Y13, Y15, Y17, Y19, Y21, Y22, Y23, Y24, AA5, AA16, AA21, AB2, AB9, AB11, AB18, AB24, AC4, AC19, AC22, AD1, AD7, AD9, AD11, AD13, AD16, AD25, AE2, AE5, AE21, AE24	—
VSSA_FPLL	U16	Return path of VDDA_1P8_FPLL
VSSA_FPLL_ARM	K13	Return path of VDDA_1P8_FPLL_ARM
VSSA_SPLL	V17	Return path of VDDA_1P8_SPLL
VSSA_SPLL_DRAM	T14	Return path of VDDA_1P8_SPLL_DRAM
VSSA_SPLL_VIDEO2	N12	Return path of VDDA_1P8_SPLL_VIDEO2
VSSA_XTAL_25M	V23	Return path of VDDA_1P8_XTAL_25M
VSSA_XTAL_27M	W22	Return path of VDDA_1P8_XTAL_27M

Table 85 shows an alpha-sorted list of functional contact assignments for the 17 x 17 mm package.

Table 85. i.MX 8M Dual / 8M QuadLite / 8M Quad 17 x 17 mm functional contact assignments

Ball name	Ball	Power group	Ball type ¹	Reset condition ²			
				Default mode (Reset mode)	Default function (Signal name)	Input/Output	Value
BOOT_MODE0	W6	NVCC_JTAG	GPIO	ALT0	ccmsrcgpcmix.BOOT_MODE[0]	Input	PD (90 K)
BOOT_MODE1	V6	NVCC_JTAG	GPIO	ALT0	ccmsrcgpcmix.BOOT_MODE[1]	Input	PD (90 K)
CLK1_P	R23	VDDA	LVDS	—	—	—	—
CLK1_N	T23	VDDA	LVDS	—	—	—	—
CLK2_P	T22	VDDA	LVDS	—	—	—	—
CLK2_N	U22	VDDA	LVDS	—	—	—	—
DRAM_AC00	AC16	NVCC_DRAM	DDR	—	—	—	—

Table 85. i.MX 8M Dual / 8M QuadLite / 8M Quad 17 x 17 mm functional contact assignments (continued)

Ball name	Ball	Power group	Ball type ¹	Reset condition ²			
				Default mode (Reset mode)	Default function (Signal name)	Input/Output	Value
DRAM_AC01	AE17	NVCC_DRAM	DDR	—	—	—	—
DRAM_AC02	AE18	NVCC_DRAM	DDR	—	—	—	—
DRAM_AC03	AC18	NVCC_DRAM	DDR	—	—	—	—
DRAM_AC04	AD14	NVCC_DRAM	DDR	—	—	—	—
DRAM_AC05	AE14	NVCC_DRAM	DDR	—	—	—	—
DRAM_AC06	AE13	NVCC_DRAM	DDR	—	—	—	—
DRAM_AC07	AB15	NVCC_DRAM	DDR	—	—	—	—
DRAM_AC08	AD17	NVCC_DRAM	DDR	—	—	—	—
DRAM_AC09	AE16	NVCC_DRAM	DDR	—	—	—	—
DRAM_AC10	AD20	NVCC_DRAM	DDR	—	—	—	—
DRAM_AC11	AE20	NVCC_DRAM	DDR	—	—	—	—
DRAM_AC12	AD19	NVCC_DRAM	DDR	—	—	—	—
DRAM_AC13	AE19	NVCC_DRAM	DDR	—	—	—	—
DRAM_AC14	AB16	NVCC_DRAM	DDR	—	—	—	—
DRAM_AC15	AC15	NVCC_DRAM	DDR	—	—	—	—
DRAM_AC16	AE15	NVCC_DRAM	DDR	—	—	—	—
DRAM_AC17	AD15	NVCC_DRAM	DDR	—	—	—	—
DRAM_AC19	AB14	NVCC_DRAM	DDR	—	—	—	—
DRAM_AC20	AD10	NVCC_DRAM	DDR	—	—	—	—
DRAM_AC21	AE10	NVCC_DRAM	DDR	—	—	—	—
DRAM_AC22	AD8	NVCC_DRAM	DDR	—	—	—	—
DRAM_AC23	AC9	NVCC_DRAM	DDR	—	—	—	—
DRAM_AC24	AD12	NVCC_DRAM	DDR	—	—	—	—
DRAM_AC25	AE12	NVCC_DRAM	DDR	—	—	—	—
DRAM_AC26	AB12	NVCC_DRAM	DDR	—	—	—	—
DRAM_AC27	AA12	NVCC_DRAM	DDR	—	—	—	—
DRAM_AC28	AC7	NVCC_DRAM	DDR	—	—	—	—
DRAM_AC29	AE7	NVCC_DRAM	DDR	—	—	—	—
DRAM_AC30	AE6	NVCC_DRAM	DDR	—	—	—	—
DRAM_AC31	AD6	NVCC_DRAM	DDR	—	—	—	—

Table 85. i.MX 8M Dual / 8M QuadLite / 8M Quad 17 x 17 mm functional contact assignments (continued)

Ball name	Ball	Power group	Ball type ¹	Reset condition ²			
				Default mode (Reset mode)	Default function (Signal name)	Input/Output	Value
DRAM_AC32	AE8	NVCC_DRAM	DDR	—	—	—	—
DRAM_AC33	AE9	NVCC_DRAM	DDR	—	—	—	—
DRAM_AC34	AC10	NVCC_DRAM	DDR	—	—	—	—
DRAM_AC35	AB10	NVCC_DRAM	DDR	—	—	—	—
DRAM_AC36	AC12	NVCC_DRAM	DDR	—	—	—	—
DRAM_AC37	AE11	NVCC_DRAM	DDR	—	—	—	—
DRAM_AC38	AC11	NVCC_DRAM	DDR	—	—	—	—
DRAM_ALERT_N	AC13	NVCC_DRAM	DDR	—	—	—	—
DRAM_DM0	AD23	NVCC_DRAM	DDR	—	—	—	—
DRAM_DM1	AB20	NVCC_DRAM	DDR	—	—	—	—
DRAM_DM2	AD3	NVCC_DRAM	DDR	—	—	—	—
DRAM_DM3	AB6	NVCC_DRAM	DDR	—	—	—	—
DRAM_DQ00	AE23	NVCC_DRAM	DDR	—	—	—	—
DRAM_DQ01	AD24	NVCC_DRAM	DDR	—	—	—	—
DRAM_DQ02	AE22	NVCC_DRAM	DDR	—	—	—	—
DRAM_DQ03	AD22	NVCC_DRAM	DDR	—	—	—	—
DRAM_DQ04	AA24	NVCC_DRAM	DDR	—	—	—	—
DRAM_DQ05	Y25	NVCC_DRAM	DDR	—	—	—	—
DRAM_DQ06	AA25	NVCC_DRAM	DDR	—	—	—	—
DRAM_DQ07	AB25	NVCC_DRAM	DDR	—	—	—	—
DRAM_DQ08	AB22	NVCC_DRAM	DDR	—	—	—	—
DRAM_DQ09	AA22	NVCC_DRAM	DDR	—	—	—	—
DRAM_DQ10	AA23	NVCC_DRAM	DDR	—	—	—	—
DRAM_DQ11	AA20	NVCC_DRAM	DDR	—	—	—	—
DRAM_DQ12	AA18	NVCC_DRAM	DDR	—	—	—	—
DRAM_DQ13	AB19	NVCC_DRAM	DDR	—	—	—	—
DRAM_DQ14	AA19	NVCC_DRAM	DDR	—	—	—	—
DRAM_DQ15	AA17	NVCC_DRAM	DDR	—	—	—	—
DRAM_DQ16	AE3	NVCC_DRAM	DDR	—	—	—	—
DRAM_DQ17	AD2	NVCC_DRAM	DDR	—	—	—	—

Table 85. i.MX 8M Dual / 8M QuadLite / 8M Quad 17 x 17 mm functional contact assignments (continued)

Ball name	Ball	Power group	Ball type ¹	Reset condition ²			
				Default mode (Reset mode)	Default function (Signal name)	Input/Output	Value
DRAM_DQ18	AE4	NVCC_DRAM	DDR	—	—	—	—
DRAM_DQ19	AD4	NVCC_DRAM	DDR	—	—	—	—
DRAM_DQ20	AA2	NVCC_DRAM	DDR	—	—	—	—
DRAM_DQ21	Y1	NVCC_DRAM	DDR	—	—	—	—
DRAM_DQ22	AA1	NVCC_DRAM	DDR	—	—	—	—
DRAM_DQ23	AB1	NVCC_DRAM	DDR	—	—	—	—
DRAM_DQ24	AB4	NVCC_DRAM	DDR	—	—	—	—
DRAM_DQ25	AA4	NVCC_DRAM	DDR	—	—	—	—
DRAM_DQ26	AA3	NVCC_DRAM	DDR	—	—	—	—
DRAM_DQ27	AA6	NVCC_DRAM	DDR	—	—	—	—
DRAM_DQ28	AA8	NVCC_DRAM	DDR	—	—	—	—
DRAM_DQ29	AB7	NVCC_DRAM	DDR	—	—	—	—
DRAM_DQ30	AA7	NVCC_DRAM	DDR	—	—	—	—
DRAM_DQ31	AA9	NVCC_DRAM	DDR	—	—	—	—
DRAM_DQS0_N	AC25	NVCC_DRAM	DDRCLK	—	—	—	—
DRAM_DQS0_P	AC24	NVCC_DRAM	DDRCLK	—	—	—	—
DRAM_DQS1_N	AC21	NVCC_DRAM	DDRCLK	—	—	—	—
DRAM_DQS1_P	AB21	NVCC_DRAM	DDRCLK	—	—	—	—
DRAM_DQS2_N	AC1	NVCC_DRAM	DDRCLK	—	—	—	—
DRAM_DQS2_P	AC2	NVCC_DRAM	DDRCLK	—	—	—	—
DRAM_DQS3_N	AC5	NVCC_DRAM	DDRCLK	—	—	—	—
DRAM_DQS3_P	AB5	NVCC_DRAM	DDRCLK	—	—	—	—
DRAM_RESET_N	AB13	NVCC_DRAM	DDR	—	—	—	—
DRAM_VREF	AA14	NVCC_DRAM	DDR	—	—	—	—
DRAM_ZN	AA13	NVCC_DRAM	DDR	—	—	—	—
ECSPI1_MISO	B4	NVCC_ECSPi	GPIO	ALT5	GPIO5.IO[8]	Input	PD (90 K)
ECSPI1_MOSI	A4	NVCC_ECSPi	GPIO	ALT5	GPIO5.IO[7]	Input	PD (90 K)
ECSPI1_SCLK	D5	NVCC_ECSPi	GPIO	ALT5	GPIO5.IO[6]	Input	PD (90 K)
ECSPI1_SS0	D4	NVCC_ECSPi	GPIO	ALT5	GPIO5.IO[9]	Input	PD (90 K)
ECSPI2_MISO	B5	NVCC_ECSPi	GPIO	ALT5	GPIO5.IO[12]	Input	PD (90 K)

Table 85. i.MX 8M Dual / 8M QuadLite / 8M Quad 17 x 17 mm functional contact assignments (continued)

Ball name	Ball	Power group	Ball type ¹	Reset condition ²			
				Default mode (Reset mode)	Default function (Signal name)	Input/Output	Value
ECSPI2_MOSI	E5	NVCC_ECSPi	GPIO	ALT5	GPIO5.IO[11]	Input	PD (90 K)
ECSPI2_SCLK	C5	NVCC_ECSPi	GPIO	ALT5	GPIO5.IO[10]	Input	PD (90 K)
ECSPI2_SS0	A5	NVCC_ECSPi	GPIO	ALT5	GPIO5.IO[13]	Input	PD (90 K)
ENET_MDC	N20	NVCC_ENET	GPIO	ALT5	GPIO1.IO[16]	Input	PD (90 K)
ENET_MDIO	N19	NVCC_ENET	GPIO	ALT5	GPIO1.IO[17]	Input	PD (90 K)
ENET_RD0	U19	NVCC_ENET	GPIO	ALT5	GPIO1.IO[26]	Input	PD (90 K)
ENET_RD1	U21	NVCC_ENET	GPIO	ALT5	GPIO1.IO[27]	Input	PD (90 K)
ENET_RD2	U20	NVCC_ENET	GPIO	ALT5	GPIO1.IO[28]	Input	PD (90 K)
ENET_RD3	V19	NVCC_ENET	GPIO	ALT5	GPIO1.IO[29]	Input	PD (90 K)
ENET_RXC	T20	NVCC_ENET	GPIO	ALT5	GPIO1.IO[25]	Input	PD (90 K)
ENET_RX_CTL	T21	NVCC_ENET	GPIO	ALT5	GPIO1.IO[24]	Input	PD (90 K)
ENET_TD0	R20	NVCC_ENET	GPIO	ALT5	GPIO1.IO[21]	Input	PD (90 K)
ENET_TD1	R21	NVCC_ENET	GPIO	ALT5	GPIO1.IO[20]	Input	PD (90 K)
ENET_TD2	R19	NVCC_ENET	GPIO	ALT5	GPIO1.IO[19]	Input	PD (90 K)
ENET_TD3	P20	NVCC_ENET	GPIO	ALT5	GPIO1.IO[18]	Input	PD (90 K)
ENET_TXC	T19	NVCC_ENET	GPIO	ALT5	GPIO1.IO[23]	Input	PD (90 K)
ENET_TX_CTL	P19	NVCC_ENET	GPIO	ALT5	GPIO1.IO[22]	Input	PD (90 K)
GPIO1_IO00	T6	NVCC_GPIO1	GPIO	ALT0	GPIO1.IO[0]	Input	PD (90 K)
GPIO1_IO01 ³	T7	NVCC_GPIO1	GPIO	ALT0	GPIO1.IO[1]	Input	PD (90 K)
GPIO1_IO02	R4	NVCC_GPIO1	GPIO	ALT0	GPIO1.IO[2]	Input	PD (27 K)
GPIO1_IO03	P4	NVCC_GPIO1	GPIO	ALT0	GPIO1.IO[3]	Input	PD (90 K)
GPIO1_IO04	P5	NVCC_GPIO1	GPIO	ALT0	GPIO1.IO[4]	Input	PD (90 K)
GPIO1_IO05 ⁴	P7	NVCC_GPIO1	GPIO	ALT0	GPIO1.IO[5]	Input	PU (27 K)
GPIO1_IO06	N5	NVCC_GPIO1	GPIO	ALT0	GPIO1.IO[6]	Input	PD (90 K)
GPIO1_IO07	N6	NVCC_GPIO1	GPIO	ALT0	GPIO1.IO[7]	Input	PD (90 K)
GPIO1_IO08	N7	NVCC_GPIO1	GPIO	ALT0	GPIO1.IO[8]	Input	PD (90 K)
GPIO1_IO09	M6	NVCC_GPIO1	GPIO	ALT0	GPIO1.IO[9]	Input	PD (90 K)
GPIO1_IO10	M7	NVCC_GPIO1	GPIO	ALT0	GPIO1.IO[10]	Input	PD (90 K)
GPIO1_IO11	L6	NVCC_GPIO1	GPIO	ALT0	GPIO1.IO[11]	Input	PD (90 K)
GPIO1_IO12	L7	NVCC_GPIO1	GPIO	ALT0	GPIO1.IO[12]	Input	PD (90 K)

Table 85. i.MX 8M Dual / 8M QuadLite / 8M Quad 17 x 17 mm functional contact assignments (continued)

Ball name	Ball	Power group	Ball type ¹	Reset condition ²			
				Default mode (Reset mode)	Default function (Signal name)	Input/Output	Value
GPIO1_IO13	K6	NVCC_GPIO1	GPIO	ALT0	GPIO1.IO[13]	Input	PD (90 K)
GPIO1_IO14	K7	NVCC_GPIO1	GPIO	ALT0	GPIO1.IO[14]	Input	PD (90 K)
GPIO1_IO15	J6	NVCC_GPIO1	GPIO	ALT0	GPIO1.IO[15]	Input	PD (90 K)
HDMI_AUX_N	V2	HDMI_AVDDIO	PHY	—	—	—	—
HDMI_AUX_P	V1	HDMI_AVDDIO	PHY	—	—	—	—
HDMI_CEC	W3	HDMI_AVDDIO	PHY	—	—	—	—
HDMI_DDC_SCL	R3	HDMI_AVDDIO	PHY	—	—	—	—
HDMI_DDC_SDA	P3	HDMI_AVDDIO	PHY	—	—	—	—
HDMI_HPD	W2	HDMI_AVDDIO	PHY	—	—	—	—
HDMI_REFCLK_N	R1	HDMI_AVDDIO	PHY	—	—	—	—
HDMI_REFCLK_P	R2	HDMI_AVDDIO	PHY	—	—	—	—
HDMI_REXT	P1	HDMI_AVDDIO	PHY	—	—	—	—
HDMI_TX_M_LN_0	T2	HDMI_AVDDIO	PHY	—	—	—	—
HDMI_TX_M_LN_1	U1	HDMI_AVDDIO	PHY	—	—	—	—
HDMI_TX_M_LN_2	N1	HDMI_AVDDIO	PHY	—	—	—	—
HDMI_TX_M_LN_3	M2	HDMI_AVDDIO	PHY	—	—	—	—
HDMI_TX_P_LN_0	T1	HDMI_AVDDIO	PHY	—	—	—	—
HDMI_TX_P_LN_1	U2	HDMI_AVDDIO	PHY	—	—	—	—
HDMI_TX_P_LN_2	N2	HDMI_AVDDIO	PHY	—	—	—	—
HDMI_TX_P_LN_3	M1	HDMI_AVDDIO	PHY	—	—	—	—
I2C1_SCL	E7	NVCC_I2C	GPIO	ALT5	GPIO5.IO[14]	Input	PD (90 K)
I2C1_SDA	E8	NVCC_I2C	GPIO	ALT5	GPIO5.IO[15]	Input	PD (90 K)
I2C2_SCL	G7	NVCC_I2C	GPIO	ALT5	GPIO5.IO[16]	Input	PD (90 K)
I2C2_SDA	F7	NVCC_I2C	GPIO	ALT5	GPIO5.IO[17]	Input	PD (90 K)
I2C3_SCL	G8	NVCC_I2C	GPIO	ALT5	GPIO5.IO[18]	Input	PD (90 K)
I2C3_SDA	E9	NVCC_I2C	GPIO	ALT5	GPIO5.IO[19]	Input	PD (90 K)
I2C4_SCL	F8	NVCC_I2C	GPIO	ALT5	GPIO5.IO[20]	Input	PD (90 K)
I2C4_SDA	F9	NVCC_I2C	GPIO	ALT5	GPIO5.IO[21]	Input	PD (90 K)
JTAG_MOD	U7	NVCC_JTAG	GPIO	ALT0	cjtag_wrapper.MOD	Input	PD (90 K)
JTAG_TCK	T5	NVCC_JTAG	GPIO	ALT0	cjtag_wrapper.TCK	Input	PU 27 K)

Table 85. i.MX 8M Dual / 8M QuadLite / 8M Quad 17 x 17 mm functional contact assignments (continued)

Ball name	Ball	Power group	Ball type ¹	Reset condition ²			
				Default mode (Reset mode)	Default function (Signal name)	Input/Output	Value
JTAG_TDI	W5	NVCC_JTAG	GPIO	ALT0	cjtag_wrapper.TDI	Input	PU (27 K)
JTAG_TDO	U5	NVCC_JTAG	GPIO	ALT0	cjtag_wrapper.TDO	Input	PU (27 K)
JTAG_TMS	V5	NVCC_JTAG	GPIO	ALT0	cjtag_wrapper.TMS	Input	PU (27 K)
JTAG_TRST_B	U6	NVCC_JTAG	GPIO	ALT0	cjtag_wrapper.TRST_B	Input	PU (27 K)
MIPI_CSI1_CLK_N	A22	MIPI_VDDHA	PHY	—	—	—	—
MIPI_CSI1_CLK_P	B22	MIPI_VDDHA	PHY	—	—	—	—
MIPI_CSI1_D0_N	A23	MIPI_VDDHA	PHY	—	—	—	—
MIPI_CSI1_D0_P	B23	MIPI_VDDHA	PHY	—	—	—	—
MIPI_CSI1_D1_N	C22	MIPI_VDDHA	PHY	—	—	—	—
MIPI_CSI1_D1_P	D22	MIPI_VDDHA	PHY	—	—	—	—
MIPI_CSI1_D2_N	B24	MIPI_VDDHA	PHY	—	—	—	—
MIPI_CSI1_D2_P	C23	MIPI_VDDHA	PHY	—	—	—	—
MIPI_CSI1_D3_N	C21	MIPI_VDDHA	PHY	—	—	—	—
MIPI_CSI1_D3_P	D21	MIPI_VDDHA	PHY	—	—	—	—
MIPI_CSI2_CLK_N	A19	MIPI_VDDHA	PHY	—	—	—	—
MIPI_CSI2_CLK_P	B19	MIPI_VDDHA	PHY	—	—	—	—
MIPI_CSI2_D0_N	C20	MIPI_VDDHA	PHY	—	—	—	—
MIPI_CSI2_D0_P	D20	MIPI_VDDHA	PHY	—	—	—	—
MIPI_CSI2_D1_N	A20	MIPI_VDDHA	PHY	—	—	—	—
MIPI_CSI2_D1_P	B20	MIPI_VDDHA	PHY	—	—	—	—
MIPI_CSI2_D2_N	A21	MIPI_VDDHA	PHY	—	—	—	—
MIPI_CSI2_D2_P	B21	MIPI_VDDHA	PHY	—	—	—	—
MIPI_CSI2_D3_N	C19	MIPI_VDDHA	PHY	—	—	—	—
MIPI_CSI2_D3_P	D19	MIPI_VDDHA	PHY	—	—	—	—
MIPI_DSI_CLK_N	C16	MIPI_VDDHA	PHY	—	—	—	—
MIPI_DSI_CLK_P	D16	MIPI_VDDHA	PHY	—	—	—	—
MIPI_DSI_D0_N	A17	MIPI_VDDHA	PHY	—	—	—	—
MIPI_DSI_D0_P	B17	MIPI_VDDHA	PHY	—	—	—	—
MIPI_DSI_D1_N	A16	MIPI_VDDHA	PHY	—	—	—	—
MIPI_DSI_D1_P	B16	MIPI_VDDHA	PHY	—	—	—	—

Table 85. i.MX 8M Dual / 8M QuadLite / 8M Quad 17 x 17 mm functional contact assignments (continued)

Ball name	Ball	Power group	Ball type ¹	Reset condition ²			
				Default mode (Reset mode)	Default function (Signal name)	Input/Output	Value
MIPI_DSI_D2_N	A18	MIPI_VDDHA	PHY	—	—	—	—
MIPI_DSI_D2_P	B18	MIPI_VDDHA	PHY	—	—	—	—
MIPI_DSI_D3_N	A15	MIPI_VDDHA	PHY	—	—	—	—
MIPI_DSI_D3_P	B15	MIPI_VDDHA	PHY	—	—	—	—
MIPI_DSI_REXT	C17	MIPI_VDDHA	PHY	—	—	—	—
NAND_ALE	G19	NVCC_NAND	GPIO	ALT5	GPIO3.IO[0]	Input	PD (90 K)
NAND_CE0_B	H19	NVCC_NAND	GPIO	ALT5	GPIO3.IO[1]	Input	PD (90 K)
NAND_CE1_B	G21	NVCC_NAND	GPIO	ALT5	GPIO3.IO[2]	Input	PD (90 K)
NAND_CE2_B	F21	NVCC_NAND	GPIO	ALT5	GPIO3.IO[3]	Input	PD (90 K)
NAND_CE3_B	H20	NVCC_NAND	GPIO	ALT5	GPIO3.IO[4]	Input	PD (90 K)
NAND_CLE	H21	NVCC_NAND	GPIO	ALT5	GPIO3.IO[5]	Input	PD (90 K)
NAND_DATA00	G20	NVCC_NAND	GPIO	ALT5	GPIO3.IO[6]	Input	PD (90 K)
NAND_DATA01	J20	NVCC_NAND	GPIO	ALT5	GPIO3.IO[7]	Input	PD (90 K)
NAND_DATA02	H22	NVCC_NAND	GPIO	ALT5	GPIO3.IO[8]	Input	PD (90 K)
NAND_DATA03	J21	NVCC_NAND	GPIO	ALT5	GPIO3.IO[9]	Input	PD (90 K)
NAND_DATA04	L20	NVCC_NAND	GPIO	ALT5	GPIO3.IO[10]	Input	PD (90 K)
NAND_DATA05	J22	NVCC_NAND	GPIO	ALT5	GPIO3.IO[11]	Input	PD (90 K)
NAND_DATA06	L19	NVCC_NAND	GPIO	ALT5	GPIO3.IO[12]	Input	PD (90 K)
NAND_DATA07	M19	NVCC_NAND	GPIO	ALT5	GPIO3.IO[13]	Input	PD (90 K)
NAND_DQS	M20	NVCC_NAND	GPIO	ALT5	GPIO3.IO[14]	Input	PD (90 K)
NAND_RE_B	K19	NVCC_NAND	GPIO	ALT5	GPIO3.IO[15]	Input	PD (90 K)
NAND_READY_B	K20	NVCC_NAND	GPIO	ALT5	GPIO3.IO[16]	Input	PD (90 K)
NAND_WE_B	K22	NVCC_NAND	GPIO	ALT5	GPIO3.IO[17]	Input	PD (90 K)
NAND_WP_B	K21	NVCC_NAND	GPIO	ALT5	GPIO3.IO[18]	Input	PD (90 K)
ONOFF	W21	NVCC_SNVS	GPIO	ALT0	snvsmix.ONOFF	Input	PU (27 K)
PCIE1_REF_PAD_C LK_N	K24	PCIE_VPH	PHY	—	—	—	—
PCIE1_REF_PAD_C LK_P	K25	PCIE_VPH	PHY	—	—	—	—
PCIE1_RESREF	G25	PCIE_VPH	PHY	—	—	—	—

Table 85. i.MX 8M Dual / 8M QuadLite / 8M Quad 17 x 17 mm functional contact assignments (continued)

Ball name	Ball	Power group	Ball type ¹	Reset condition ²			
				Default mode (Reset mode)	Default function (Signal name)	Input/Output	Value
PCIE1_RXN_N	H24	PCIE_VPH	PHY	—	—	—	—
PCIE1_RXN_P	H25	PCIE_VPH	PHY	—	—	—	—
PCIE1_TXN_N	J24	PCIE_VPH	PHY	—	—	—	—
PCIE1_TXN_P	J25	PCIE_VPH	PHY	—	—	—	—
PCIE2_REF_PAD_C LK_N	F24	PCIE_VPH	PHY	—	—	—	—
PCIE2_REF_PAD_C LK_P	F25	PCIE_VPH	PHY	—	—	—	—
PCIE2_RESREF	C25	PCIE_VPH	PHY	—	—	—	—
PCIE2_RXN_N	D24	PCIE_VPH	PHY	—	—	—	—
PCIE2_RXN_P	D25	PCIE_VPH	PHY	—	—	—	—
PCIE2_TXN_N	E24	PCIE_VPH	PHY	—	—	—	—
PCIE2_TXN_P	E25	PCIE_VPH	PHY	—	—	—	—
PMIC_ON_REQ	V20	NVCC_SNVS	GPIO	ALT0	snvsmix.PMIC_ON_RE Q	Output	Open-Drain PU (27 K)
PMIC_STBY_REQ	V21	NVCC_SNVS	GPIO	ALT0	ccmsrcgpcmix.PMIC_S TBY_REQ	Output	Low
POR_B	W20	NVCC_SNVS	GPIO	ALT0	snvsmix.POR_B	Input	PU (27 K)
RTC	V22	NVCC_SNVS	GPIO	ALT0	snvsmix.RTC	Input	PD (90 K)
RTC_RESET_B	W19	NVCC_SNVS	GPIO	ALT0	snvsmix.RTC_POR_B	Input	PU (27 K)
SAI1_MCLK	A3	NVCC_SAI1	GPIO	ALT5	GPIO4.IO[20]	Input	PD (90 K)
SAI1_RXC	K1	NVCC_SAI1	GPIO	ALT5	GPIO4.IO[1]	Input	PD (90 K)
SAI1_RXD0 ⁵	K2	NVCC_SAI1	GPIO	ALT5	GPIO4.IO[2]	Input	PD (90 K)
SAI1_RXD1 ⁵	L2	NVCC_SAI1	GPIO	ALT5	GPIO4.IO[3]	Input	PD (90 K)
SAI1_RXD2 ⁵	H2	NVCC_SAI1	GPIO	ALT5	GPIO4.IO[4]	Input	PD (90 K)
SAI1_RXD3 ⁵	J2	NVCC_SAI1	GPIO	ALT5	GPIO4.IO[5]	Input	PD (90 K)
SAI1_RXD4 ⁵	J1	NVCC_SAI1	GPIO	ALT5	GPIO4.IO[6]	Input	PD (90 K)
SAI1_RXD5 ⁵	F1	NVCC_SAI1	GPIO	ALT5	GPIO4.IO[7]	Input	PD (90 K)
SAI1_RXD6 ⁵	G2	NVCC_SAI1	GPIO	ALT5	GPIO4.IO[8]	Input	PD (90 K)
SAI1_RXD7 ⁵	G1	NVCC_SAI1	GPIO	ALT5	GPIO4.IO[9]	Input	PD (90 K)
SAI1_RXFS	L1	NVCC_SAI1	GPIO	ALT5	GPIO4.IO[0]	Input	PD (90 K)

Table 85. i.MX 8M Dual / 8M QuadLite / 8M Quad 17 x 17 mm functional contact assignments (continued)

Ball name	Ball	Power group	Ball type ¹	Reset condition ²			
				Default mode (Reset mode)	Default function (Signal name)	Input/Output	Value
SAI1_TXC	E1	NVCC_SAI1	GPIO	ALT5	GPIO4.IO[11]	Input	PD (90 K)
SAI1_TXD0 ⁵	F2	NVCC_SAI1	GPIO	ALT5	GPIO4.IO[12]	Input	PD (90 K)
SAI1_TXD1 ⁵	E2	NVCC_SAI1	GPIO	ALT5	GPIO4.IO[13]	Input	PD (90 K)
SAI1_TXD2 ⁵	B2	NVCC_SAI1	GPIO	ALT5	GPIO4.IO[14]	Input	PD (90 K)
SAI1_TXD3 ⁵	D1	NVCC_SAI1	GPIO	ALT5	GPIO4.IO[15]	Input	PD (90 K)
SAI1_TXD4 ⁵	D2	NVCC_SAI1	GPIO	ALT5	GPIO4.IO[16]	Input	PD (90 K)
SAI1_TXD5 ⁵	C2	NVCC_SAI1	GPIO	ALT5	GPIO4.IO[17]	Input	PD (90 K)
SAI1_TXD6 ⁵	B3	NVCC_SAI1	GPIO	ALT5	GPIO4.IO[18]	Input	PD (90 K)
SAI1_TXD7 ⁵	C1	NVCC_SAI1	GPIO	ALT5	GPIO4.IO[19]	Input	PD (90 K)
SAI1_TXFS	H1	NVCC_SAI1	GPIO	ALT5	GPIO4.IO[10]	Input	PD (90 K)
SAI2_MCLK	H5	NVCC_SAI2	GPIO	ALT5	GPIO4.IO[27]	Input	PD (90 K)
SAI2_RXC	H3	NVCC_SAI2	GPIO	ALT5	GPIO4.IO[22]	Input	PD (90 K)
SAI2_RXD0	H6	NVCC_SAI2	GPIO	ALT5	GPIO4.IO[23]	Input	PD (90 K)
SAI2_RXFS	J4	NVCC_SAI2	GPIO	ALT5	GPIO4.IO[21]	Input	PD (90 K)
SAI2_TXC	J5	NVCC_SAI2	GPIO	ALT5	GPIO4.IO[25]	Input	PD (90 K)
SAI2_TXD0	G5	NVCC_SAI2	GPIO	ALT5	GPIO4.IO[26]	Input	PD (90 K)
SAI2_TXFS	H4	NVCC_SAI2	GPIO	ALT5	GPIO4.IO[24]	Input	PD (90 K)
SAI3_MCLK	D3	NVCC_SAI3	GPIO	ALT5	GPIO5.IO[2]	Input	PD (90 K)
SAI3_RXC	F4	NVCC_SAI3	GPIO	ALT5	GPIO4.IO[29]	Input	PD (90 K)
SAI3_RXD	F3	NVCC_SAI3	GPIO	ALT5	GPIO4.IO[30]	Input	PD (90 K)
SAI3_RXFS	G4	NVCC_SAI3	GPIO	ALT5	GPIO4.IO[28]	Input	PD (90 K)
SAI3_TXC	C4	NVCC_SAI3	GPIO	ALT5	GPIO5.IO[0]	Input	PD (90 K)
SAI3_TXD	C3	NVCC_SAI3	GPIO	ALT5	GPIO5.IO[1]	Input	PD (90 K)
SAI3_TXFS	G3	NVCC_SAI3	GPIO	ALT5	GPIO4.IO[31]	Input	PD (90 K)
SAI5_MCLK	K4	NVCC_SAI5	GPIO	ALT5	GPIO3.IO[25]	Input	PD (90 K)
SAI5_RXC	L5	NVCC_SAI5	GPIO	ALT5	GPIO3.IO[20]	Input	PD (90 K)
SAI5_RXD0	M5	NVCC_SAI5	GPIO	ALT5	GPIO3.IO[21]	Input	PD (90 K)
SAI5_RXD1	L4	NVCC_SAI5	GPIO	ALT5	GPIO3.IO[22]	Input	PD (90 K)
SAI5_RXD2	M4	NVCC_SAI5	GPIO	ALT5	GPIO3.IO[23]	Input	PD (90 K)
SAI5_RXD3	K5	NVCC_SAI5	GPIO	ALT5	GPIO3.IO[24]	Input	PD (90 K)

Table 85. i.MX 8M Dual / 8M QuadLite / 8M Quad 17 x 17 mm functional contact assignments (continued)

Ball name	Ball	Power group	Ball type ¹	Reset condition ²			
				Default mode (Reset mode)	Default function (Signal name)	Input/Output	Value
SAI5_RXFS	N4	NVCC_SAI5	GPIO	ALT5	GPIO3.IO[19]	Input	PD (90 K)
SD1_CLK	L25	NVCC_SD1	GPIO	ALT5	GPIO2.IO[0]	Input	PD (90 K)
SD1_CMD	L24	NVCC_SD1	GPIO	ALT5	GPIO2.IO[1]	Input	PD (90 K)
SD1_DATA0	M25	NVCC_SD1	GPIO	ALT5	GPIO2.IO[2]	Input	PD (90 K)
SD1_DATA1	M24	NVCC_SD1	GPIO	ALT5	GPIO2.IO[3]	Input	PD (90 K)
SD1_DATA2	N25	NVCC_SD1	GPIO	ALT5	GPIO2.IO[4]	Input	PD (90 K)
SD1_DATA3	P25	NVCC_SD1	GPIO	ALT5	GPIO2.IO[5]	Input	PD (90 K)
SD1_DATA4	N24	NVCC_SD1	GPIO	ALT5	GPIO2.IO[6]	Input	PD (90 K)
SD1_DATA5	P24	NVCC_SD1	GPIO	ALT5	GPIO2.IO[7]	Input	PD (90 K)
SD1_DATA6	R25	NVCC_SD1	GPIO	ALT5	GPIO2.IO[8]	Input	PD (90 K)
SD1_DATA7	T25	NVCC_SD1	GPIO	ALT5	GPIO2.IO[9]	Input	PD (90 K)
SD1_RESET_B	R24	NVCC_SD1	GPIO	ALT5	GPIO2.IO[10]	Input	PD (90 K)
SD1_STROBE	T24	NVCC_SD1	GPIO	ALT5	GPIO2.IO[11]	Input	PD (90 K)
SD2_CD_B	L21	NVCC_SD2	GPIO	ALT5	GPIO2.IO[12]	Input	PD (90 K)
SD2_CLK	L22	NVCC_SD2	GPIO	ALT5	GPIO2.IO[13]	Input	PD (90 K)
SD2_CMD	M22	NVCC_SD2	GPIO	ALT5	GPIO2.IO[14]	Input	PD (90 K)
SD2_DATA0	N22	NVCC_SD2	GPIO	ALT5	GPIO2.IO[15]	Input	PD (90 K)
SD2_DATA1	N21	NVCC_SD2	GPIO	ALT5	GPIO2.IO[16]	Input	PD (90 K)
SD2_DATA2	P22	NVCC_SD2	GPIO	ALT5	GPIO2.IO[17]	Input	PD (90 K)
SD2_DATA3	P21	NVCC_SD2	GPIO	ALT5	GPIO2.IO[18]	Input	PD (90 K)
SD2_RESET_B	R22	NVCC_SD2	GPIO	ALT5	GPIO2.IO[19]	Input	PD (90 K)
SD2_WP	M21	NVCC_SD2	GPIO	ALT5	GPIO2.IO[20]	Input	PD (90 K)
SPDIF_EXT_CLK	E6	NVCC_SAI3	GPIO	ALT5	GPIO5.IO[5]	Input	PD (90 K)
SPDIF_RX	G6	NVCC_SAI3	GPIO	ALT5	GPIO5.IO[4]	Input	PD (90 K)
SPDIF_TX	F6	NVCC_SAI3	GPIO	ALT5	GPIO5.IO[3]	Input	PD (90 K)
TEST_MODE	V7	NVCC_JTAG	GPIO	ALT0	tcu.TEST_MODE	Input	PD (90 K)
UART1_RXD	C7	NVCC_UART	GPIO	ALT5	GPIO5.IO[22]	Input	PD (90 K)
UART1_TXD	A7	NVCC_UART	GPIO	ALT5	GPIO5.IO[23]	Input	PD (90 K)
UART2_RXD	B6	NVCC_UART	GPIO	ALT5	GPIO5.IO[24]	Input	PD (90 K)
UART2_TXD	D6	NVCC_UART	GPIO	ALT5	GPIO5.IO[25]	Input	PD (90 K)

Table 85. i.MX 8M Dual / 8M QuadLite / 8M Quad 17 x 17 mm functional contact assignments (continued)

Ball name	Ball	Power group	Ball type ¹	Reset condition ²			
				Default mode (Reset mode)	Default function (Signal name)	Input/Output	Value
UART3_RXD	A6	NVCC_UART	GPIO	ALT5	GPIO5.IO[26]	Input	PD (90 K)
UART3_TXD	B7	NVCC_UART	GPIO	ALT5	GPIO5.IO[27]	Input	PD (90 K)
UART4_RXD	C6	NVCC_UART	GPIO	ALT5	GPIO5.IO[28]	Input	PD (90 K)
UART4_TXD	D7	NVCC_UART	GPIO	ALT5	GPIO5.IO[29]	Input	PD (90 K)
USB1_DN	B14	USB1_VDD33	PHY	—	—	—	—
USB1_DP	A14	USB1_VDD33	PHY	—	—	—	—
USB1_ID	C14	USB1_VDD33	PHY	—	—	—	—
USB1_RESREF	A11	USB1_VPH	PHY	—	—	—	—
USB1_RX_N	B12	USB1_VPH	PHY	—	—	—	—
USB1_RX_P	A12	USB1_VPH	PHY	—	—	—	—
USB1_TX_N	B13	USB1_VPH	PHY	—	—	—	—
USB1_TX_P	A13	USB1_VPH	PHY	—	—	—	—
USB1_VBUS	D14	USB1_VDD33	PHY	—	—	—	—
USB2_DN	B10	USB2_VDD33	PHY	—	—	—	—
USB2_DP	A10	USB2_VDD33	PHY	—	—	—	—
USB2_ID	C9	USB2_VDD33	PHY	—	—	—	—
USB2_RESREF	B11	USB2_VPH	PHY	—	—	—	—
USB2_RX_N	B8	USB2_VPH	PHY	—	—	—	—
USB2_RX_P	A8	USB2_VPH	PHY	—	—	—	—
USB2_TX_N	B9	USB2_VPH	PHY	—	—	—	—
USB2_TX_P	A9	USB2_VPH	PHY	—	—	—	—
USB2_VBUS	D9	USB2_VDD33	PHY	—	—	—	—
XTALI_25M	U25	VDDA	ANALOG	—	—	—	—
XTALI_27M	V25	VDDA	ANALOG	—	—	—	—
XTALO_25M	U24	VDDA	ANALOG	—	—	—	—
XTALO_27M	V24	VDDA	ANALOG	—	—	—	—

¹ The state immediately after RESET and before ROM firmware or software has executed.

² The state during, after RESET and before ROM firmware or software has executed.

³ Jtag Active output during reset

⁴ INT_BOOT output (High) during reset

⁵ Boot Configure Input

5.1.3 i.MX 8M Dual / 8M QuadLite / 8M Quad 17 x 17 mm 0.65 mm pitch ball map

Table 86 shows the i.MX 8M Dual / 8M QuadLite / 8M Quad 17 x 17 mm, 0.65 mm pitch ball map.

Table 86. 17 x 17 mm, 0.65 mm pitch ball map

	1	2	3	4	5	6	7	8	9	10	11	12	13	14	15	16	17	18	19	20	21	22	23	24	25
F	E	D	C	B	A																				
SAI1_RXD5	SAI1_TXC	SAI1_TXD3	SAI1_TXD7	VSS																					
SAI1_TXD0	SAI1_TXD1	SAI1_TXD4	SAI1_TXD5	SAI1_TXD2	VSS																				
SAI3_RXD	NVCC_SAI3	SAI3_MCLK	SAI3_TXD	SAI1_TXD6	SAI1_MCLK																				
SAI3_RXC	VSS	ECSP1_SS0	SAI3_TXC	ECSP11_MISO	ECSP11_MOSI																				
NVCC_ECSP1	ECSP12_MOSI	ECSP11_SCLK	ECSP12_SCLK	ECSP12_MISO	ECSP12_SS0																				
SPDIF_TX	SPDIF_EXT_CLK	UART2_TXD	UART4_RXD	UART2_RXD	UART3_RXD																				
I2C2_SDA	I2C1_SCL	UART4_TXD	UART1_RXD	UART3_TXD	UART1_TXD																				
I2C4_SCL	I2C1_SDA	NVCC_UART	VSS	USB2_RX_N	USB2_RX_P																				
I2C4_SDA	I2C3_SDA	USB2_VBUS	USB2_ID	USB2_TX_N	USB2_TX_P																				
VSS	VSS	VSS	VSS	USB2_DN	USB2_DP																				
USB2_VPH	USB2_DVDD	USB2_VP	USB2_VPTX	USB2_RESREF	USB1_RESREF																				
USB1_VPH	USB1_DVDD	USB1_VP	USB1_VPTX	USB1_RX_N	USB1_RX_P																				
VSS	VSS	VSS	VSS	USB1_TX_N	USB1_TX_P																				
VSS	VSS	USB1_VBUS	USB1_ID	USB1_DN	USB1_DP																				
MIPI_VDD	MIPI_VDD	VSS	VSS	MIPI_DSI_D3_P	MIPI_DSI_D3_N																				
VSS	VSS	MIPI_DSI_CLK_P	MIPI_DSI_CLK_N	MIPI_DSI_D1_P	MIPI_DSI_D1_N																				
MIPI_VDDA	MIPI_VDDA	MIPI_VDDHA	MIPI_DSI_REXT	MIPI_DSI_D0_P	MIPI_DSI_D0_N																				
MIPI_VDDA	MIPI_VDDA	MIPI_VDDHA	MIPI_VDDHA	MIPI_DSI_D2_P	MIPI_DSI_D2_N																				
MIPI_VDDPLL	VSS	MIPI_CSI2_D3_P	MIPI_CSI2_D3_N	MIPI_CSI2_CLK_P	MIPI_CSI2_CLK_N																				
VSS	VSS	MIPI_CSI2_D0_P	MIPI_CSI2_D0_N	MIPI_CSI2_D1_P	MIPI_CSI2_D1_N																				
NAND_CE2_B	VSS	MIPI_CSI1_D3_P	MIPI_CSI1_D3_N	MIPI_CSI2_D2_P	MIPI_CSI2_D2_N																				
PCIE_VP	VSS	MIPI_CSI1_D1_P	MIPI_CSI1_D1_N	MIPI_CSI2_D1_P	MIPI_CSI2_D1_N																				
PCIE_VPTX	VSS	VSS	MIPI_CSI1_D2_P	MIPI_CSI1_D2_P	MIPI_CSI1_D2_N																				
PCIE2_REF_PAD_CLK_N	PCIE2_TXN_N	PCIE2_RXN_N	VSS	MIPI_CSI1_D1_N	MIPI_CSI1_D1_N																				
PCIE2_REF_PAD_CLK_P	PCIE2_TXN_P	PCIE2_RXN_P	PCIE2_RESREF	MIPI_CSI1_D2_P	MIPI_CSI1_D2_P																				

Table 86. 17 x 17 mm, 0.65 mm pitch ball map (continued)

M	L	K	J	H	G
HDMI_TX_P_LN_3	SAI1_RXFS	SAI1_RXC	SAI1_RXD4	SAI1_TXFS	SAI1_RXD7
HDMI_TX_M_LN_3	SAI1_RXD1	SAI1_RXD0	SAI1_RXD3	SAI1_RXD2	SAI1_RXD6
NVCC_SAI5	NVCC_SAI1	NVCC_SAI1	VSS	SAI2_RXC	SAI3_TXFS
SAI5_RXD2	SAI5_RXD1	SAI5_MCLK	SAI2_RXFS	SAI2_TXFS	SAI3_RXFS
SAI5_RXD0	SAI5_RXC	SAI5_RXD3	SAI2_TXC	SAI2_MCLK	SAI2_TXD0
GPIO1_IO09	GPIO1_IO11	GPIO1_IO13	GPIO1_IO15	SAI2_RXD0	SPDIF_RX
GPIO1_IO10	GPIO1_IO12	GPIO1_IO14	NVCC_SAI2	NVCC_I2C	I2C2_SCL
VSS	VSS	VSS	VSS	VSS	I2C3_SCL
VDD_GPU	VDD_GPU	VDD_GPU	VDD_GPU	VSS	VSS
VDD_GPU	VDD_GPU	VDD_GPU	VDD_GPU	VSS	VSS
VSS	VSS	VSS	VSS	VSS	USB2_VDD33
VDD_SOC	VDD_SOC	VDD_SOC	VSS	VSS	USB1_VDD33
VDD_SOC	VDD_SOC	VSSA_FPLL_ARM	VSS	VSS	VSS
VSS	VSS	VDDA_1P8_FPLL-ARM	VSS	VDD_ARM	VDD_ARM
VDD_ARM	VDD_ARM	VDD_ARM	VDD_ARM	VDD_ARM	VDD_ARM
VDD_ARM	VDD_ARM	VDD_ARM	VDD_ARM	VDD_ARM	VDD_ARM
VSS	VSS	VSS	VSS	VSS	VSS
NVCC_NAND	NVCC_NAND	VSS	VSS	VSS	VSS
NAND_DATA07	NAND_DATA06	NAND_RE_B	VSS	NAND_CEO_B	NAND_ALE
NAND_DQS	NAND_DATA04	NAND_READY_B	NAND_DATA01	NAND_CE3_B	NAND_DATA00
SD2_WP	SD2_CD_B	NAND_WP_B	NAND_DATA03	NAND_CLE	NAND_CE1_B
SD2_CMD	SD2_CLK	NAND_WE_B	NAND_DATA05	NAND_DATA02	PCIE_VP
NVCC_SD1	NVCC_SD1	VSS	PCIE_VPH	PCIE_VPH	PCIE_VPTX
SD1_DATA1	SD1_CMD	PCIE1_REF_PAD_CLK_N	PCIE1_TXN_N	PCIE1_RXN_N	VSS
SD1_DATA0	SD1_CLK	PCIE1_REF_PAD_CLK_P	PCIE1_TXN_P	PCIE1_RXN_P	PCIE1_RESREF

Table 86. 17 x 17 mm, 0.65 mm pitch ball map (continued)

V	U	T	R	P	N
HDMI_AUX_P	HDMI_TX_M_LN_1	HDMI_TX_P_LN_0	HDMI_REFCLK_N	HDMI_REXT	HDMI_TX_M_LN_2
HDMI_AUX_N	HDMI_TX_P_LN_1	HDMI_TX_M_LN_0	HDMI_REFCLK_P	HDMI_AVDDIO	HDMI_TX_P_LN_2
HDMI_AVDDCLK	HDMI_AVDDCORE	VSS	HDMI_DDC_SCL	HDMI_DDC_SDA	VSS
VSS	HDMI_AVDDCORE	VSS	GPIO1_IO02	GPIO1_IO03	SAI5_RXFS
JTAG_TMS	JTAG_TDO	JTAG_TCK	NVCC_GPIO1	GPIO1_IO04	GPIO1_IO06
BOOT_MODE1	JTAG_TRST_B	GPIO1_IO00	NVCC_GPIO1	VSS	GPIO1_IO07
TEST_MODE	JTAG_MOD	GPIO1_IO01	VSS	GPIO1_IO05	GPIO1_IO08
VSS	VSS	VDD_SOC	VDD_SOC	VSS	VDD_VPU
VDD_DRAM	VSS	VSS	VDD_SOC	VDD_VPU	VDD_VPU
VDD_DRAM	VDD_DRAM	VSS	VDD_SOC	VDD_VPU	VDD_VPU
VDD_DRAM	VDD_DRAM	VSS	VDD_SOC	VSS	VDDA_1P8_SPLL_VIDEO2
VDD_DRAM	VDD_DRAM	VSS	VDD_SOC	VDD_SOC	VSSA_SPLL_VIDEO2
VDD_DRAM	VDD_DRAM	VSS	VDD_SOC	VDD_SOC	VDD_SOC
VDD_DRAM	VDD_DRAM	VSSA_SPLL_DRAM	VDD_SOC	VSS	VSS
VDD_DRAM	VSS	VDDA_1P8_SPLL_DRAM	VDD_SOC	VDD_SOC	VSS
VSS	VSSA_FPLL	VDDA_1P8_TSENSOR	VDD_SOC	VDD_SOC	VSS
VSSA_SPLL	VDDA_1P8_FPLL	VDD_SOC	EFUSE_VQPS	VSS	VSS
VDDA_0P9	VSS	NVCC_ENET	VDD_SNVS	VSS	VSS
ENET_RD3	ENET_RD0	ENET_TXC	ENET_TD2	ENET_TX_CTL	ENET_MDIO
PMIC_ON_REQ	ENET_RD2	ENET_RXC	ENET_TD0	ENET_TD3	ENET_MDC
PMIC_STBY_REQ	ENET_RD1	ENET_RX_CTL	ENET_TD1	SD2_DATA3	SD2_DATA1
RTC	CLK2_N	CLK2_P	SD2_RESET_B	SD2_DATA2	SD2_DATA0
VSSA_XTAL_25M	VDDA_1P8_LVDS	CLK1_N	CLK1_P	VSS	NVCC_SD2
XTALO_27M	XTALO_25M	SD1_STROBE	SD1_RESET_B	SD1_DATA5	SD1_DATA4
XTALI_27M	XTALI_25M	SD1_DATA7	SD1_DATA6	SD1_DATA3	SD1_DATA2

Table 86. 17 x 17 mm, 0.65 mm pitch ball map (continued)

AE	AD	AC	AB	AA	Y	W
	VSS	DRAM_DQS2_N	DRAM_DQ23	DRAM_DQ22	DRAM_DQ21	VSS
VSS	DRAM_DQ17	DRAM_DQS2_P	VSS	DRAM_DQ20	VSS	HDMI_HPD
DRAM_DQ16	DRAM_DM2	NVCC_DRAM	NVCC_DRAM	DRAM_DQ26	VSS	HDMI_CEC
DRAM_DQ18	DRAM_DQ19	VSS	DRAM_DQ24	DRAM_DQ25	VSS	NVCC_JTAG
VSS	NVCC_DRAM	DRAM_DQS3_N	DRAM_DQS3_P	VSS	VSS	JTAG_TDI
DRAM_AC30	DRAM_AC31	NVCC_DRAM	DRAM_DM3	DRAM_DQ27	VDD_DRAM	BOOT_MODE0
DRAM_AC29	VSS	DRAM_AC28	DRAM_DQ29	DRAM_DQ30	VSS	VSS
DRAM_AC32	DRAM_AC22	NVCC_DRAM	NVCC_DRAM	DRAM_DQ28	VDD_DRAM	VSS
DRAM_AC33	VSS	DRAM_AC23	VSS	DRAM_DQ31	VSS	VSS
DRAM_AC21	DRAM_AC20	DRAM_AC34	DRAM_AC35	NVCC_DRAM	VDD_DRAM	VSS
DRAM_AC37	VSS	DRAM_AC38	VSS	VDDA_DRAM	VSS	VSS
DRAM_AC25	DRAM_AC24	DRAM_AC36	DRAM_AC26	DRAM_AC27	NVCC_DRAM	VSS
DRAM_AC06	VSS	DRAM_ALERT_N	DRAM_RESET_N	DRAM_ZN	VSS	VSS
DRAM_AC05	DRAM_AC04	NVCC_DRAM	DRAM_AC19	DRAM_VREF	NVCC_DRAM	VSS
DRAM_AC16	DRAM_AC17	DRAM_AC15	DRAM_AC07	NVCC_DRAM	VSS	VSS
DRAM_AC09	VSS	DRAM_AC00	DRAM_AC14	VSS	VDD_DRAM	VSS
DRAM_AC01	DRAM_AC08	NVCC_DRAM	NVCC_DRAM	DRAM_DQ15	VSS	VDDA_1P8_SPLL
DRAM_AC02	NVCC_DRAM	DRAM_AC03	VSS	DRAM_DQ12	VDD_DRAM	NVCC_SNVS
DRAM_AC13	DRAM_AC12	VSS	DRAM_DQ13	DRAM_DQ14	VSS	RTC_RESET_B
DRAM_AC11	DRAM_AC10	NVCC_DRAM	DRAM_DM1	DRAM_DQ11	VDD_DRAM	POR_B
VSS	NVCC_DRAM	DRAM_DQS1_N	DRAM_DQS1_P	VSS	VSS	ONOFF
DRAM_DQ02	DRAM_DQ03	VSS	DRAM_DQ08	DRAM_DQ09	VSS	VSSA_XTAL_27M
DRAM_DQ00	DRAM_DM0	NVCC_DRAM	NVCC_DRAM	DRAM_DQ10	VSS	VDDA_1P8_XTAL_27M
VSS	DRAM_DQ01	DRAM_DQS0_P	VSS	DRAM_DQ04	VSS	VDDA_1P8_XTAL_25M
	VSS	DRAM_DQS0_N	DRAM_DQ07	DRAM_DQ06	DRAM_DQ05	VSS

5.2 DDR pin function list for 17 x 17 mm package

Table 87 shows the DDR pin function list for 17 x 17 mm package.

Table 87. DDR pin function list for 17 x 17 mm package

Die level pin name	LPDDR4	DDR4	DDR3L	BALL
DRAM_DQS0_P	DQS0_t_A	DQSL_t_A	DQSL_A	AC24
DRAM_DQS0_N	DQS0_c_A	DQSL_c_A	DQSL#_A	AC25
DRAM_DM0	DMI0_A	DML_n_A / DBIL_n_A	DML_A	AD23
DRAM_DQ00	DQ0_A	DQL0_A	DQL0_A	AE23
DRAM_DQ01	DQ1_A	DQL1_A	DQL1_A	AD24
DRAM_DQ02	DQ2_A	DQL2_A	DQL2_A	AE22
DRAM_DQ03	DQ3_A	DQL3_A	DQL3_A	AD22
DRAM_DQ04	DQ4_A	DQL4_A	DQL4_A	AA24
DRAM_DQ05	DQ5_A	DQL5_A	DQL5_A	Y25
DRAM_DQ06	DQ6_A	DQL6_A	DQL6_A	AA25
DRAM_DQ07	DQ7_A	DQL7_A	DQL7_A	AB25
DRAM_DQS1_P	DQS1_t_A	DQSU_t_A	DQSU_A	AB21
DRAM_DQS1_N	DQS1_c_A	DQSU_c_A	DQSU#_A	AC21
DRAM_DM1	DMI1_A	DMU_n_A / DBIU_n_A	DMU_A	AB20
DRAM_DQ08	DQ08_A	DQU0_A	DQU0_A	AB22
DRAM_DQ09	DQ09_A	DQU1_A	DQU1_A	AA22
DRAM_DQ10	DQ10_A	DQU2_A	DQU2_A	AA23
DRAM_DQ11	DQ11_A	DQU3_A	DQU3_A	AA20
DRAM_DQ12	DQ12_A	DQU4_A	DQU4_A	AA18
DRAM_DQ13	DQ13_A	DQU5_A	DQU5_A	AB19
DRAM_DQ14	DQ14_A	DQU6_A	DQU6_A	AA19
DRAM_DQ15	DQ15_A	DQU7_A	DQU7_A	AA17
DRAM_DQS2_P	DQS0_t_B	DQSL_t_B	DQSL_B	AC2
DRAM_DQS2_N	DQS0_c_B	DQSL_c_B	DQSL#_B	AC1
DRAM_DM2	DMI0_B	DML_n_B / DBIL_n_B	DML_B	AD3
DRAM_DQ16	DQ0_B	DQL0_B	DQL0_B	AE3
DRAM_DQ17	DQ1_B	DQL1_B	DQL1_B	AD2
DRAM_DQ18	DQ2_B	DQL2_B	DQL2_B	AE4
DRAM_DQ19	DQ3_B	DQL3_B	DQL3_B	AD4
DRAM_DQ20	DQ4_B	DQL4_B	DQL4_B	AA2
DRAM_DQ20	DQ4_B	DQL4_B	DQL4_B	AA2

Table 87. DDR pin function list for 17 x 17 mm package (continued)

DRAM_DQ21	DQ5_B	DQL5_B	DQL5_B	Y1
DRAM_DQ22	DQ6_B	DQL6_B	DQL6_B	AA1
DRAM_DQ23	DQ7_B	DQL7_B	DQL7_B	AB1
DRAM_DQS3_P	DQS1_t_B	DQSU_t_B	DQSU_B	AB5
DRAM_DQS3_N	DQS1_c_B	DQSU_c_B	DQSU#_B	AC5
DRAM_DM3	DMI1_B	DMU_n_B / DBIU_n_B	DMU_B	AB6
DRAM_DQ24	DQ08_B	DQU0_B	DQU0_B	AB4
DRAM_DQ25	DQ09_B	DQU1_B	DQU1_B	AA4
DRAM_DQ26	DQ10_B	DQU2_B	DQU2_B	AA3
DRAM_DQ27	DQ11_B	DQU3_B	DQU3_B	AA6
DRAM_DQ28	DQ12_B	DQU4_B	DQU4_B	AA8
DRAM_DQ29	DQ13_B	DQU5_B	DQU5_B	AB7
DRAM_DQ30	DQ14_B	DQU6_B	DQU6_B	AA7
DRAM_DQ31	DQ15_B	DQU7_B	DQU7_B	AA9
DRAM_RESET_N	RESET_N	RESET_N	RESET#	AB13
DRAM_ALERT_N	MTEST1	ALERT_n / MTEST1	MTEST1	AC13
DRAM_AC00	CKE0_A	CKE0	CKE0	AC16
DRAM_AC01	CKE1_A	CKE1	CKE1	AE17
DRAM_AC02	CS0_A	CS0_n	CS0#	AE18
DRAM_AC03	CS1_A	C0	—	AC18
DRAM_AC04	CK_t_A	BG0	BA2	AD14
DRAM_AC05	CK_c_A	BG1	A14	AE14
DRAM_AC06	—	ACT_n	A15	AE13
DRAM_AC07	—	A9	A9	AB15
DRAM_AC08	CA0_A	A12	A12 / BC#	AD17
DRAM_AC09	CA1_A	A11	A11	AE16
DRAM_AC10	CA2_A	A7	A7	AD20
DRAM_AC11	CA3_A	A8	A8	AE20
DRAM_AC12	CA4_A	A6	A6	AD19
DRAM_AC13	CA5_A	A5	A5	AE19
DRAM_AC14	—	A4	A4	AB16
DRAM_AC15	—	A3	A3	AC15
DRAM_AC16	—	CK_t_A	CK_A	AE15
DRAM_AC17	—	CK_c_A	CK#_A	AD15

Table 87. DDR pin function list for 17 x 17 mm package (continued)

DRAM_AC19	MTEST	MTEST	MTEST	AB14
DRAM_AC20	CKE0_B	CK_t_B	CK_B	AD10
DRAM_AC21	CKE1_B	CK_c_B	CK#_B	AE10
DRAM_AC22	CS1_B	—	—	AD8
DRAM_AC23	CS0_B	—	—	AC9
DRAM_AC24	CK_t_B	A2	A2	AD12
DRAM_AC25	CK_c_B	A1	A1	AE12
DRAM_AC26	—	BA1	BA1	AB12
DRAM_AC27	—	PARITY	—	AA12
DRAM_AC28	CA2_B	A13	A13	AC7
DRAM_AC29	CA3_B	BA0	BA0	AE7
DRAM_AC30	CA4_B	A10 / AP	A10 / AP	AE6
DRAM_AC31	CA5_B	A0	A0	AD6
DRAM_AC32	CA0_B	C2	—	AE8
DRAM_AC33	CA1_B	CAS_n / A15	CAS#	AE9
DRAM_AC34	—	WE_n / A14	WE#	AC10
DRAM_AC35	—	RAS_n / A16	RAS#	AB10
DRAM_AC36	—	ODT0	ODT0	AC12
DRAM_AC37	—	ODT1	ODT1	AE11
DRAM_AC38	—	CS1_n	CS1#	AC11
DRAM_ZN	ZQ	ZQ	ZQ	AA13
DRAM_VREF	VREF	VREF	VREF	AA14

6 Revision history

Table 88 provides a revision history for this data sheet.

Table 88. Revision history

Rev. number	Date	Substantive change(s)
Rev. 3	04/2021	<ul style="list-style-type: none"> Updated the Fusing option in the Figure 2, "Part number nomenclature—i.MX 8M Dual / 8M QuadLite / 8M Quad processors" Updated the descriptions of SJC in the Table 3, "i.MX 8M Dual / 8M QuadLite / 8M Quad modules list" Updated the descriptions of PCIE_VPH in the Table 8, "Operating ranges"
Rev. 2	10/2020	<ul style="list-style-type: none"> Removed four part numbers in the Table 2, "Orderable part numbers"; added part differentiator, a new part number, and a footnote in the Table 2, "Orderable part numbers" Updated the Part differentiator and Fusing option in the Figure 2, "Part number nomenclature—i.MX 8M Dual / 8M QuadLite / 8M Quad processors" Updated the minimum values and removed ESD parameters from Table 5, "Absolute maximum ratings" Added the Table 6, "Electrostatic discharge and latch up ratings" Added a new Section 3.1.3, Power architecture Added a footnote and updated the comment of temperature sensor accuracy in the Table 8, "Operating ranges" Updated the maximum value of V_{IH} in the Table 57, "MIPI low power receiver DC specifications" Removed the Section, USB battery charger detection drive impedance Removed the Section, USB_OTG_CHD_B USB battery charger detection external pullup resistor connection
Rev. 1.1	05/2019	<ul style="list-style-type: none"> Updated the package type information in the Figure 2, "Part number nomenclature—i.MX 8M Dual / 8M QuadLite / 8M Quad processors" Updated eCSPI description in the Table 3, "i.MX 8M Dual / 8M QuadLite / 8M Quad modules list" Added the core voltage, analog domain voltage, PLL 1.8 V voltage, 25 MHz crystal voltage, 27 MHz crystal voltage, DDR I/O voltage, HDMI voltage, MIPI voltage, PCIe voltage, temperature sensor voltage, and fuse power in the Table 5, "Absolute maximum ratings" Updated the Table 7, "Thermal resistance data" Updated the RUN mode unit in the Table 11, "Chip power in different LP mode"
Rev. 1	10/2018	<ul style="list-style-type: none"> Updated the Table 2, "Orderable part numbers" Updated the Figure 2, "Part number nomenclature—i.MX 8M Dual / 8M QuadLite / 8M Quad processors"
Rev. 0.2	08/2018	<ul style="list-style-type: none"> Updated the Table 8, "Operating ranges" Updated the Section 3.1.5, External clock sources Updated the Section 3.1.6, Maximum supply currents Updated the Section 3.2.1, Power-up sequence Updated the Figure 6, "Differential LVDS driver transition time waveform" Updated the Section 3.9.3.1, RMII mode timing Updated the Section 5.1.2, 17 x 17 mm supplies contact assignments and functional contact assignments Fixed a typo in the Table 86, "17 x 17 mm, 0.65 mm pitch ball map"

Revision history

Table 88. Revision history (continued)

Rev. number	Date	Substantive change(s)
Rev. 0.1	05/2018	<ul style="list-style-type: none"> • Added a note in the Table 2, "Orderable part numbers" • Updated the Table 3, "i.MX 8M Dual / 8M QuadLite / 8M Quad modules list" • Updated the Table 8, "Operating ranges" • Updated the Table 10, "Maximum supply currents" • Updated the Table 11, "Chip power in different LP mode" • Added the Table 12, "The power supply states" • Updated the PCIe parameters in the Table 16, "PCIe recommended operating conditions" • Updated and added a leakage limit note in the Table 27, "GPIO DC parameters" • Added a leakage limit note in the Table 30, "Input DC current" • Updated the timing parameters in the Table 39, "ECSPI Master mode timing parameters" and Table 40, "ECSPI Slave mode timing parameters" • Updated the Section 3.9.8.1, PCIEx_RESREF reference resistor connection • Updated the Table 60, "MIPI input characteristics DC specifications" • Removed the SPI interfaces from the Table 83, "Interface allocation during boot" • Updated the PCIe and MIPI power group in the Table 85, "i.MX 8M Dual / 8M QuadLite / 8M Quad 17 x 17 mm functional contact assignments" • Updated the Table 86, "17 x 17 mm, 0.65 mm pitch ball map"
Rev. 0	01/2018	<ul style="list-style-type: none"> • Initial version

How To Reach Us

Home Page:

nxp.com

Web Support:

nxp.com/support

Limited warranty and liability — Information in this document is believed to be accurate and reliable. However, NXP Semiconductors does not give any representations or warranties, expressed or implied, as to the accuracy or completeness of such information and shall have no liability for the consequences of use of such information. NXP Semiconductors takes no responsibility for the content in this document if provided by an information source outside of NXP Semiconductors. In no event shall NXP Semiconductors be liable for any indirect, incidental, punitive, special or consequential damages (including - without limitation - lost profits, lost savings, business interruption, costs related to the removal or replacement of any products or rework charges) whether or not such damages are based on tort (including negligence), warranty, breach of contract or any other legal theory.

Notwithstanding any damages that customer might incur for any reason whatsoever, NXP Semiconductors' aggregate and cumulative liability towards customer for the products described herein shall be limited in accordance with the Terms and conditions of commercial sale of NXP Semiconductors.

Right to make changes - NXP Semiconductors reserves the right to make changes to information published in this document, including without limitation specifications and product descriptions, at any time and without notice. This document supersedes and replaces all information supplied prior to the publication hereof.

Security — Customer understands that all NXP products may be subject to unidentified or documented vulnerabilities. Customer is responsible for the design and operation of its applications and products throughout their lifecycles to reduce the effect of these vulnerabilities on customer's applications and products. Customer's responsibility also extends to other open and/or proprietary technologies supported by NXP products for use in customer's applications. NXP accepts no liability for any vulnerability. Customer should regularly check security updates from NXP and follow up appropriately.

Customer shall select products with security features that best meet rules, regulations, and standards of the intended application and make the ultimate design decisions regarding its products and is solely responsible for compliance with all legal, regulatory, and security related requirements concerning its products, regardless of any information or support that may be provided by NXP. NXP has a Product Security Incident Response Team (PSIRT) (reachable at PSIRT@nxp.com) that manages the investigation, reporting, and solution release to security vulnerabilities of NXP products.

Suitability for use in automotive applications — This NXP Semiconductors product has been qualified for use in automotive applications. Unless otherwise agreed in writing, the product is not designed, authorized or warranted to be suitable for use in life support, life-critical or safety-critical systems or equipment, nor in applications where failure or malfunction of an NXP Semiconductors product can reasonably be expected to result in personal injury, death or severe property or environmental damage. NXP Semiconductors and its suppliers accept no liability for inclusion and/or use of NXP Semiconductors products in such equipment or applications and therefore such inclusion and/or use is at the customer's own risk.

Non-automotive qualified products — Unless this data sheet expressly states that this specific NXP Semiconductors product is automotive qualified, the product is not suitable for automotive use. It is neither qualified nor tested in accordance with automotive testing or application requirements. NXP Semiconductors accepts no liability for inclusion and/or use of non-automotive qualified products in automotive equipment or applications.

In the event that customer uses the product for design-in and use in automotive applications to automotive specifications and standards, customer (a) shall use the product without NXP Semiconductors' warranty of the product for such automotive applications, use and specifications, and (b) whenever customer uses the product for automotive applications beyond NXP Semiconductors' specifications such use shall be solely at customer's own risk, and (c) customer fully indemnifies NXP Semiconductors for any liability, damages or failed product claims resulting from customer design and use of the product for automotive applications beyond NXP Semiconductors' standard warranty and NXP Semiconductors' product specifications.

Suitability for use – Automotive Product (Functional Safety) Suitability for use in automotive applications — This NXP product has been qualified for use in automotive applications. It has been developed in accordance with ISO 26262, and has been ASIL-classified accordingly. If this product is used by customer in the development of, or for incorporation into, products or services (a) used in safety critical applications or (b) in which failure could lead to death, personal injury, or severe physical or environmental damage (such products and services hereinafter referred to as "Critical

Table continues on the next page...

Applications"), then customer makes the ultimate design decisions regarding its products and is solely responsible for compliance with all legal, regulatory, safety, and security related requirements concerning its products, regardless of any information or support that may be provided by NXP. As such, customer assumes all risk related to use of any products in Critical Applications and NXP and its suppliers shall not be liable for any such use by customer. Accordingly, customer will indemnify and hold NXP harmless from any claims, liabilities, damages and associated costs and expenses (including attorneys' fees) that NXP may incur related to customer's incorporation of any product in a Critical Application.

Non-automotive products for restricted use in automotive only Suitability for use in automotive applications — The use of this NXP Semiconductors product is restricted to automotive applications only. It has not been fully qualified for use in automotive applications. The customer of this NXP Semiconductors product therefore understands and accepts that:

- The Customer shall only use this NXP Semiconductors product for automotive applications.
- This product was not originally designed for automotive use. It will therefore, not be possible to achieve the levels of quality and failure analysis that are normally associated with products explicitly designed for automotive use.
- With respect to test-coverage, this product is not fully compliant to AEC-Q100.
- All product manufacturing locations are certified according to ISO/TS16949.
- Unless otherwise agreed in writing, the product is not designed, authorized or warranted to be suitable for use in life support, life-critical or safety-critical systems or equipment, nor in applications where failure or malfunction of an NXP Semiconductors product can reasonably be expected to result in personal injury, death or severe property or environmental damage. NXP Semiconductors and its suppliers accept no liability for inclusion and/or use of NXP Semiconductors products in such equipment or applications and therefore such inclusion and/or use is at the customer's own risk.

Applications — Applications that are described herein for any of these products are for illustrative purposes only. NXP Semiconductors makes no representation or warranty that such applications will be suitable for the specified use without further testing or modification.

Customers are responsible for the design and operation of their applications and products using NXP Semiconductors products, and NXP Semiconductors accepts no liability for any assistance with applications or customer product design. It is customer's sole responsibility to determine whether the NXP Semiconductors product is suitable and fit for the customer's applications and products planned, as well as for the planned application and use of customer's third party customer(s). Customers should provide appropriate design and operating safeguards to minimize the risks associated with their applications and products.

NXP Semiconductors does not accept any liability related to any default, damage, costs or problem which is based on any weakness or default in the customer's applications or products, or the application or use by customer's third party customer(s). Customer is responsible for doing all necessary testing for the customer's applications and products using NXP Semiconductors products in order to avoid a default of the applications and the products or of the application or use by customer's third party customer(s). NXP does not accept any liability in this respect.

Limiting values — Stress above one or more limiting values (as defined in the Absolute Maximum Ratings System of IEC 60134) will cause permanent damage to the device. Limiting values are stress ratings only and (proper) operation of the device at these or any other conditions above those given in the Recommended operating conditions section (if present) or the Characteristics sections of this document is not warranted. Constant or repeated exposure to limiting values will permanently and irreversibly affect the quality and reliability of the device.

Terms and conditions of commercial sale — NXP Semiconductors products are sold subject to the general terms and conditions of commercial sale, as published at <http://www.nxp.com/profile/terms>, unless otherwise agreed in a valid written individual agreement. In case an individual agreement is concluded only the terms and conditions of the respective agreement shall apply. NXP Semiconductors hereby expressly objects to applying the customer's general terms and conditions with regard to the purchase of NXP Semiconductors products by customer.

Table continues on the next page...

No offer to sell or license — Nothing in this document may be interpreted or construed as an offer to sell products that is open for acceptance or the grant, conveyance or implication of any license under any copyrights, patents or other industrial or intellectual property rights.

Hazardous voltage — Although basic supply voltages of the product may be much lower, circuit voltages up to 60 V may appear when operating this product, depending on settings and application. Customers incorporating or otherwise using these products in applications where such high voltages may appear during operation, assembly, test etc, of such application, do so at their own risk. Customers agree to fully indemnify NXP Semiconductors for any damages resulting from or in connection with such high voltages. Furthermore, customers are drawn to safety standards (IEC 950, EN 60 950, CENELEC, ISO, etc.) and other (legal) requirements applying to such high voltages.

Bare die — All die are tested on compliance with their related technical specifications as stated in this data sheet up to the point of wafer sawing and are handled in accordance with the NXP Semiconductors storage and transportation conditions. If there are data sheet limits not guaranteed, these will be separately indicated in the data sheet. There are no post-packing tests performed on individual die or wafers.

NXP Semiconductors has no control of third party procedures in the sawing, handling, packing or assembly of the die. Accordingly, NXP Semiconductors assumes no liability for device functionality or performance of the die or systems after third party sawing, handling, packing or assembly of the die. It is the responsibility of the customer to test and qualify their application in which the die is used. All die sales are conditioned upon and subject to the customer entering into a written die sale agreement with NXP Semiconductors through its legal department.

Quick reference data — The Quick reference data is an extract of the product data given in the Limiting values and Characteristics sections of this document, and as such is not complete, exhaustive or legally binding.

Export control — This document as well as the item(s) described herein may be subject to export control regulations. Export might require a prior authorization from competent authorities.

Evaluation products — This product is provided on an “as is” and “with all faults” basis for evaluation purposes only. NXP Semiconductors, its affiliates and their suppliers expressly disclaim all warranties, whether express, implied or statutory, including but not limited to the implied warranties of non-infringement, merchantability and fitness for a particular purpose. The entire risk as to the quality, or arising out of the use or performance, of this product remains with customer. In no event shall NXP Semiconductors, its affiliates or their suppliers be liable to customer for any special, indirect, consequential, punitive or incidental damages (including without limitation damages for loss of business, business interruption, loss of use, loss of data or information, and the like) arising out of the use of or inability to use the product, whether or not based on tort (including negligence), strict liability, breach of contract, breach of warranty or any other theory, even if advised of the possibility of such damages.

Notwithstanding any damages that customer might incur for any reason whatsoever (including without limitation, all damages referenced above and all direct or general damages), the entire liability of NXP Semiconductors, its affiliates and their suppliers and customer’s exclusive remedy for all of the foregoing shall be limited to actual damages incurred by customer based on reasonable reliance up to the greater of the amount actually paid by customer for the product or five dollars (US\$5,00). The foregoing limitations, exclusions and disclaimers shall apply to the maximum extent permitted by applicable law, even if any remedy fails of its essential purpose.

Translations — A non-English (translated) version of a document is for reference only. The English version shall prevail in case of any discrepancy between the translated and English versions.

NXP, the NXP logo, NXP SECURE CONNECTIONS FOR A SMARTER WORLD, COOLFLUX, EMBRACE, GREENCHIP, HITAG, ICODE, JCOP, LIFE, VIBES, MIFARE, MIFARE CLASSIC, MIFARE DESFire, MIFARE PLUS, MIFARE FLEX, MANTIS, MIFARE ULTRALIGHT, MIFARE4MOBILE, MIGLO, NTAG, ROADLINK, SMARTLX, SMARTMX, STARPLUG, TOPFET, TRENCHMOS, UCODE, Freescale, the Freescale logo, CodeWarrior, ColdFire, ColdFire+, the Energy Efficient Solutions logo, Kinetis, Layerscape, mobileGT, PEG, PowerQUICC, Processor Expert, QorIQ, QorIQ Qonverge, SafeAssure, the SafeAssure logo, StarCore, Symphony, VortiQa, Vybrid, Airfast, BeeKit, BeeStack, CoreNet, Flexis, MXC, Platform in a Package, QUICC Engine, Tower, TurboLink, EdgeScale, EdgeLock, eIQ, and Immersive3D are trademarks of NXP B.V. All other product or service names are the property of their respective owners. AMBA, Arm, Arm7, Arm7TDMI, Arm9, Arm11, Artisan, big.LITTLE, Cordio, CoreLink, CoreSight,

Table continues on the next page...

Cortex, DesignStart, DynamIQ, Jazelle, Keil, Mali, Mbed, Mbed Enabled, NEON, POP, RealView, SecurCore, Socrates, Thumb, TrustZone, ULINK, ULINK2, ULINK-ME, ULINK-PLUS, ULINKpro, μ Vision, Versatile are trademarks or registered trademarks of Arm Limited (or its subsidiaries) in the US and/or elsewhere. The related technology may be protected by any or all of patents, copyrights, designs and trade secrets. All rights reserved. Oracle and Java are registered trademarks of Oracle and/or its affiliates. M, M Mobileye and other Mobileye trademarks or logos appearing herein are trademarks of Mobileye Vision Technologies Ltd. in the United States, the EU and/or other jurisdictions.

© NXP B.V. 2018-2021.

All rights reserved.

For more information, please visit: <http://www.nxp.com>

For sales office addresses, please send an email to: salesaddresses@nxp.com

Date of release: 13 April 2021

Document Identifier: IMX8MDQLQCEC

The logo for Arm, consisting of the lowercase letters 'arm' in a blue, sans-serif font.