

5W CONVECTION COOLED

AC-DC POWER SUPPLIES

The EME05 is a series of open frame and encapsulated AC-DC single output power supplies designed for medical applications. The series provides two mechanical options including open frame and encapsulated PCB mount. With approvals to world-wide medical safety standards, compliance with class B for both conducted and radiated emissions and a 130%, 30s peak load capability, these class II isolation parts benefit system designers with easy integration into the latest healthcare products and applications.



Features

- Compact Size
- Medical Approvals (2 x MOPP)
- Single Outputs from 3.3 to 48VDC
- Open Frame & Encapsulated PCB Mount
- Class II
- Peak Load Capability
- No External Components Required
- 3 Year Warranty

Applications



Healthcare



Home Healthcare



Medical Diagnostic

Dimensions

EME05:

1.50 x 1.00 x 0.60" (36.1 x 25.4 x 15.2 mm)

EME05-P:

1.40 x 0.94 x 0.69" (35.6 x 23.7 x 17.6 mm)

Models & Ratings

Model Number ⁽²⁾	Output Voltage	Output Current		Output Power
		Nominal	Peak ⁽¹⁾	
EME05US03	3.3VDC	1510mA	1960mA	5W
EME05US05	5.0VDC	1000mA	1300mA	5W
EME05US09	9.0VDC	555mA	722mA	5W
EME05US12	12.0VDC	416mA	541mA	5W
EME05US15	15.0VDC	333mA	433mA	5W
EME05US24	24.0VDC	208mA	270mA	5W
EME05US36	36.0VDC	138mA	180mA	5W
EME05US48	48.0VDC	104mA	135mA	5W

Notes:

1. Peak load lasting <30s with a maximum duty cycle of 10%, average output power not to exceed nominal.
2. For Open Frame version add suffix -P to model number, e.g. EME05US12-P.

Summary

Characteristic	Minimum	Typical	Maximum	Units	Notes & Conditions
Input Voltage Range	85		264	VAC	Derate from 100% at 90VAC to 90% at 85VAC
No Load Input Power			0.3	W	
Efficiency	72		86	%	
Operating Temperature	-25		+70	°C	Derate linearly from 100% at +50°C to 50% at +70°C
EMC	EN55011 Level B Conducted & Radiated, EN601000-3-2, EN61000-3-3, EN60601-1-2				
Safety Approvals	EN60601-1, ANSI/AAMI ES60601-1, IEC60601-1				

Input

Characteristic	Minimum	Typical	Maximum	Units	Notes & Conditions
Input Voltage Range	85		264	VAC	
Input Frequency	47		63	Hz	
Input Current - Full Load		0.10/0.06		A rms	At 115/230VAC
No Load Input Power			0.3	W	
Inrush Current			40	A	At 230VAC
Earth Leakage Current					Class II construction no earth
Input Protection	Internal T1.0 A/250 VAC fuse fitted in line and neutral				

Output

Characteristic	Minimum	Typical	Maximum	Units	Notes & Conditions
Output Voltage	3.3		48	VDC	
Initial Set Accuracy			±1	%	
Minimum Load	0			A	No minimum load required
Line Regulation			±0.5	%	3% for 03 & 05 models, 2% for others from 10% to 100% load
Load Regulation			±1		
Start Up Delay			2	s	
Start Up Rise Time			14	ms	
Hold Up Time	12			ms	At full load and 115VAC
Transient Response			4	%	Deviation, recovery within 1% in less than 500µs for a 25% load change
Ripple & Noise			50	mV pk-pk	3.3-5V, 20MHz bandwidth
			90		9V versions, 20MHz bandwidth
			120		12-15V versions, 20MHz bandwidth
			200		24-48V versions, 20MHz bandwidth
Overvoltage Protection	115		140	% Vnom	Recycle input to reset
Overload Protection	130		200	%	
Short Circuit Protection					Trip & Restart (hiccup mode)
Temperature Coefficient			0.05	%/°C	

General

Characteristic	Minimum	Typical	Maximum	Units	Notes & Conditions
Efficiency		80		%	
Isolation: Input to Output	4000			VAC	2 x MOPP
Switching Frequency		130		kHz	
Power Density			5.5	W/in ³	
Mean Time Between Failure		>400		khrs	MIL-HDBK-217F, +25°C GB
Weight		0.03 (14)		lb (g)	Open frame versions (-P)
		0.053 (24)			Encapsulated version

Environmental

Characteristic	Minimum	Typical	Maximum	Units	Notes & Conditions
Operating Temperature	-25		+70	°C	Derate linearly from 100% at +50°C to 50% at +70°C
Storage Temperature	-40		+85	°C	
Cooling	Convection-cooled				
Humidity			95	%RH	Non-condensing
Operating Altitude			3048	m	
Shock	IEC68-2-27, 30 g, 11 ms half sine, 3 times in each of 6 axes				
Vibration	IEC68-2-6, 2 g, 10Hz to 500kHz, 10 mins/cycle, 60 mins each cycle				

Efficiency Graphs

EME05US12

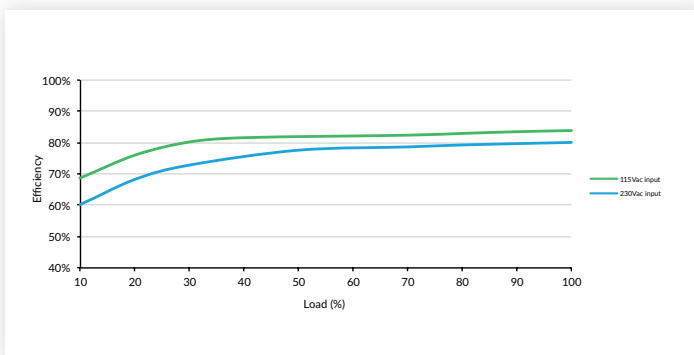

EME05US24

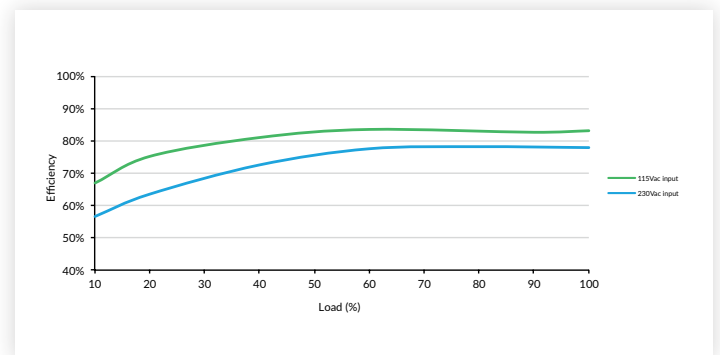

Safety Approvals

Certification	Standard	Notes & Conditions
CB	IEC60601-1	Medical
UL	ANSI/AAMI ES60601-1:2005 & CSA C22.2, No.60601-1:08	
TUV	EN60601-1	
CE	Meets all applicable directives	
UKCA	Meets all applicable legislation	
Means of Protection		Category
Primary to Secondary	2 x MOPP (Means of Patient Protection)	IEC60601-1 Ed 3.1

EMC: Emissions

Phenomenon	Standard	Test Level	Notes & Conditions
Conducted	EN55011	Class B	
Radiated	EN55011	Class B	
Harmonic Current	EN61000-3-2	Class A	
Voltage Flicker	EN61000-3-3		

EMC: Immunity

Phenomenon	Standard	Test Level	Criteria	Notes & Conditions
Medical Device EMC	IEC60601-1-2	Ed 4.0: 2014	A	
ESD Immunity	EN61000-4-2	±6kV contact, ±15kV air discharge	A	
Radiated Immunity	EN61000-4-3	10 V/m	A	80% mod, 80MHz - 2.7GHz plus discrete communication proximity field frequencies
EFT	EN61000-4-4	3	A	
Surge	EN61000-4-5	2	A	
Conducted	EN61000-4-6	10Vrms	A	
Magnetic Fields	EN61000-4-8	30A/m	A	
Dips and Interruptions	EN60601-1-2 (100 VAC)	70% U_T (70 VAC) for 500ms	A	Load de-rated to 50%
		40% U_T (40 VAC) for 100ms	A	
		<5% U_T (0 VAC) for 10ms	A	
		<5% U_T (0 VAC) for 5000ms	B	
	EN60601-1-2 (240 VAC)	70% U_T (168 VAC) for 500ms	A	
		40% U_T (96 VAC) for 100ms	A	
		<5% U_T (0 VAC) for 10ms	A	
		<5% U_T (0 VAC) for 5000ms	B	

Mechanical Details

Encapsulated

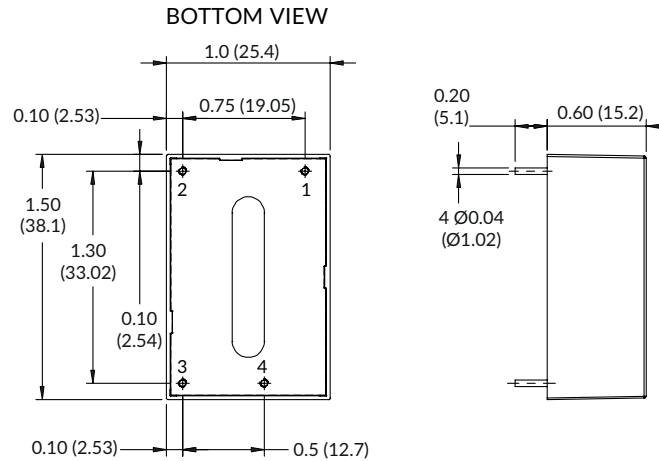

Open Frame (-P)

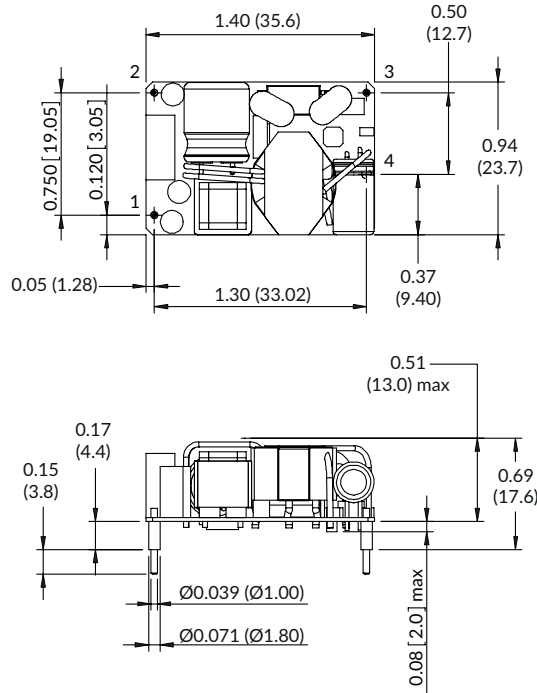

Pin Connections	
Pin	Single
1	ACN
2	ACL
3	-Vout
4	+Vout

Notes:

1. Dimensions in inches (mm).
2. Weight: Open frame versions (-P): 0.03lbs (14g) Encapsulated: 0.053lbs (24g)
3. Tolerances: x.xx = ± 0.02 (x.x = ± 0.5) x.xxx = ± 0.01 (x.xx = ± 0.25)