



**MICROCHIP**

---

**MCP39F501**  
**Power Monitor PICtail™**  
**Evaluation Board**  
**User's Guide**

---

**Note the following details of the code protection feature on Microchip devices:**

- Microchip products meet the specification contained in their particular Microchip Data Sheet.
- Microchip believes that its family of products is one of the most secure families of its kind on the market today, when used in the intended manner and under normal conditions.
- There are dishonest and possibly illegal methods used to breach the code protection feature. All of these methods, to our knowledge, require using the Microchip products in a manner outside the operating specifications contained in Microchip's Data Sheets. Most likely, the person doing so is engaged in theft of intellectual property.
- Microchip is willing to work with the customer who is concerned about the integrity of their code.
- Neither Microchip nor any other semiconductor manufacturer can guarantee the security of their code. Code protection does not mean that we are guaranteeing the product as "unbreakable."

Code protection is constantly evolving. We at Microchip are committed to continuously improving the code protection features of our products. Attempts to break Microchip's code protection feature may be a violation of the Digital Millennium Copyright Act. If such acts allow unauthorized access to your software or other copyrighted work, you may have a right to sue for relief under that Act.

---

Information contained in this publication regarding device applications and the like is provided only for your convenience and may be superseded by updates. It is your responsibility to ensure that your application meets with your specifications. MICROCHIP MAKES NO REPRESENTATIONS OR WARRANTIES OF ANY KIND WHETHER EXPRESS OR IMPLIED, WRITTEN OR ORAL, STATUTORY OR OTHERWISE, RELATED TO THE INFORMATION, INCLUDING BUT NOT LIMITED TO ITS CONDITION, QUALITY, PERFORMANCE, MERCHANTABILITY OR FITNESS FOR PURPOSE. Microchip disclaims all liability arising from this information and its use. Use of Microchip devices in life support and/or safety applications is entirely at the buyer's risk, and the buyer agrees to defend, indemnify and hold harmless Microchip from any and all damages, claims, suits, or expenses resulting from such use. No licenses are conveyed, implicitly or otherwise, under any Microchip intellectual property rights.

**Trademarks**

The Microchip name and logo, the Microchip logo, dsPIC, FlashFlex, flexPWR, JukeBlox, KEELOQ, KEELOQ logo, Kleer, LANCheck, MediaLB, MOST, MOST logo, MPLAB, OptoLyzer, PIC, PICSTART, PIC<sup>32</sup> logo, RightTouch, SpyNIC, SST, SST Logo, SuperFlash and UNI/O are registered trademarks of Microchip Technology Incorporated in the U.S.A. and other countries.

The Embedded Control Solutions Company and mTouch are registered trademarks of Microchip Technology Incorporated in the U.S.A.

Analog-for-the-Digital Age, BodyCom, chipKIT, chipKIT logo, CodeGuard, dsPICDEM, dsPICDEM.net, ECAN, In-Circuit Serial Programming, ICSP, Inter-Chip Connectivity, KleerNet, KleerNet logo, MiWi, MPASM, MPF, MPLAB Certified logo, MPLIB, MPLINK, MultiTRAK, NetDetach, Omniscient Code Generation, PICDEM, PICDEM.net, PICkit, PICtail, RightTouch logo, REAL ICE, SQI, Serial Quad I/O, Total Endurance, TSHARC, USBCheck, VariSense, ViewSpan, WiperLock, Wireless DNA, and ZENA are trademarks of Microchip Technology Incorporated in the U.S.A. and other countries.

SQTP is a service mark of Microchip Technology Incorporated in the U.S.A.

Silicon Storage Technology is a registered trademark of Microchip Technology Inc. in other countries.

GestIC is a registered trademarks of Microchip Technology Germany II GmbH & Co. KG, a subsidiary of Microchip Technology Inc., in other countries.

All other trademarks mentioned herein are property of their respective companies.

© 2014, Microchip Technology Incorporated, Printed in the U.S.A., All Rights Reserved.

ISBN: 978-1-63276-535-2

**QUALITY MANAGEMENT SYSTEM  
CERTIFIED BY DNV  
= ISO/TS 16949 =**

*Microchip received ISO/TS-16949:2009 certification for its worldwide headquarters, design and wafer fabrication facilities in Chandler and Tempe, Arizona; Gresham, Oregon and design centers in California and India. The Company's quality system processes and procedures are for its PIC<sup>®</sup> MCUs and dsPIC<sup>®</sup> DSCs, KEELOQ<sup>®</sup> code hopping devices, Serial EEPROMs, microperipherals, nonvolatile memory and analog products. In addition, Microchip's quality system for the design and manufacture of development systems is ISO 9001:2000 certified.*

---

---

**Object of Declaration:** MCP39F501 Power Monitor PICtail™ Evaluation Board

EU Declaration of Conformity

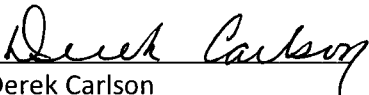
This declaration of conformity is issued by the manufacturer.

The development/evaluation tool is designed to be used for research and development in a laboratory environment. This development/evaluation tool is not intended to be a finished appliance, nor is it intended for incorporation into finished appliances that are made commercially available as single functional units to end users. This development/evaluation tool complies with EU EMC Directive 2004/108/EC and as supported by the European Commission's Guide for the EMC Directive 2004/108/EC (8<sup>th</sup> February 2010).

This development/evaluation tool complies with EU RoHS2 Directive 2011/65/EU.

For information regarding the exclusive, limited warranties applicable to Microchip products, please see Microchip's standard terms and conditions of sale, which are printed on our sales documentation and available at [www.microchip.com](http://www.microchip.com).

Signed for and on behalf of Microchip Technology Inc. at Chandler, Arizona, USA

  
Derek Carlson  
VP Development Tools

16-July-2013  
Date

# MCP39F501 Power Monitor PICtail™ Evaluation Board User's Guide

---

---

NOTES:



# MCP39F501 POWER MONITOR PICTAIL™ EVALUATION BOARD USER'S GUIDE

---

---

## Table of Contents

---

---

<b>Preface</b> .....	<b>3</b>
Introduction.....	3
Document Layout .....	3
Conventions Used in this Guide .....	4
Recommended Reading.....	5
The Microchip Web Site .....	5
Customer Support .....	5
Document Revision History .....	5
<b>Chapter 1. Product Overview</b>	
1.1 Introduction .....	7
1.2 What the MCP39F501 Power Monitor PICtail™ Evaluation Board Kit Includes .....	8
<b>Chapter 2. Installation and Operation</b>	
2.1 Getting Started .....	9
<b>Chapter 3. Hardware</b>	
3.1 Input and Analog Front End .....	12
3.2 Low-Cost Power Supply Circuit .....	13
<b>Appendix A. Schematic and Layouts</b>	
A.1 Introduction .....	15
A.2 Schematics and PCB Layout .....	15
A.3 Board – Schematic 1 .....	16
A.4 Board – Schematic 2 .....	17
A.5 Board – Assembly Top .....	18
A.6 Board – Top Silk .....	19
A.7 Board – Top Copper and Silk .....	20
A.8 Board – Top Copper .....	21
A.9 Board – Bottom Copper .....	22
<b>Appendix B. Bill of Materials</b>	
<b>Worldwide Sales and Service</b> .....	<b>26</b>

# MCP39F501 Power Monitor PICtail™ Evaluation Board User's Guide

---

---

NOTES:



# MCP39F501 POWER MONITOR PICTAIL™ EVALUATION BOARD USER'S GUIDE

---

---

## Preface

---

---

### NOTICE TO CUSTOMERS

All documentation becomes dated, and this manual is no exception. Microchip tools and documentation are constantly evolving to meet customer needs, so some actual dialogs and/or tool descriptions may differ from those in this document. Please refer to our web site ([www.microchip.com](http://www.microchip.com)) to obtain the latest documentation available.

Documents are identified with a “DS” number. This number is located on the bottom of each page, in front of the page number. The numbering convention for the DS number is “DSXXXXXXXXA”, where “XXXXXXXX” is the document number and “A” is the revision level of the document.

For the most up-to-date information on development tools, see the MPLAB® IDE online help. Select the Help menu, and then Topics to open a list of available online help files.

## INTRODUCTION

This chapter contains general information that will be useful to know before using the MCP39F501 Power Monitor PICTail™ Evaluation Board. Items discussed in this chapter include:

- Document Layout
- Conventions Used in this Guide
- Recommended Reading
- The Microchip Web Site
- Customer Support
- Document Revision History

## DOCUMENT LAYOUT

This document describes how to use the MCP39F501 Power Monitor PICTail™ Evaluation Board as a development board for the MCP39F501 device. The manual layout is as follows:

- **Chapter 1. “Product Overview”** – Provides important information about the MCP39F501 Power Monitor PICTail™ Evaluation Board.
- **Chapter 2. “Installation and Operation”** – Provides important information on using the MCP39F501 Power Monitor PICTail™ Evaluation Board including a getting started section that describes wiring the line and load connections.
- **Chapter 3. “Hardware”** – Includes details on the function blocks of the power monitor including the analog front end design, and power supply design.
- **Appendix A. “Schematic and Layouts”** – Shows the schematic and layout diagrams
- **Appendix B. “Bill of Materials (BOM)”** – Lists the parts used to build the MCP39F501 Power Monitor PICTail™ Evaluation Board.

## CONVENTIONS USED IN THIS GUIDE

This manual uses the following documentation conventions:

### DOCUMENTATION CONVENTIONS

Description	Represents	Examples
<b>Arial font:</b>		
Italic characters	Referenced books	<i>MPLAB® IDE User's Guide</i>
	Emphasized text	...is the <i>only</i> compiler...
Initial caps	A window	the Output window
	A dialog	the Settings dialog
	A menu selection	select Enable Programmer
Quotes	A field name in a window or dialog	"Save project before build"
Underlined, italic text with right angle bracket	A menu path	<u><i>File&gt;Save</i></u>
Bold characters	A dialog button	Click <b>OK</b>
	A tab	Click the <b>Power</b> tab
N'Rnnnn	A number in verilog format, where N is the total number of digits, R is the radix and n is a digit.	4'b0010, 2'hF1
Text in angle brackets < >	A key on the keyboard	Press <Enter>, <F1>
<b>Courier New font:</b>		
Plain Courier New	Sample source code	#define START
	Filenames	autoexec.bat
	File paths	c:\mcc18\h
	Keywords	_asm, _endasm, static
	Command-line options	-Opa+, -Opa-
	Bit values	0, 1
	Constants	0xFF, 'A'
Italic Courier New	A variable argument	<i>file.o</i> , where <i>file</i> can be any valid filename
Square brackets [ ]	Optional arguments	mcc18 [options] <i>file</i> [options]
Curly brackets and pipe character: {   }	Choice of mutually exclusive arguments; an OR selection	errorlevel {0 1}
Ellipses...	Replaces repeated text	var_name [, var_name...]
	Represents code supplied by user	void main (void) { ... }



## RECOMMENDED READING

This user's guide describes how to use MCP39F501 Power Monitor PICtail™ Evaluation Board. Another useful documents is listed below. The following Microchip document is available and recommended as a supplemental reference resource.

**MCP39F501 Data Sheet – “Single-Phase Power-Monitoring IC with Calculation and Event Detection” (DS20005256)**

This data sheet provides detailed information regarding the MCP39F501 device.

## THE MICROCHIP WEB SITE

Microchip provides online support via our web site at [www.microchip.com](http://www.microchip.com). This web site is used as a means to make files and information easily available to customers. Accessible by using your favorite Internet browser, the web site contains the following information:

- **Product Support** – Data sheets and errata, application notes and sample programs, design resources, user's guides and hardware support documents, latest software releases and archived software
- **General Technical Support** – Frequently Asked Questions (FAQs), technical support requests, online discussion groups, Microchip consultant program member listing
- **Business of Microchip** – Product selector and ordering guides, latest Microchip press releases, listing of seminars and events, listings of Microchip sales offices, distributors and factory representatives

## CUSTOMER SUPPORT

Users of Microchip products can receive assistance through several channels:

- Distributor or Representative
- Local Sales Office
- Field Application Engineer (FAE)
- Technical Support

Customers should contact their distributor, representative or field application engineer (FAE) for support. Local sales offices are also available to help customers. A listing of sales offices and locations is included in the back of this document.

Technical support is available through the web site at:

<http://www.microchip.com/support>.

## DOCUMENT REVISION HISTORY

### Revision A (August 2014)

- Initial Release of this Document.

# MCP39F501 Power Monitor PICtail™ Evaluation Board User's Guide

---

---

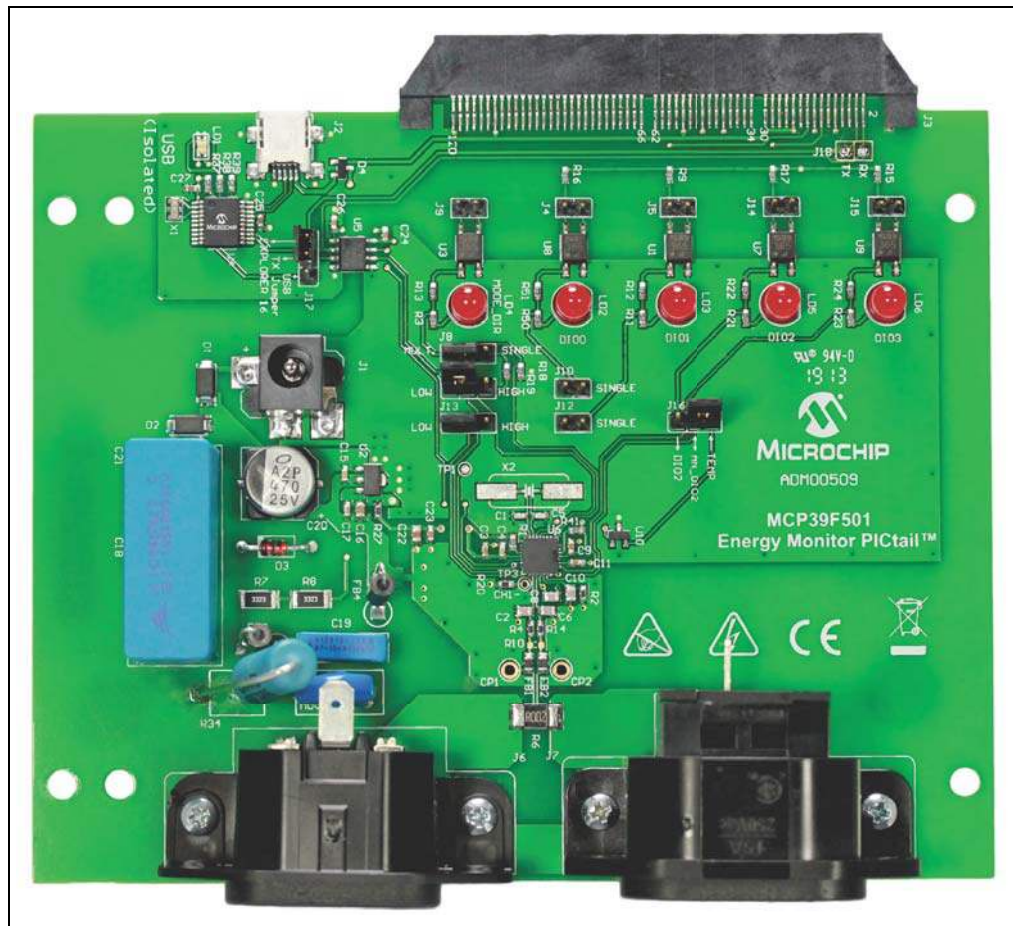
NOTES:

## Chapter 1. Product Overview

### 1.1 INTRODUCTION

The MCP39F501 Power Monitor PICTail™ Evaluation Board provides the option of a fully functional single-phase power monitor, along with a development platform. This low-cost design does not use any transformers and requires few external components. The device calculates active power, reactive power, RMS current, RMS voltage, power factor, line frequency and other typical power quantities as defined in the MCP39F501 data sheet.

The *MCP39F501 Power Monitor Utility* software is used to calibrate and monitor the system, and can be used to create custom calibration setups. For some accuracy requirements, only a single point calibration may be needed.



**FIGURE 1-1:** MCP39F501 Power Monitor PICTail™ Evaluation Board.

## 1.2 WHAT THE MCP39F501 POWER MONITOR PICTAIL™ EVALUATION BOARD KIT INCLUDES

This MCP39F501 Power Monitor PICtail™ Evaluation Board kit includes:

- MCP39F501 Power Monitor PICtail™ Evaluation Board and Case (ADM00509)
- Line Cable
- Load Cable
- USB Cable
- Important Information Sheet

## Chapter 2. Installation and Operation

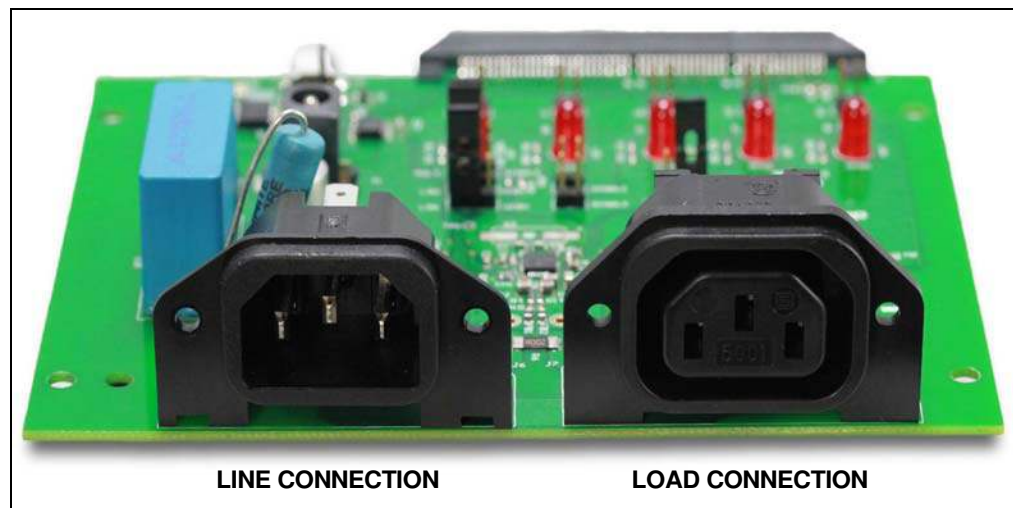
### 2.1 GETTING STARTED

To use the MCP39F501 Power Monitor PICtail™ Evaluation Board, follow the steps described below. The meter design uses a 5A load for nominal current and a maximum current ( $I_{MAX}$ ) of 15A. It is not recommended to draw more than 15A through the AC plugs mounted on the Printed Circuit Board (PCB).

To get started, follow the next steps.

#### 2.1.1 Step 1: Wiring connections

Figure 2-1 identifies the line and load connections of the MCP39F501 Power Monitor PICtail™ Evaluation Board.



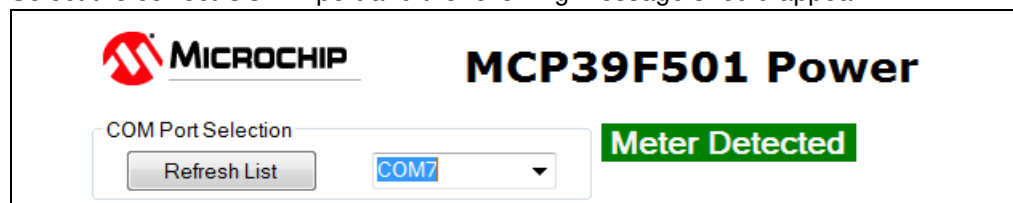
**FIGURE 2-1:** Connecting the MCP39F501 Power Monitor PICtail™ Evaluation Board.

#### 2.1.2 Step 2: Connect the Line Cable to the Meter and plug into appropriate power plug

The meter will turn on when the line connection has between 90V to 230V.

#### 2.1.3 Step 3: Connect the USB cable to a PC with the installed “MCP39F501 Power Monitor Utility” software

Select the correct COMM port and the following message should appear:



**FIGURE 2-2:** Successful Connection Between PC and Evaluation Board.

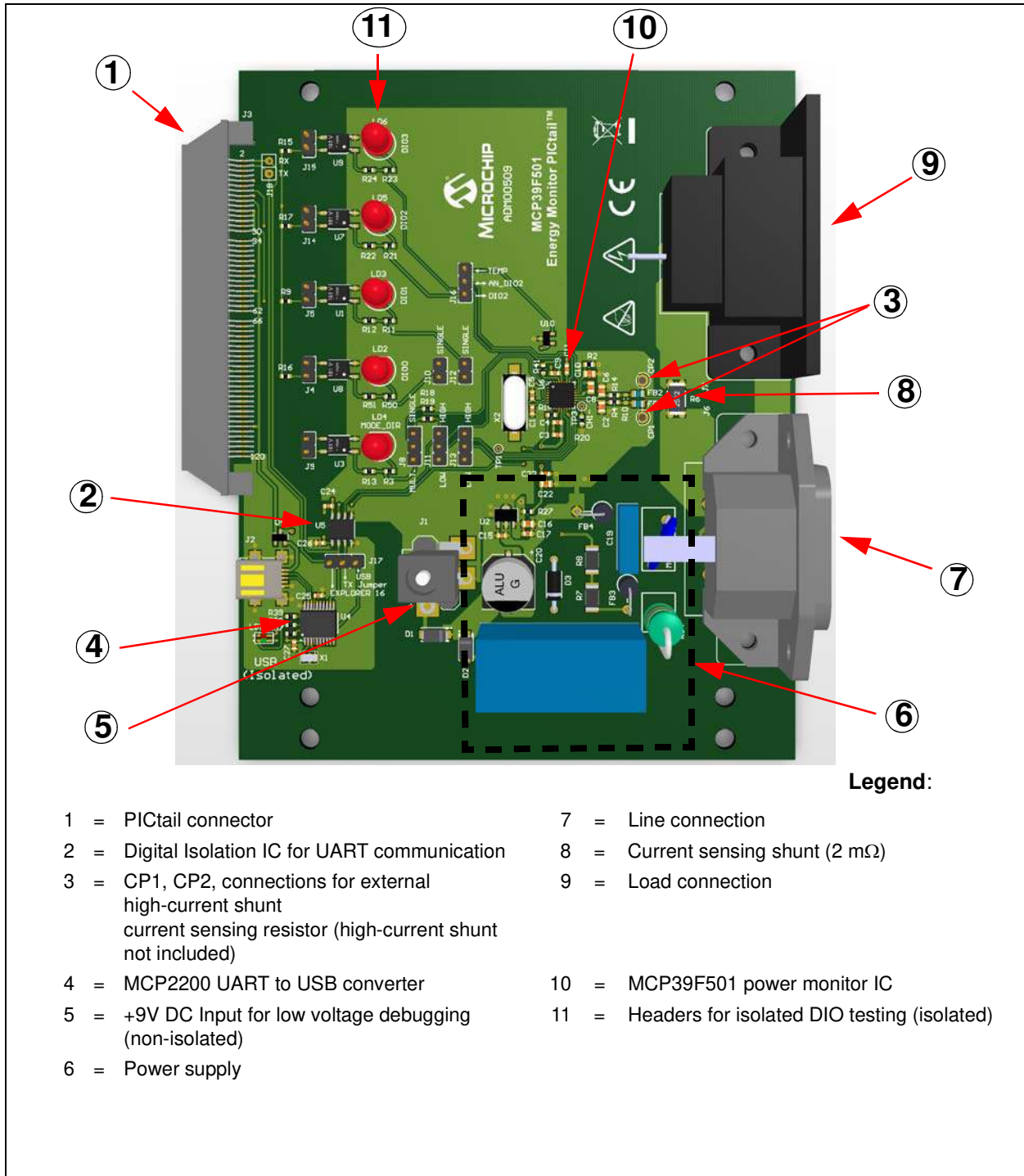
# MCP39F501 Power Monitor PICtail™ Evaluation Board User's Guide

---

---

NOTES:

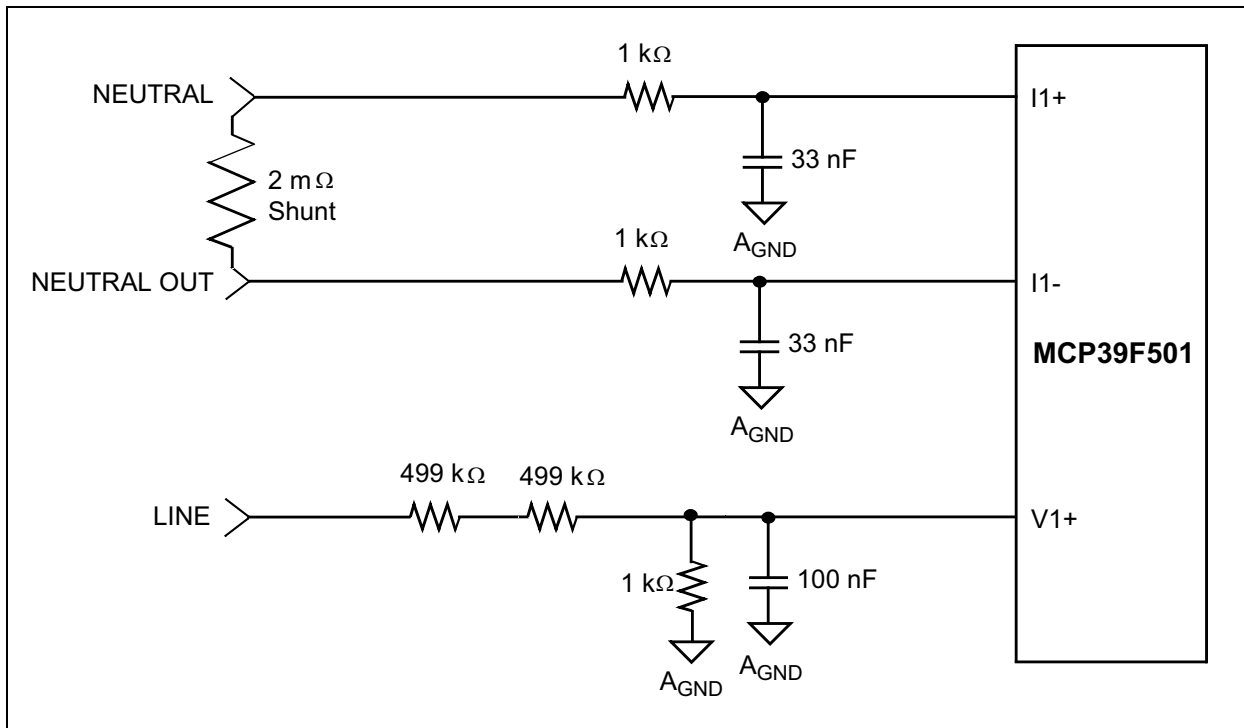
**Chapter 3. Hardware**



**FIGURE 3-1:** Top View – Hardware Components.

## 3.1 INPUT AND ANALOG FRONT END

The MCP39F501 Power Monitor PICtail™ Evaluation Board comes populated with components designed for 90V to 230V line voltage. The neutral side of the phase goes through a 2 mΩ shunt connected directly to the MCP39F501 for current measurement. The line side of the phase goes through a 1000:1 voltage divider and into the device for voltage measurement.



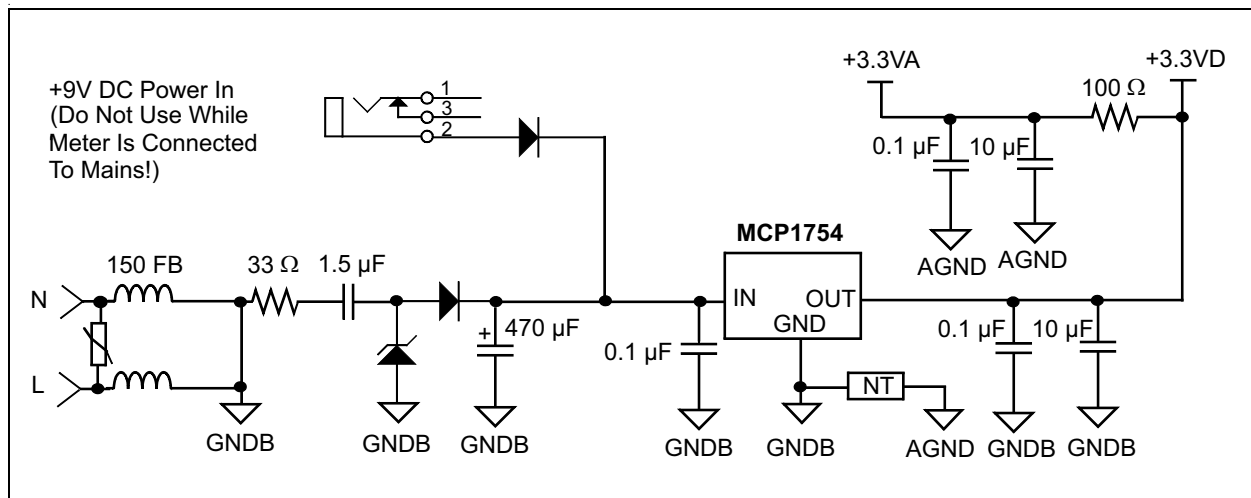
**FIGURE 3-2:** Analog Front End Circuitry.

**Note:** All of the analog circuitry associated with this part of the circuit is connected to the analog ground plane, AGND. Similar grounding and layout approaches should be used in all MCP39F501 applications. For complete schematic and PCB layout information, see [Appendix A. “Schematic and Layouts”](#) and [Appendix B. “Bill of Materials \(BOM\)”](#).



## 3.2 LOW-COST POWER SUPPLY CIRCUIT

The low-cost power supply circuit for the MCP39F501 Power Monitor PICtail™ Evaluation Board uses a capacitively divided half-wave rectified signal, and a +3.3V voltage regulator.



**FIGURE 3-3:** Low-Cost Power Supply Circuit.

# MCP39F501 Power Monitor PICtail™ Evaluation Board User's Guide

---

---

NOTES:

---

---

## Appendix A. Schematic and Layouts

---

---

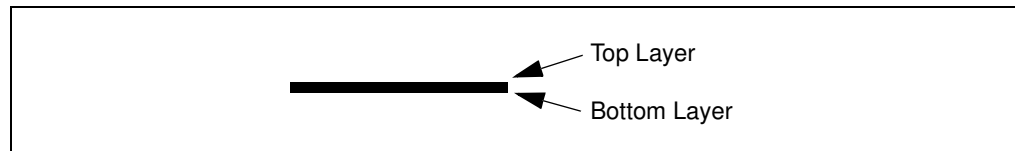
### A.1 INTRODUCTION

This appendix contains the following schematics and layouts for of the MCP39F501 Power Monitor PICtail™ Evaluation Board:

- Board – Schematic 1
- Board – Schematic 2
- Board – Assembly Top
- Board – Top Silk
- Board – Top Copper and Silk
- Board – Top Copper
- Board – Bottom Copper

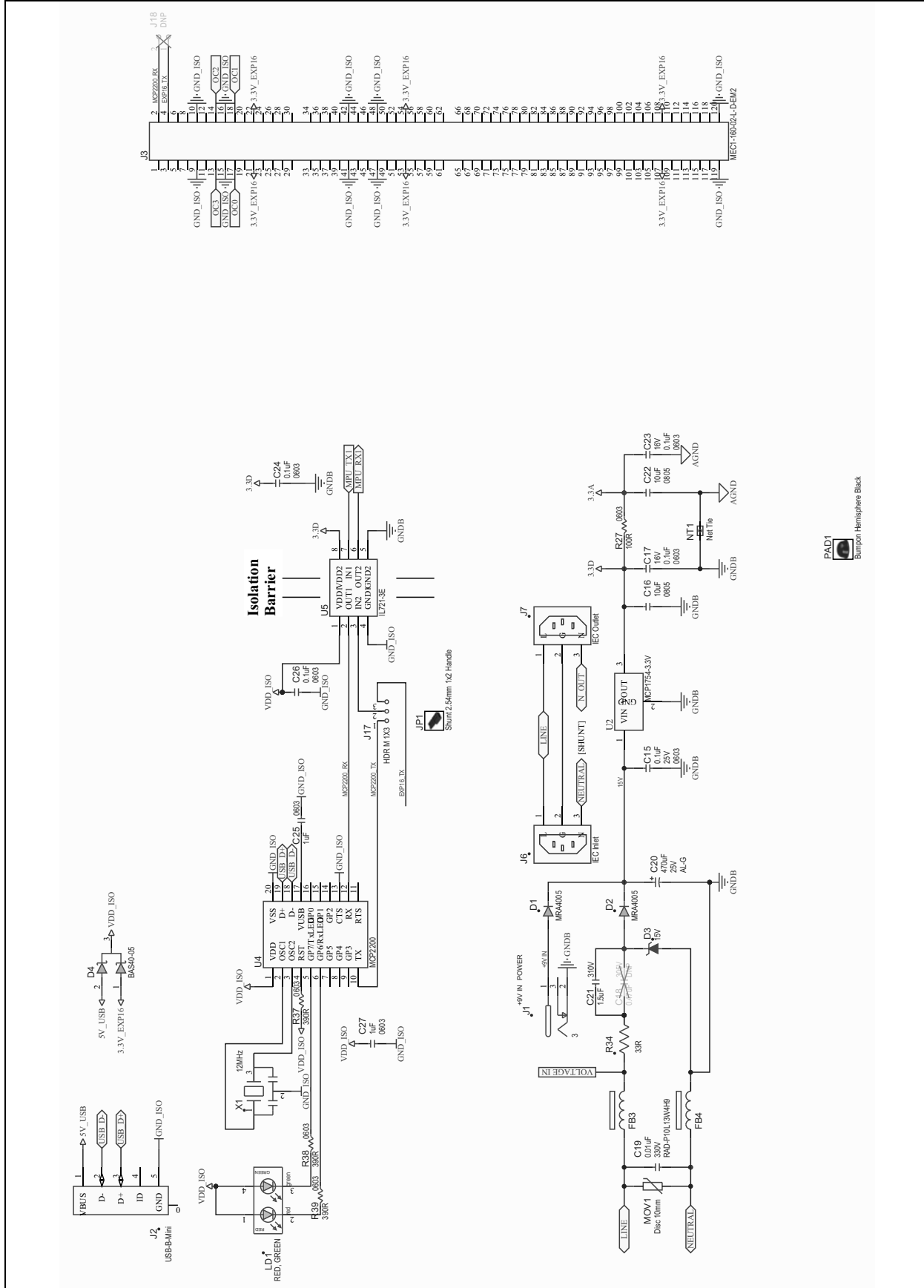
### A.2 SCHEMATICS AND PCB LAYOUT

The layer order is shown in [Figure A-1](#).

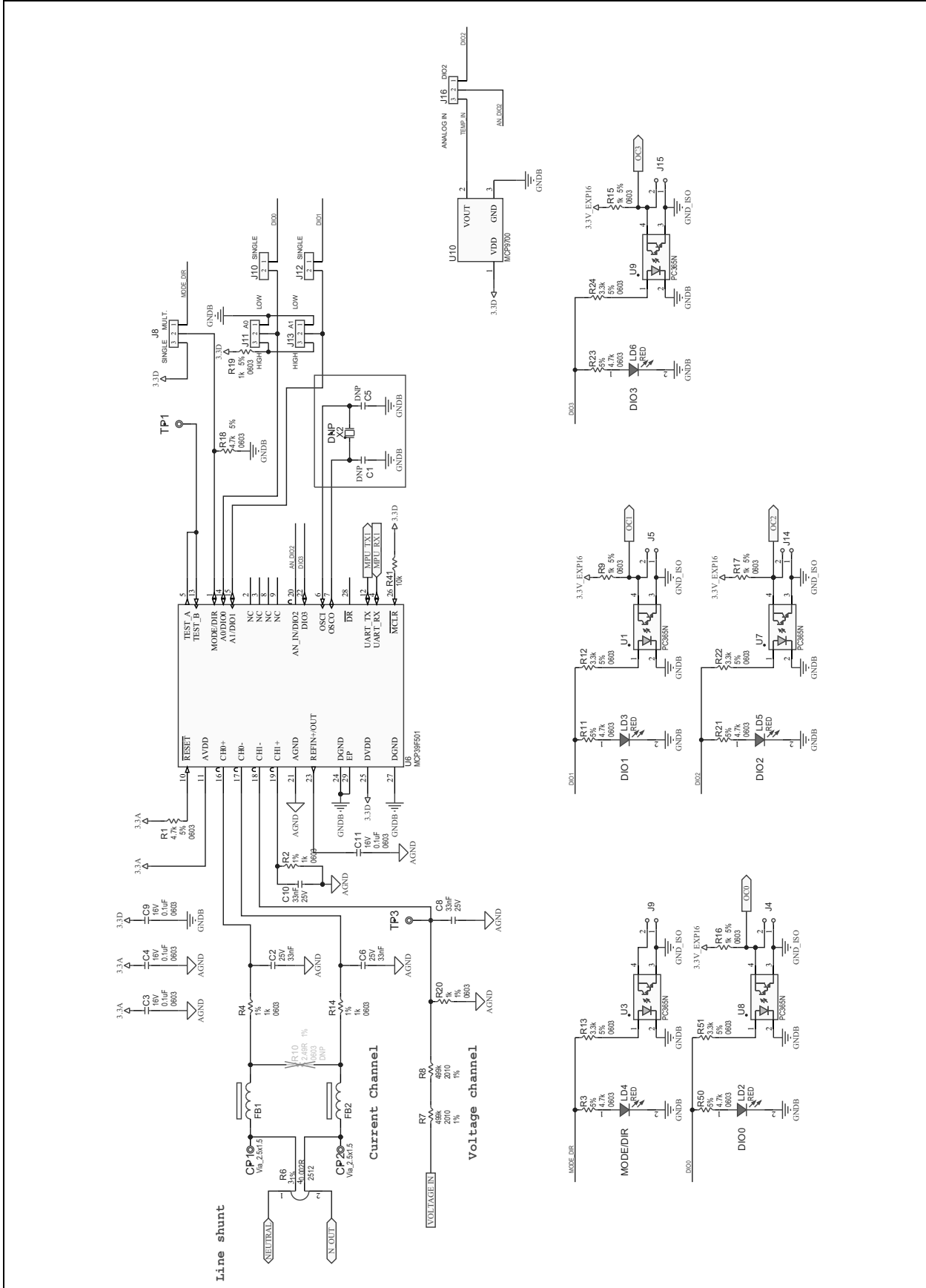


**FIGURE A-1:** Layer Order.

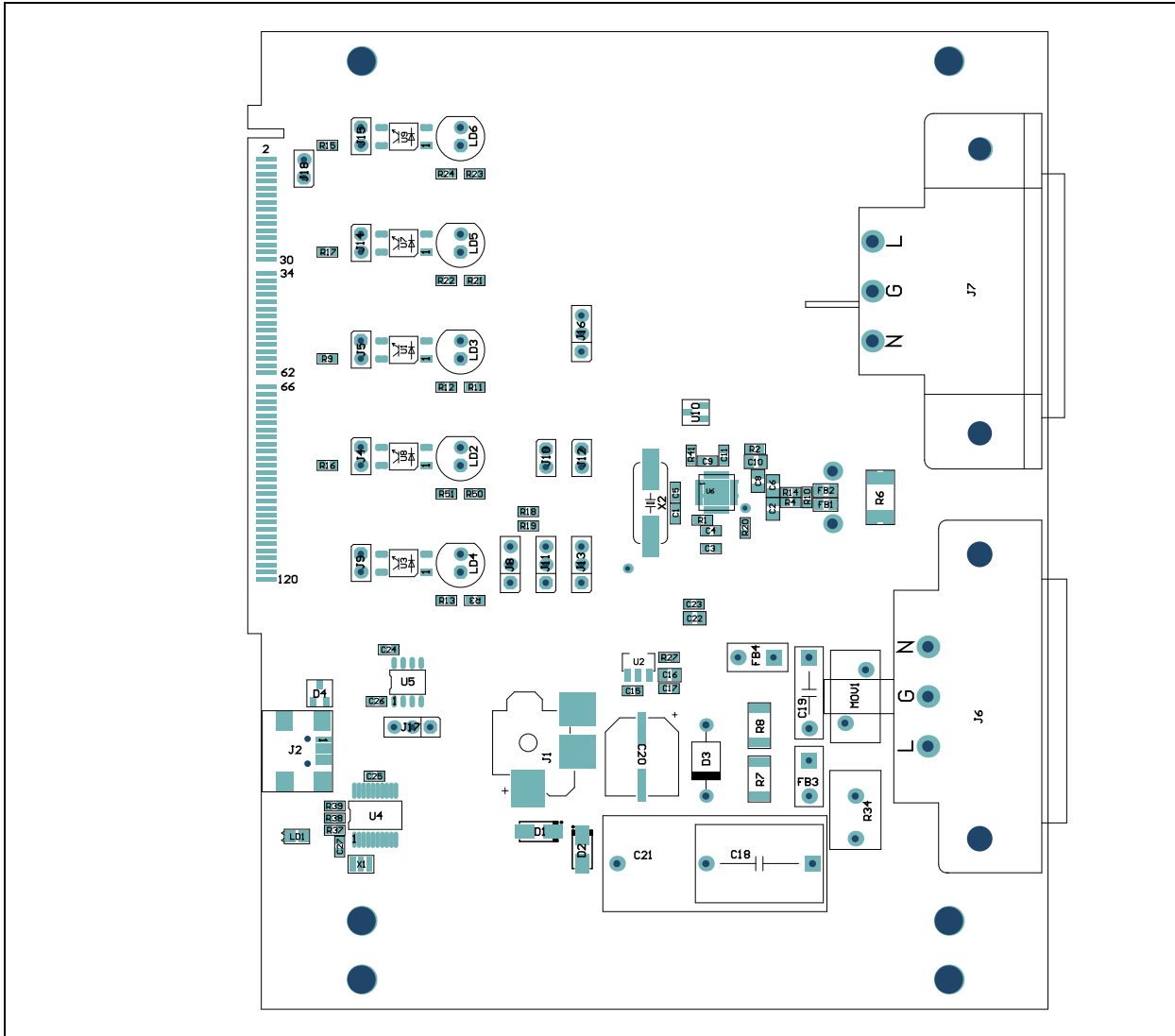
## A.3 BOARD – SCHEMATIC 1



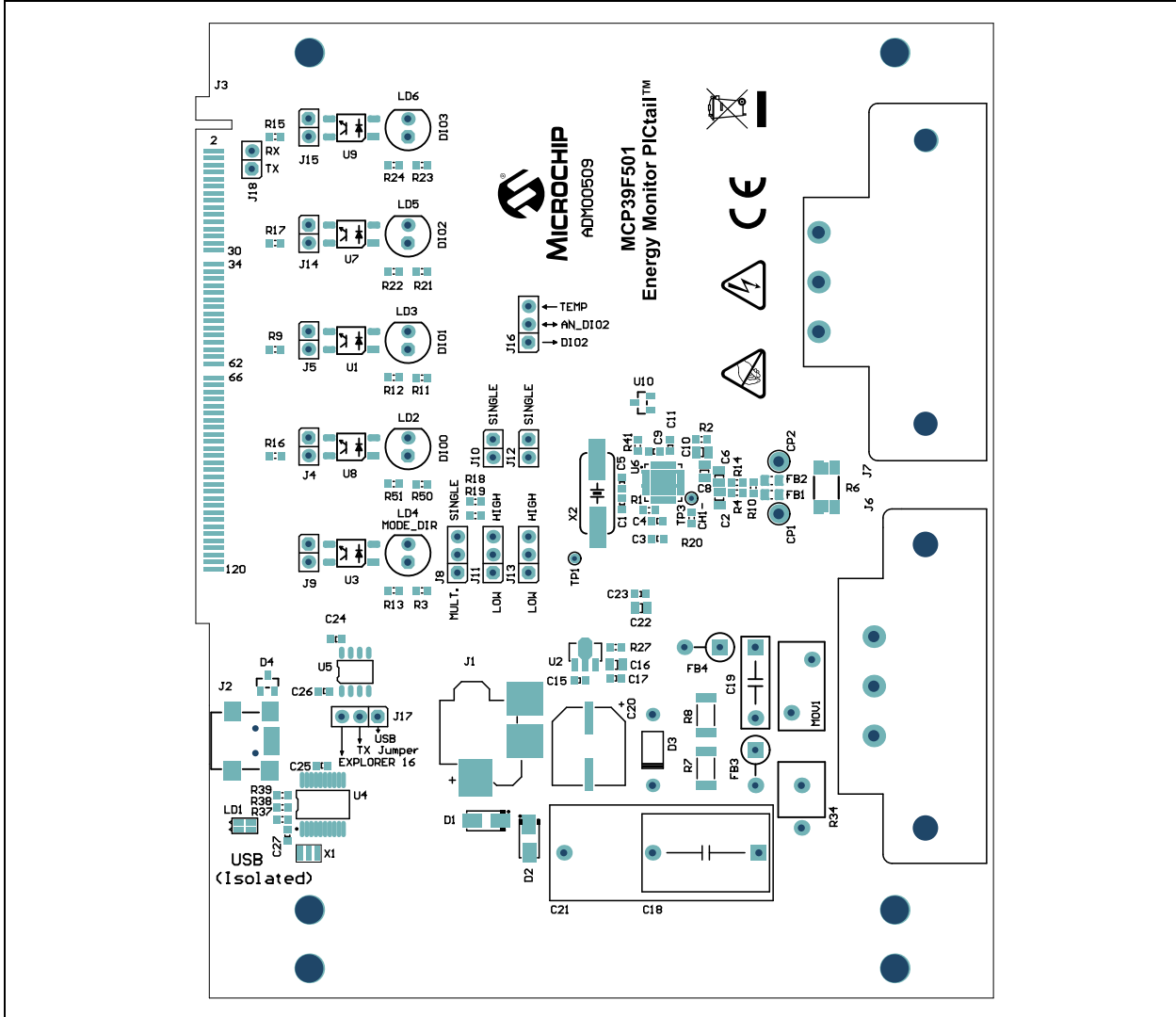
## A.4 BOARD – SCHEMATIC 2



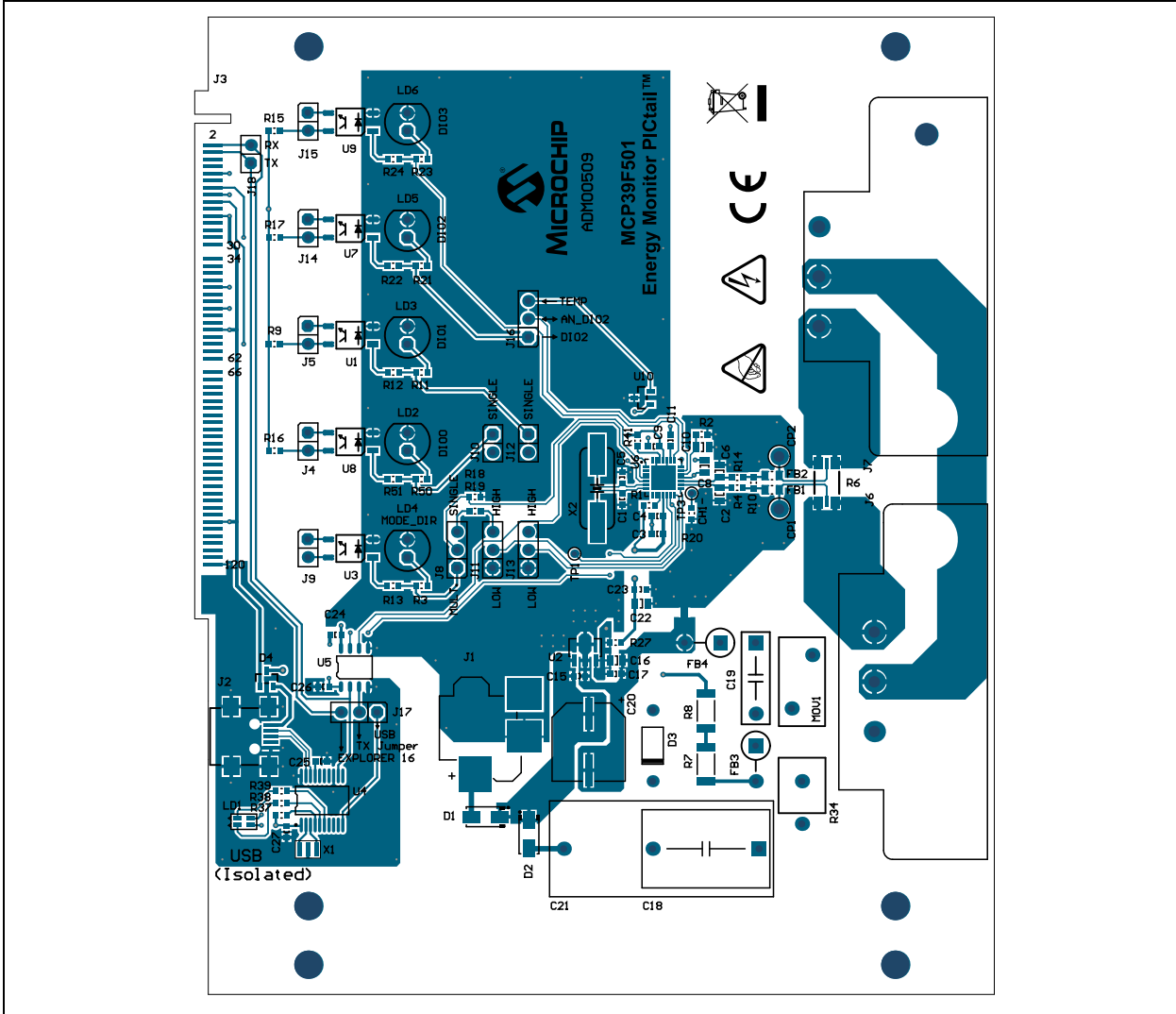
## A.5 BOARD – ASSEMBLY TOP



## A.6 BOARD – TOP SILK

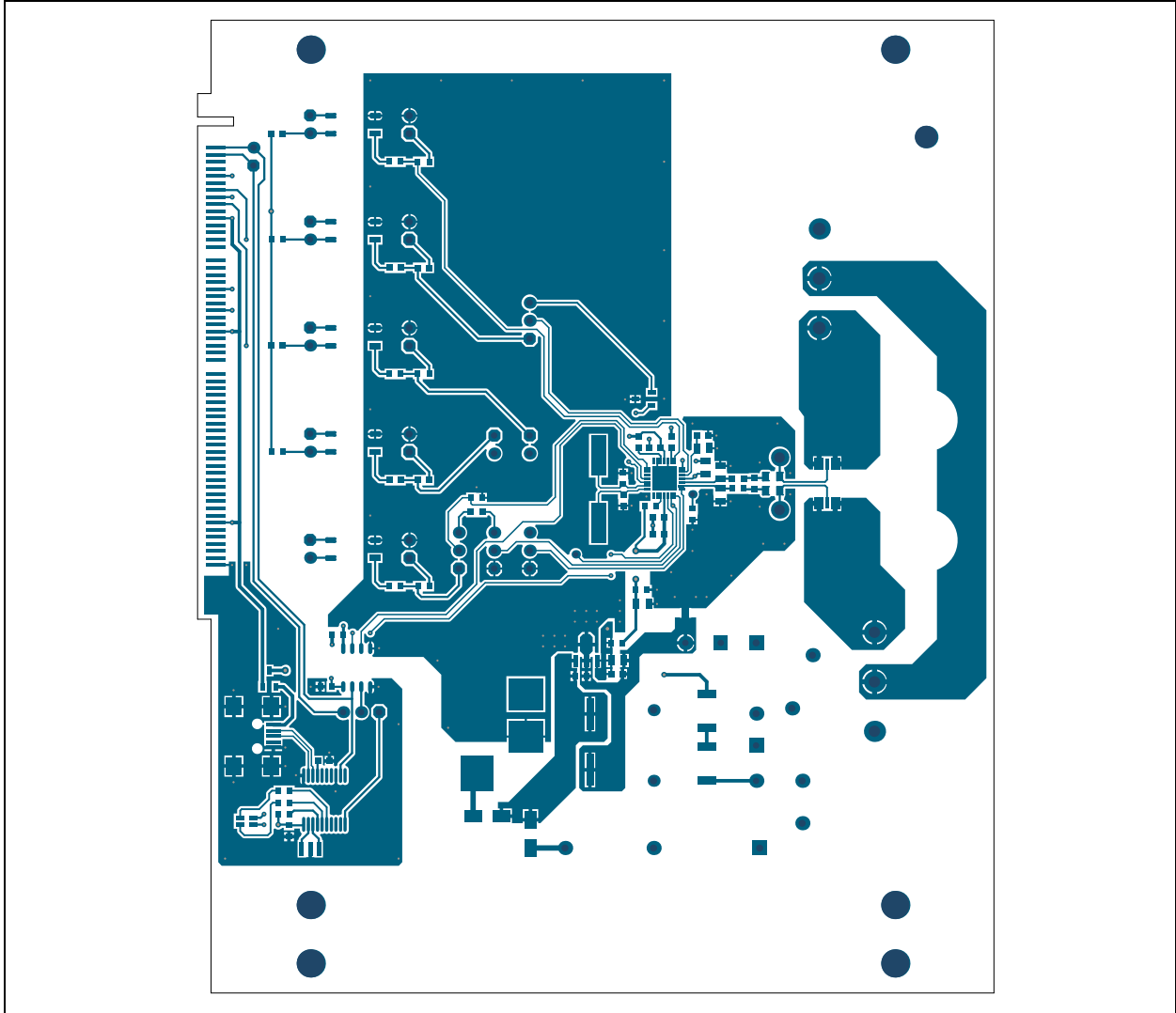


## A.7 BOARD – TOP COPPER AND SILK

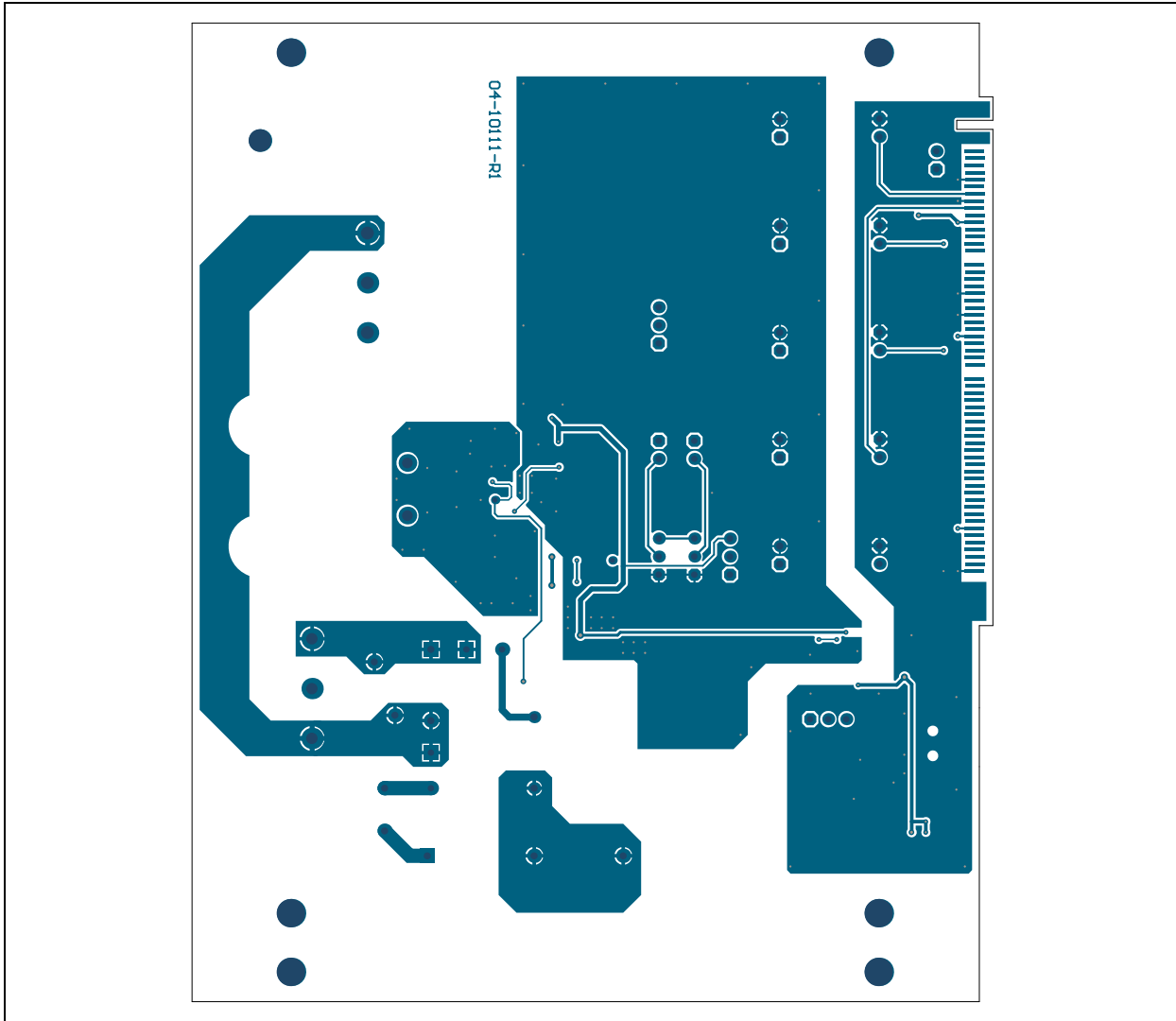




## A.8 BOARD – TOP COPPER



## A.9 BOARD – BOTTOM COPPER



**Appendix B. Bill of Materials (BOM)**

**TABLE B-1: BILL OF MATERIALS (BOM)**

Qty	Reference	Description	Manufacturer	Part Number
2	C1, C5	Cap. ceramic 18 pF 50V 5% NP0 SMD 0603 - <b>DO NOT POPULATE</b>	Panasonic® - ECG	ECJ-1VC1H180J
1	C15	Cap. ceramic 0.1 µF 25V 5% X7R SMD 0603	AVX Corporation	06033C104JAT2A
2	C16, C22	Cap. ceramic 10 µF 10V 20% Y5V SMD 0805	TDK Corporation	C2012Y5V1A106Z
0	C18	Cap. film 0.47 µF 305V 20% RAD P15L18W11H18.5 - <b>DO NOT POPULATE</b>	EPCOS AG	B32932A3474M
1	C19	Cap. film 0.01 µF 330V 20% RAD P10L13W4H9	EPCOS AG	B32911A3103M
4	C2, C6, C8, C10	Cap. ceramic 33 nF 25V 5% C0G, NP0 SMD 0805	TDK Corporation	C2012C0G1E333J
1	C20	Cap. alum. 470 µF 25V 20% SMD G	Nichicon Corporation	UWT1E471MNL1GS
1	C21	Cap. film 1.5 µF 310V 20% RAD P27.5L31.5W13.5H23	EPCOS AG	B32924A2155M
2	C25, C27	Cap. ceramic 1 µF 10V 20% X7R SMD 0603	TDK Corporation	C1608X7R1A105M
8	C3, C4, C9, C11, C17, C23, C24, C26	Cap. ceramic 0.1 µF 16V 10% X7R 0603	TDK Corporation	C1608X7R1C104K
2	D1, D2	Diode rect. MRA4005 1.1V 1A 600V DO-214AC_SMA	ON Semiconductor®	MRA4005T3G
1	D3	Diode zener 1N4744A 15V 1W DO-41	Fairchild Semiconductor®	1N4744A
1	D4	Diode Sctky. Arr. bas. 40-05 1V 200 mA 40V SOT-23-3	Vishay	BAS40-05-V-GS08
4	Fasten J6 & J7 to PCB at four locations	Machine screw pan Phillips 6-32	B&F™ Fasteners Supply	NY PMS 632 0038 PH
4	Fasten J6 & J7 to PCB at four locations	Hex nut 5/16" nylon 6-32	B&F™ Fasteners Supply	NY HN 632
2	FB1, FB2	Ferrite 800 mA 0.15R SMD 0805	Laird Technologies®	LI0805H151R-10
2	FB3, FB4	Ferrite 7A 0.01R RAD P5L5.3D3.8	Panasonic® - ECG	EXC-ELSR35S
1	Included in Box at time of packing	USB a male to mini USB B 5 pin cable - 3 foot (distributor Katerno.com)	Katerno.com	10UM-02103BK
1	Included in Box at time of packing	6 foot 16 AWG universal power cord (IEC320C13 to NEMA 5-15P)	Katerno.com	25545_c2g

**Note 1:** The components listed in this Bill of Materials are representative of the PCB assembly. The released BOM used in manufacturing uses all RoHS-compliant components.

# Bill of Materials (BOM)

**TABLE B-1: BILL OF MATERIALS (BOM) (CONTINUED)**

Qty	Reference	Description	Manufacturer	Part Number
1	Included in Box at time of packing	1 foot 18 AWG monitor power adapter cord (NEMA 5-15R to IEC320C14)	Katerno.com	03147_c2g
1	J1	Conn. jack power jack 2.5 mm	CUI Inc.	PJ-006B-SMT
0	J18	Conn. header-2.54 male 1x2 th. vert. - <b>DO NOT POPULATE</b>	FCI	77311-118-02LF
1	J2	Conn. USB mini USB-B female SMD R/A	Hirose Electric Co., Ltd.	UX60-MB-5ST
1	J3	Conn. edge mini edge card MEC1-EM 1mm female 2x60 SMD R/A	Samtec, Inc.	MEC1-160-02-L-D-EM2
7	J4, J5, J9, J10, J12, J14, J15	Conn. header-2.54 male 1x2 th. vert.	FCI	77311-118-02LF
1	J6	Conn. IEC 250V 15A Inlet th. R/A	SCHURTER Inc.	GSP1.9103.1
1	J7	Conn. IEC 250V 15A Outlet th. R/A	SCHURTER Inc.	6182.0033
5	J8, J11, J13, J16, J17	Conn. header-2.54 male 1x3 th. vert.	FCI	68000-103HLF
1	JP1	Mech. hw. jumper 2.54 mm 1x2 handle gold	TE Connectivity, Ltd.	881545-2
1	LD1	Diode LED bi. red, green 1.95V, 2.1V 30 mA 0805	Kingbright Corp.	APHBM2012SURKCGKC
5	LD2, LD3, LD4, LD5, LD6	Diode LED red 1.65V 30 mA RAD T-1_3/4	Kingbright Corp.	WP7113LSRD
1	Meter Enclosure	Clear acrylic enclosure	Tech-Demos.com	072612 R6
1	MOV1	Resistor varistor mo. 420V 45J disc 10 mm	EPCOS AG	S10K420
4	PAD1	Mech. hw. rubber pad Bumpon Hemisphere 0.44" x 0.20" Black	3M	SJ-5003 (BLACK)
7	R1, R3, R11, R18, R21, R23, R50	Resistor tkf. 4.7k 5% 1/10W SMD 0603	Panasonic - ECG	ERJ-3GEYJ472V
0	R10	Resistor tkf. 2.49R 1% 1/10W SMD 0603 - <b>DO NOT POPULATE</b>	Vishay	CRCW06032R49FKEA
5	R12, R13, R22, R24, R51	Resistor tkf. 3.3k 5% 1/10W SMD 0603	Panasonic - ECG	ERJ-3GEYJ332V
4	R2, R4, R14, R20	Resistor tkf. 1k 1% 1/10W SMD 0603	Panasonic - ECG	ERJ-3EKF1001V
1	R27	Res. tkf. 100R 1% 1/10W SMD 0603	Panasonic - ECG	ERJ-3EKF1000V
1	R34	Res. 33 ohm 5W 1% AXIAL	Ohmite <sup>®</sup> Manufacturing	45F33RE
3	R37, R38, R39	Res. tkf. 390R 5% 1/10W SMD 0603	Panasonic - ECG	ERJ-3GEYJ391V
1	R41	Res. tkf. 10k 5% 1/10W SMD 0603	Panasonic - ECG	ERJ-3GEYJ103V
1	R6	Res. shunt MF 0.002R 1% 2W 2512	Stackpole Electronics, Inc.	CSNL2512FT2L00
2	R7, R8	Res. 499K ohm 3/4W 1% 2010 SMD	Vishay Dale	CRCW2010499KFKEF
5	R9, R15, R16, R17, R19	Resistor tkf. 1k 5% 1/10W SMD 0603	Panasonic - ECG	ERJ-3GEYJ102V
5	U1, U3, U7, U8, U9	IC photo PC365N 4-SMD	Sharp Microelectronics	PC365NJ0000F

**Note 1:** The components listed in this Bill of Materials are representative of the PCB assembly. The released BOM used in manufacturing uses all RoHS-compliant components.

# Bill of Materials (BOM)

**TABLE B-1: BILL OF MATERIALS (BOM) (CONTINUED)**

Qty	Reference	Description	Manufacturer	Part Number
1	U10	Microchip Analog Temperature Sensor MCP9700 SOT-23-3	Microchip Technology Inc.	<b>MCP9700T-E/TT</b>
1	U2	Microchip Analog LDO MCP1754ST-3302E/MB SOT-89-3	Microchip Technology Inc.	<b>MCP1754ST-3302E/MB</b>
1	U4	Microchip int. USB MCP2200 SSOP-20	Microchip Technology Inc.	<b>MCP2200-I/SS</b>
1	U5	IC isolator IL721-3E SOIC-8	NVE Corp./Isolation Products	IL721-3E
1	U6	MCP39F501 QFN-28	Microchip Technology Inc.	<b>MCP39F501-E/MQ</b>
1	X1	Resonator 12MHz 0.1% SMD CSTCE-G	Murata Manufacturing Co., Ltd.	CSTCE12M0G15L99-R0
1	X2	Crystal 4MHz 18pF SMD HC49/US - <b>DO NOT POPULATE</b>	Abracon <sup>®</sup> Corporation	ABLS-4.000MHZ-B4-T

**Note 1:** The components listed in this Bill of Materials are representative of the PCB assembly. The released BOM used in manufacturing uses all RoHS-compliant components.



# MICROCHIP

## Worldwide Sales and Service

### AMERICAS

**Corporate Office**  
2355 West Chandler Blvd.  
Chandler, AZ 85224-6199  
Tel: 480-792-7200  
Fax: 480-792-7277  
Technical Support:  
<http://www.microchip.com/support>  
Web Address:  
[www.microchip.com](http://www.microchip.com)

**Atlanta**  
Duluth, GA  
Tel: 678-957-9614  
Fax: 678-957-1455

**Austin, TX**  
Tel: 512-257-3370

**Boston**  
Westborough, MA  
Tel: 774-760-0087  
Fax: 774-760-0088

**Chicago**  
Itasca, IL  
Tel: 630-285-0071  
Fax: 630-285-0075

**Cleveland**  
Independence, OH  
Tel: 216-447-0464  
Fax: 216-447-0643

**Dallas**  
Addison, TX  
Tel: 972-818-7423  
Fax: 972-818-2924

**Detroit**  
Novi, MI  
Tel: 248-848-4000

**Houston, TX**  
Tel: 281-894-5983

**Indianapolis**  
Noblesville, IN  
Tel: 317-773-8323  
Fax: 317-773-5453

**Los Angeles**  
Mission Viejo, CA  
Tel: 949-462-9523  
Fax: 949-462-9608

**New York, NY**  
Tel: 631-435-6000

**San Jose, CA**  
Tel: 408-735-9110

**Canada - Toronto**  
Tel: 905-673-0699  
Fax: 905-673-6509

### ASIA/PACIFIC

**Asia Pacific Office**  
Suites 3707-14, 37th Floor  
Tower 6, The Gateway  
Harbour City, Kowloon  
Hong Kong  
Tel: 852-2943-5100  
Fax: 852-2401-3431

**Australia - Sydney**  
Tel: 61-2-9868-6733  
Fax: 61-2-9868-6755

**China - Beijing**  
Tel: 86-10-8569-7000  
Fax: 86-10-8528-2104

**China - Chengdu**  
Tel: 86-28-8665-5511  
Fax: 86-28-8665-7889

**China - Chongqing**  
Tel: 86-23-8980-9588  
Fax: 86-23-8980-9500

**China - Hangzhou**  
Tel: 86-571-8792-8115  
Fax: 86-571-8792-8116

**China - Hong Kong SAR**  
Tel: 852-2943-5100  
Fax: 852-2401-3431

**China - Nanjing**  
Tel: 86-25-8473-2460  
Fax: 86-25-8473-2470

**China - Qingdao**  
Tel: 86-532-8502-7355  
Fax: 86-532-8502-7205

**China - Shanghai**  
Tel: 86-21-5407-5533  
Fax: 86-21-5407-5066

**China - Shenyang**  
Tel: 86-24-2334-2829  
Fax: 86-24-2334-2393

**China - Shenzhen**  
Tel: 86-755-8864-2200  
Fax: 86-755-8203-1760

**China - Wuhan**  
Tel: 86-27-5980-5300  
Fax: 86-27-5980-5118

**China - Xian**  
Tel: 86-29-8833-7252  
Fax: 86-29-8833-7256

**China - Xiamen**  
Tel: 86-592-2388138  
Fax: 86-592-2388130

**China - Zhuhai**  
Tel: 86-756-3210040  
Fax: 86-756-3210049

### ASIA/PACIFIC

**India - Bangalore**  
Tel: 91-80-3090-4444  
Fax: 91-80-3090-4123

**India - New Delhi**  
Tel: 91-11-4160-8631  
Fax: 91-11-4160-8632

**India - Pune**  
Tel: 91-20-3019-1500

**Japan - Osaka**  
Tel: 81-6-6152-7160  
Fax: 81-6-6152-9310

**Japan - Tokyo**  
Tel: 81-3-6880-3770  
Fax: 81-3-6880-3771

**Korea - Daegu**  
Tel: 82-53-744-4301  
Fax: 82-53-744-4302

**Korea - Seoul**  
Tel: 82-2-554-7200  
Fax: 82-2-558-5932 or  
82-2-558-5934

**Malaysia - Kuala Lumpur**  
Tel: 60-3-6201-9857  
Fax: 60-3-6201-9859

**Malaysia - Penang**  
Tel: 60-4-227-8870  
Fax: 60-4-227-4068

**Philippines - Manila**  
Tel: 63-2-634-9065  
Fax: 63-2-634-9069

**Singapore**  
Tel: 65-6334-8870  
Fax: 65-6334-8850

**Taiwan - Hsin Chu**  
Tel: 886-3-5778-366  
Fax: 886-3-5770-955

**Taiwan - Kaohsiung**  
Tel: 886-7-213-7830

**Taiwan - Taipei**  
Tel: 886-2-2508-8600  
Fax: 886-2-2508-0102

**Thailand - Bangkok**  
Tel: 66-2-694-1351  
Fax: 66-2-694-1350

### EUROPE

**Austria - Wels**  
Tel: 43-7242-2244-39  
Fax: 43-7242-2244-393

**Denmark - Copenhagen**  
Tel: 45-4450-2828  
Fax: 45-4485-2829

**France - Paris**  
Tel: 33-1-69-53-63-20  
Fax: 33-1-69-30-90-79

**Germany - Dusseldorf**  
Tel: 49-2129-3766400

**Germany - Munich**  
Tel: 49-89-627-144-0  
Fax: 49-89-627-144-44

**Germany - Pforzheim**  
Tel: 49-7231-424750

**Italy - Milan**  
Tel: 39-0331-742611  
Fax: 39-0331-466781

**Italy - Venice**  
Tel: 39-049-7625286

**Netherlands - Drunen**  
Tel: 31-416-690399  
Fax: 31-416-690340

**Poland - Warsaw**  
Tel: 48-22-3325737

**Spain - Madrid**  
Tel: 34-91-708-08-90  
Fax: 34-91-708-08-91

**Sweden - Stockholm**  
Tel: 46-8-5090-4654

**UK - Wokingham**  
Tel: 44-118-921-5800  
Fax: 44-118-921-5820

03/25/14