

SQUARE FLANGE JACK RECEPTACLE
WITH SOLDER POT CONTACT

R161.410.130

Series : N

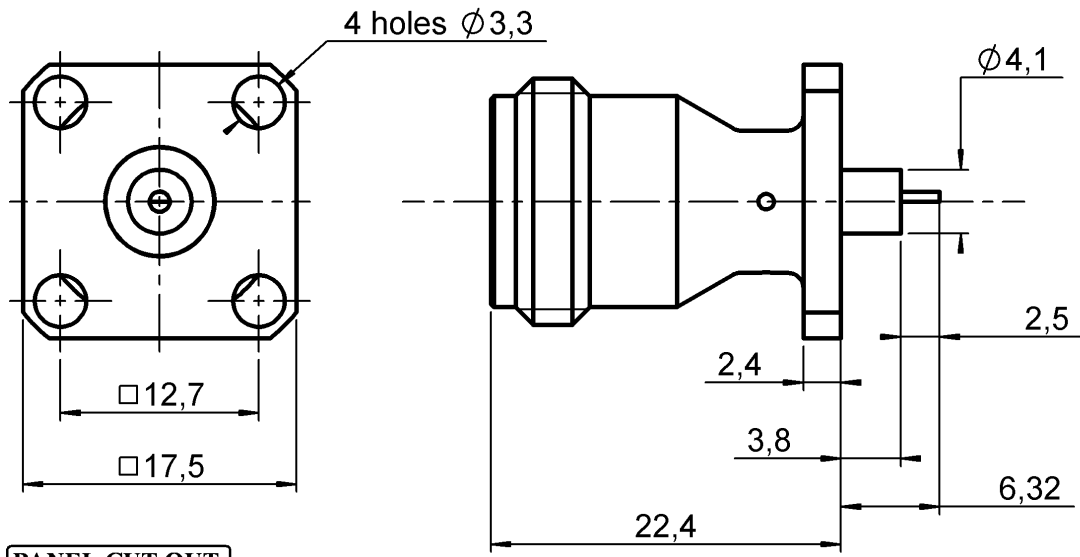

PANEL CUT OUT

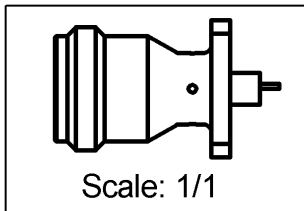
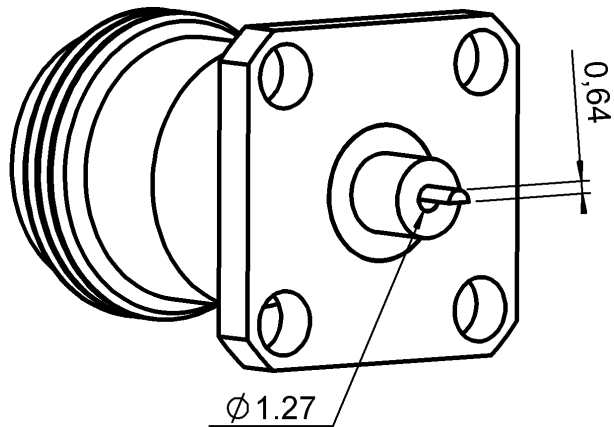
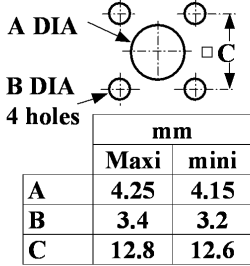

All dimensions are in mm.



COMPONENTS	MATERIALS	PLATING (µm)
BODY	BRASS	NICKEL 2
CENTER CONTACT	BERYLLIUM COPPER	GOLD 0.5 OVER NICKEL 2
OUTER CONTACT	BRASS	-
INSULATOR	PTFE	-
GASKET	-	-
OTHERS PARTS	-	-
-	-	-
-	-	-

Issue : 0617 B

In the effort to improve our products, we reserve the right to make changes judged to be necessary.



**SQUARE FLANGE JACK RECEPTACLE
WITH SOLDER POT CONTACT**

R161.410.130

Series : N

PACKAGING

SPECIFICATION

Standard	Unit	Other
1		Contact us

ELECTRICAL CHARACTERISTICS

ENVIRONMENTAL

Impedance	50	Ω
Frequency	0-11	GHz
VSWR	1.2* + 0,0000	x F(GHz) Maxi
Insertion loss	0.048	\sqrt{F} (GHz) dB Maxi
RF leakage	- (NA)	- F(GHz)) dB Maxi
Voltage rating	1400	Veff Maxi
Dielectric withstanding voltage	2500	Veff mini
Insulation resistance	5000	M Ω mini

Operating temperature	-55/+155	$^{\circ}$ C
Hermetic seal	NA	Atm.cm3/s
Panel leakage	NA	

OTHER CHARACTERISTICS

Assembly instruction **NA**

Others :

* Coaxial Transmission Line Only

MECHANICAL CHARACTERISTICS

Center contact retention		
Axial force – Mating end	27	N mini
Axial force – Opposite end	27	N mini
Torque	2.8	N.cm mini
Recommended torque		
Mating	NA	N.cm
Panel nut	NA	N.cm
Mating life	500	Cycles mini
Weight	19,6309	g

Issue : 0617 B

In the effort to improve our products, we reserve the right to make changes judged to be necessary.

