

REV.	DATE	ECR NO.	DESCRIPTION
NC	04/20/09	XXXXXX	INITIAL RELEASE

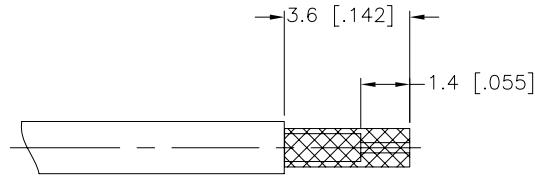

RECOMMENDED
CABLE STRIPPING DIM'S

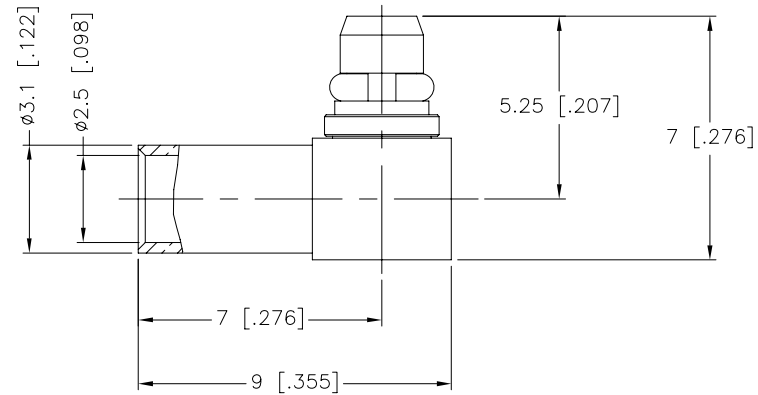
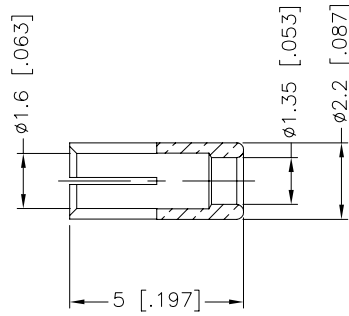
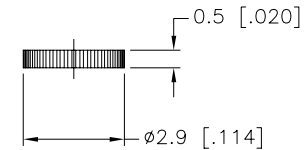
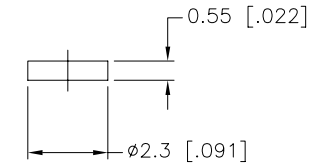

NOTE:
1. CRIMPED FERRULE
HEX CRIMP SIZE .105"
2. CONTACT PIN TO SOLDER

7	COVER	BRASS	GOLD	1
6	INSULATOR	PTFE	NATURAL	1
5	INNER FERRULE	BRASS	GOLD	1
4	RETAINER RING	BER. COPPER	GOLD	1
3	CONTACT PIN	BRASS	GOLD	1
2	INSULATOR	PTFE	NATURAL	1
1	BODY WITH HOUSING	BRASS	GOLD	1
DESCRIPTION	MATERIAL	FINISH	QTY	

UNLESS OTHERWISE SPECIFIED DIMENSIONS ARE IN MILLIMETERS. DIMENSIONS IN [] ARE IN INCHES AND FOR CUSTOMER REFERENCE ONLY.

UNLESS OTHERWISE SPECIFIED TOLERANCES FOR MILLIMETERS ARE:
0.5 - 8mm ± 0.20mm
8 - 30mm ± 0.40mm
30 - 120mm ± 0.50mm

UNLESS OTHERWISE SPECIFIED TOLERANCES FOR INCHES ARE:
.020 - .315 = ± 0.007"
.315 - 1.180 = ± 0.015"
1.180 - 4.724 = ± 0.020"

DO NOT SCALE DRAWING

APPROVALS	DATE
DRAWN M.ZHANG	04/20/09
CHECKED	
ISSUED	
SHEET 1 OF 1	
CAD FILE	C:/CONNEX/262147.DWG

<h1>Amphenol Connex</h1>			
PART DESCRIPTION			
MMCX R/A CRIMP PLUG (FOR 1.37mm CABLE)			
PART NO.			
262147			
DWG. NO.	262147.DWG	REV.	NC
SIZE	A	SCALE	NA