

2 kW 3-phase motor control evaluation board featuring the STGIPS20C60 IGBT intelligent power module

Data brief

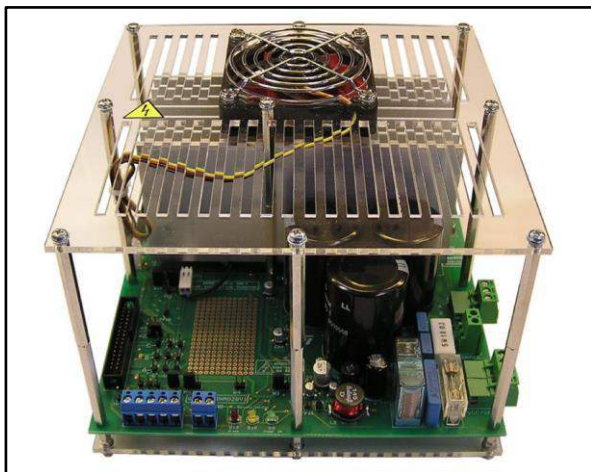

Description

The goal of the STEVAL-IHM028V2 product evaluation board is to present a universal, fully tested and populated design consisting of a 3-phase inverter bridge based on the 600 V, 17 A intelligent power module STGIPS20C60. The IPM itself consists of short-circuit rugged IGBTs with negative temperature co-efficiency. It also contains a wide range of auxiliary functions like undervoltage lockout and smart shutdown.

Thanks to these advanced characteristics, the system has been specifically designed to achieve accurate and fast conditioning of the current feedback, matching the typical requirements for field oriented control (FOC).

This board can be used to evaluate a wide range of applications such as HVAC (air conditioners), power white goods and high-end single-phase power tools.

Features

- Complete solution for a 2 kW power inverter
- HV supply mode: voltage 90 VAC to 285 VAC or direct DC line 125 V DC to 400 V DC
- Input voltage range extended to +400 V, for PFC compliance
- Input inrush limiter with bypassing relay
- Brake feature with overvoltage comparator
- Single- or three-shunt resistor current sensing method
- Hall sensor or encoder input
- Tachometer input
- Overtemperature and overcurrent hardware protection
- Active fan with automatic overtemperature switching
- Compact and safe design
- Universal conception for further evaluation with bread board and testing pins
- RoHS compliant

1 Schematic diagrams

Figure 1: STEVAL-IHM028V2 circuit schematic (1 of 6)

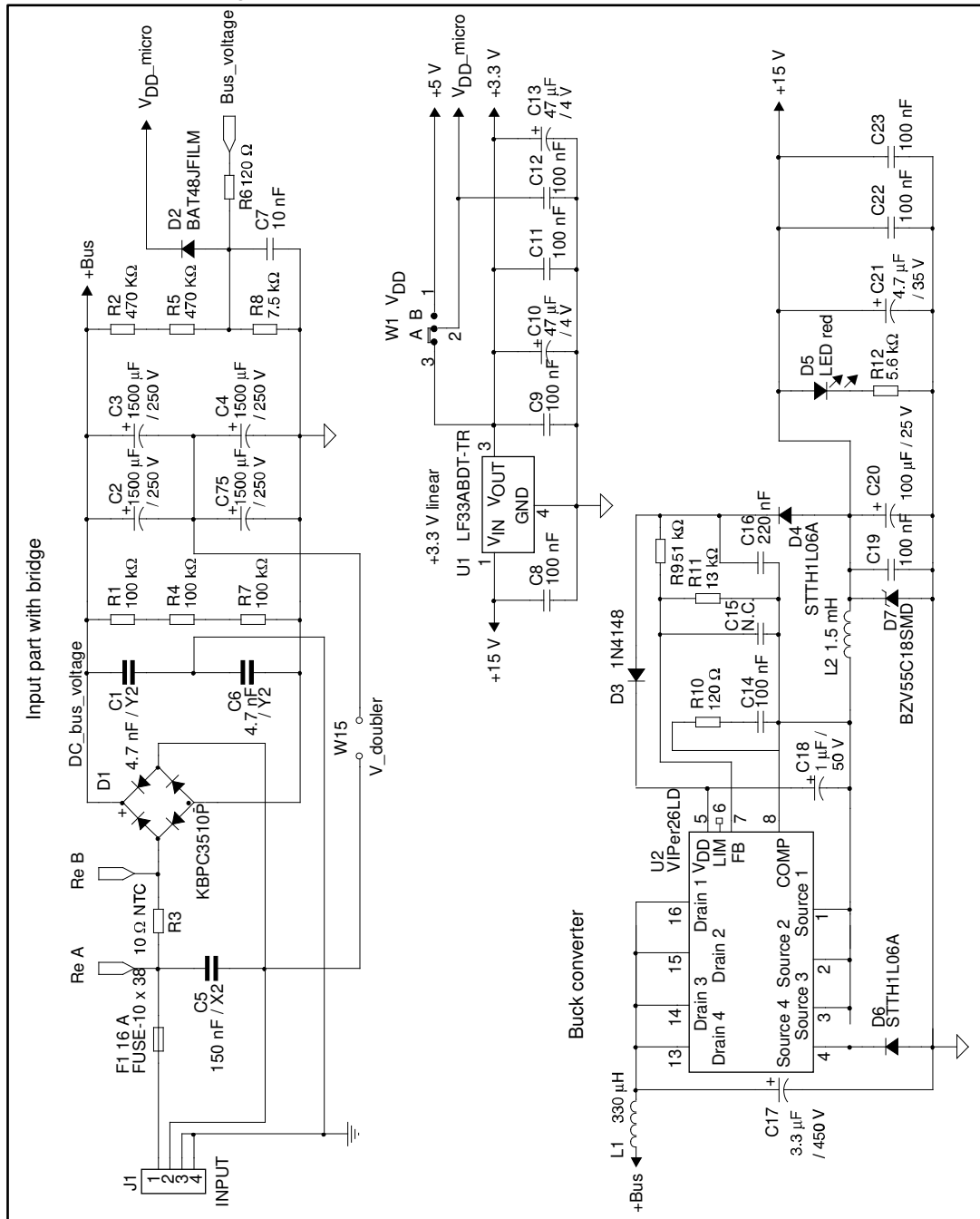

Figure 2: STEVAL-IHM028V2 circuit schematic (2 of 6)

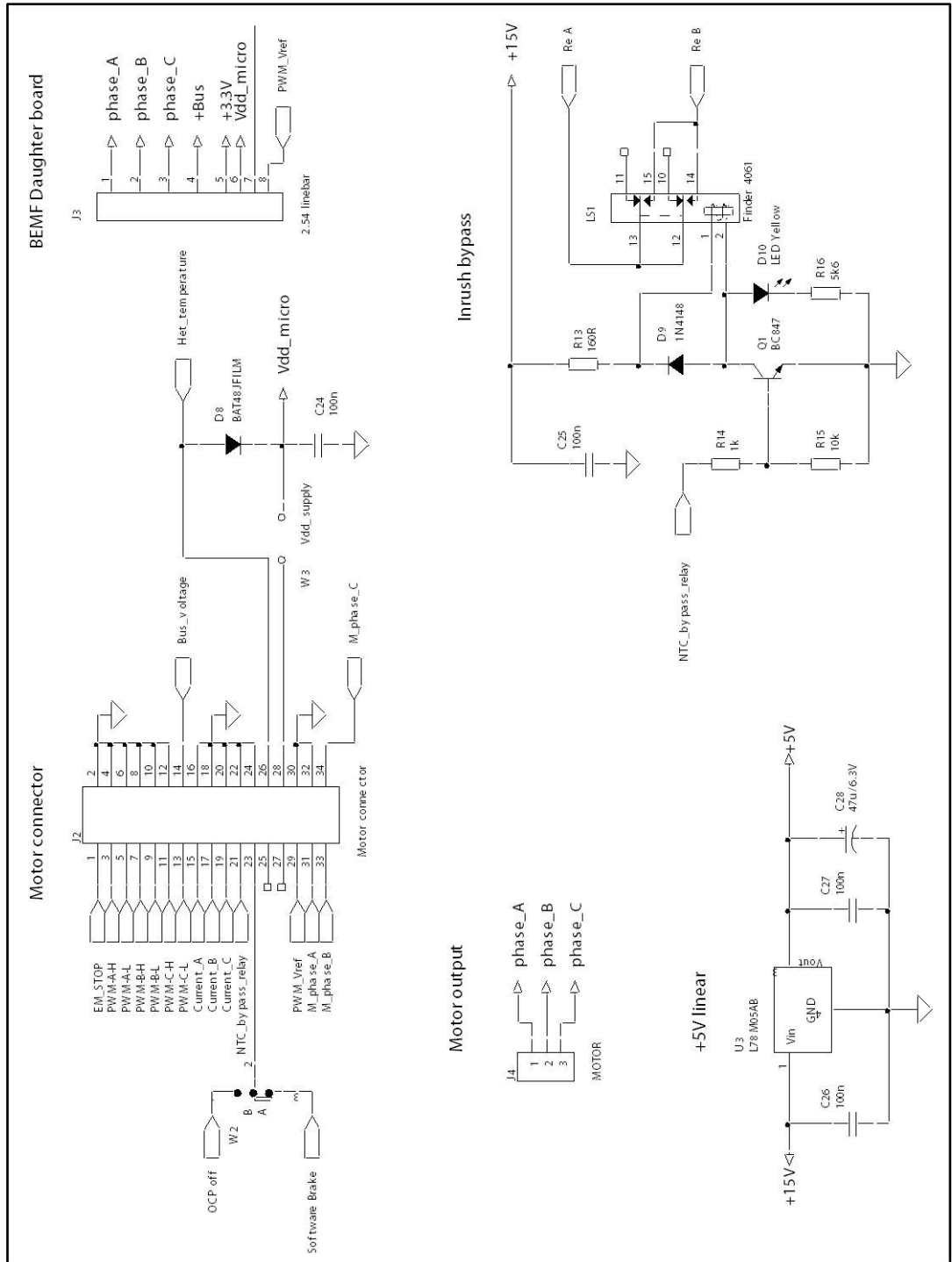

Figure 3: STEVAL-IHM028V2 circuit schematic (3 of 6)

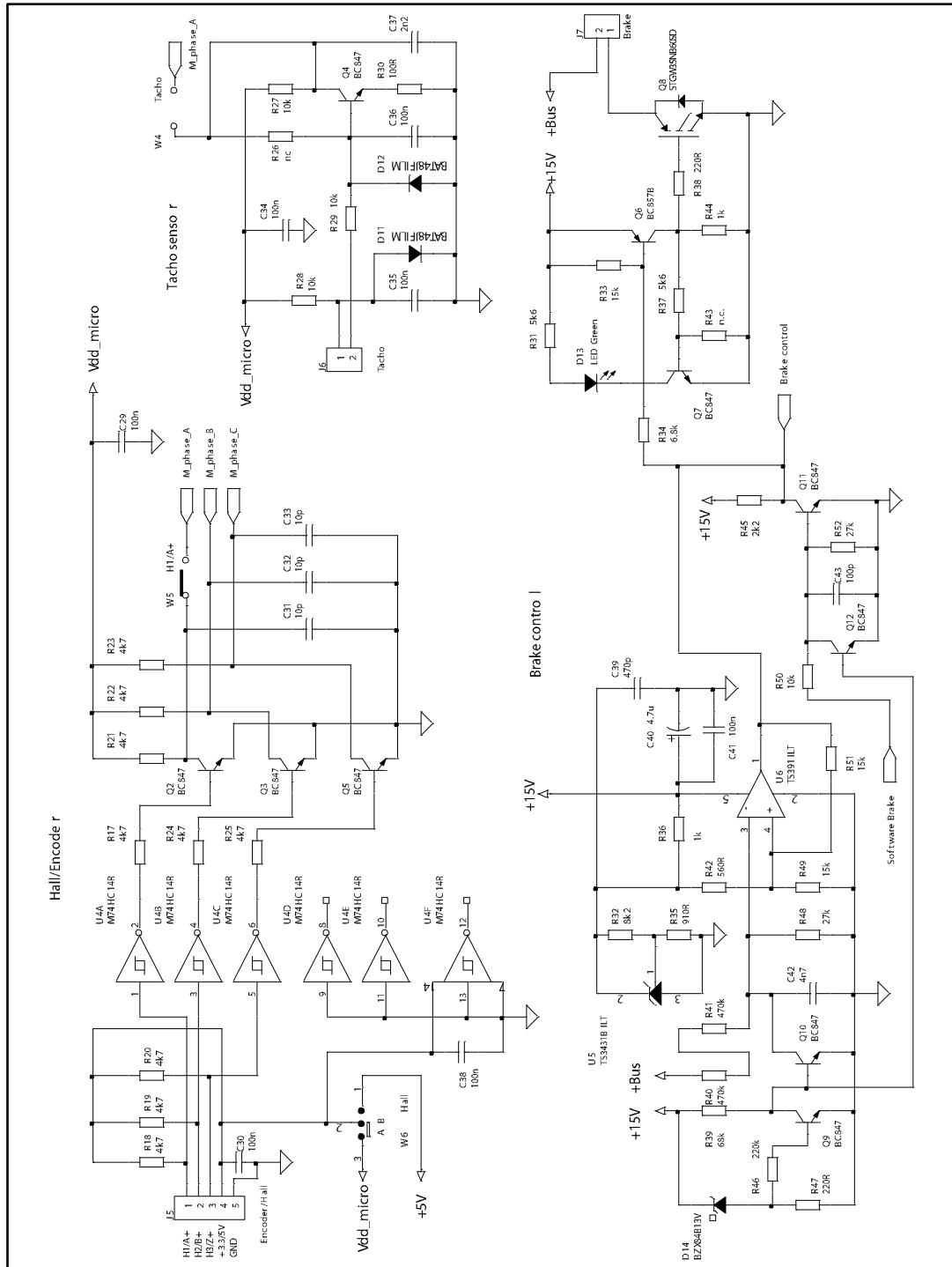

Figure 4: STEVAL-IHM028V2 circuit schematic (4 of 6)

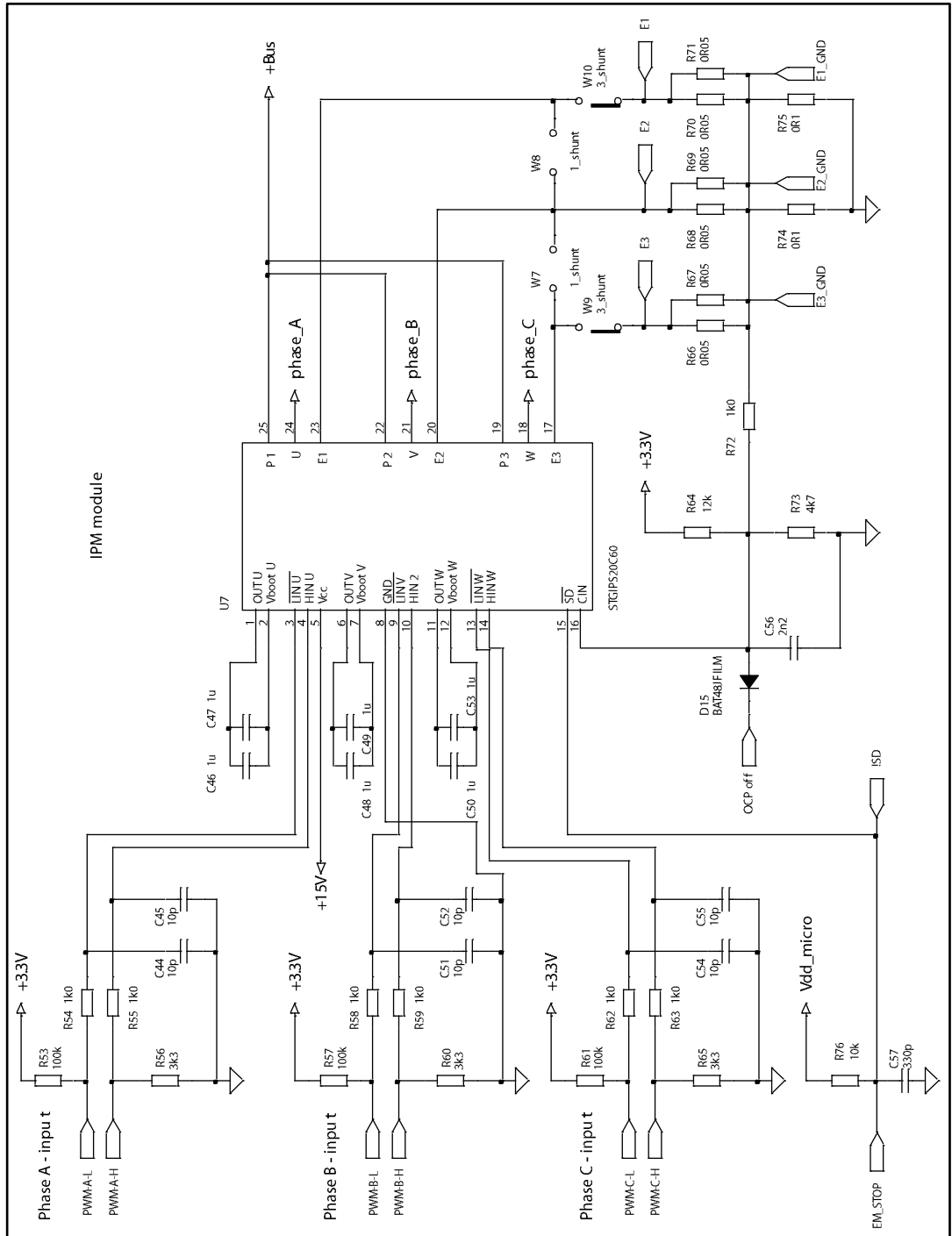

Figure 5: STEVAL-IHM028V2 circuit schematic (5 of 6)

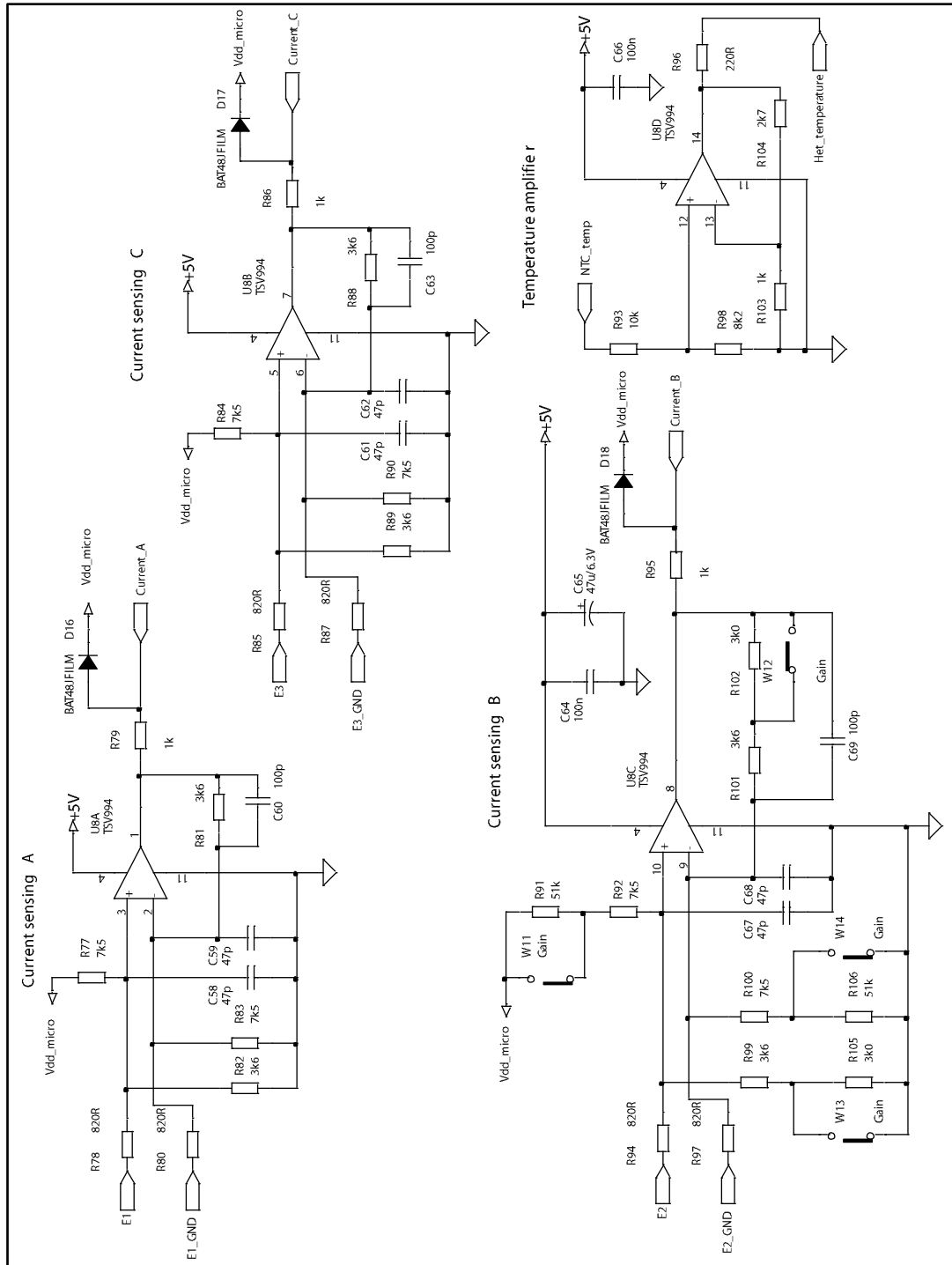
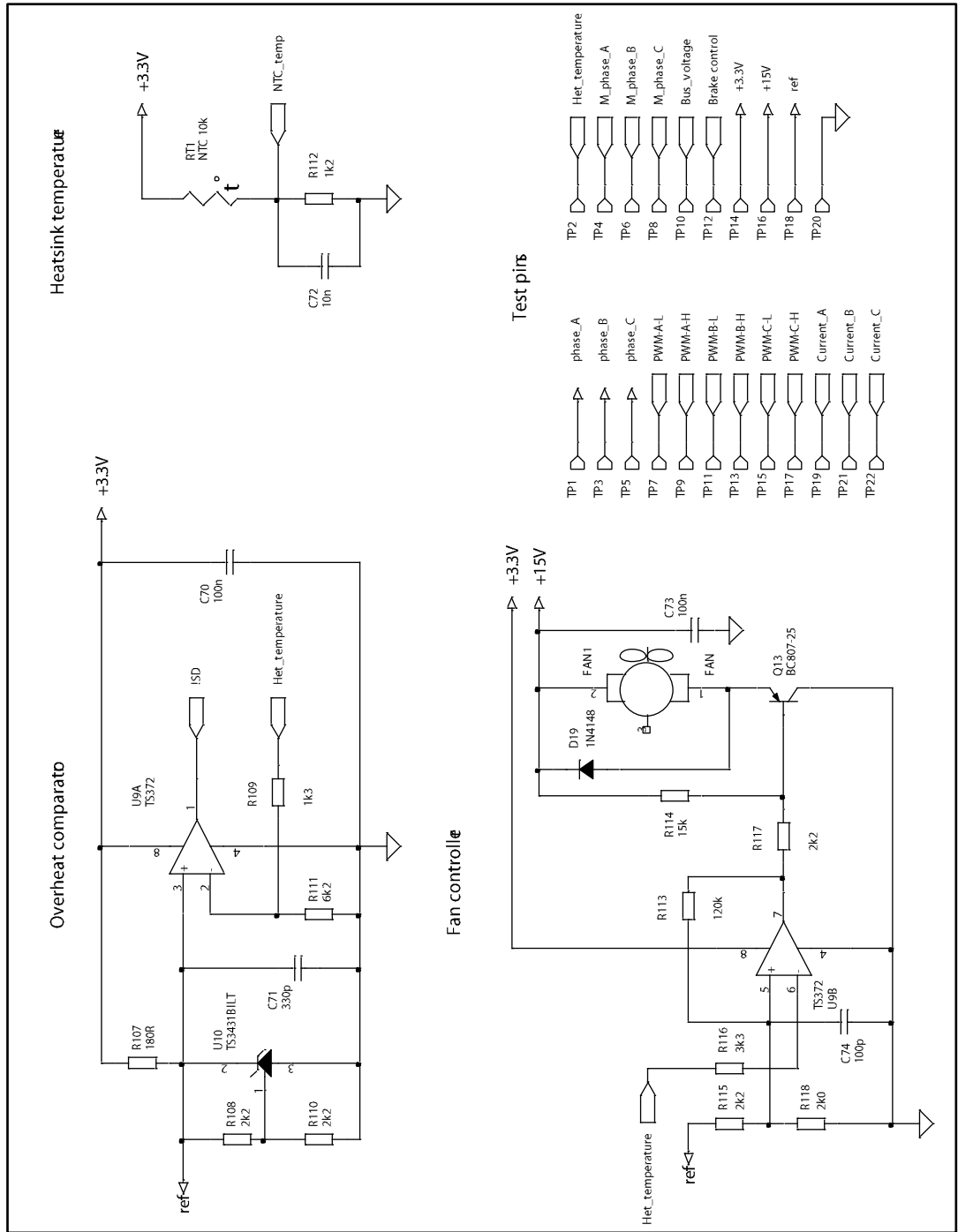

Figure 6: STEVAL-IHM028V2 circuit schematic (6 of 6)



2 Revision history

Table 1: Document revision history

Date	Version	Changes
22-Jul-2014	1	Initial release.
23-Aug-2017	2	Updated <i>Figure 1: "STEVAL-IHM028V2 circuit schematic (1 of 6)"</i> .

IMPORTANT NOTICE – PLEASE READ CAREFULLY

STMicroelectronics NV and its subsidiaries ("ST") reserve the right to make changes, corrections, enhancements, modifications, and improvements to ST products and/or to this document at any time without notice. Purchasers should obtain the latest relevant information on ST products before placing orders. ST products are sold pursuant to ST's terms and conditions of sale in place at the time of order acknowledgement.

Purchasers are solely responsible for the choice, selection, and use of ST products and ST assumes no liability for application assistance or the design of Purchasers' products.

No license, express or implied, to any intellectual property right is granted by ST herein.

Resale of ST products with provisions different from the information set forth herein shall void any warranty granted by ST for such product.

ST and the ST logo are trademarks of ST. All other product or service names are the property of their respective owners.

Information in this document supersedes and replaces information previously supplied in any prior versions of this document.

© 2017 STMicroelectronics – All rights reserved