

DC353A DEMO BOARD QUICK START GUIDE

DESCRIPTION

Demonstration circuit DC353A demonstrates the capabilities of the LTC1928-5 doubler charge pump and linear regulator. The board contains the following:

- LTC1928-5 doubler charge pump with low noise linear regulator.
- 4.7 μ F ceramic capacitor on V_{OUT}
- 4.7 μ F ceramic capacitor on CPO
- 4.7 μ F ceramic capacitor on V_{IN}
- 0.47 μ F ceramic capacitor between CP and CN/SHDNB
- N-channel FET type 2N7002 to supply an open-drain pulldown during shutdown
- 50 Ω termination resistor at the gate of the 2N7002 FET
- A 100 Ω current-limit resistor between the drain of the 2N7002 FET and the CN/SHDNB pin

The LTC1928-5 generates a low noise regulated 5V output from a DC input supply voltage connected to the V_{IN} terminal. The DC supply voltage range is 2.7V to 4.4V. The small SOT-23 package and small ceramic capacitors minimize board space requirements. A power supply connected to V_{IN} is the only requirement for basic operation of the demo board. The termination resistor at the gate of the 2N7002 keeps this FET off and the LTC1928-5 out of shutdown (enabled).

EXTERNAL CONNECTIONS

Refer to Figure 1 for proper power supply and test equipment setup.

Connect a 2.7V to 4.4V DC voltage supply to the V_{IN} terminal.

Connect the DC supply ground to the GND terminal.

Connect a pulse generator switching from 0V to 5V to the SHDN terminal (optional). The part will be enabled when the pulse generator signal is low and disabled when the pulse generator signal is high. If the pulse generator is not connected the part will be enabled.

Connect the load between the V_{OUT} and GND terminals directly at the board if noise measurements are being performed.

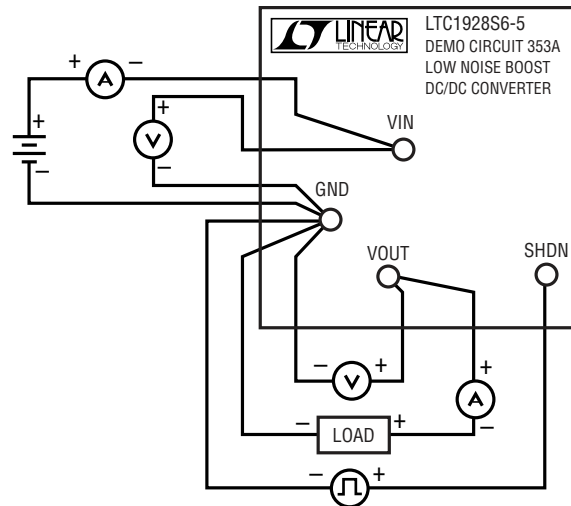

Figure 1. DC353 Test and Measurement Setup

OPERATING MODES

DC353A is designed to demonstrate the low noise performance of the LTC1928-5 as well as its shutdown and current-drive capabilities.

Enable Mode

The device is enabled when the SHDN signal is at 0V. V_{OUT} will be between 4.9V and 5.1V. Noise measurements can be performed as outlined in the LTC1928-5 data sheet. Loads should be applied between the V_{OUT} and the GND terminals on the demo board to avoid ground loops. Ground loops could result in excessive noise generation. A variable resistor or current source can be applied to the V_{OUT} terminal to characterize the output current drive capabilities.

Shutdown Mode

The 2N7002 FET is required to place the LTC1928-5 in shutdown. Shutdown is achieved by applying five volts to the SHDN terminal which turns the 2N7002 on. The 50Ω termination resistor at the SHDN terminal minimizes ringing when the user controls

shutdown using a pulse generator. The pulse generator can be set to switch between 0V and 5V. The enable and disable characteristics can be determined by observing the output voltage at V_{OUT} and the input current at V_{IN} . The pulse generator frequency will be in the 100s of Hertz range. When the part is disabled, V_{OUT} will be discharged to ground via an internal pull down transistor. The data sheet contains example waveforms showing the on and off characteristics of V_{OUT} . In actual applications, the 2N7002 can be replaced with an open-drain transistor associated, for example, with a system controller.