

## Module Front

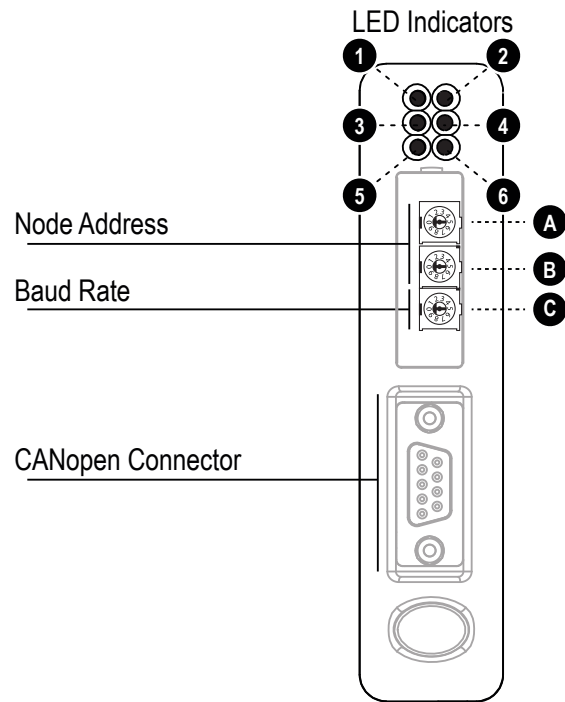

## LED Indicators

LED no	Indication	Meaning
1 (Run)	Off Single flash Blinking On	No power Device in "Stopped" mode Device in "Preoperational" mode Device in "Operational" mode
2 (Error)	Off Single flash Double flash Triple flash On	No error Warning limit reached Error control event Sync error Bus off
3 (Status)	Off Red	Normal operation Unrecoverable fault detected
4 (Power)	Off Green	No power Powered
5 (Subnet Status)	Flashing green Green Red	Running, but one or more transaction errors Running Transaction error/timeout or subnet stopped
6 (Device Status)	Off Alternating red/green Green Flashing green Red Flashing red	Power off Invalid or missing configuration Initializing Running Bootloader mode Note the flash sequence pattern and contact the HMS support department

## Node Address (Switches A and B)

Set the CANopen node address by using the switches as follows:  
Node address = (switch B \* 10) + (switch A \* 1)

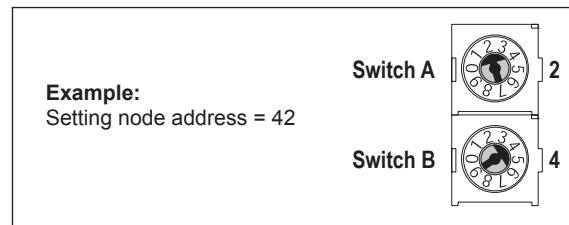

## Baud Rate (Switch C)

#	Baud rate	#	Baud rate
0	(reserved)	5	250 kbit/s
1	10 kbit/s	6	500 kbit/s
2	20 kbit/s	7	800 kbit/s
3	50 kbit/s	8	1 Mbit/s
4	125 kbit/s	9	(reserved)

## CANopen Connector

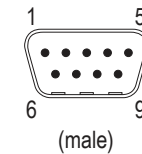

Pin no	Description
2	CAN_L
3	CAN_GND
5	CAN_SHLD
6	GND (optional ground)
7	CAN_H
1, 4, 8, 9	NC
Housing	CAN_SHLD

## Accessories Checklist

The following items are required for installation:

- Anybus Communicator Resource CD (includes configuration software, manuals and application notes)
- RS232 configuration cable
- Subnetwork connector
- CANopen network cable and connector (not included)

## Installation and Startup Summary

- Mount the Communicator on the DIN-rail.
- Connect the Communicator to the CANopen network.
- Connect the Communicator to the subnetwork.
- Power on the Communicator (+24 V DC).
- Connect the configuration cable between the Communicator and the PC containing the Anybus Configuration Manager software (ACM).
- Configure the Communicator using ACM.
- Configure and start the CANopen network.

## Bottom View

PC Connector:

1. GND
2. GND
3. RS232 Rx
4. RS232 Tx

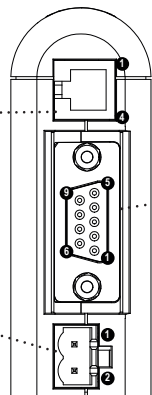

Power:

1. +24 V DC
2. GND

Subnetwork Connector

Pin no.	Description
1	+5V OUT
2	RS232 Rx
3	RS232 Tx
4	NC
5	Signal GND
6	RS422 Rx+
7	RS422 Rx-
8	RS485+ / RS422 Tx+
9	RS485- / RS422 Tx-

**UL Certification**



IND: CONT. EQ.  
FOR HAZ LOC.  
CL I, DIV 2  
GP A,B,C,D  
TEMP  
CODE  
E203225

**Warnings**

- **WARNING - EXPLOSION HAZARD - SUBSTITUTION OF ANY COMPONENTS MAY IMPAIR SUITABILITY FOR CLASS I, DIVISION 2.**
- **WARNING - EXPLOSION HAZARD - WHEN IN HAZARDOUS LOCATIONS, TURN OFF POWER BEFORE REPLACING OR WIRING MODULES.**
- **WARNING - EXPLOSION HAZARD - DO NOT DISCONNECT EQUIPMENT UNLESS POWER HAS BEEN SWITCHED OFF OR THE AREA IS KNOWN TO BE NONHAZARDOUS.**

**Attention!**

- **ATTENTION – RISQUE D’EXPLOSION – LE REMPLACEMENT DE TOUT COMPOSANTS INVALIDE LA CERTIFICATION CLASS I, DIVISION 2.**
- **ATTENTION – RISQUE D’EXPLOSION – EN ZONE EXPLOSIVE, VEUILLEZ COUPER L’ALIMENTATION ÉLECTRIQUE AVANT LE REMPLACEMENT OU LE RACCORDEMENT DES MODULES.**
- **ATTENTION – RISQUE D’EXPLOSION – NE PAS DÉCONNECTER L’ÉQUIPEMENT TANT QUE L’ALIMENTATION EST TOUJOURS PRÉSENTE OU QUE LE PRODUIT EST TOUJOURS EN ZONE EXPLOSIVE ACTIVE.**

**Additional installation and operating instructions**

Max Ambient Temperature: 55°C (for Hazloc environments)

Field wiring terminal markings (wire type (Cu only, 14-30 AWG)).

Use 60/75 or 75°C copper (Cu) wire only.

Terminal tightening torque must be between 5-7 lb-in (0.5 - 0.8 Nm).

Use in overvoltage category 1 pollution degree 2 environment.

Installed in an enclosure considered representative of the intended use.

Secondary circuit intended to be supplied from an isolating source and protected by overcurrent protective devices installed in the field sized per the following:

Control-circuit Wire Size		Maximum Protective Device Rating
AWG	(mm <sup>2</sup> )	Amperes
22	(0.32)	3
20	(0.52)	5
18	(0.82)	7
16	(1.3)	10
14	(2.1)	20
12	(3.3)	25

**EMC Compliance (CE)**



This product is in accordance with the EMC directive 89/336/EEC, with amendments 92/31/EEC and 93/68/EEC through conformance with the following standards:

- **EN 50082-2 (1993)**  
EN 55011 (1990) Class A
- **EN 61000-6-2 (1999)**  
EN 61000-4-3 (1996) 10 V/m  
EN 61000-4-6 (1996) 10 V/m (all ports)  
EN 61000-4-2 (1995) ±8 kV Air Discharge  
±4 kV Contact discharge  
EN 61000-4-4 (1995) ±2 kV Power port  
±1 kV Other ports  
EN 61000-4-5 (1995) ±0.5 kV Power ports (DM/CM)  
±1 kV Signal ports

Further information and documents about this product can be found at the product pages on [www.anybus.com](http://www.anybus.com).