

NOTES: (b)

1. FOR WAVESOLDERING (SOLDER BATH TEMPERATURE 265°C FOR 8 SEC. AND SOLDER PREHEAT 150°C FOR 180 SEC.)
2. IP RATING: IP 67
3. SEALED TO WITHSTAND PRESSURE UP TO 1,45 PSI FOR 30 MINUTES AFTER HIGH TEMPERATURE EXPOSURE
4. METAL SHELL:
 - ZINC DIE CAST; min. 50µin NICKEL PLATING over COPPER
5. INSULATORS: PBT GF UL 94 V-0; BLACK
6. O-RING: SILICONE PER ASTM D2000 70 SHORE A
7. SEALING COMPOUND: EPOXY RESIN UL 94 V-0; BLACK
8. CONTACTS: COPPER ALLOY PLATING (SEE PART NO):
 - PLEASE ADD 1 for 30µin HARD GOLD over min. 50µin NICKEL
 - PLEASE ADD 3 for 8µin HARD GOLD over min. 50µin NICKEL
9. METAL BRACKETS: ZINC DIE CAST; 300µin COPPER/40-120µin NICKEL/120-200µin TIN
10. WASHERS: COPPER ALLOY; 80µin NICKEL
11. HEXLOCKING SCREWS: STAINLESS STEEL
12. FIXING-PLATE: PBT GF UL 94 V-0; BLACK
13. PCB-SNAPS: COPPER ALLOY; min. 200µin TIN over 80µin NICKEL
PCB-HOLE: $\varnothing 3.1 \pm 0.1$; PCB THICKNESS 1.6mm
14. P.C.B. HOLE DRILLINGS and RECOMMENDED PANEL CUT-OUT ON SHEET 2
15. RECOMMENDED TORQUE FOR MOUNTING SCREW 35Ncm (3.1 in.LB) / max. 67Ncm (6 in.LB)
16. OPERATING TEMPERATURE: -40°C to +105°C
17. CONNECTOR IS PART MARKED: 15-00225 CONEC ABC

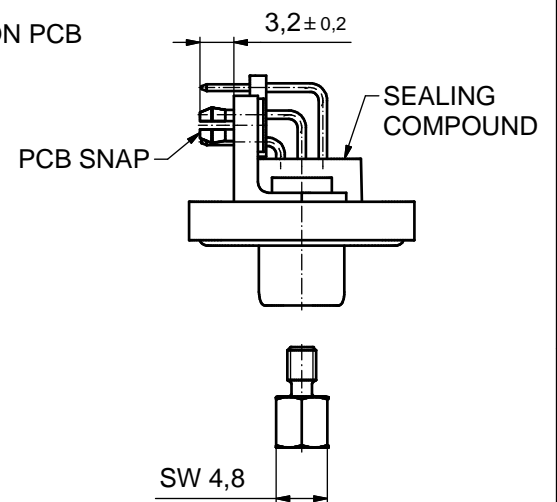
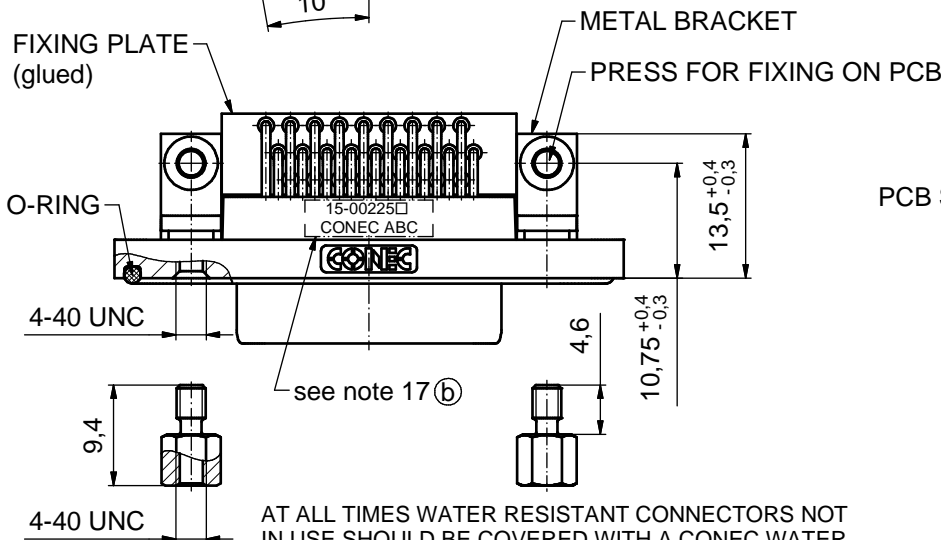
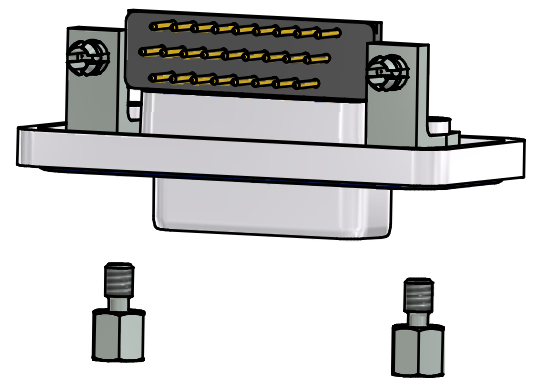
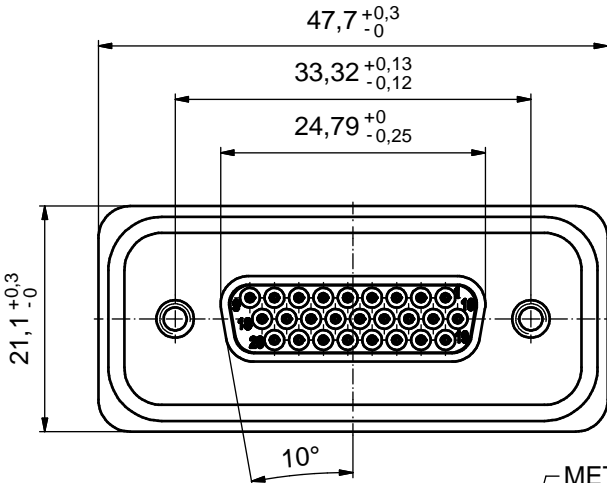
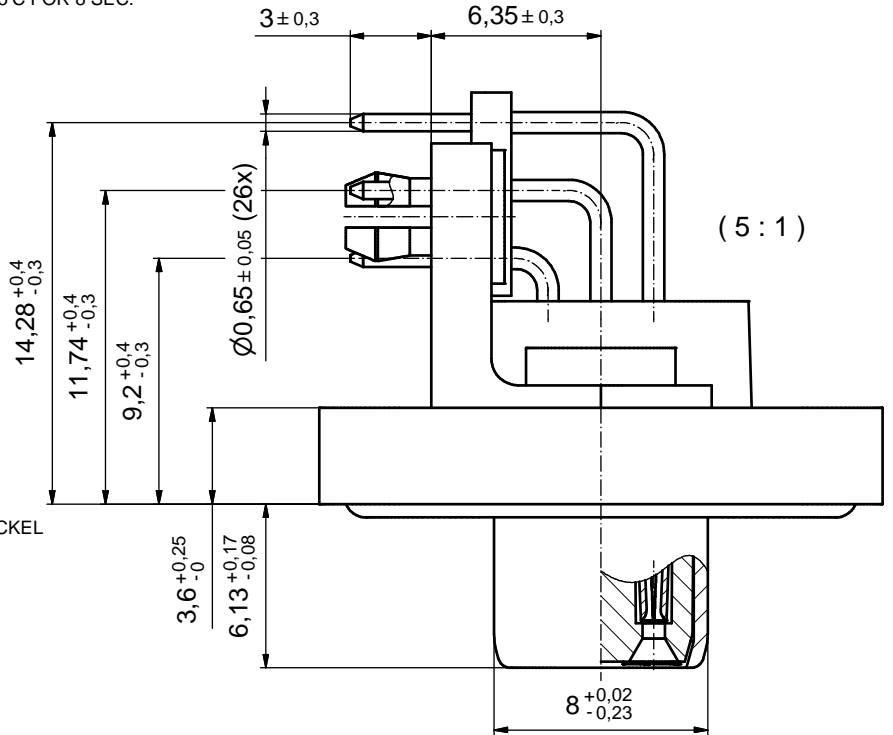

AT ALL TIMES WATER RESISTANT CONNECTORS NOT IN USE SHOULD BE COVERED WITH A CONEC WATER RESISTANT CAP OR WATER TIGHT HOOD.

RoHS compliant

THIS DRAWING MAY NOT BE COPIED OR REPRODUCED IN ANY WAY, AND MAY NOT BE PASSED ON TO A THIRD PARTY WITHOUT WRITTEN PERMISSION. OWNERSHIP AND COPYRIGHT OF CONEC GmbH DO NOT ALTER CAD DRAWING BY HAND				tolerance			scale:	2:1 (5:1)	
				dim. in mm			material:	see notes	
2 x b a rev.				date	name	title: D-SUB HD FEMALE 90° 26pos. SOLDER PIN ANGLED metal bracket, fixing-plate, hexlocking screw, snap dwg no: 15K1A513 part no: 15-00225 (see note 8)			
				drawn	24.11.09				Schmidt
				appd.	27.11.09				Fischer
				norm					
description				d-old		DIN-A3 sh: 1			
									15-00225 (see note 8)

P.C.B. HOLE DRILLINGS

(P.C.B. TOP SIDE)

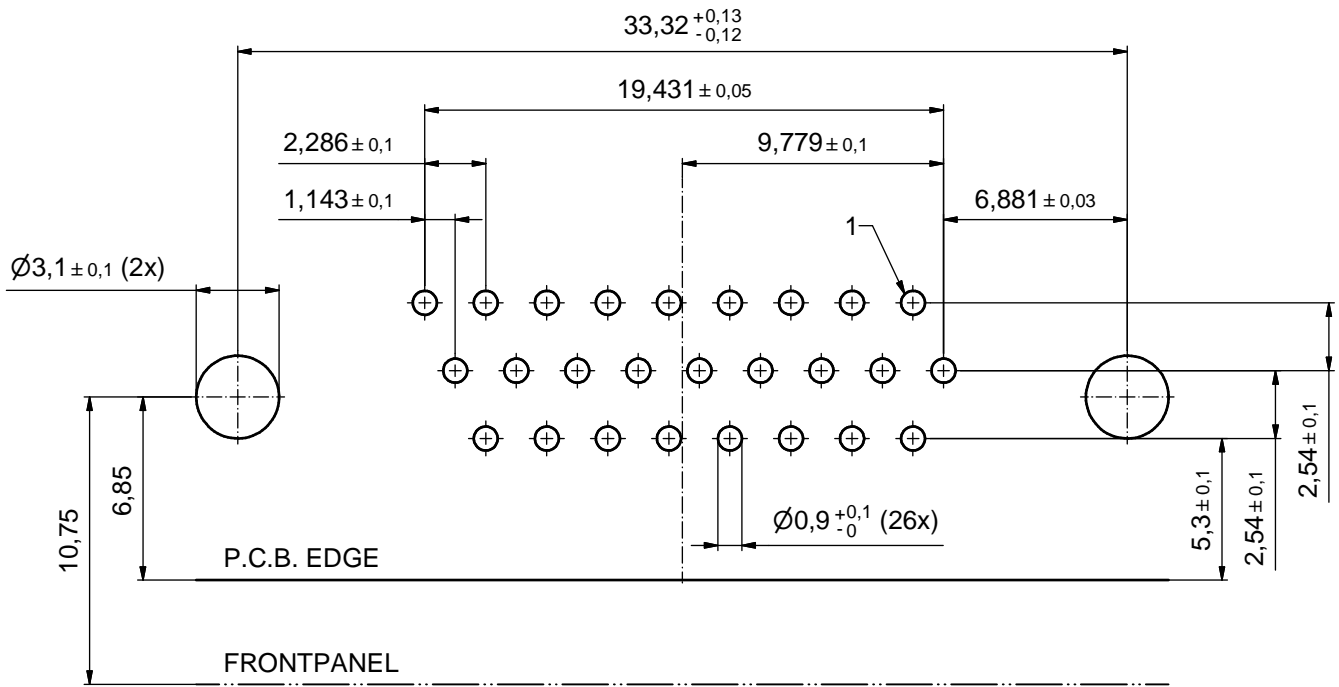

RECOMMENDED PANEL CUT-OUT

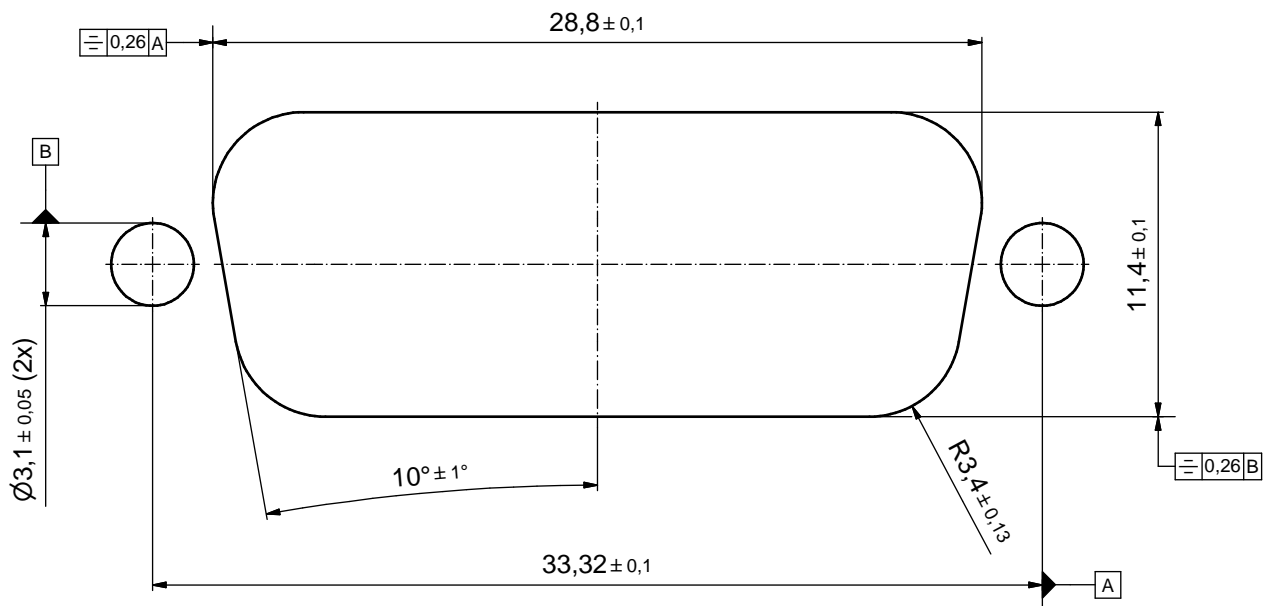

THIS DRAWING MAY NOT BE COPIED OR REPRODUCED IN ANY WAY, AND MAY NOT BE PASSED ON TO A THIRD PARTY WITHOUT WRITTEN PERMISSION. OWNERSHIP AND COPYRIGHT OF CONEC GmbH DO NOT ALTER CAD DRAWING BY HAND				tolerance		scale: 5:1
				dim. in mm		material: see sheet 1
	drawn	24.11.09	Schmidt	date	name	title: P.C.B. HOLE DRILLINGS RECOMMENDED PANEL CUT-OUT D-SUB HD Female 26pos. Solder pin angled 90°
	appd.	27.11.09	Fischer	norm	d-old	
	rev.	a	Original	description	date	name
						DIN-A3 sh: 2
					part no: SEE SHEET 1	