

THIS DRAWING IS UNPUBLISHED. RELEASED FOR PUBLICATION
 © COPYRIGHT BY TYCO ELECTRONICS CORPORATION. ALL RIGHTS RESERVED.

LOC	DIST	REVISIONS					
AD	00	P	LTR	DESCRIPTION	DATE	DWN	APVD
		L1		REVISED PER ECO-09-020932	07SEP09	KK	AEG

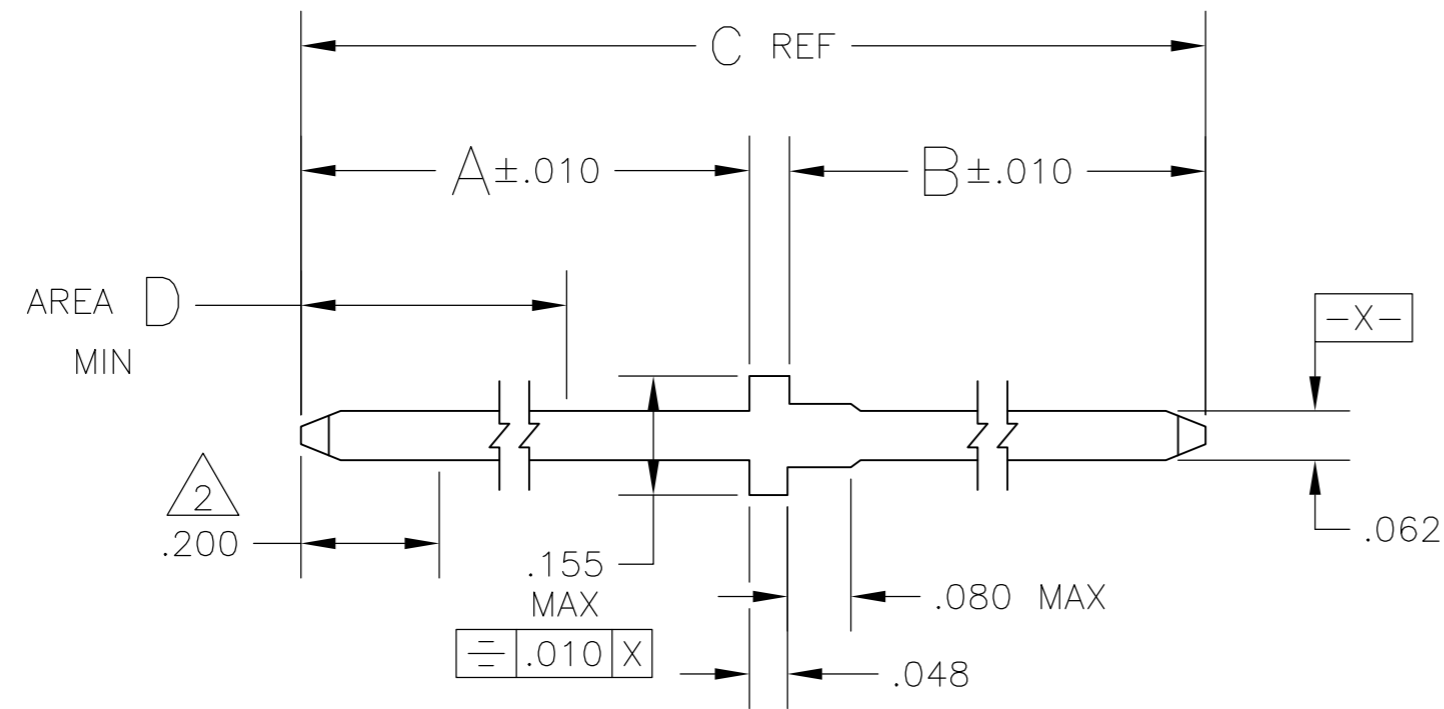

1. THIS POINT IS NOT COMPATIBLE WITH TERMI-POINT APPLICATIONS.
- 2 POINT OF MEASUREMENT FOR PLATING THICKNESS.
- 3 .000015 MIN OVER .000050 MIN NICKEL.
- 4 .000030 MIN GOLD OVER .000050 MIN NICKEL.
- 5 .000010-.000200 BRIGHT TIN OVER .000030 NICKEL.
- 6 .000030 GOLD IN AREA D,.0000100-.000200 BRIGHT TIN-LEAD ON TERMINATION AREA , ALL OVER .000050 NICKEL ENTIRE POST.
- 7 .000050 GOLD IN AREA D,.0000100-.000200 BRIGHT TIN-LEAD ON TERMINATION AREA , ALL OVER .000050 NICKEL ENTIRE POST.
- 8 OBSOLETE PART NUMBER.
- 9 BRASS #4 HARD.
- 10 OBSOLETE PARTS: OBSOLETE CIS STREAMLINING PER D.RENAUD/D.SINISI

D	C	B	A	FINISH	PART NUMBER
.690	.998	.150	.800	7	8 5-86182-1
.640	1.175	.375	.750		8 5-86182-0
.625	.875	.092	.735		8 4-86182-9
.560	.843	.125	.670		8 4-86182-8
.455	.800	.187	.565		8 4-86182-7
.250	.595	.187	.360		8 4-86182-6
.240	.798	.400	.350	7	8 4-86182-5
.890	1.198	.150	1.000	6	8 4-86182-4
.690	.998	.150	.800		8 4-86182-3
.560	.843	.125	.670		8 4-86182-2
.490	1.273	.625	.600		8 4-86182-1
.460	.748	.130	.570		8 4-86182-0
.455	1.143	.530	.565		8 3-86182-9
.455	.800	.187	.565		8 3-86182-8
.370	.715	.187	.480		8 3-86182-7
.290	.573	.125	.400		8 3-86182-6
.270	.748	.320	.380		8 3-86182-5
.250	.595	.187	.360		8 3-86182-4
.240	.798	.400	.350	6	8 3-86182-3
	.828	.530	.250	5	8 3-86182-2
	.798	.400	.350	3	8 3-86182-1
	.595	.187	.360	3	8 3-86182-0
10 OBSOLETE	.573	.125	.400	4	2-86182-9
OBSOLETE	.875	.092	.735	3	8 2-86182-8
	1.198	.150	1.000	5	8 2-86182-7
	.748	.130	.570	5	8 2-86182-6
	.573	.125	.400	5	2-86182-5
	.798	.400	.350	4	8 2-86182-4
	.843	.125	.670	5	8 2-86182-3
	.715	.187	.480	5	2-86182-2
	1.175	.375	.750	3	8 2-86182-1
	.748	.130	.570	4	8 2-86182-0
	.798	.400	.350	5	8 1-86182-9
	.715	.187	.480	4	1-86182-8
	.843	.125	.670	3	8 1-86182-7
	1.198	.150	1.000	4	8 1-86182-6
	.748	.320	.380	4	1-86182-5
	.800	.187	.565	3	8 1-86182-4
	.998	.150	.800	3	8 1-86182-3
	.843	.125	.670	4	1-86182-1
	.998	.150	.800	5	1-86182-0
10 OBSOLETE	.748	.320	.380	5	86182-9
	.800	.187	.565	4	86182-8
	.595	.187	.360	4	86182-7
	1.143	.530	.565	4	8 86182-6
	1.273	.625	.600	4	8 86182-5
	1.273	.625	.600	5	8 86182-4
	1.143	.530	.565	5	8 86182-3
10 OBSOLETE	.595	.187	.360	5	86182-2
	.800	.187	.565	5	86182-1

THIS DRAWING IS A CONTROLLED DOCUMENT.		DWN B. HAYMAKER 27JAN00	Tyco Electronics Corporation Harrisburg, Pa 17105-3608	
DIMENSIONS: INCHES		CHK M.ZITTO 27JAN00	NAME CONTACT, MALE, MOD 1 LOOSE PIECE .031X.062	
TOLERANCES UNLESS OTHERWISE SPECIFIED: 0 PLC ± - 1 PLC ± - 2 PLC ± - 3 PLC ± 0.13[.005] 4 PLC ± - ANGLES ± -		APVD M.ZITTO 27JAN00	PRODUCT SPEC -	
MATERIAL 9		FINISH -	WEIGHT -	RESTRICTED TO -
CUSTOMER DRAWING		SCALE 4:1	SHEET 1 OF 1	REV L1