

SDCL1V40

Semi-shielded power inductors



Product features

- High current carrying capacity
- High power density, low core losses
- Magnetically semi-shielded
- 4.2 mm x 4.2 mm surface mount package in 1.85 mm, 2.0 mm and 3.0 mm heights
- NiZn ferrite magnetic material
- Moisture sensitivity level (MSL): 1

Applications

- DC-DC converters
- Switching controllers
- Industrial IoT equipment
- Game consoles
- Portable electronics
- Laptops, notebooks, and netbooks
- Desktops and workstations
- Battery backup
- LED lighting
- HD televisions and displays

Environmental compliance and general specifications

- Storage temperature range (component): -40 °C to +125 °C
- Operating temperature range: -40 °C to +125 °C (ambient plus self-temperature rise)
- Solder reflow temperature: J-STD-020 (latest revision) compliant



Product specifications

Part number ⁵	OCL ¹ (µH)	FLL ² (µH) minimum	I _{DC} ³ (A)	I _{pk} ⁴ (A)	DCR (mΩ) @ +20 °C nominal	DCR (mΩ) @ +20 °C maximum
SDCL1V4018						
SDCL1V4018-1R0N-R	1.0±30%	0.46	3.3	4.5	26	30
SDCL1V4018-1R5N-R	1.5±30%	0.68	3.0	3.3	39	46
SDCL1V4018-2R2M-R	2.2±20%	1.14	2.5	3.0	47	54
SDCL1V4018-3R3M-R	3.3±20%	1.72	2.0	2.15	70	81
SDCL1V4018-4R7M-R	4.7±20%	2.44	1.75	2	88	102
SDCL1V4018-6R8M-R	6.8±20%	3.54	1.5	1.6	110	126
SDCL1V4018-100M-R	10±20%	5.2	1.3	1.4	170	196
SDCL1V4018-150M-R	15±20%	7.8	0.9	0.95	270	311
SDCL1V4018-220M-R	22±20%	11.44	0.75	0.8	365	420
SDCL1V4018-330M-R	33±20%	17.16	0.7	0.73	550	633
SDCL1V4018-470M-R	47±20%	24.44	0.55	0.65	780	898
SDCL1V4018-680M-R	68±20%	35.36	0.5	0.55	1000	1150
SDCL1V4018-101M-R	100±20%	52	0.35	0.42	1500	1725
SDCL1V4018-221M-R	220±20%	114.4	0.25	0.3	4200	4830
SDCL1V4020						
SDCL1V4020-R47N-R	0.47±30%	0.21	7.0	10	15	20
SDCL1V4020-1R0M-R	1.0±20%	0.52	5.8	8.7	22	26
SDCL1V4020-1R5M-R	1.5±20%	0.78	4.5	7.7	32	36
SDCL1V4020-2R2M-R	2.2±20%	1.14	4.2	6.1	44	48
SDCL1V4020-3R3M-R	3.3±20%	1.72	3.5	4.7	65	72
SDCL1V4020-4R7M-R	4.7±20%	2.44	2.5	4.0	95	108
SDCL1V4020-6R8M-R	6.8±20%	3.54	2.1	3.0	135	156
SDCL1V4020-100M-R	10±20%	5.2	1.7	2.8	195	216
SDCL1V4030						
SDCL1V4030-R68N-R	0.68±30%	0.31	4.3	8	11	15
SDCL1V4030-1R0N-R	1.0±30%	0.46	3.8	5.9	20	24
SDCL1V4030-1R5N-R	1.5±30%	0.68	3.3	5.8	28	33
SDCL1V4030-2R2M-R	2.2±20%	1.14	2.8	5	34	39
SDCL1V4030-3R3M-R	3.3±20%	1.72	2.4	3.9	45	52
SDCL1V4030-4R7M-R	4.7±20%	2.44	1.9	3.2	67	77
SDCL1V4030-6R8M-R	6.8±20%	3.54	1.6	2.8	100	115
SDCL1V4030-100M-R	10±20%	5.2	1.5	2.2	120	138
SDCL1V4030-150M-R	15±20%	7.8	1.2	1.85	180	207
SDCL1V4030-220M-R	22±20%	11.44	1.0	1.55	265	305
SDCL1V4030-330M-R	33±20%	17.16	0.8	1.0	400	460
SDCL1V4030-470M-R	47±20%	24.44	0.72	0.95	500	575
SDCL1V4030-680M-R	68±20%	35.36	0.5	0.85	980	1127
SDCL1V4030-101M-R	100±20%	52	0.4	0.6	1300	1495
SDCL1V4030-221M-R	220±20%	114.4	0.3	0.4	2600	2990
SDCL1V4030-331M-R	330±20%	171.6	0.25	0.38	4400	5060
SDCL1V4030-471M-R	470±20%	244.4	0.17	0.32	7200	8300

1. Open circuit inductance (OCL) test parameters: 100 kHz, 0.25 Vrms, 0.0 Adc, +25 °C (SDCL1V4020 1.0 MHz, 1.0 Vrms)
 2. Full load inductance (FLL) test parameters: 100 kHz, 0.25 Vrms, Isat, +25 °C (SDCL1V4020 100 kHz, 1.0 Vrms)
 3. I_{DC}: DC current for an approximate temperature rise of 40 °C without core loss. Derating is necessary for AC currents.
 PCB layout, trace thickness and width, air-flow, and proximity of other heat generating components will affect the temperature rise. It is recommended that the temperature of the part not exceed +125 °C under worst case operating conditions verified in the end application.

4. I_{pk}: Peak current for approximately 35% maximum rolloff @ +25 °C
 5. Part number definition: SDCL1Vxxxx-yyyz-R
 SDCL1V = Product code
 xxxx= size code
 yyy= Inductance value in µH, R=decimal point
 z= Inductance tolerance
 -R suffix = RoHS compliant

Dimensions-mm

SDCL1V4018

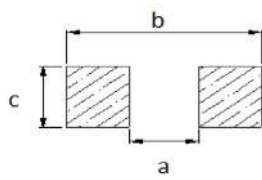
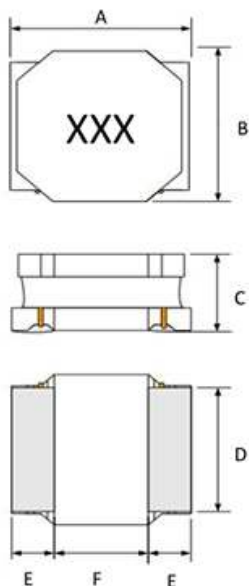

Dimension	Value
A	4.0 + 0.2
B	4.0 + 0.2
C	1.85 maximum
D	3.4 ± 0.2
E	1.2 ± 0.3
F	1.6 ± 0.3
a	1.3 TYP
b	4.3 TYP
c	3.7 TYP

SDCL1V4020

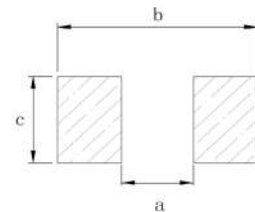
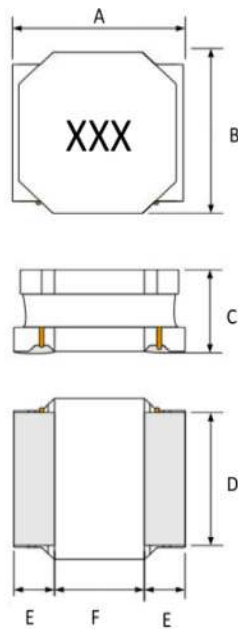

Dimension	Value
A	4.0 + 0.2
B	4.0 + 0.2
C	2.0 maximum
D	3.5 ± 0.2
E	1.0 ± 0.3
F	2.0 ± 0.3
a	1.7 TYP
b	4.3 TYP
c	3.8 TYP

SDCL1V4030

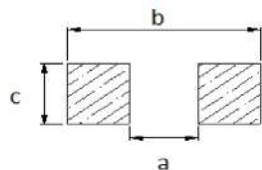
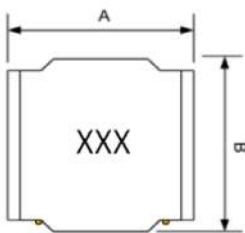

Dimension	Value
A	4.0 + 0.2
B	4.0 + 0.2
C	3.0 maximum
D	3.2 ± 0.2
E	0.95 ± 0.3
F	2.0 ± 0.3
a	1.7 TYP
b	4.3 TYP
c	3.5 TYP

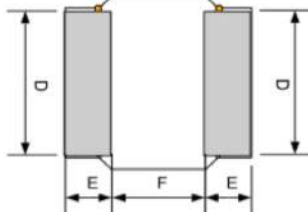

Part marking: xxx= inductance value in uH, R= decimal point. If no R is present then last character equals number of zeros

Tolerances are ±0.3 millimeters unless stated otherwise

All soldering surfaces to be coplanar within 0.1 millimeters

Pad layout tolerances are ±0.1 millimeters unless stated otherwise

Traces or vias underneath the inductor is not recommended

Packaging information- mm

SDCL1V4018

Supplied in tape and reel packaging, 3000 parts per 13" diameter reel (EIA-481 compliant)
Drawing not to scale

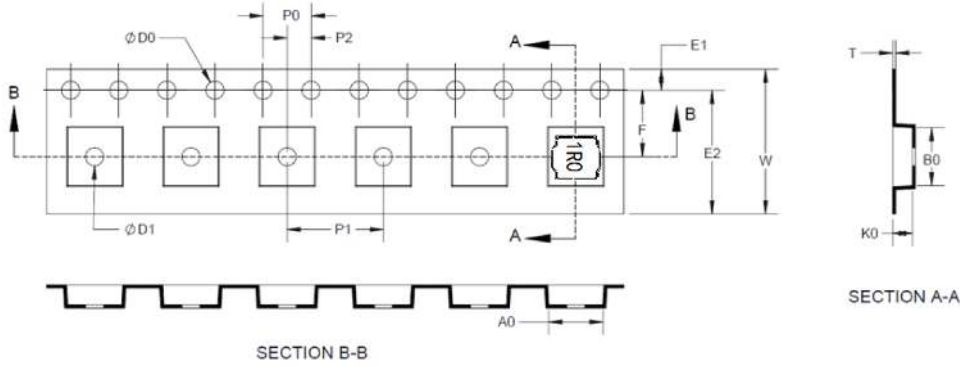

Dimension	Value
W	12.00 ± 0.30
F	5.50 ± 0.10
E1	1.75 ± 0.10
E2	N/A
P0	4.00 ± 0.10
P1	8.00 ± 0.10
P2	2.00 ± 0.10
ØD0	1.50 + 0.10/-0
ØD1	1.50 + 0.10/-0
A0	4.30 ± 0.10
B0	4.30 ± 0.10
K0	2.25 ± 0.10
T	0.30 ± 0.05

Packaging information- mm

SDCL1V4020

Supplied in tape and reel packaging, 3000 parts per 13" diameter reel (EIA-481 compliant)
Drawing not to scale

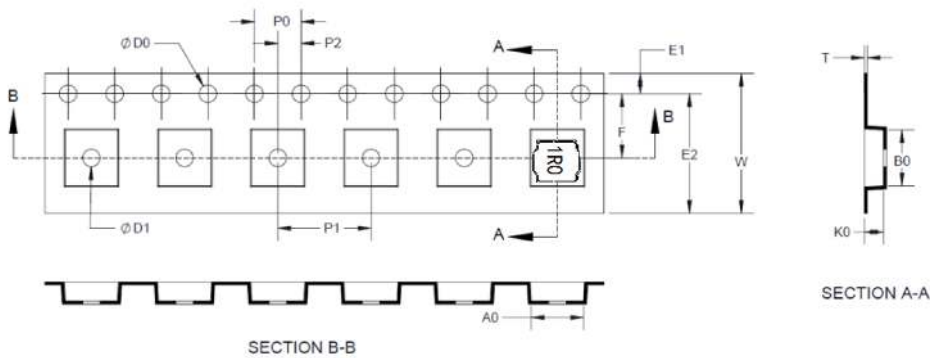

Dimension	Value
W	12.00 ± 0.30
F	5.50 ± 0.10
E1	1.75 ± 0.10
E2	N/A
P0	4.00 ± 0.10
P1	8.00 ± 0.10
P2	2.00 ± 0.10
ØD0	1.50 + 0.10/-0
ØD1	1.50 + 0.10/-0
A0	4.30 ± 0.10
B0	4.30 ± 0.10
K0	2.25 ± 0.10
T	0.30 ± 0.05

Packaging information- mm

SDCL1V4030

Supplied in tape and reel packaging, 2000 parts per 13" diameter reel (EIA-481 compliant)
Drawing not to scale

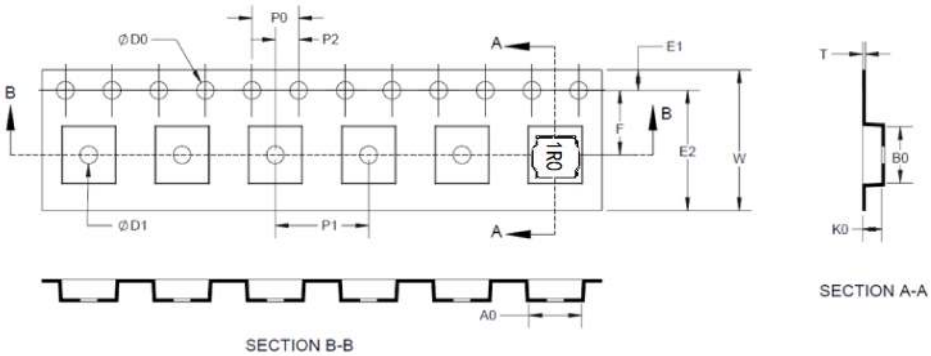

Dimension	Value
W	12.00 ± 0.30
F	5.50 ± 0.10
E1	1.75 ± 0.10
E2	N/A
P0	4.00 ± 0.10
P1	8.00 ± 0.10
P2	2.00 ± 0.10
ØD0	1.50 + 0.10/-0
ØD1	1.50 + 0.10/-0
A0	4.25 + 0.10/-0
B0	4.25 + 0.10/-0
K0	3.25 ± 0.10
T	0.40 ± 0.05

Inductance and temperature rise vs current
SDCL1V4018

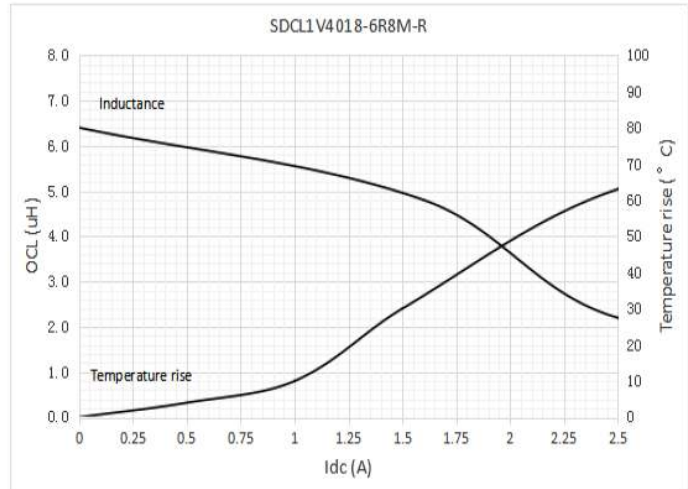
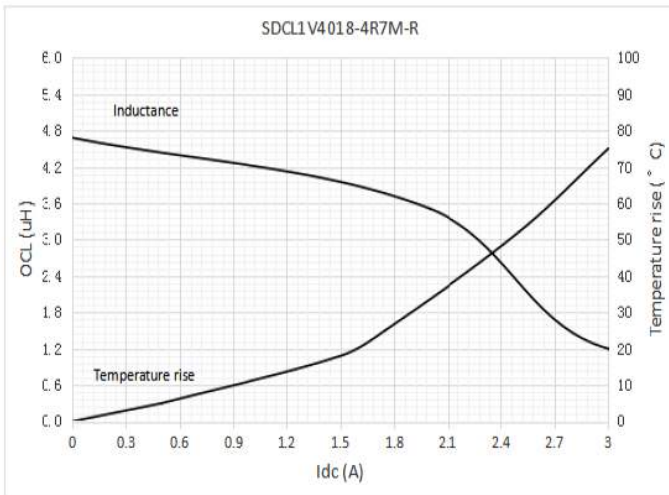
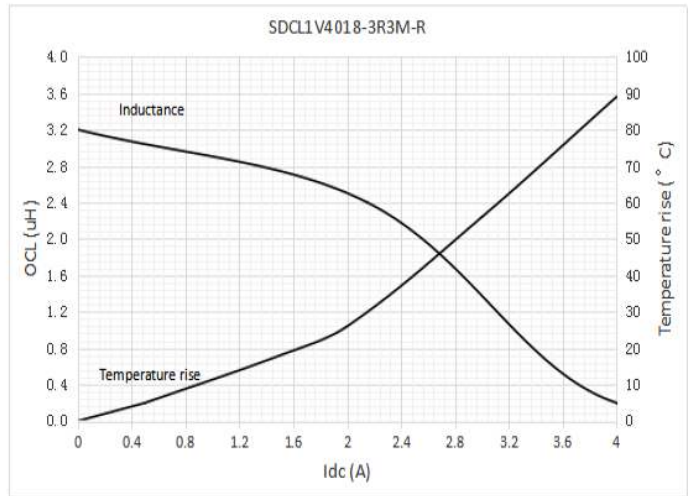
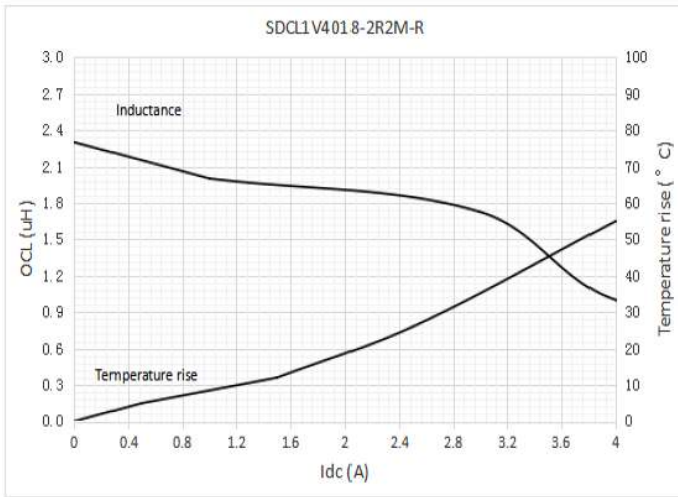
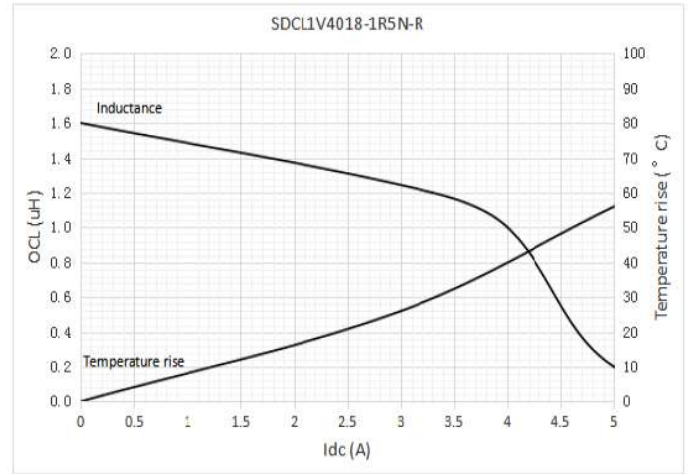
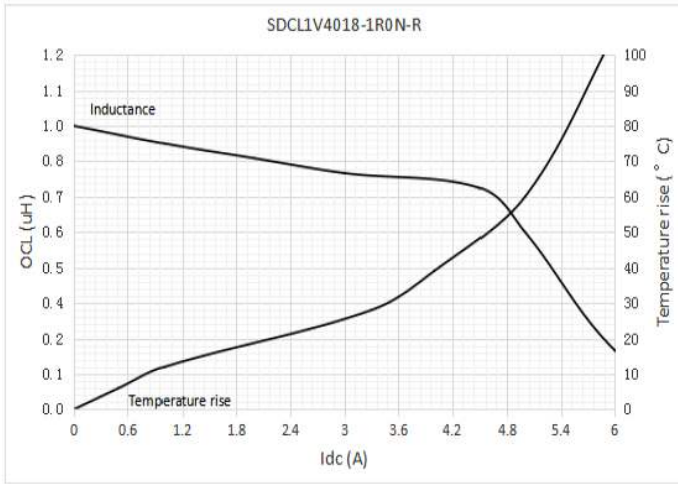

Inductance and temperature rise vs current
SDCL1V4018

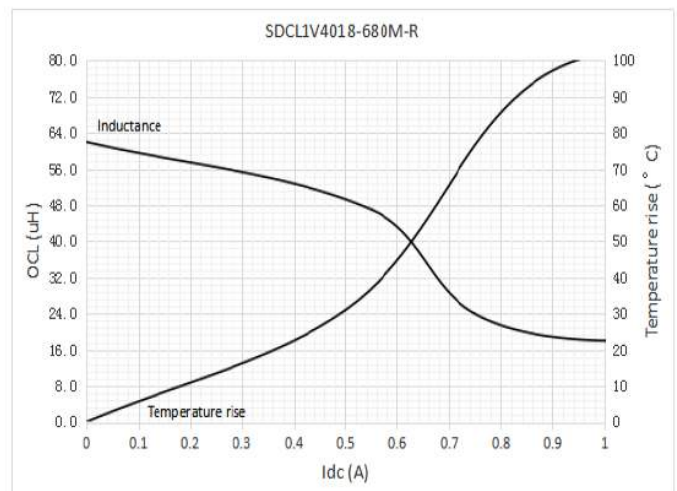
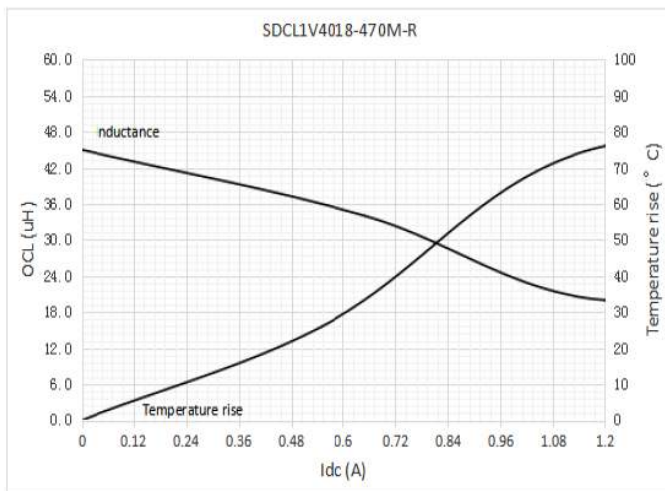
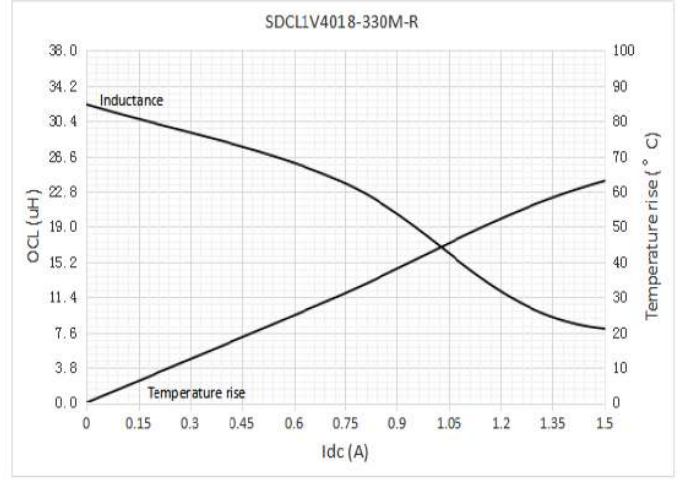
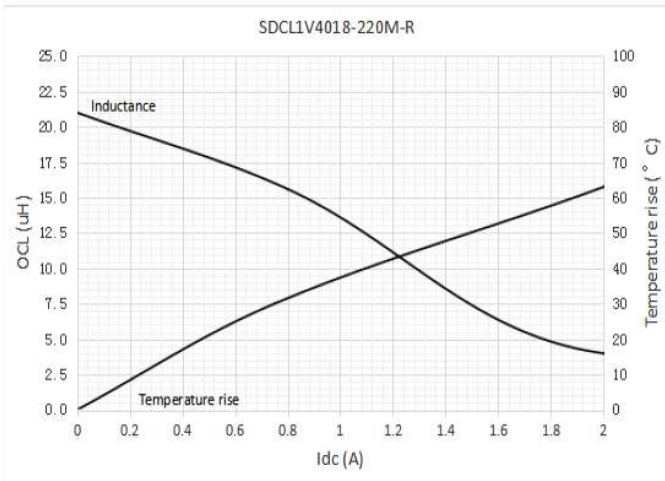
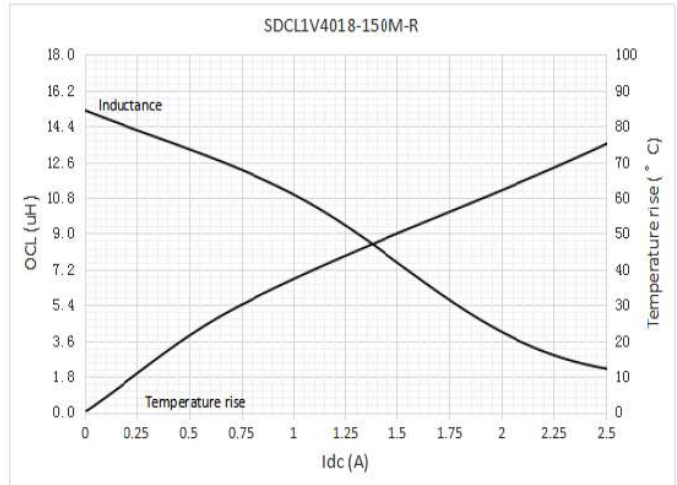
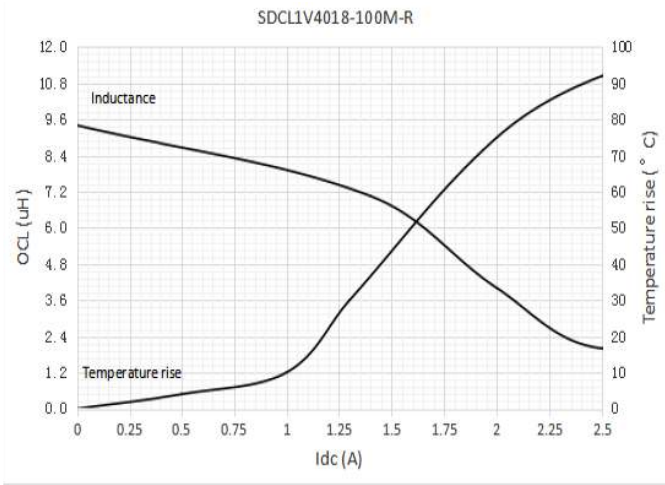

Inductance and temperature rise vs current
SDCL1V4018

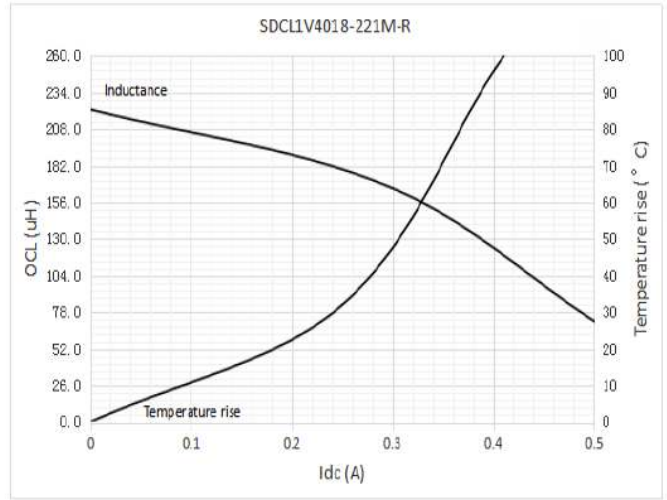
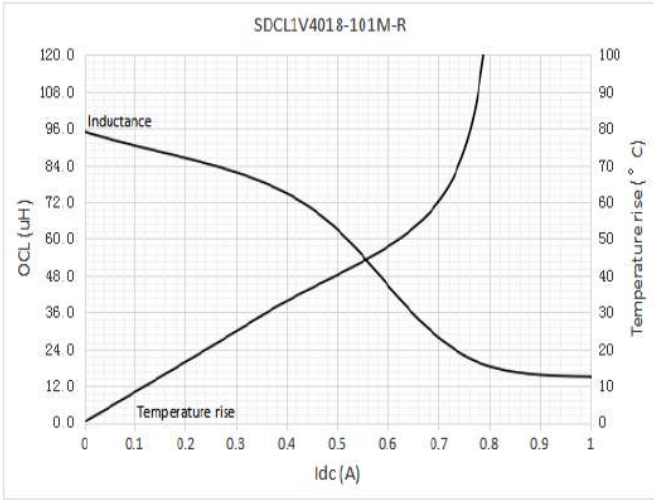

Inductance and temperature rise vs current
SDCL1V4020

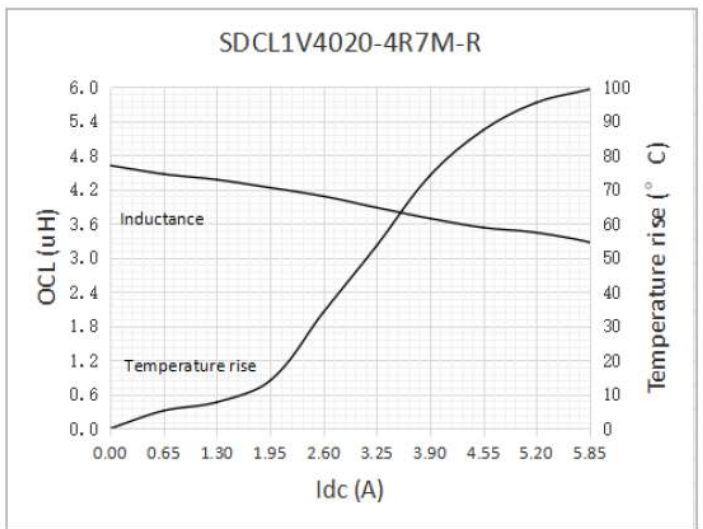
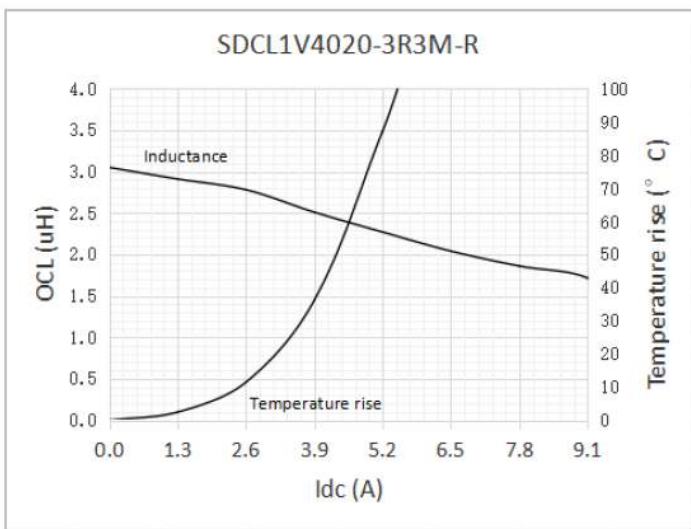
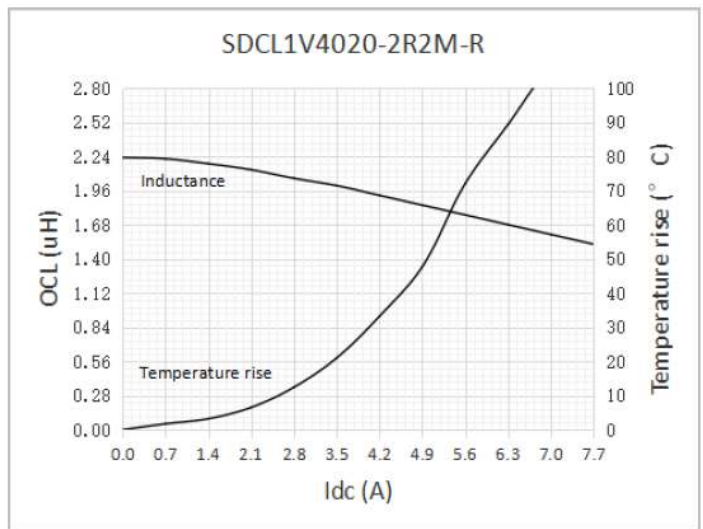
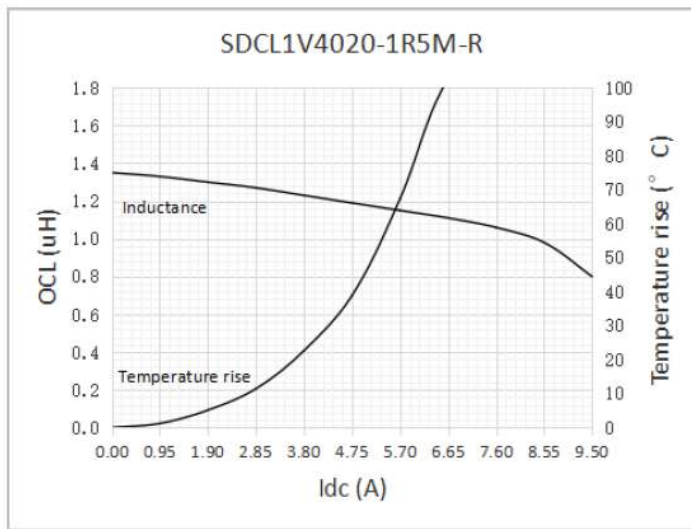
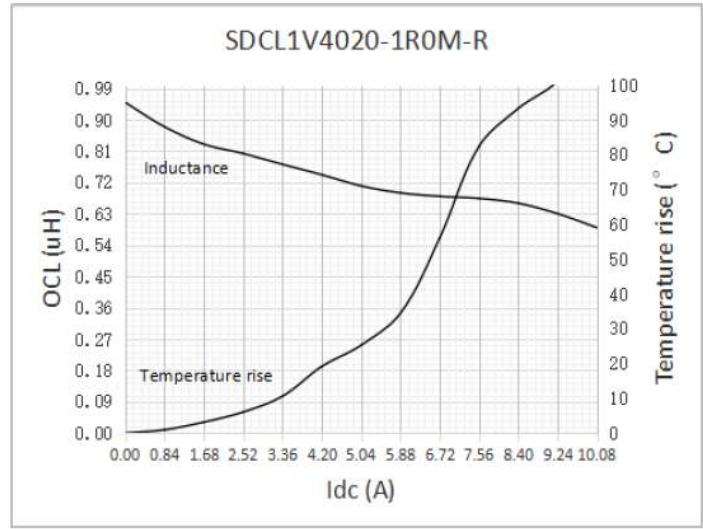
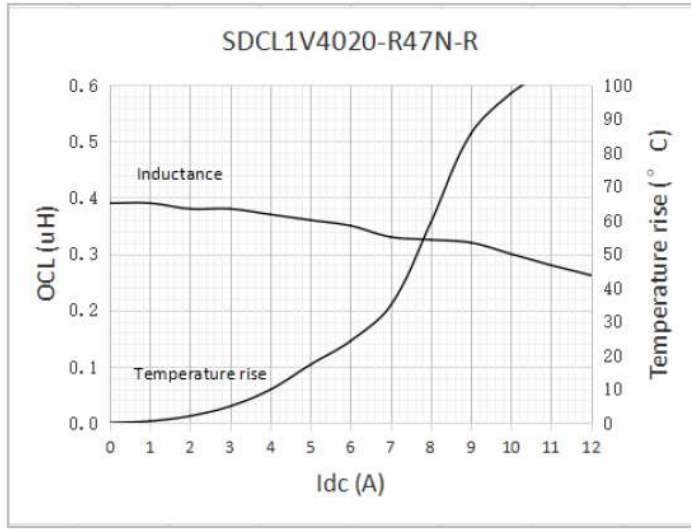

Inductance and temperature rise vs current
SDCL1V4020

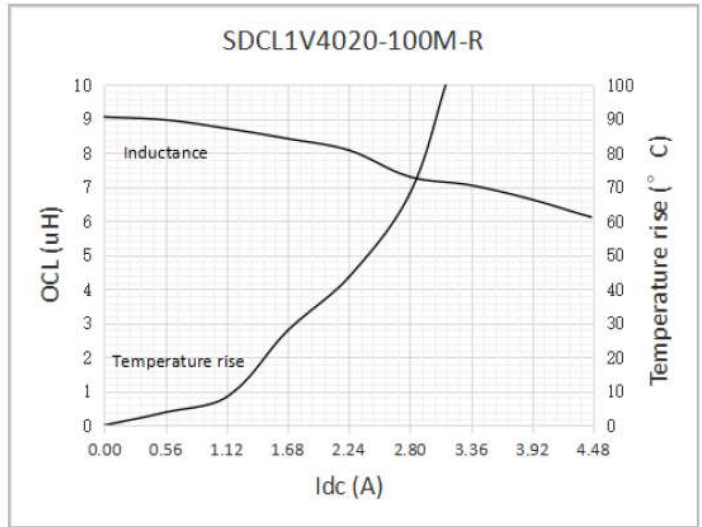
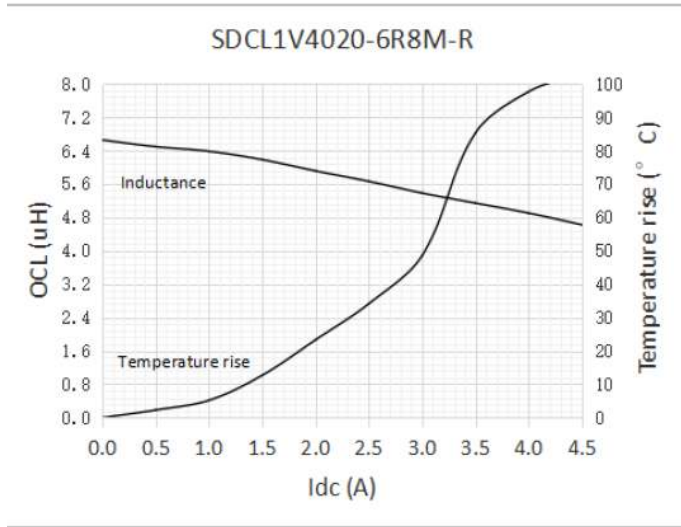

Inductance and temperature rise vs current
SDCL1V4030

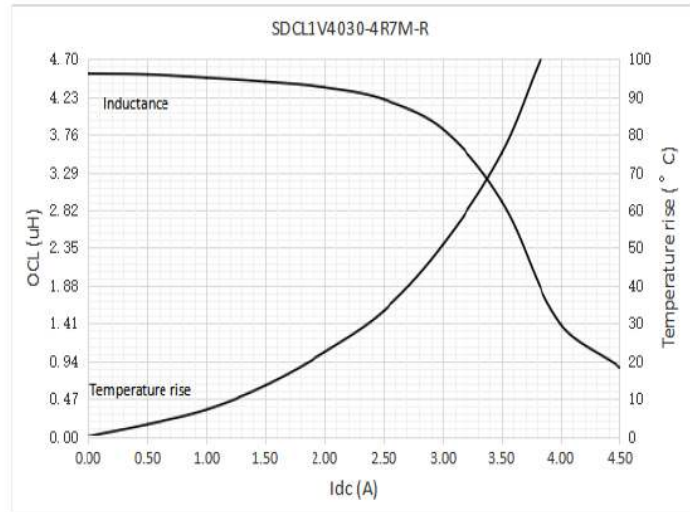
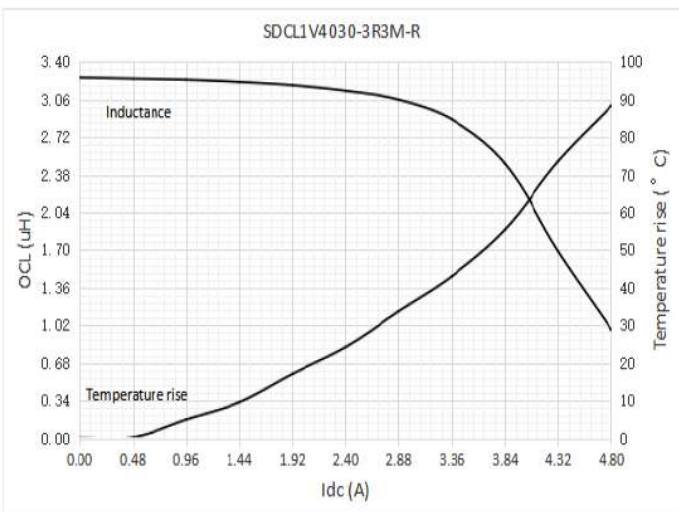
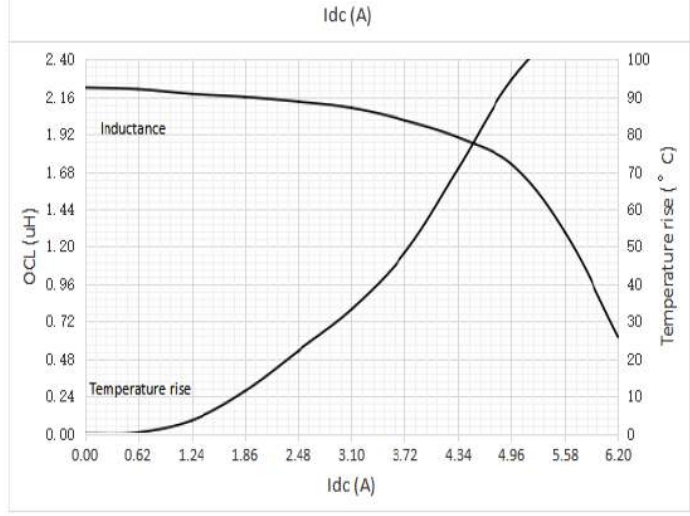
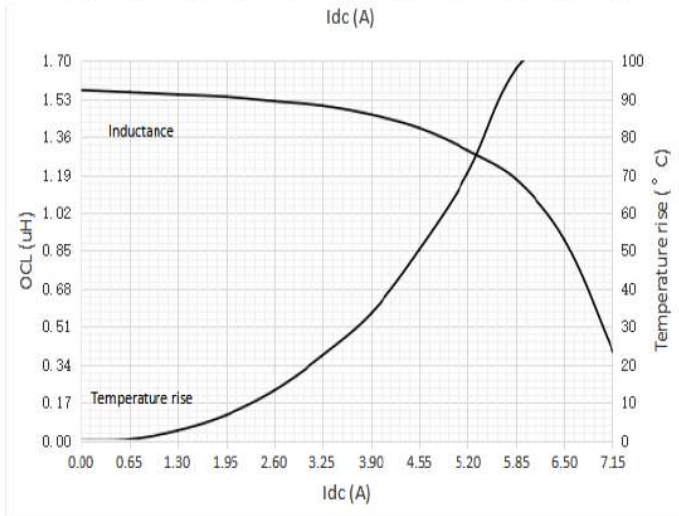
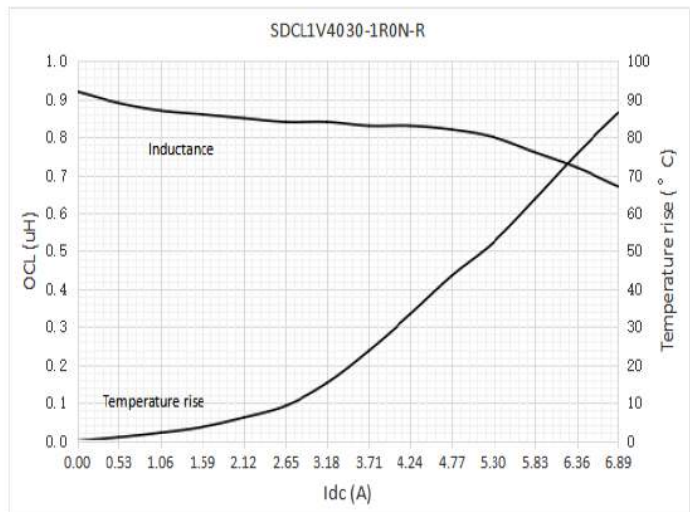
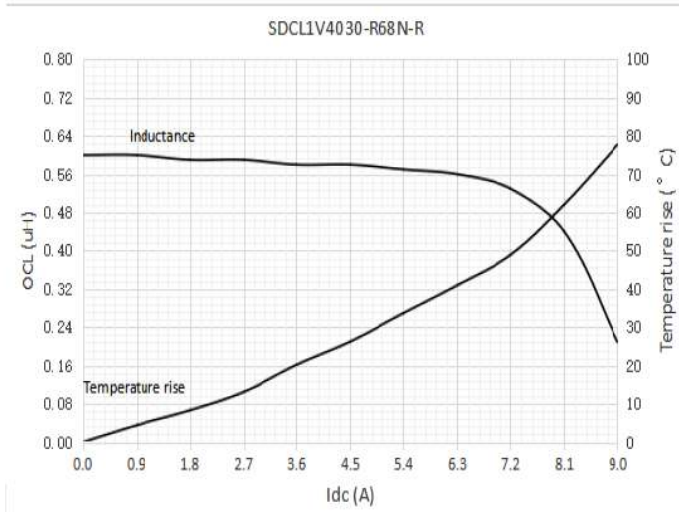

Inductance and temperature rise vs current
SDCL1V4030

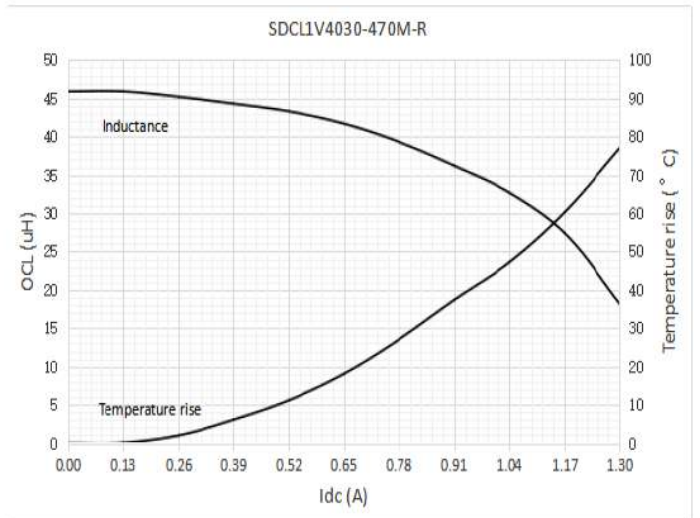
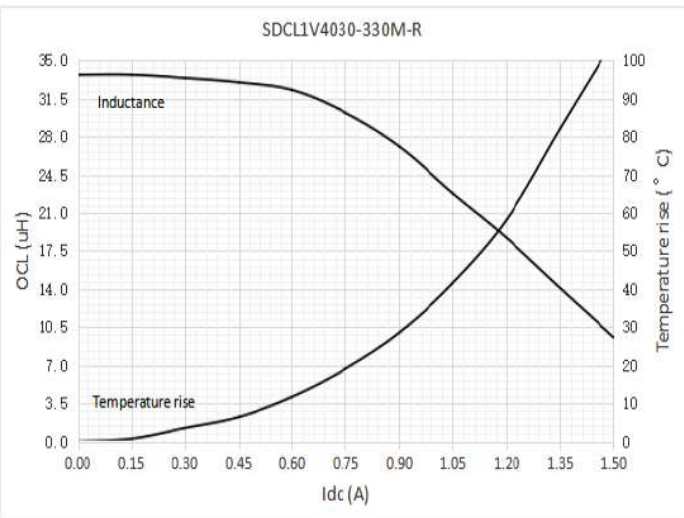
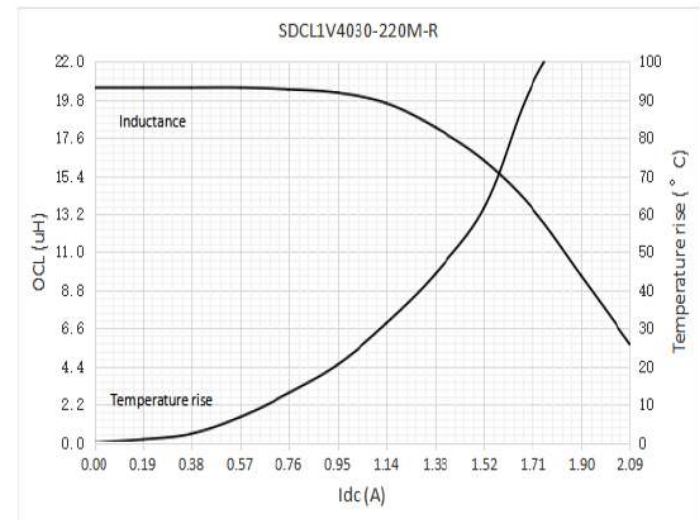
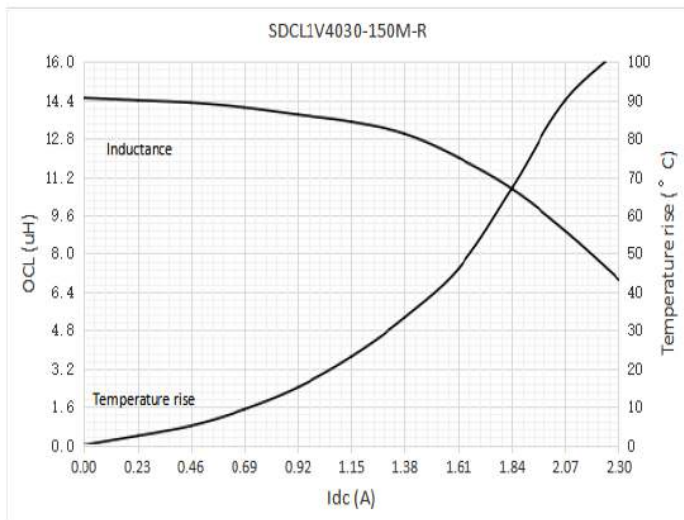
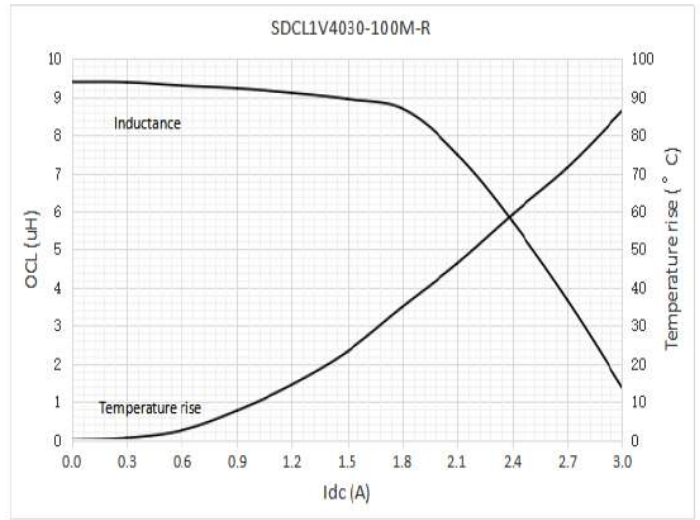
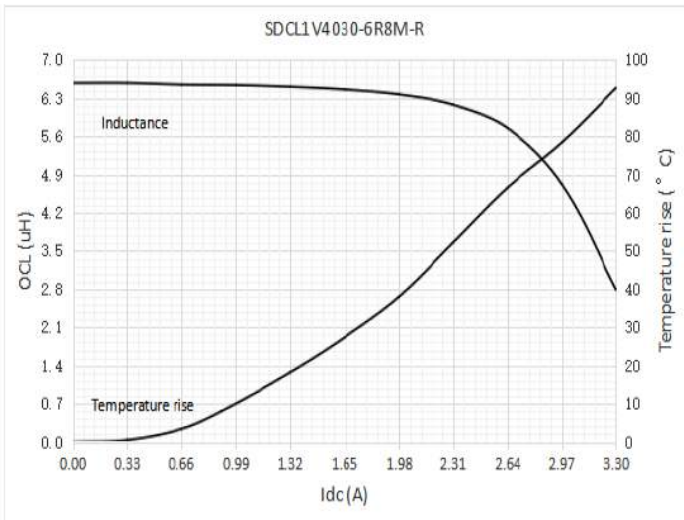

Inductance and temperature rise vs current
SDCL1V4030

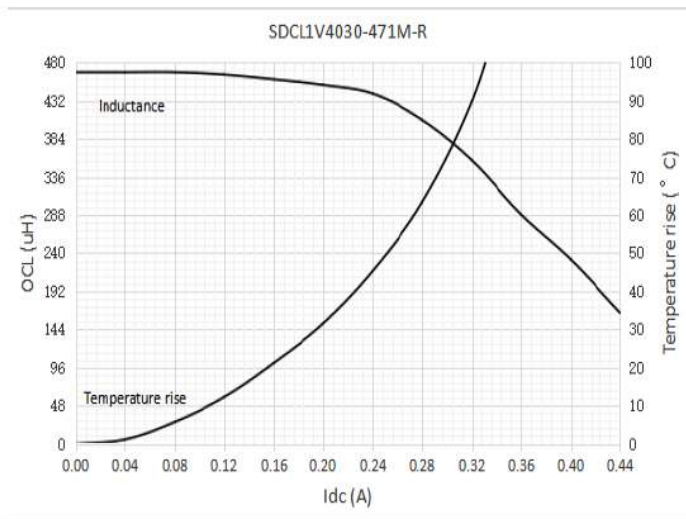
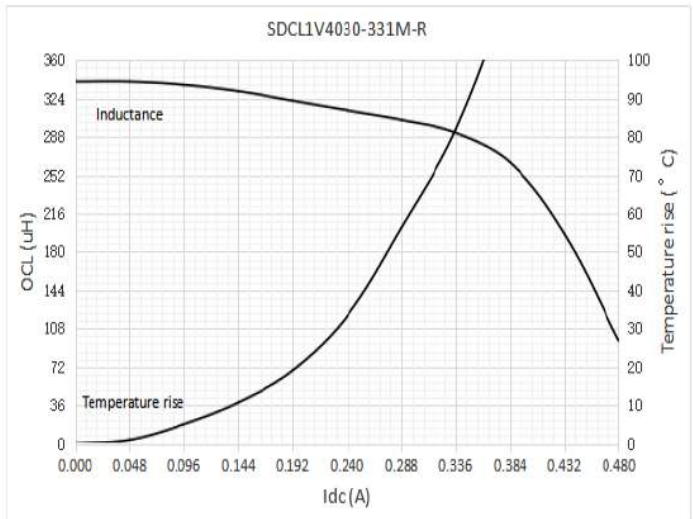
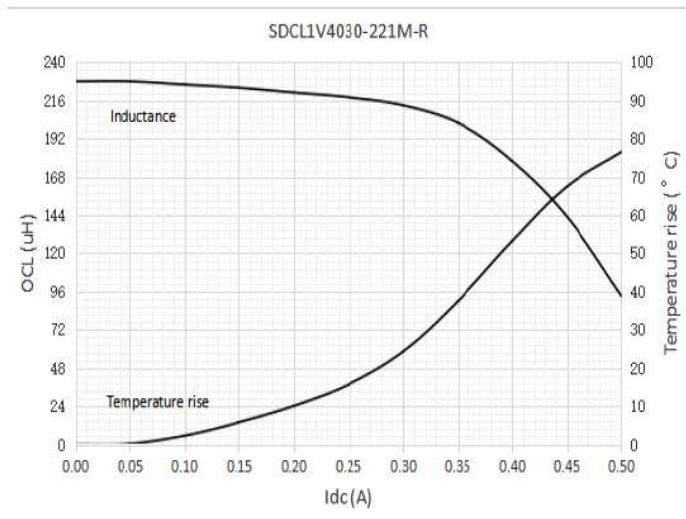
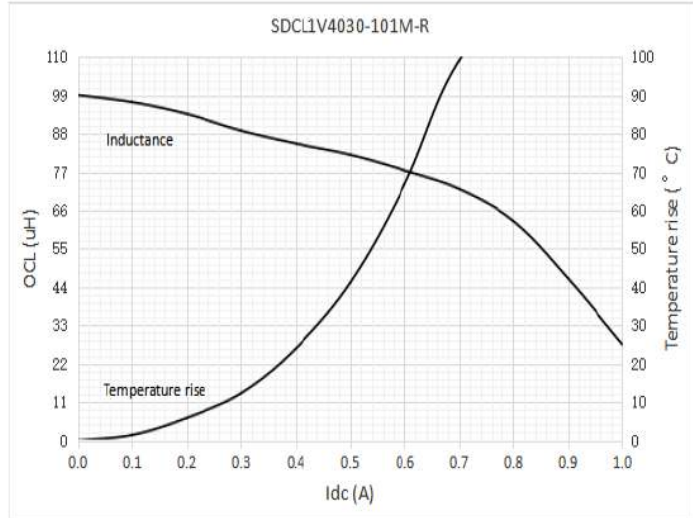
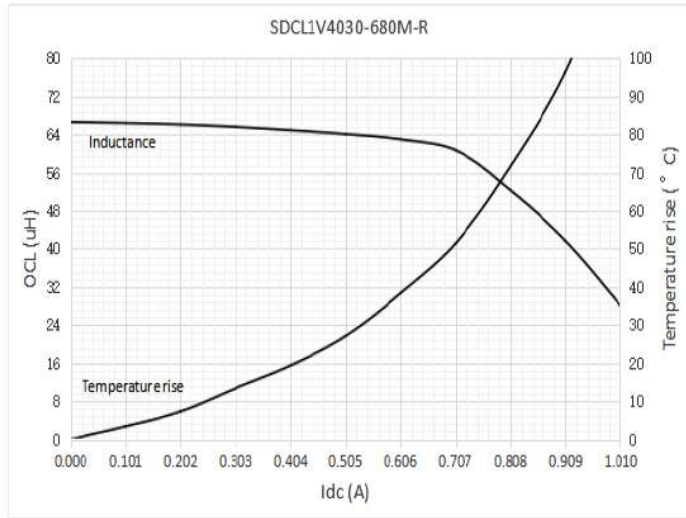

Solder reflow profile

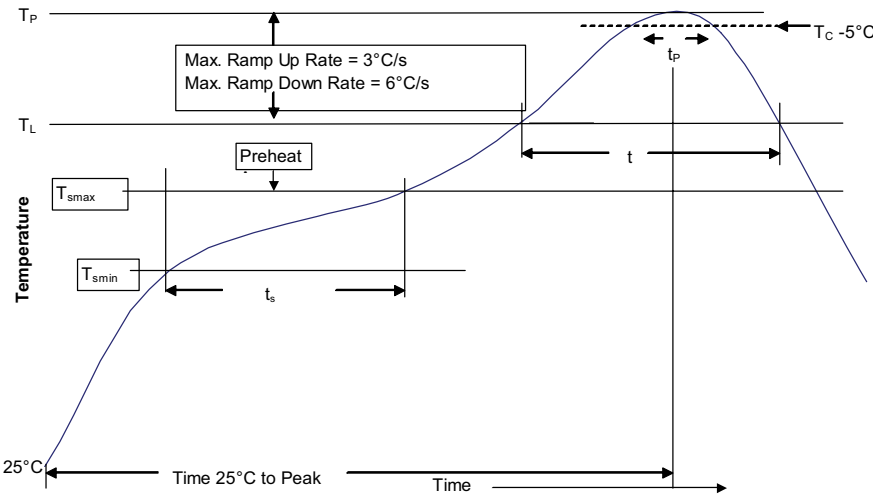

Table 1 - Standard SnPb solder (T_C)

Package thickness	Volume mm ³ <350	Volume mm ³ ≥350
<2.5 mm	235 °C	220 °C
≥2.5 mm	220 °C	220 °C

Table 2 - Lead (Pb) free solder (T_C)

Package thickness	Volume mm ³ <350	Volume mm ³ 350 - 2000	Volume mm ³ >2000
<1.6 mm	260 °C	260 °C	260 °C
1.6 – 2.5 mm	260 °C	250 °C	245 °C
>2.5 mm	250 °C	245 °C	245 °C

Reference J-STD-020

Profile feature	Standard SnPb solder	Lead (Pb) free solder
Preheat and soak		
• Temperature min. (T_{smin})	100 °C	150 °C
• Temperature max. (T_{smax})	150 °C	200 °C
• Time (T_{smin} to T_{smax}) (t_s)	60-120 seconds	60-120 seconds
Ramp up rate T_L to T_p	3 °C/ second max.	3 °C/ second max.
Liquidous temperature (T_L)	183 °C	217 °C
Time (t_L) maintained above T_L	60-150 seconds	60-150 seconds
Peak package body temperature (T_p)*	Table 1	Table 2
Time (t_p)* within 5 °C of the specified classification temperature (T_C)	20 seconds*	30 seconds*
Ramp-down rate (T_p to T_L)	6 °C/ second max.	6 °C/ second max.
Time 25 °C to peak temperature	6 minutes max.	8 minutes max.

* Tolerance for peak profile temperature (T_p) is defined as a supplier minimum and a user maximum.

Life Support Policy: Eaton does not authorize the use of any of its products for use in life support devices or systems without the express written approval of an officer of the Company. Life support systems are devices which support or sustain life, and whose failure to perform, when properly used in accordance with instructions for use provided in the labeling, can be reasonably expected to result in significant injury to the user.

Eaton reserves the right, without notice, to change design or construction of any products and to discontinue or limit distribution of any products. Eaton also reserves the right to change or update, without notice, any technical information contained in this bulletin.

Eaton
Electronics Division
1000 Eaton Boulevard
Cleveland, OH 44122
United States
Eaton.com/electronics

© 2021 Eaton
All Rights Reserved
Printed in USA
Publication No. ELX1032 BU-ELX21031
April 2021

Eaton is a registered trademark.
All other trademarks are property of their respective owners.

Follow us on social media to get the latest product and support information.

