

THIS DRAWING IS UNPUBLISHED. RELEASED FOR PUBLICATION
 © COPYRIGHT BY TYCO ELECTRONICS CORPORATION. ALL RIGHTS RESERVED.

LOC	DIST	REVISIONS					
		P	LTR	DESCRIPTION	DATE	DWN	APVD
G	01						
		01		REV PER ECR 07-016664	23JUL07	JR	TM

- 1 STAMP AMP 22-16
LOCATE IN AREA APPROX AS SHOWN
- 2 COPPER PER ASTM B-152, ANNEALED
- 3 0.00254 [.000100] MIN THK TIN PLATE
PER ASTM B-545

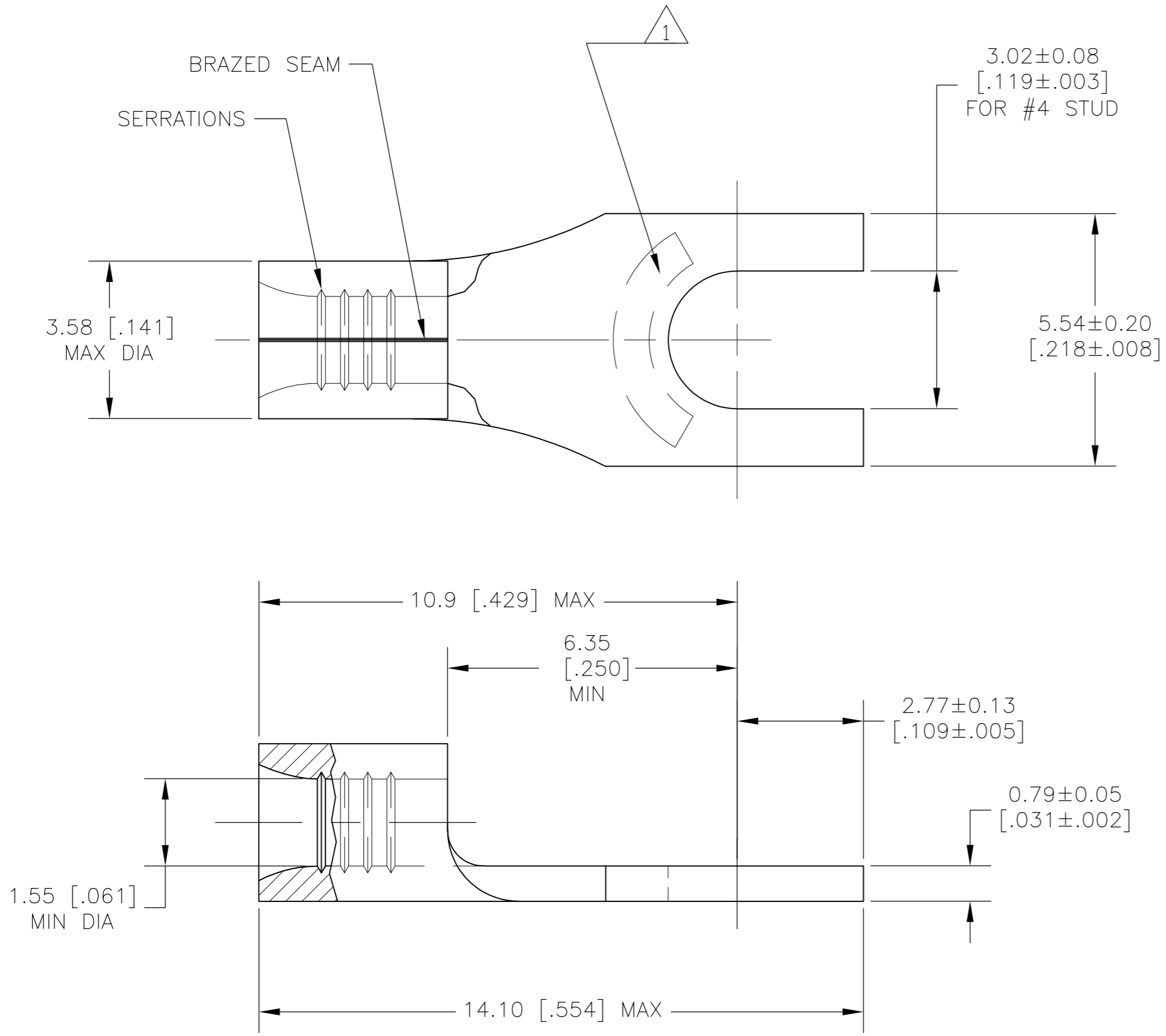

AMP WIRE RANGE	Listed FILE E13288
22-16 AWG SOLID OR STRANDED	22-16 AWG SOLID OR STRANDED

-	LOOSE PIECE	130524
QTY	PACKAGE TYPE	PART NUMBER

AMP INCORPORATED CUSTOMER SERVICE SYSTEMS		MAX RECOMMENDED OPERATING TEMPERATURE: 170°C	THIS DRAWING IS A CONTROLLED DOCUMENT.		DWN JR RUTH 23JUL07	Tyco Electronics Corporation Harrisburg, PA 17105-3608
FOR ADDITIONAL PRODUCT INFORMATION OR COPIES OF DRAWINGS AND TECHNICAL DOCUMENTS	PRODUCT INFORMATION CENTER 1-800-522-6752	VOLTAGE RATING: N/A	DIMENSIONS: INCHES	TOLERANCES UNLESS OTHERWISE SPECIFIED: 0 PLC ± - 1 PLC ± 0.2 [.008] 2 PLC ± - 3 PLC ± - 4 PLC ± - ANGLES ± -	CHK T MICHIELUTTI 23JUL07	
FOR APPLICATION	TOOLING ASSISTANCE CENTER 1-800-722-1111	CIRCULAR MIL AREA: 0.26-1.65mm² [509-3260] SOLID OR STRANDED		MATERIAL	APVD T MICHIELUTTI 23JUL07	PRODUCT SPEC
TOOLING INFORMATION	1-800-526-5142	THIS DRAWING IS A CONTROLLED DOCUMENT FOR AMP INCORPORATED. IT IS SUBJECT TO CHANGE AND THE CONTROLLING ENGINEERING ORGANIZATION SHOULD BE CONTACTED FOR THE LATEST REVISION.		FINISH	APPLICATION SPEC	TERMINAL BODY, SPADE, WIRE SIZE: 22-16
FOR ORDER ENTRY	1-800-526-5142				WEIGHT	SIZE CAGE CODE DRAWING NO RESTRICTED TO
						A2 00779 C=130524
						SCALE 10:1 SHEET 1 OF 1 REV 01

130524