

LOC		DIST		REVISIONS			
P	LTN	DESCRIPTION	DATE	OWN	APPD		
F		REDRAWN PER ECO-12-008266	27AUG2012	CJV	CWR		
G		REVISED PER ECO-13-006091	30APR2013	CJV	CWR		
H		REVISED PER ECO-13-007439	09JUL2013	CJV	CWR		

COVER IN PRE-CLAMPED POSITION

COVER IN CLAMPED POSITION WITH OPTIONAL STRAIN RELIEF ATTACHED

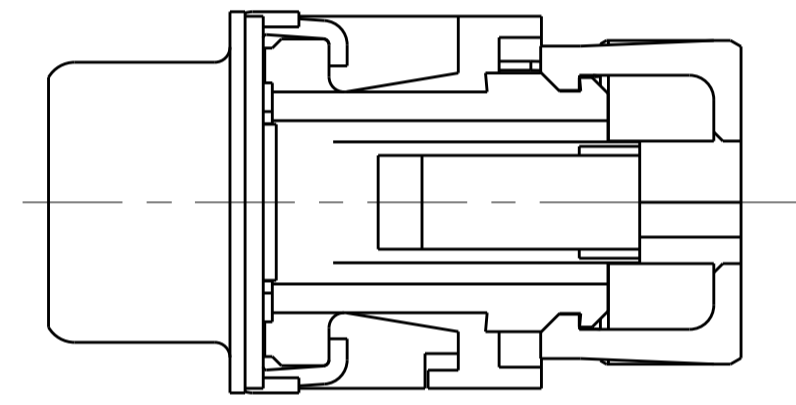
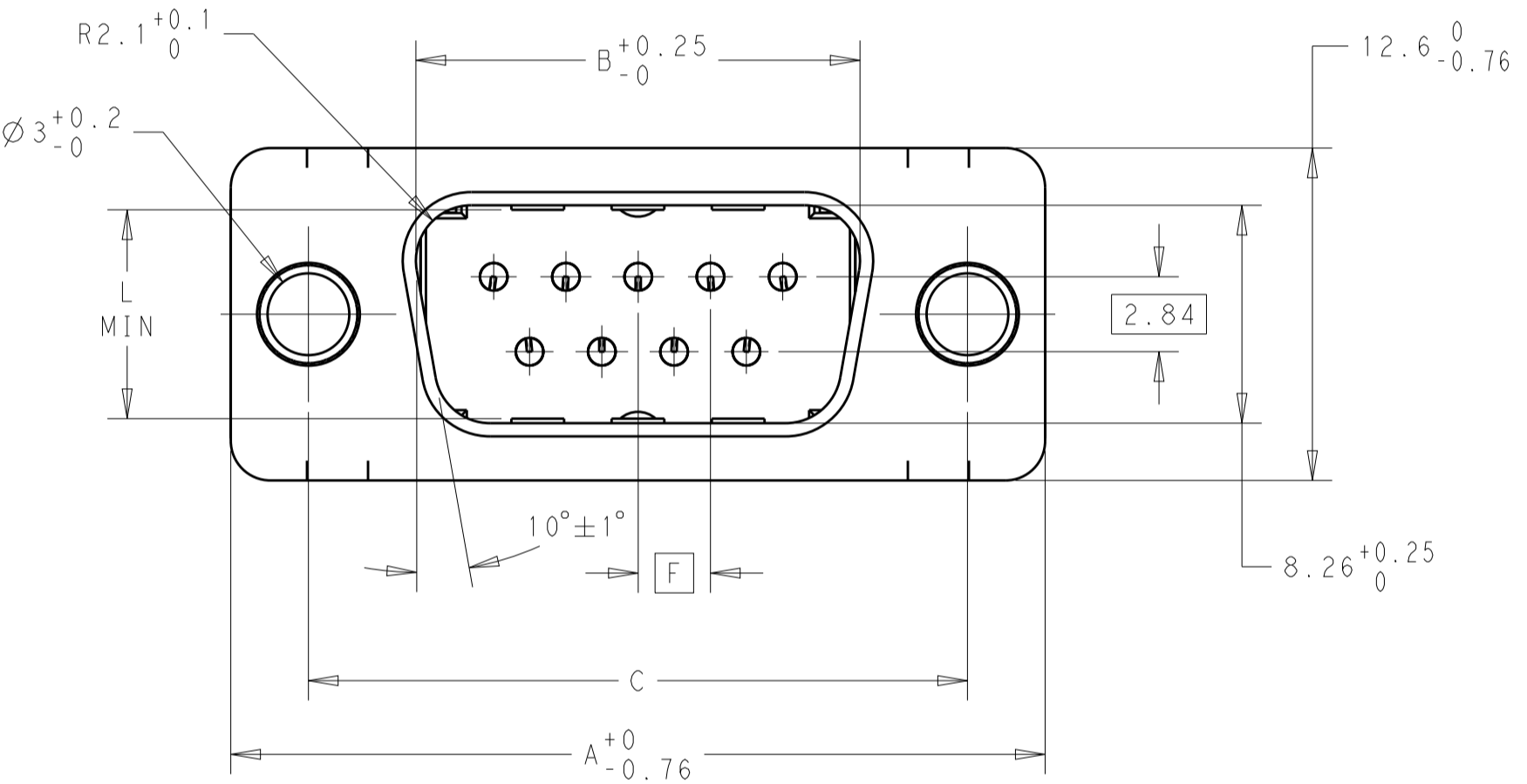
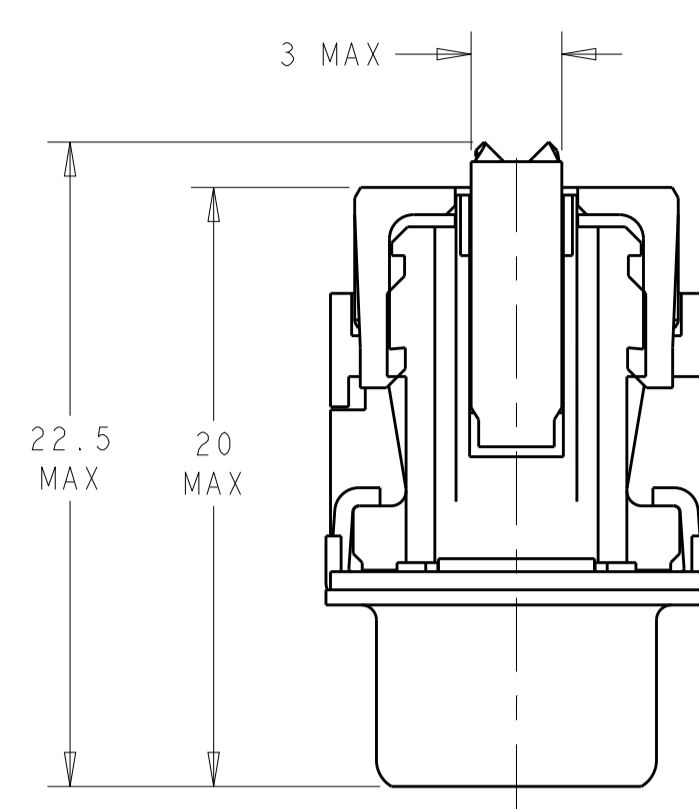
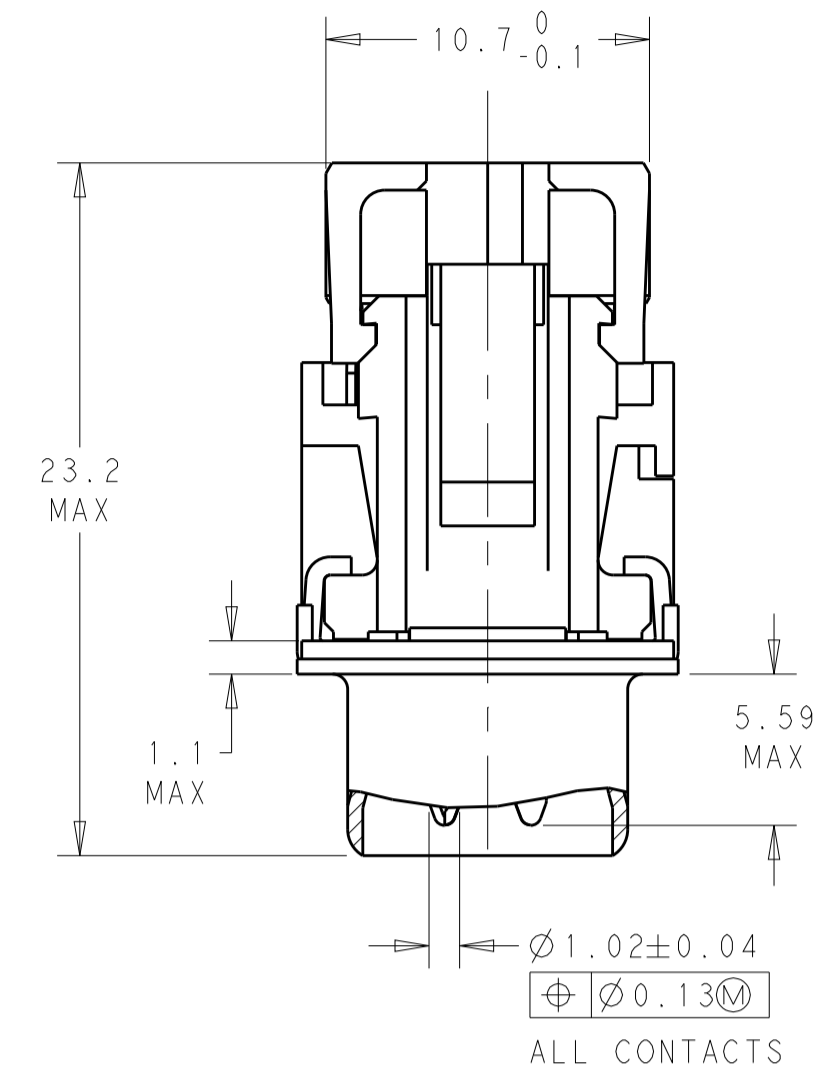
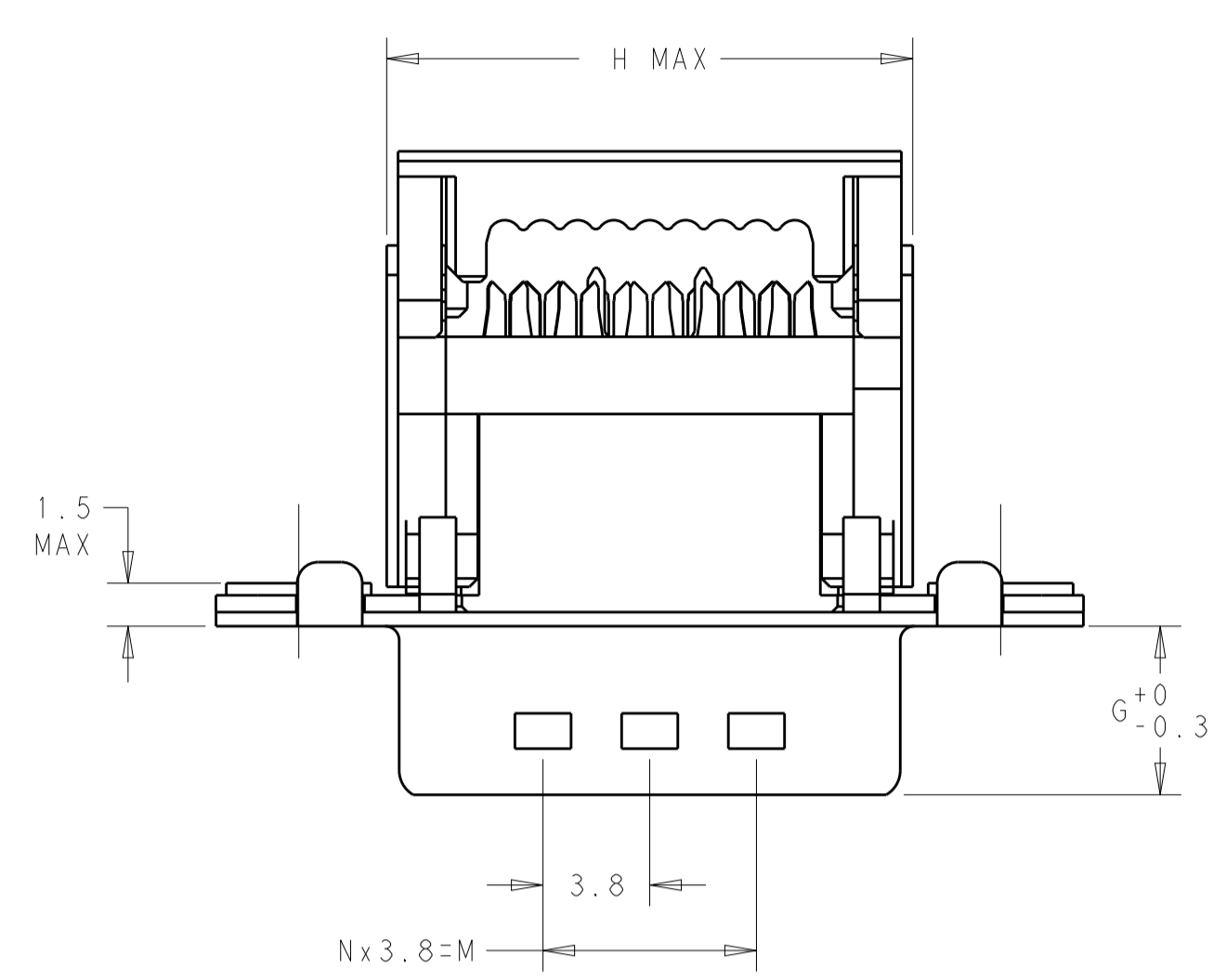

- CABLES TO BE USED:  
ALL COMMERCIALY AVAILABLE RIBBON CABLE WITH PVC INSULATION AND TIN OR SILVER PLATED COPPER WIRES. SEE WIRE INFORMATION IN TABLE BELOW.
- 9 POSITION VERSION SHOWN.
- USE ONLY WITH STRAIN RELIEF CLAMP.
- OPTIONAL STRAIN RELIEF CLAMPS:  
9 POSITION = 4-1393560-3 (V42254-A4000-D9)  
15 POSITION = 4-1393560-5 (V42254-A4000-D15)  
25 POSITION = 4-1393560-6 (V42254-A4000-D25)  
37 POSITION = 4-1393560-7 (V42254-A4000-D37)
- CONTACTS ARE STAMPED AND FORMED.
- PACKAGED IN BLISTER PACKS.
- PACKAGED ON REELS.
- PLATING DETAILS: ALL MEET PERFORMANCE LEVEL 2 PER DIN 41652 P.2 AND P.4.  
UNDERPLATE: NICKEL OVER ENTIRE CONTACT  
CONTACT MATING SURFACE ALTERNATE 1: GOLD  
CONTACT MATING SURFACE ALTERNATE 2: GOLD FLASH OVER PALLADIUM-NICKEL  
IDC WIRE TERMINATION END: MATTE TIN  
SHELL PLATING: BRIGHT TIN OVER NICKEL
- PRESS-ON COVER PROVIDED SEPARATELY (NOT PRE-ASSEMBLED)
- FLANGES WITH M3 (BLACK) OR 4-40 (BLUE)  
SELF-LOCKING NUTS  
TORQUE RETENTION ≥ 70 N-cm
- ALL PARTS MARKED WITH TE LOGO.

WIRE INFORMATION

OVERALL CONDUCTOR CROSS-SECTIONAL AREA IN mm <sup>2</sup>	AWG RANGE	OVERALL CONDUCTOR DIAMETER IN mm	NO. OF SINGLE STRANDED WIRES	CONDUCTOR	PVC INSULATING SLEEVE DIA
---	30	0.25	1	SOLID	1.0/1.1
---	28	0.32	1	SOLID	0.8/1.1
0.09	28	---	7	STRANDED	0.8/1.1
0.14	26	---	7	STRANDED	0.8/1.1

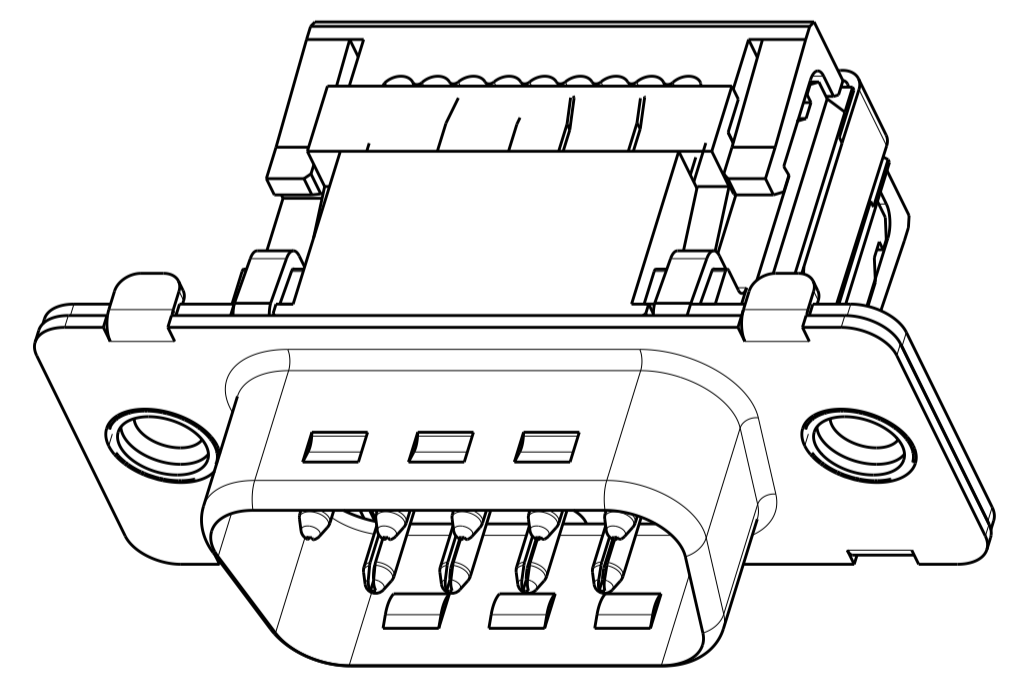
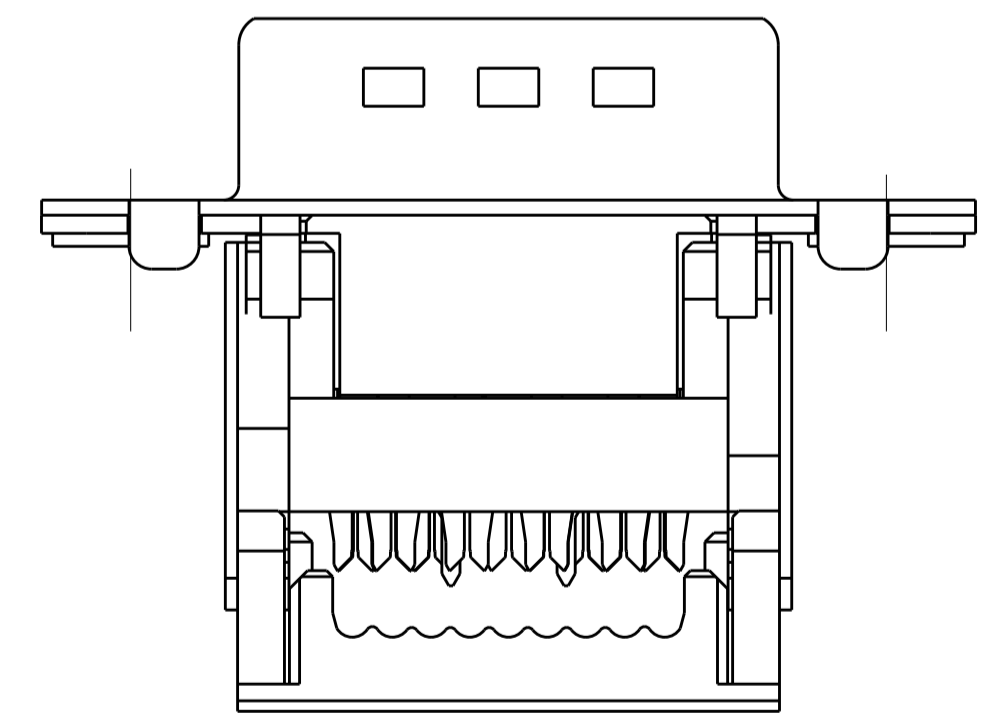

FLANGES WITH HOLES

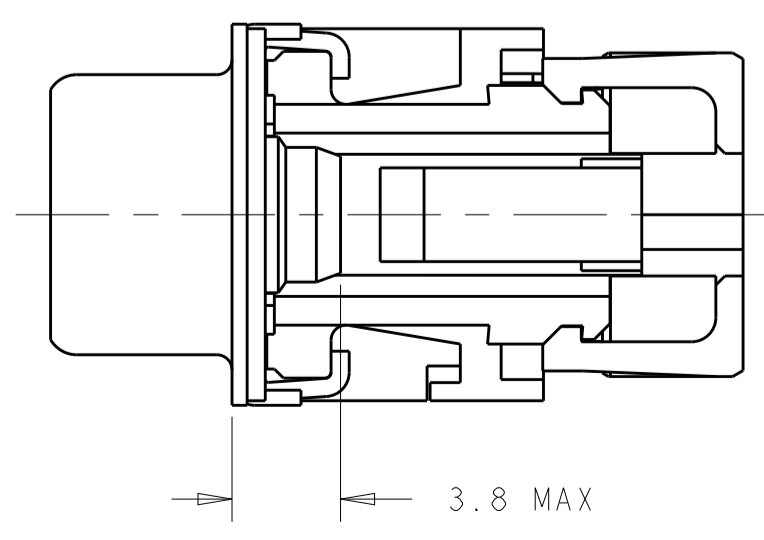
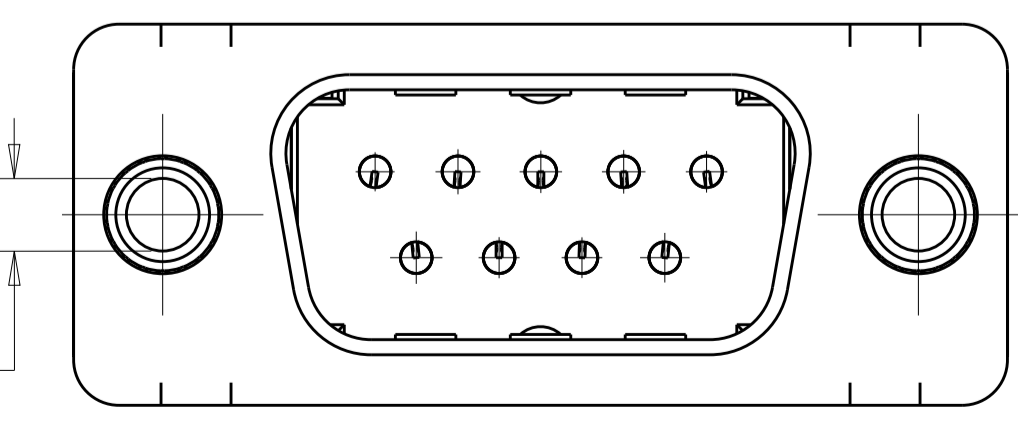

SELF-LOCKING NUT VERSION

Not Included	6/9	3.0 DIAMETER HOLE	53.42	38.84	47.04 ±0.13	2.76	5.99	40.78	7.65	26.60	7	25	V42254-A6235-C225	1-1393487-8	
Included		3.0 DIAMETER HOLE	69.70	55.30	63.50 ±0.13	2.76	5.99	57.44	7.65	41.80	11	37	V42254-A5235-W235	6-1393486-2	
Included		3.0 DIAMETER HOLE	53.42	38.84	47.04 ±0.13	2.76	5.99	40.78	7.65	26.60	7	25	V42254-A5235-W234	6-1393486-1	
Included		3.0 DIAMETER HOLE	31.19	16.79	25.00 +0.12/-0.13	2.74	6.12	18.73	7.72	7.60	2	9	V42254-A5235-W232	5-1393486-9	
Not Included		3.0 DIAMETER HOLE	69.70	55.30	63.50 ±0.13	2.76	5.99	57.44	7.65	41.80	11	37	V42254-A5235-C237	4-1393486-6	
Not Included		3.0 DIAMETER HOLE	53.42	38.84	47.04 ±0.13	2.76	5.99	40.78	7.65	26.60	7	25	V42254-A5235-C225	4-1393486-4	
Not Included	6	3.0 DIAMETER HOLE	39.52	25.12	33.30 +0.15/-0.1	2.74	6.12	27.26	7.69	15.20	4	15	V42254-A5235-C215	4-1393486-3	
Not Included		3.0 DIAMETER HOLE	31.19	16.79	25.00 +0.12/-0.13	2.74	6.12	18.73	7.72	7.60	2	9	V42254-A5235-C209	4-1393486-2	
OBSOLETE		M3 SELF-LOCKING NUTS	31.19	16.79	25.00 +0.12/-0.13	2.74	6.12	18.73	7.72	7.60	2	9	V42254-A5234-C209	1-1393486-4	
Not Included		4-40 SELF-LOCKING NUTS	53.42	38.84	47.04 ±0.13	2.76	5.99	40.78	7.65	26.60	7	25	V42254-A5232-C225	9-1393485-3	
Not Included		4-40 SELF-LOCKING NUTS	39.52	25.12	33.30 +0.15/-0.1	2.74	6.12	27.26	7.69	15.20	4	15	V42254-A5232-C215	9-1393485-2	
Not Included		4-40 SELF-LOCKING NUTS	31.19	16.79	25.00 +0.12/-0.13	2.74	6.12	18.73	7.72	7.60	2	9	V42254-A5232-C209	9-1393485-1	
OBSOLETE		4-40 SELF-LOCKING NUTS	39.52	25.12	33.30 +0.15/-0.1	2.74	6.12	27.26	7.69	15.20	4	15	V42254-A4232-C215	6-1393485-8	
STRAIN RELIEF	PKG	FLANGE OPTION	A	B	C	F	G	H	L	M	N		NO OF POSITIONS	SIEMENS PART NUMBER	TE CONNECTIVITY PART NUMBER

THIS DRAWING IS A CONTROLLED DOCUMENT. DIMENSIONING AND TOLERANCING PER ASME Y14.5M-2009. TOLERANCES UNLESS OTHERWISE SPECIFIED:

DIMENSIONS:	TOLERANCES UNLESS OTHERWISE SPECIFIED:
mm	0 PLC ±
	1 PLC ±
	2 PLC ±
	3 PLC ±
	4 PLC ±
ANGLES	±0.1°
MATERIAL	FINISH

OWN: RAGHAVENDRA 03MAR2012  
 CHK: CARL ROHDE 03MAR2012  
 APVD: CARL ROHDE 03MAR2012  
 NAME: D-SUB IDC PLUGS WITH GROUNDING FINGERS  
 SIZE: A100779 CAGE CODE: 9-1393485-1 DRAWING NO: 9-1393485-1  
 CUSTOMER DRAWING SCALE: 4:1 SHEET: 1 OF 1 REV: H