

Tiny Package, High Performance, Diode Embedded White LED Driver

General Description

The RT9285C is a high frequency asynchronous boost converter with internal diode, which can support 2 to 5 White LEDs for backlighting and OLED power supply. The Internal soft start function can reduce the inrush current. The device operates with 1MHz fixed switching frequency to allow small external components and to simplify possible EMI problems. The device comes with 20V over voltage protection to allow inexpensive and small-output capacitors with lower voltage rating. The LED current is initially set with the external sense resistor R_{SET} , and the feedback voltage is 250mV. Tiny package type TSOT-23-6, XDFN-8L 2x2 and WDFN-8L 2x2 packages provide the best solution for PCB space saving and total BOM cost.

Ordering Information

RT9285C□□

- Package Type
 - QW : WDFN-8L 2x2 (W-Type)
 - QX : XDFN-8L 2x2 (X-Type)
 - J6 : TSOT-23-6
- Lead Plating System
 - P : Pb Free
 - G : Green (Halogen Free and Pb Free)
 - Z : ECO (Ecological Element with Halogen Free and Pb free)

Note :

Richtek products are :

- ▶ RoHS compliant and compatible with the current requirements of IPC/JEDEC J-STD-020.
- ▶ Suitable for use in SnPb or Pb-free soldering processes.

Marking Information

For marking information, contact our sales representative directly or through a Richtek distributor located in your area.

Features

- V_{IN} Operating Range : 2.7V to 5.5V
- Up to 85% Efficiency
- 22V Internal Power NMOS
- 1MHz Switching Frequency
- Built-in Diode
- Digital Dimming with Zero-Inrush
- Input UVLO Protection
- Output Over Voltage Protection
- Internal Soft Start and Compensation
- TSOT-23-6, 8-Lead XDFN and WDFN Package
- RoHS Compliant and 100% Lead (Pb)-Free

Applications

- Cellular Phones
- Digital Cameras
- PDAs and Smart Phones
- Portable Instruments
- MP3 Player
- OLED Power

Pin Configurations

(TOP VIEW)

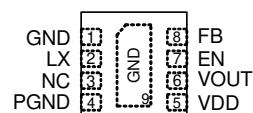

XDFN/WDFN-8L 2x2

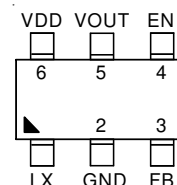

TSOT-23-6

Typical Application Circuit

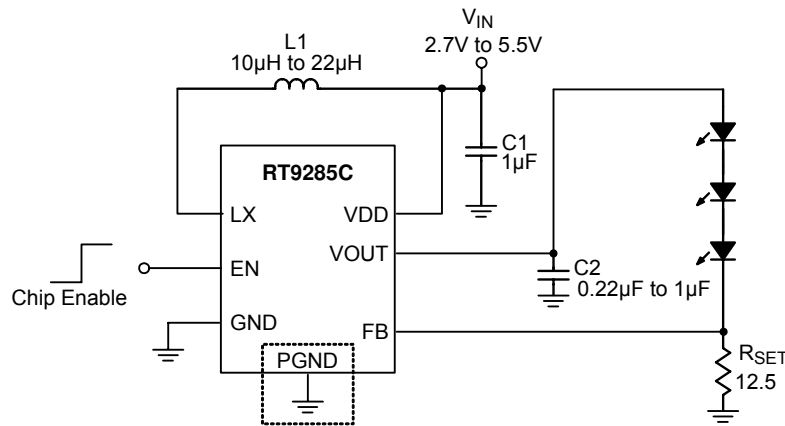

PGND pin for XDFN/WDFN-8L Packages

Function Pin Description

Pin No.		Pin Name	Pin Function
XDFN/WDFN-8L	TSOT-23-6		
1, 9 (Exposed Pad)	2	GND	Ground Pin. The exposed pad must be soldered to a large PCB and connected to GND for maximum power dissipation.
2	1	LX	LX Pin. Connect this Pin to an inductor. Minimize the track area to reduce EMI.
3	--	NC	No Internal Connection.
4	--	PGND	Power Ground Pin.
5	6	VDD	Supply Input Voltage Pin. Bypass 1µF capacitor to GND to reduce the input ripple.
6	5	VOUT	Output Voltage pin. The pin internally connects to OVP diode to limit output voltage while LEDs are disconnected.
7	4	EN	Chip Enable (Active High). Note that this pin has an internal pull-down resistance around 300kΩ.
8	3	FB	Feedback Pin. Series connecting a resistor between WLED and ground as a current sense. Sense the current feedback voltage to set the current rating.

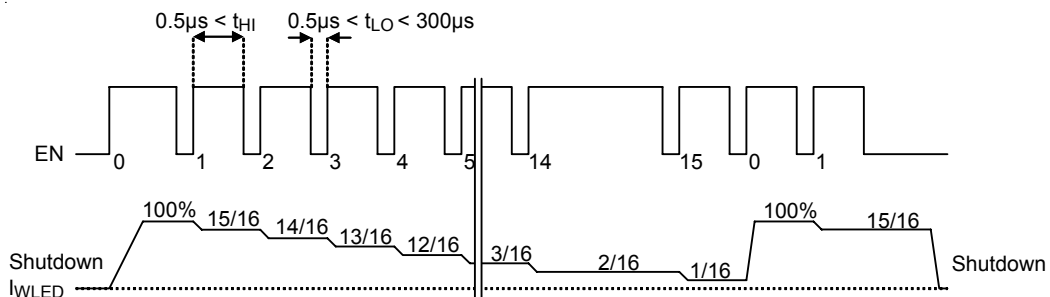
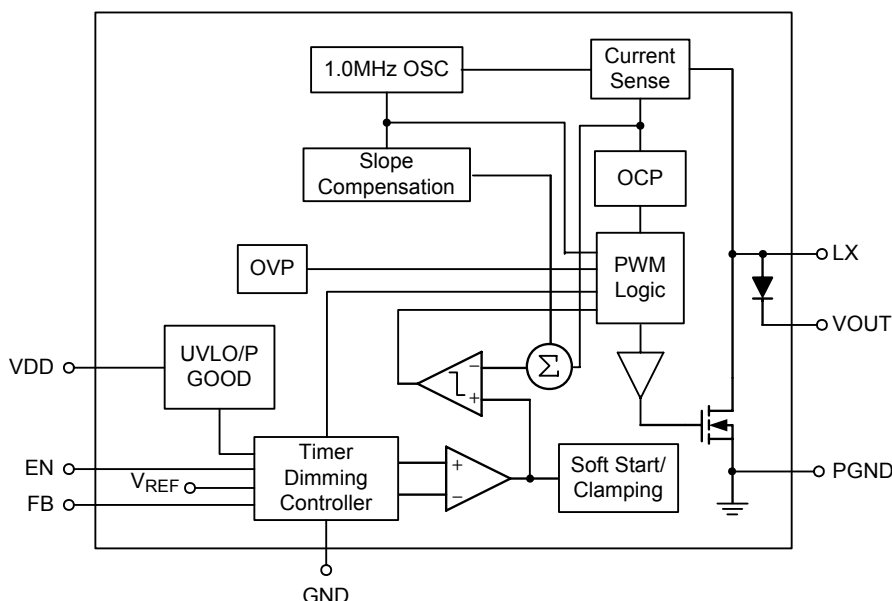

Figure 1. Operation of Digital Pulse Dimming Control

Function Block Diagram



Operation

Soft-Start

The Soft-Start function is made by clamping the output voltage of error amplifier with another voltage source that is increased slowly from zero to near V_{IN} in the Soft-Start period. Therefore, the duty cycle of the PWM will be increased from zero to maximum in this period. The soft-start time is decided by a timer of 1.5ms. The charging time of the inductor will be limited as the smaller duty so that the inrush current can be reduced to an acceptable value.

Over Voltage Protection

The Over Voltage Protection is detected by a junction breakdown detecting circuit. Once V_{OUT} goes over the detecting voltage, LX pin stops switching and the power NMOS is turned off. Then, the V_{OUT} is clamped to be near V_{OVP} .

LED Current Setting

The RT9285C regulates the LED current by setting the current sense resistor (R_{SET}) connecting to feedback and ground. The internal feedback reference voltage is 0.25V. The LED current can be set from following equation easily.

$$I_{LED} \text{ (mA)} = 0.25/R_{SET}$$

In order to have an accurate LED current, precision resistors are preferred (1% is recommended). The table for R_{SET} selection is shown below.

Table 1. R_{SET} Value Selection

I_{LED} (mA)	R_{SET} (Ω)
5	49.9
10	24.9
12	21
15	16.5
20	12.4

Digital Pulse Dimming Control

RT9285C implements the pulse dimming method being used to control the brightness of white LEDs. There are 16 steps to set the current of white LEDs. The maximum LED current is up to 20mA that is sufficient for most application in backlight. The detail operation of brightness dimming is showed in the Figure 1.

Current Limiting

The current flow through the inductor as charging period is detected by a current sensing circuit. As the value over the current limiting, the NMOS will be turned-off so that the inductor will be forced to leave charging stage and enter discharging stage. Therefore, the inductor current will not increase over the current limiting.

Absolute Maximum Ratings (Note 1)

• Supply Voltage, V_{IN}	-----	-0.3 to 6V
• LX Input Voltage	-----	-0.3V to 22V
• Output Voltage	-----	-0.3V to 21V
• The other pins	-----	-0.3V to 6V
• Power Dissipation, $P_D @ T_A = 25^\circ\text{C}$		
TSOT23-6	-----	0.392W
XDFN/WDFN-8L 2x2	-----	0.606W
• Package Thermal Resistance (Note 2)		
TSOT23-6, θ_{JA}	-----	255°C/W
XDFN/WDFN-8L 2x2, θ_{JA}	-----	165°C/W
XDFN/WDFN-8L 2x2, θ_{JC}	-----	20°C/W
• Junction Temperature	-----	150°C
• Lead Temperature (Soldering, 10 sec.)	-----	260°C
• Storage Temperature Range	-----	-65°C to 150°C

Recommended Operating Conditions (Note 3)

• Junction Temperature Range	-----	-40°C to 125°C
• Ambient Temperature Range	-----	-40°C to 85°C

Electrical Characteristics

($V_{IN} = 3.7\text{V}$, FREQ left floating, $T_A = 25^\circ\text{C}$, Unless Otherwise specification)

Parameter	Symbol	Test Conditions	Min	Typ	Max	Unit
System Supply Input						
Operation voltage Range	V_{IN}		2.7	--	5.5	V
Under Voltage Lock Out	V_{UVLO}		1.7	2	2.3	V
Quiescent Current	I_Q	FB = 1.5V, No switch	--	300	450	μA
Supply Current	I_{IN}	FB = 0V, Switch	--	--	2	mA
Shut Down Current	I_{SHDN}	$V_{EN} < 0.4\text{V}$	--	2	5	μA
Output						
Line Regulation		$V_{IN} = 3\text{V to } 4.3\text{V}$	--	--	3	%
Oscillator						
Operation Frequency	f_{OSC}		--	1	--	MHz
Maximum Duty Cycle			85	90	--	%
Reference Voltage						
Feedback Reference Voltage	V_{REF}		0.237	0.25	0.263	V
Diode						
Forward Voltage	V_{FW}	$I_{FW} = 100\text{mA}$	--	0.9	--	V
MOSFET						
On Resistance of MOSFET	$R_{DS(ON)}$		0.5	0.75	1	Ω
Protection						
OVP Threshold	V_{OVP}		--	20	--	V
OCP			--	400	--	mA

To be continued

Parameter	Symbol	Test Conditions	Min	Typ	Max	Unit
Control Interface						
EN Threshold	Logic-Low Voltage	V _{IL}	–	--	0.4	V
	Logic-High Voltage	V _{IH}	1.4	--	--	
EN Low Time for Dimming	T _{LO}	Refer to Figure 1	0.5	--	300	μs
Delay Between Steps Time	T _{HI}	Refer to Figure 1	0.5	--	--	μs
EN Low Time for Shut Down	T _{SHDN}	Refer to Figure 1	1	--	--	ms

Note 1. Stresses listed as the above "Absolute Maximum Ratings" may cause permanent damage to the device. These are for stress ratings. Functional operation of the device at these or any other conditions beyond those indicated in the operational sections of the specifications is not implied. Exposure to absolute maximum rating conditions for extended periods may remain possibility to affect device reliability.

Note 2. θ_{JA} is measured in the natural convection at $T_A = 25^\circ\text{C}$ on a low effective thermal conductivity test board of JEDEC 51-3 thermal measurement standard.

Note 3. The device is not guaranteed to function outside its operating conditions.

Typical Operating Characteristics

OVP vs. Input Voltage

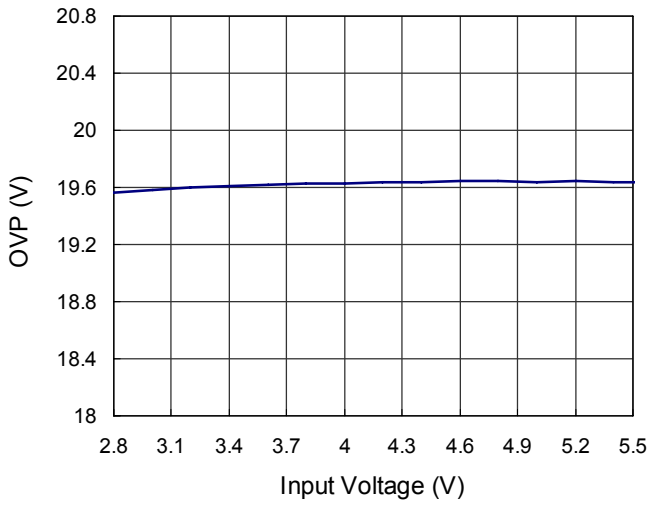

Efficiency vs. Input Voltage

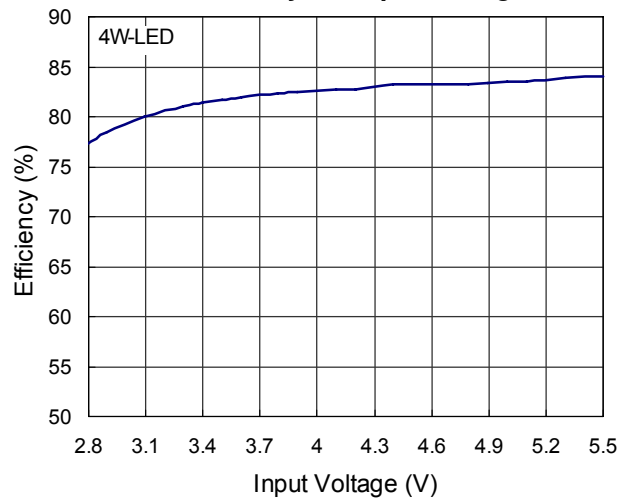

Quiescent Current vs. Input Voltage

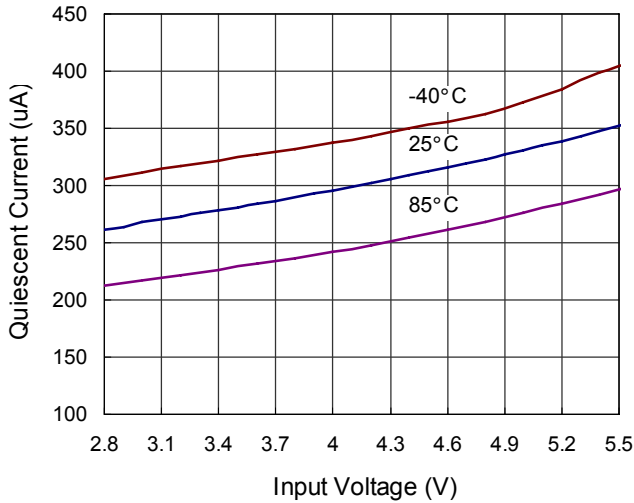

Frequency vs. Input Voltage

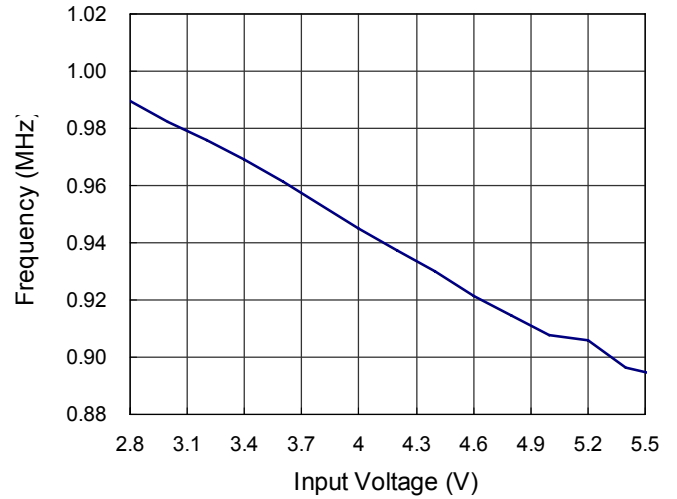

Enable Voltage vs. Input Voltage

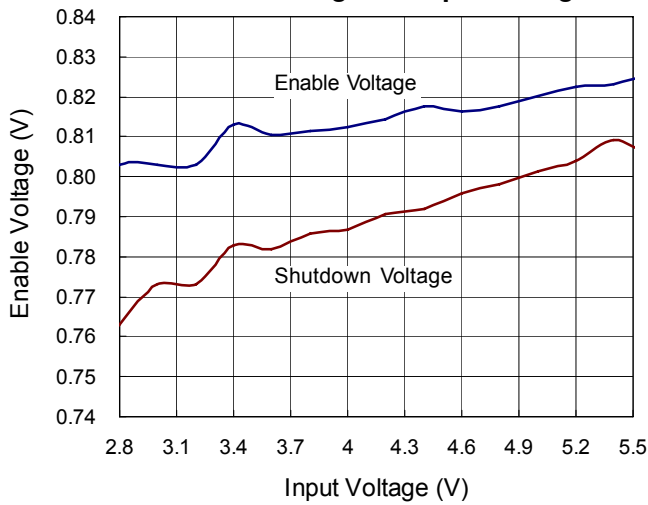

Output Voltage vs. Output Current

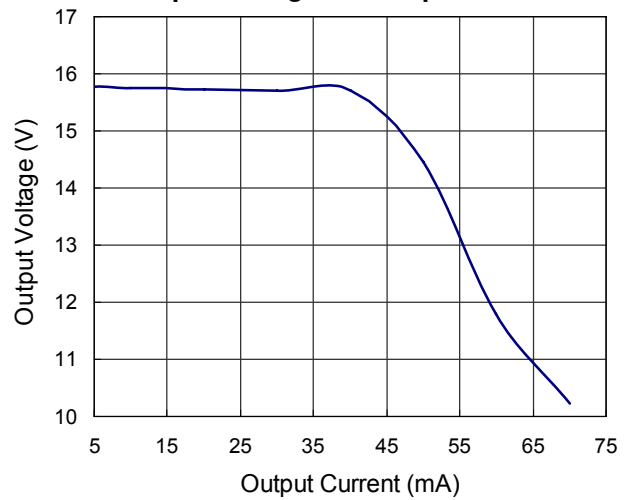

Feedback Reference Voltage vs. Input Voltage

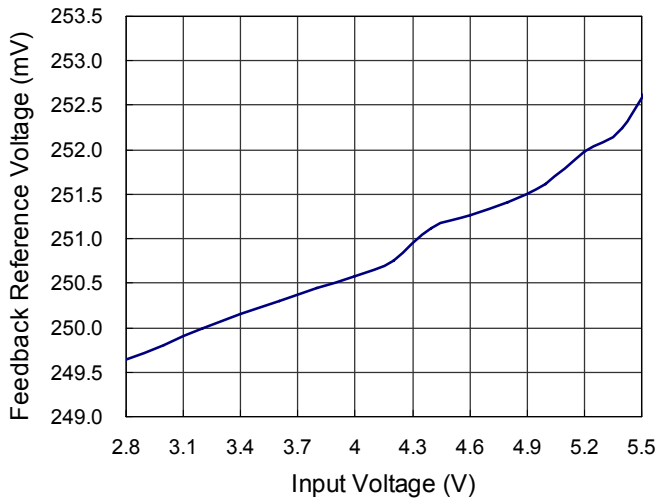

Dimming Operation @ Decrease

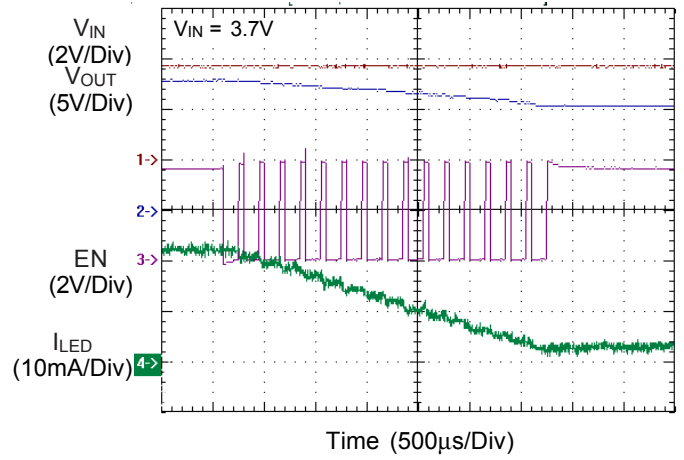

Inrush Current Response

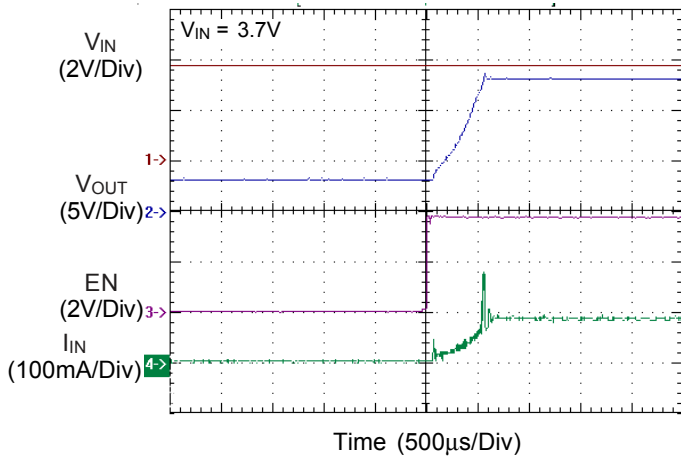

Application Information

LED Current Control

The RT9285C regulates the LED current by setting the current sense resistor (R_{SET}) connecting to feedback and ground. The RT9284A/B feedback voltage (V_{FB}) is 0.25V. The LED current (I_{LED}) can be set by a resistor R_{SET} .

$$I_{LED} = 0.25/R_{SET}$$

In order to have an accurate LED current, a precision resistor is preferred (1% is recommended).

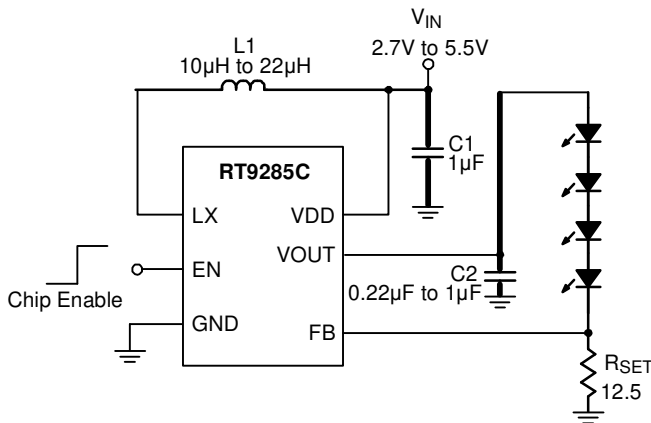

Figure 2. Application for Driving 4 Series WLEDs

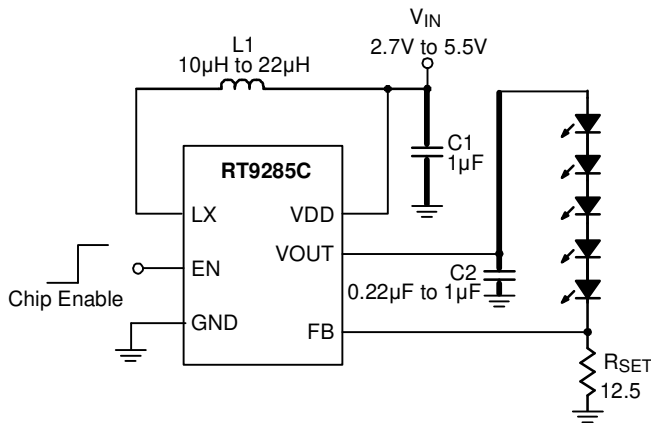

Figure 3. Application for Driving 5 Series WLEDs

Inductor Selection

The recommended value of inductor for 4 to 5WLEDs applications are 10µH to 22µH. For 3WLEDs, the recommended value of inductor is 4.7µH to 22µH. Small size and better efficiency are the major concerns for portable device, such as RT9285C used for mobile phone. The inductor should have low core loss at 1MHz and low DCR for better efficiency.

The inductor saturation current rating should be considered to cover the inductor peak current.

Capacitor Selection

Input and output ceramic capacitors of 1µF are recommended for RT9285C applications. For better voltage filtering, ceramic capacitors with low ESR are recommended. X5R and X7R types are suitable because of their wider voltage and temperature ranges.

Output Voltage Control

The output voltage of R9285C can be adjusted by the divider circuit on FB pin. Figure 5 shows a 2-level voltage control circuit for OLED application. The output voltage can be calculated by the following equations in Figure 5.

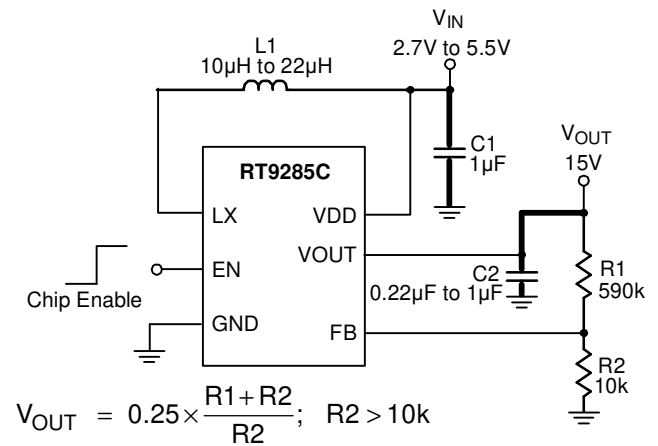

Figure 4. Application for Constant Output Voltage

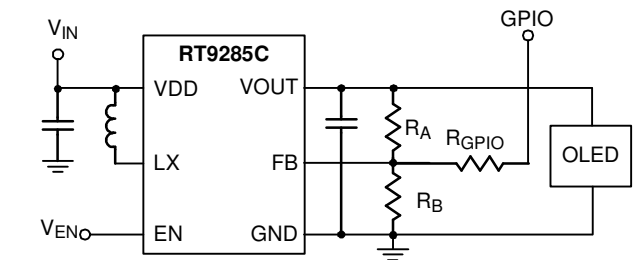

Figure 5. Application Circuit for Output Voltage Control and Related Equations

$$V_{OUT} = R_A \times \left\{ \left(\frac{FB}{R_B} \right) + \left(\frac{FB - GPIO}{R_{GPIO}} \right) \right\} + FB \quad (1)$$

As $GPIO = 0V$,

$$V_{OUT} = R_A \times \left\{ \left(\frac{0.25}{R_B} \right) + \left(\frac{0.25}{R_{GPIO}} \right) \right\} + 0.25 \quad (2)$$

As $GPIO = 2.8V$,

$$V_{OUT} = R_A \times \left\{ \left(\frac{0.25}{R_B} \right) + \left(\frac{0.25 - 2.8}{R_{GPIO}} \right) \right\} + 0.25 \quad (3)$$

As $V_{OUT} = 1.8V$, $V_{OUT} = R_A \times \{(0.25/R_B) + (0.25-1.8)/R_{GPIO}\} + 0.25$ (4)

For Efficiency Consideration :

Set $R_A = 990k\Omega$,

If 2 levels are 16V (GPIO = 0V) and 14V (GPIO = 1.8V)

Get $R_B = 16k\Omega$, $R_{GPIO} = 890k\Omega$

Table 2. Suggested Resistance for Output Voltage Control

Conditions	R_A (k Ω)	R_B (k Ω)	R_{GPIO} (k Ω)
Case A : Normal Voltage = 16V (GPIO = 0V) Dimming Voltage = 12V (GPIO = 1.8V)	1100	18	495
Case B : Normal Voltage = 16V (GPIO = 0V) Dimming Voltage = 12V (GPIO = 2.8V)	1200	19.5	840

Considering the output voltage deviation from the GPIO voltage tolerance, as GPIO voltage vibrated by $0 \pm 50mV$ and $1.8(2.8) \pm 5\%$, the output voltage could be kept within $\pm 2.5\%$.

Thermal Considerations

For continuous operation, do not exceed absolute maximum operation junction temperature. The maximum power dissipation depends on the thermal resistance of IC package, PCB layout, the rate of surroundings airflow and temperature difference between junction to ambient. The maximum power dissipation can be calculated by following formula:

$$P_{D(MAX)} = (T_{J(MAX)} - T_A) / \theta_{JA}$$

Where $T_{J(MAX)}$ is the maximum operation junction temperature $125^\circ C$, T_A is the ambient temperature and the θ_{JA} is the junction to ambient thermal resistance.

For recommended operating conditions specification of RT9285C, where $T_{J(MAX)}$ is the maximum junction

temperature of the die ($125^\circ C$) and T_A is the maximum ambient temperature. The junction to ambient thermal resistance θ_{JA} is layout dependent. For XDFN/WDFN 2x2 packages, the thermal resistance θ_{JA} is $165^\circ C/W$ on the standard JEDEC 51-3 single layer thermal test board. The maximum power dissipation at $T_A = 25^\circ C$ can be calculated by following formula:

$$P_{D(MAX)} = (125^\circ C - 25^\circ C) / (165^\circ C/W) = 0.606 W \text{ for WDFN/XDFN 2x2 packages}$$

$$P_{D(MAX)} = (125^\circ C - 25^\circ C) / (255^\circ C/W) = 0.392 W \text{ for TSOT-23-6 packages}$$

The maximum power dissipation depends on operating ambient temperature for fixed $T_{J(MAX)}$ and thermal resistance θ_{JA} . For RT9285C packages, the Figure 6 of derating curves allows the designer to see the effect of rising ambient temperature on the maximum power allowed.

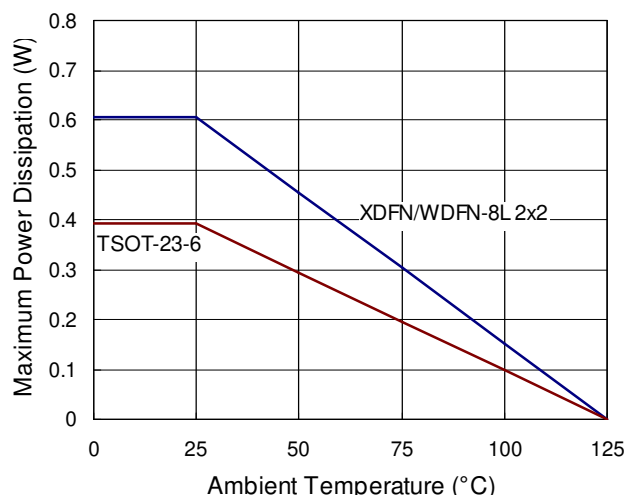

Figure 6. Derating Curves for RT9285C Packages

Layout guide

- } A full GND plane without gap break.
- } Traces in bold need to be routed first and should be kept as short as possible.
- } VDD to GND noise bypass : Short and wide connection for the $1\mu F$ MLCC capacitor between Pin 6 and Pin 2.
- } LX node copper area should be minimized for reducing EMI. (*1)
- } The input capacitor C1 should be placed as closed as possible to Pin 6. (*2)

- ▶ The output capacitor C2 should be connected directly from the Pin 5 to ground rather than across the LEDs. (*3)
- ▶ FB node copper area should be minimized and keep far away from noise sources (Pin 1, Pin 5, Pin 6). (*4)
- ▶ The Inductor is far away receiver and microphone.
- ▶ The voice trace is far away RT9285C.
- ▶ The embedded antenna is far away and different side RT9285C.
- ▶ R1 should be placed as close as RT9285C.
- ▶ The through hole of RT9285C's GND pin is recommended as large and many as possible.

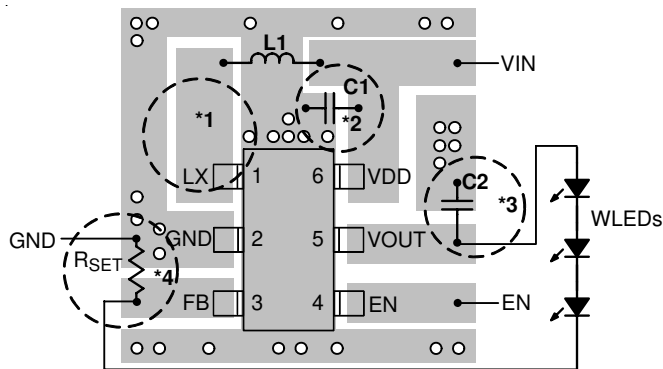

Figure 7. TOP

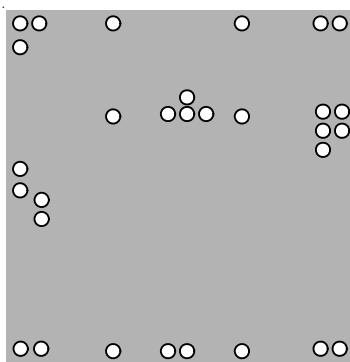
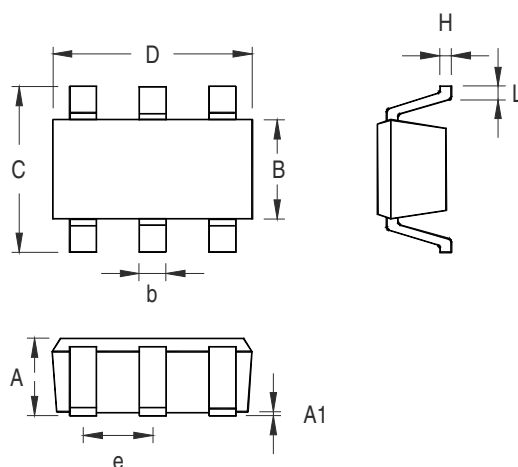

Figure 8. Bottom

Outline Dimension



Symbol	Dimensions In Millimeters		Dimensions In Inches	
	Min	Max	Min	Max
A	0.700	1.000	0.028	0.039
A1	0.000	0.100	0.000	0.004
B	1.397	1.803	0.055	0.071
b	0.300	0.559	0.012	0.022
C	2.591	3.000	0.102	0.118
D	2.692	3.099	0.106	0.122
e	0.838	1.041	0.033	0.041
H	0.080	0.254	0.003	0.010
L	0.300	0.610	0.012	0.024

TSOT-23-6 Surface Mount Package

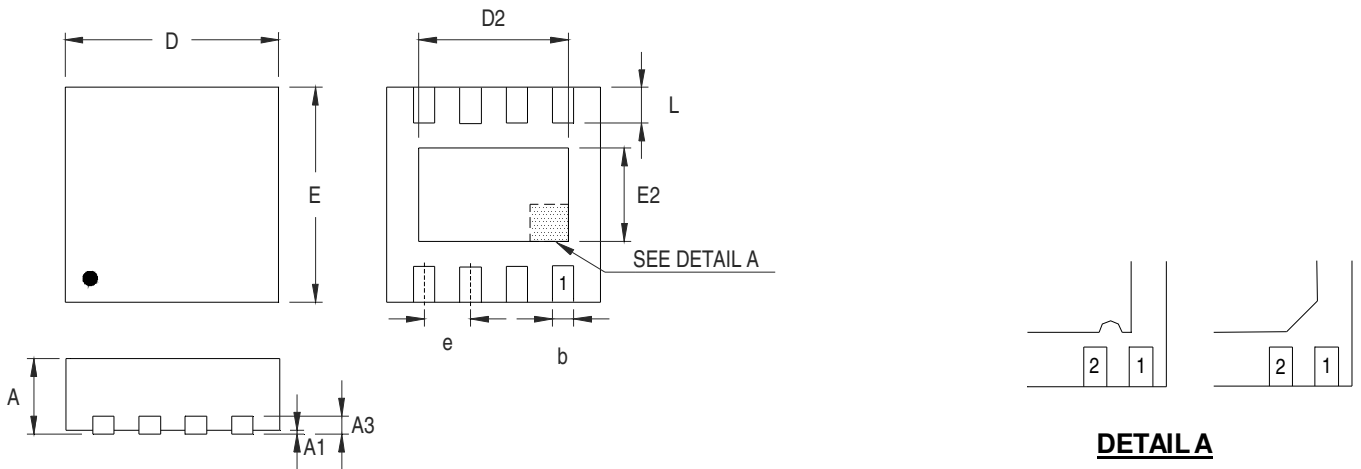

DETAIL A

Pin #1 ID and Tie Bar Mark Options

Note : The configuration of the Pin #1 identifier is optional, but must be located within the zone indicated.

Symbol	Dimensions In Millimeters		Dimensions In Inches	
	Min	Max	Min	Max
A	0.700	0.800	0.028	0.031
A1	0.000	0.050	0.000	0.002
A3	0.175	0.250	0.007	0.010
b	0.200	0.300	0.008	0.012
D	1.950	2.050	0.077	0.081
D2	1.000	1.250	0.039	0.049
E	1.950	2.050	0.077	0.081
E2	0.400	0.650	0.016	0.026
e	0.500		0.020	
L	0.300	0.400	0.012	0.016

W-Type 8L DFN 2x2 Package

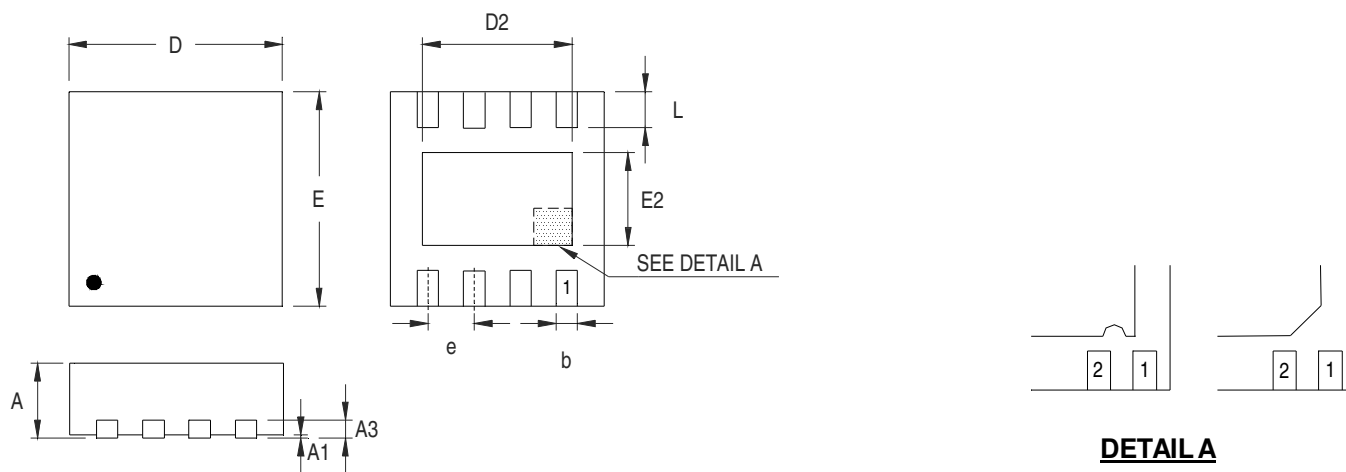

DETAIL A

Pin #1 ID and Tie Bar Mark Options

Note : The configuration of the Pin #1 identifier is optional, but must be located within the zone indicated.

Symbol	Dimensions In Millimeters		Dimensions In Inches	
	Min	Max	Min	Max
A	0.400	0.500	0.016	0.020
A1	0.000	0.050	0.000	0.002
A3	0.102	0.152	0.004	0.006
b	0.200	0.300	0.008	0.012
D	1.950	2.050	0.077	0.081
D2	1.000	1.250	0.039	0.049
E	1.950	2.050	0.077	0.081
E2	0.400	0.650	0.016	0.026
e	0.500		0.020	
L	0.300	0.400	0.012	0.016

X-Type 8L DFN 2x2 Package

Richtek Technology Corporation

Headquarter
 5F, No. 20, Taiyuen Street, Chupei City
 Hsinchu, Taiwan, R.O.C.
 Tel: (8863)5526789 Fax: (8863)5526611

Richtek Technology Corporation

Taipei Office (Marketing)
 5F, No. 95, Minchiuan Road, Hsintien City
 Taipei County, Taiwan, R.O.C.
 Tel: (8862)86672399 Fax: (8862)86672377
 Email: marketing@richtek.com

Information that is provided by Richtek Technology Corporation is believed to be accurate and reliable. Richtek reserves the right to make any change in circuit design, specification or other related things if necessary without notice at any time. No third party intellectual property infringement of the applications should be guaranteed by users when integrating Richtek products into any application. No legal responsibility for any said applications is assumed by Richtek.